

**Problem 2.1** In Active Example 2.1, suppose that the vectors  $\mathbf{U}$  and  $\mathbf{V}$  are reoriented as shown. The vector  $\mathbf{V}$  is vertical. The magnitudes are  $|\mathbf{U}| = 8$  and  $|\mathbf{V}| = 3$ . Graphically determine the magnitude of the vector  $\mathbf{U} + 2\mathbf{V}$ .

**Solution:** Draw the vectors accurately and measure the resultant.

$$R = |\mathbf{U} + 2\mathbf{V}| = 5.7 \quad \boxed{R = 5.7}$$

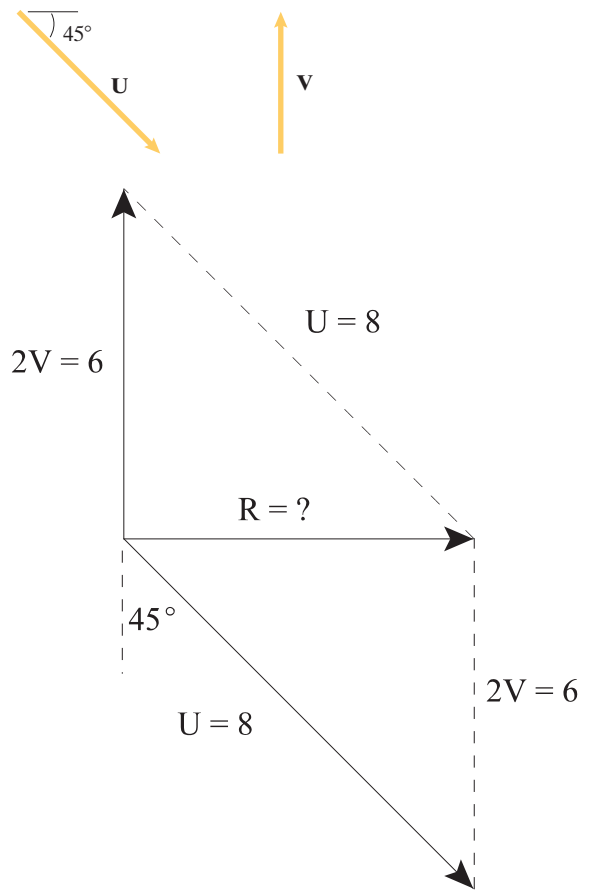

**Problem 2.2** Suppose that the pylon in Example 2.2 is moved closer to the stadium so that the angle between the forces  $\mathbf{F}_{AB}$  and  $\mathbf{F}_{AC}$  is  $50^\circ$ . Draw a sketch of the new situation. The magnitudes of the forces are  $|\mathbf{F}_{AB}| = 100$  kN and  $|\mathbf{F}_{AC}| = 60$  kN. Graphically determine the magnitude and direction of the sum of the forces exerted on the pylon by the cables.

**Solution:** Accurately draw the vectors and measure the magnitude and direction of the resultant

$$|\mathbf{F}_{AB} + \mathbf{F}_{AC}| = 146 \text{ kN}$$

$$\alpha = 32^\circ$$

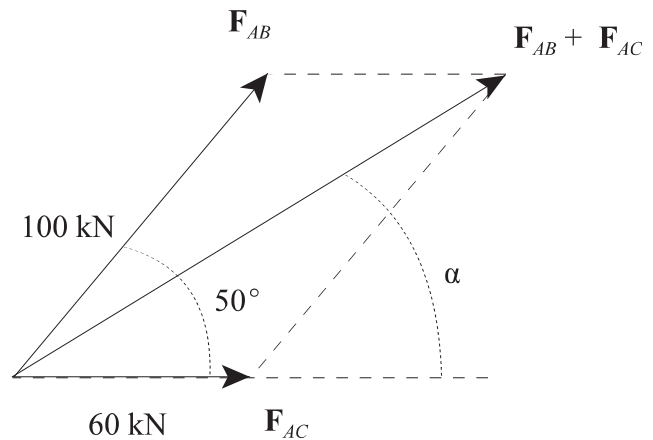

**Problem 2.3** The magnitude  $|\mathbf{F}_A| = 80$  lb and the angle  $\alpha = 65^\circ$ . The magnitude  $|\mathbf{F}_A + \mathbf{F}_B| = 120$  lb. Graphically determine the magnitude of  $\mathbf{F}_B$ .

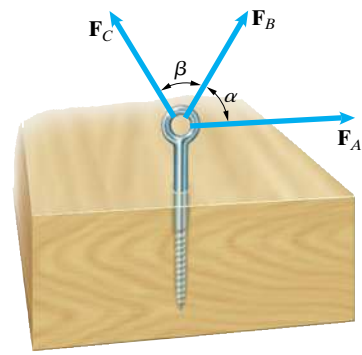

**Solution:** Accurately draw the vectors and measure the magnitude of  $\mathbf{F}_B$ .

$$|\mathbf{F}_B| = 62 \text{ lb}$$

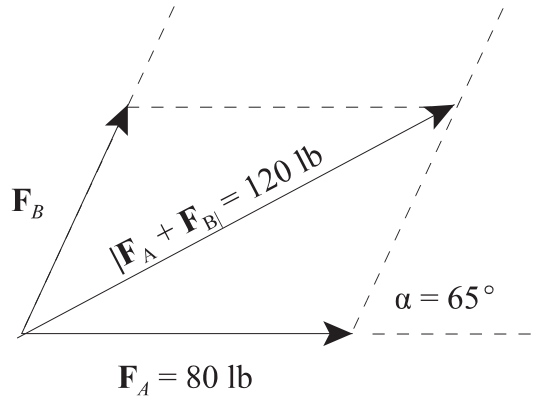

**Problem 2.4** The magnitudes  $|\mathbf{F}_A| = 40$  N,  $|\mathbf{F}_B| = 50$  N, and  $|\mathbf{F}_C| = 40$  N. The angle  $\alpha = 50^\circ$  and  $\beta = 80^\circ$ . Graphically determine the magnitude of  $\mathbf{F}_A + \mathbf{F}_B + \mathbf{F}_C$ .

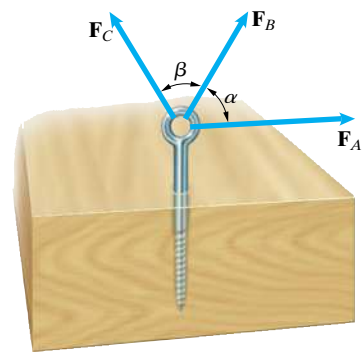

**Solution:** Accurately draw the vectors and measure the magnitude of  $\mathbf{F}_A + \mathbf{F}_B + \mathbf{F}_C$ .

$$R = |\mathbf{F}_A + \mathbf{F}_B + \mathbf{F}_C| = 83 \text{ N}$$

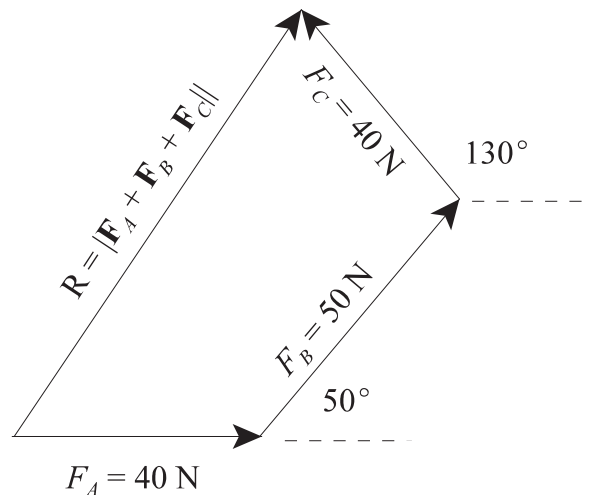

**Problem 2.5** The magnitudes  $|\mathbf{F}_A| = |\mathbf{F}_B| = |\mathbf{F}_C| = 100$  lb, and the angles  $\alpha = 30^\circ$ . Graphically determine the value of the angle  $\beta$  for which the magnitude  $|\mathbf{F}_A + \mathbf{F}_B + \mathbf{F}_C|$  is a minimum and the minimum value of  $|\mathbf{F}_A + \mathbf{F}_B + \mathbf{F}_C|$ .

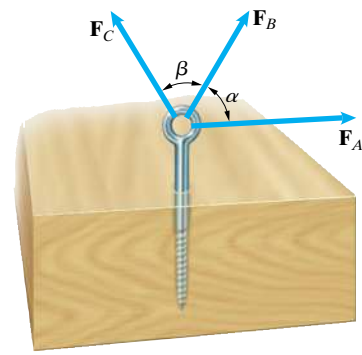

**Solution:** For a minimum, the vector  $\mathbf{F}_C$  must point back to the origin.

$R =  \mathbf{F}_A + \mathbf{F}_B + \mathbf{F}_C  = 93.2$ lb $\beta = 165^\circ$
---

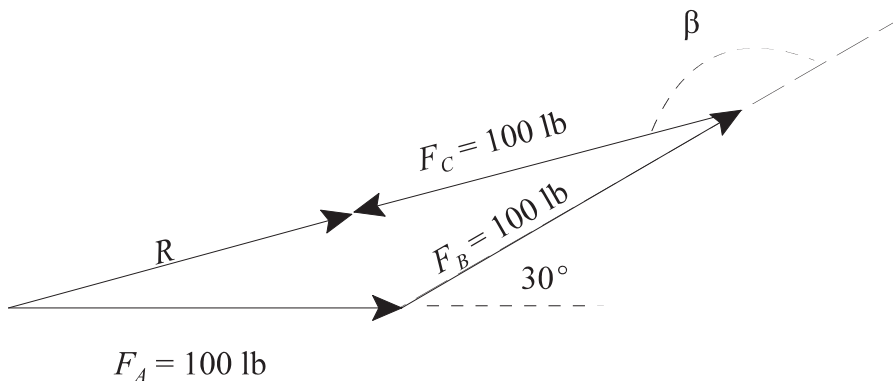

**Problem 2.6** The angle  $\theta = 50^\circ$ . Graphically determine the magnitude of the vector  $\mathbf{r}_{AC}$ .

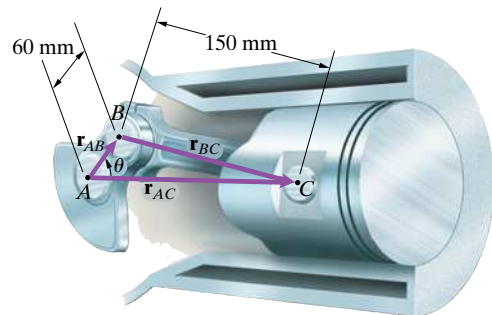

**Solution:** Draw the vectors accurately and then measure  $|\mathbf{r}_{AC}|$ .

$ \mathbf{r}_{AC}  = 181$ mm
------------------------------

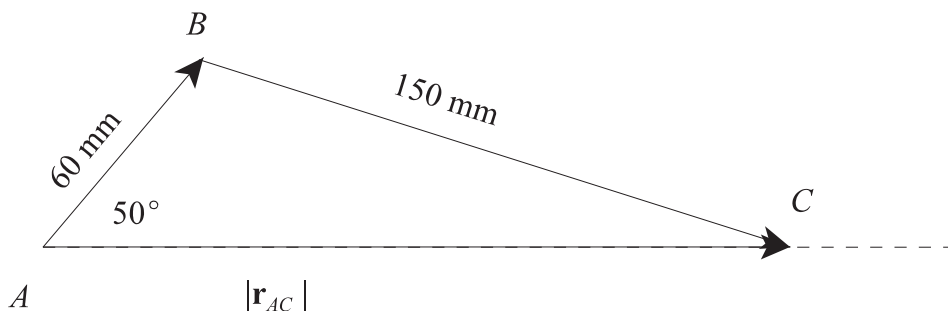

**Problem 2.7** The vectors  $\mathbf{F}_A$  and  $\mathbf{F}_B$  represent the forces exerted on the pulley by the belt. Their magnitudes are  $|\mathbf{F}_A| = 80\text{ N}$  and  $|\mathbf{F}_B| = 60\text{ N}$ . Graphically determine the magnitude of the total force the belt exerts on the pulley.

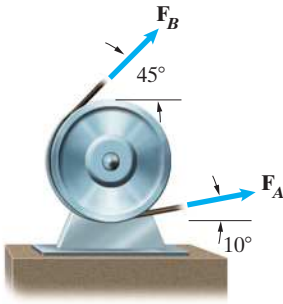

**Solution:** Draw the vectors accurately and then measure  $|\mathbf{F}_A + \mathbf{F}_B|$ .

$$|\mathbf{F}_A + \mathbf{F}_B| = 134\text{ N}$$

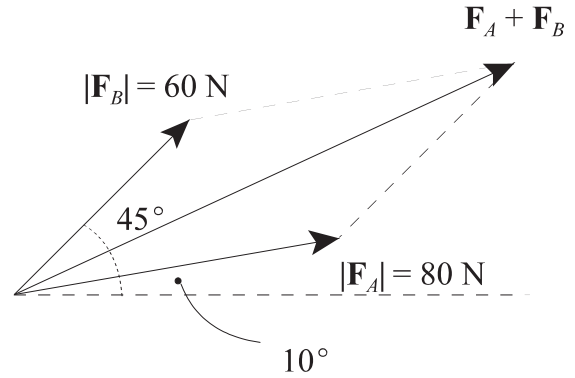

**Problem 2.8** The sum of the forces  $\mathbf{F}_A + \mathbf{F}_B + \mathbf{F}_C = \mathbf{0}$ . The magnitude  $|\mathbf{F}_A| = 100\text{ N}$  and the angle  $\alpha = 60^\circ$ . Graphically determine the magnitudes  $|\mathbf{F}_B|$  and  $|\mathbf{F}_C|$ .

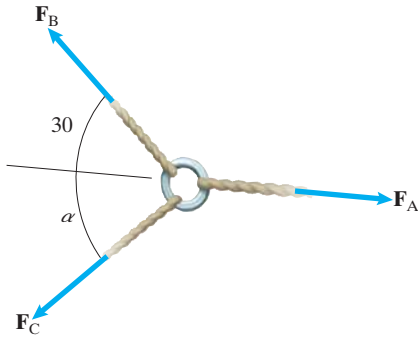

**Solution:** Draw the vectors so that they add to zero.

$$|\mathbf{F}_B| = 86.6\text{ N}, |\mathbf{F}_C| = 50.0\text{ N}$$

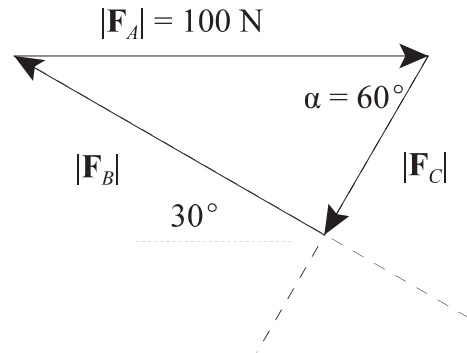

**Problem 2.9** The sum of the forces  $\mathbf{F}_A + \mathbf{F}_B + \mathbf{F}_C = \mathbf{0}$ . The magnitudes  $|\mathbf{F}_A| = 100\text{ N}$  and  $|\mathbf{F}_B| = 80\text{ N}$ . Graphically determine the magnitude  $|\mathbf{F}_C|$  and the angle  $\alpha$ .

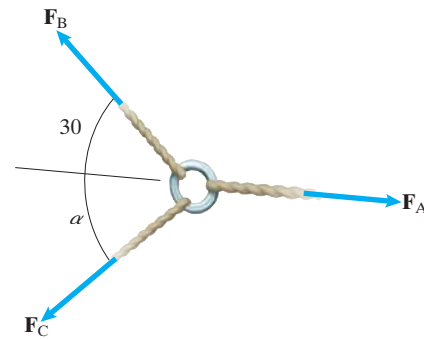

**Solution:** Draw the vectors so that they add to zero.

$$|\mathbf{F}_C| = 50.4\text{ N}, \alpha = 52.5^\circ$$

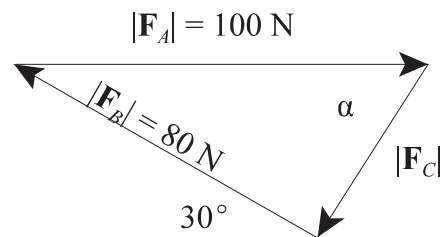

**Problem 2.10** The forces acting on the sailplane are represented by three vectors. The lift  $\mathbf{L}$  and drag  $\mathbf{D}$  are perpendicular. The magnitude of the weight  $\mathbf{W}$  is 500 lb. The sum of the forces  $\mathbf{W} + \mathbf{L} + \mathbf{D} = \mathbf{0}$ . Graphically determine the magnitudes of the lift and drag.

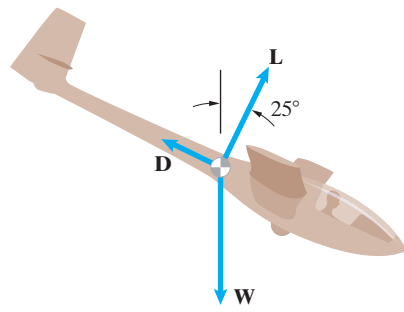

**Solution:** Draw the vectors so that they add to zero. Then measure the unknown magnitudes.

$ \mathbf{L}  = 453 \text{ lb}$ $ \mathbf{D}  = 211 \text{ lb}$
--

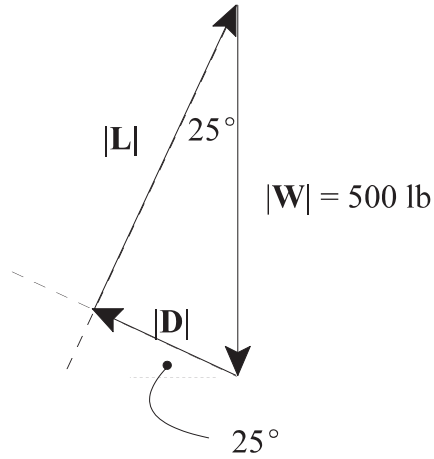

**Problem 2.11** A spherical storage tank is suspended from cables. The tank is subjected to three forces, the forces  $\mathbf{F}_A$  and  $\mathbf{F}_B$  exerted by the cables and its weight  $\mathbf{W}$ . The weight of the tank is  $|\mathbf{W}| = 600 \text{ lb}$ . The vector sum of the forces acting on the tank equals zero. Graphically determine the magnitudes of  $\mathbf{F}_A$  and  $\mathbf{F}_B$ .

**Solution:** Draw the vectors so that they add to zero. Then measure the unknown magnitudes.

$ \mathbf{F}_A  =  \mathbf{F}_B  = 319 \text{ lb}$
--

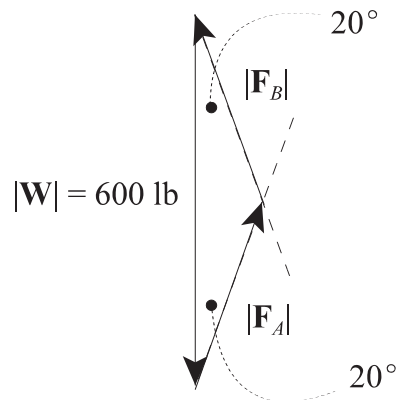
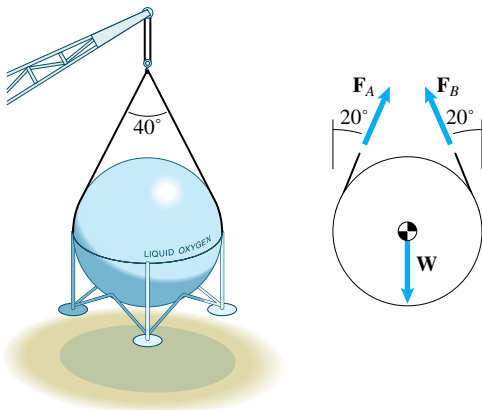

**Problem 2.12** The rope  $ABC$  exerts forces  $\mathbf{F}_{BA}$  and  $\mathbf{F}_{BC}$  of equal magnitude on the block at  $B$ . The magnitude of the total force exerted on the block by the two forces is 200 lb. Graphically determine  $|\mathbf{F}_{BA}|$ .

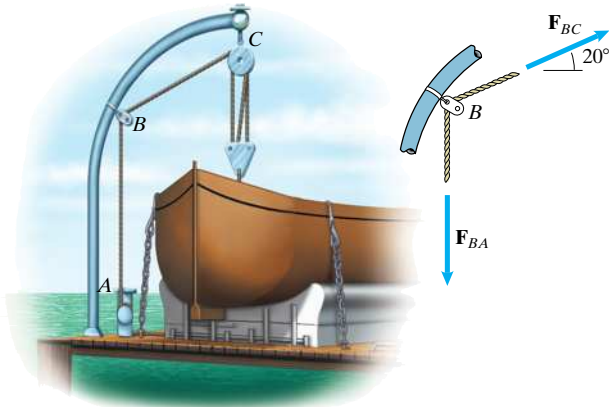

**Solution:** Draw the vectors accurately and then measure the unknown magnitudes.

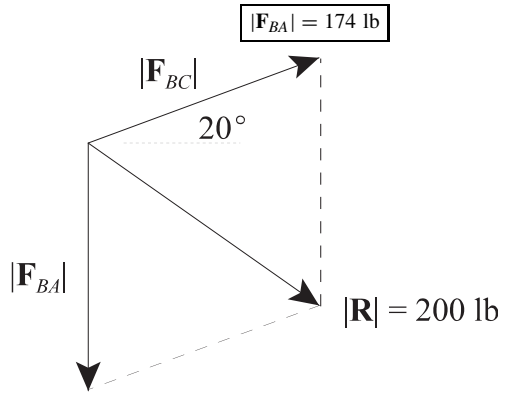

**Problem 2.13** Two snowcats tow an emergency shelter to a new location near McMurdo Station, Antarctica. (The top view is shown. The cables are horizontal.) The total force  $\mathbf{F}_A + \mathbf{F}_B$  exerted on the shelter is in the direction parallel to the line  $L$  and its magnitude is 400 lb. Graphically determine the magnitudes of  $F_A$  and  $F_B$ .

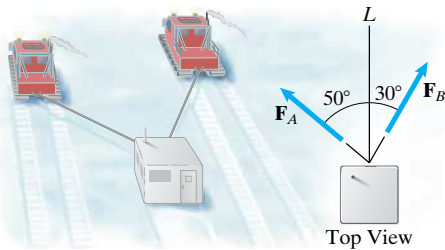

**Solution:** Draw the vectors accurately and then measure the unknown magnitudes.

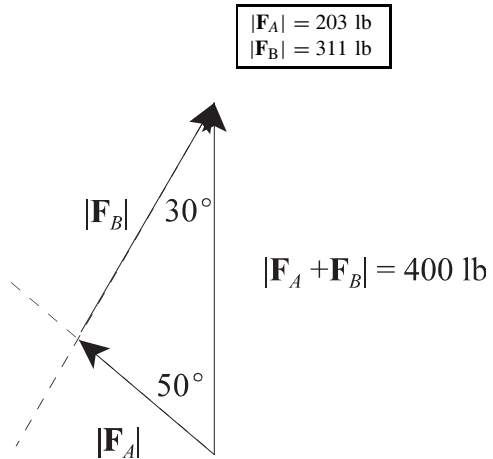

**Problem 2.14** A surveyor determines that the horizontal distance from  $A$  to  $B$  is 400 m and the horizontal distance from  $A$  to  $C$  is 600 m. Graphically determine the magnitude of the vector  $\mathbf{r}_{BC}$  and the angle  $\alpha$ .

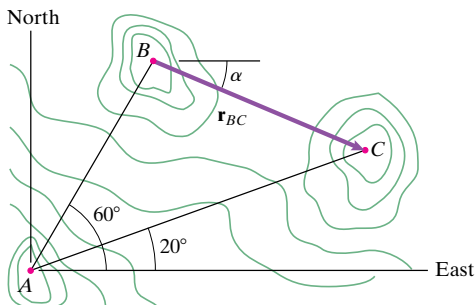

**Solution:** Draw the vectors accurately and then measure the unknown magnitude and angle.

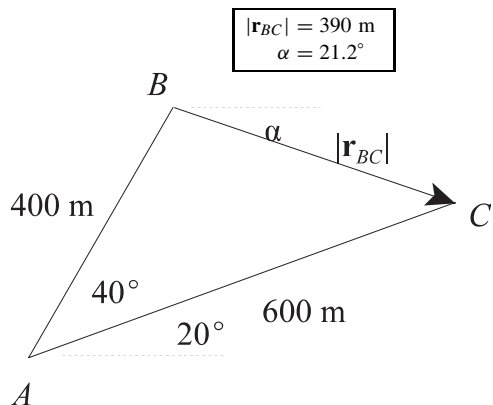

**Problem 2.15** The vector  $\mathbf{r}$  extends from point  $A$  to the midpoint between points  $B$  and  $C$ . Prove that

$$\mathbf{r} = \frac{1}{2}(\mathbf{r}_{AB} + \mathbf{r}_{AC}).$$

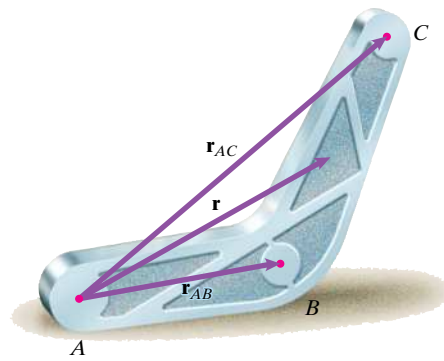

**Solution:** The proof is straightforward:

$$\mathbf{r} = \mathbf{r}_{AB} + \mathbf{r}_{BM}, \text{ and } \mathbf{r} = \mathbf{r}_{AC} + \mathbf{r}_{CM}.$$

Add the two equations and note that  $\mathbf{r}_{BM} + \mathbf{r}_{CM} = 0$ , since the two vectors are equal and opposite in direction.

$$\text{Thus } 2\mathbf{r} = \mathbf{r}_{AC} + \mathbf{r}_{AB}, \text{ or } \mathbf{r} = \left(\frac{1}{2}\right)(\mathbf{r}_{AC} + \mathbf{r}_{AB})$$

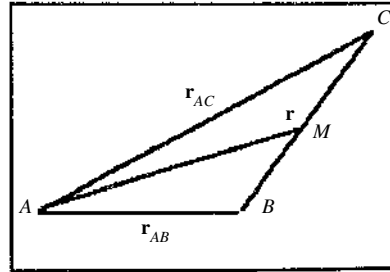

**Problem 2.16** By drawing sketches of the vectors, explain why

$$\mathbf{U} + (\mathbf{V} + \mathbf{W}) = (\mathbf{U} + \mathbf{V}) + \mathbf{W}.$$

**Solution:** Additive associativity for vectors is usually given as an axiom in the theory of vector algebra, and of course axioms are not subject to proof. However we can by sketches show that associativity for vector addition is intuitively reasonable: Given the three vectors to be added, (a) shows the addition first of  $\mathbf{V} + \mathbf{W}$ , and then the addition of  $\mathbf{U}$ . The result is the vector  $\mathbf{U} + (\mathbf{V} + \mathbf{W})$ .

(b) shows the addition of  $\mathbf{U} + \mathbf{V}$ , and then the addition of  $\mathbf{W}$ , leading to the result  $(\mathbf{U} + \mathbf{V}) + \mathbf{W}$ .

The final vector in the two sketches is the same vector, illustrating that associativity of vector addition is intuitively reasonable.

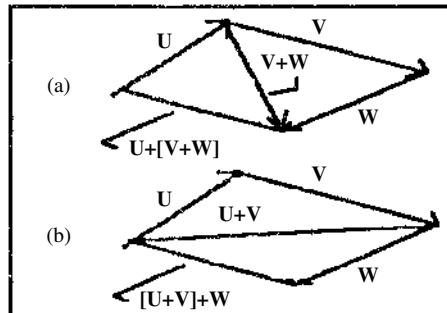

**Problem 2.17** A force  $\mathbf{F} = 40 \mathbf{i} - 20 \mathbf{j}$  (N). What is its magnitude  $|\mathbf{F}|$ ?

**Solution:**  $|\mathbf{F}| = \sqrt{40^2 + 20^2} = 44.7 \text{ N}$

**Strategy:** The magnitude of a vector in terms of its components is given by Eq. (2.8).

**Problem 2.18** An engineer estimating the components of a force  $\mathbf{F} = F_x \mathbf{i} + F_y \mathbf{j}$  acting on a bridge abutment has determined that  $F_x = 130 \text{ MN}$ ,  $|\mathbf{F}| = 165 \text{ MN}$ , and  $F_y$  is negative. What is  $F_y$ ?

**Solution:**

$$|\mathbf{F}| = \sqrt{|\mathbf{F}_x|^2 + |\mathbf{F}_y|^2}$$

$$|\mathbf{F}_y| = \sqrt{|\mathbf{F}|^2 - |\mathbf{F}_x|^2} = \sqrt{(165 \text{ MN})^2 - (130 \text{ MN})^2} = 101.6 \text{ MN}$$

$$\boxed{F_y = -102 \text{ MN}}$$

**Problem 2.19** A support is subjected to a force  $\mathbf{F} = F_x \mathbf{i} + 80\mathbf{j}$  (N). If the support will safely support a force of 100 N, what is the allowable range of values of the component  $F_x$ ?

**Solution:** Use the definition of magnitude in Eq. (2.8) and reduce algebraically.

$$100 \geq \sqrt{(F_x)^2 + (80)^2}, \text{ from which } (100)^2 - (80)^2 \geq (F_x)^2.$$

$$\text{Thus } |F_x| \leq \sqrt{3600}, \text{ or } \boxed{-60 \leq (F_x) \leq +60 \text{ (N)}}$$

**Problem 2.20** If  $\mathbf{F}_A = 600\mathbf{i} - 800\mathbf{j}$  (kip) and  $\mathbf{F}_B = 200\mathbf{i} - 200\mathbf{j}$  (kip), what is the magnitude of the force  $\mathbf{F} = \mathbf{F}_A - 2\mathbf{F}_B$ ?

**Solution:** Take the scalar multiple of  $\mathbf{F}_B$ , add the components of the two forces as in Eq. (2.9), and use the definition of the magnitude.  $\mathbf{F} = (600 - 2(200))\mathbf{i} + (-800 - 2(-200))\mathbf{j} = 200\mathbf{i} - 400\mathbf{j}$

$$\boxed{|\mathbf{F}| = \sqrt{(200)^2 + (-400)^2} = 447.2 \text{ kip}}$$

**Problem 2.21** The forces acting on the sailplane are its weight  $\mathbf{W} = -500\mathbf{j}$ (lb), the drag  $\mathbf{D} = -200\mathbf{i} + 100\mathbf{j}$ (lb) and the lift  $\mathbf{L}$ . The sum of the forces  $\mathbf{W} + \mathbf{L} + \mathbf{D} = \mathbf{0}$ . Determine the components and the magnitude of  $\mathbf{L}$ .

**Solution:**

$$\mathbf{L} = -\mathbf{W} - \mathbf{D} = -(-500\mathbf{j}) - (-200\mathbf{i} + 100\mathbf{j}) = 200\mathbf{i} + 400\mathbf{j}(\text{lb})$$

$$|\mathbf{L}| = \sqrt{(200 \text{ lb})^2 + (400 \text{ lb})^2} = 447 \text{ lb}$$

$$\boxed{\mathbf{L} = 200\mathbf{i} + 400\mathbf{j}(\text{lb}), |\mathbf{L}| = 447 \text{ lb}}$$

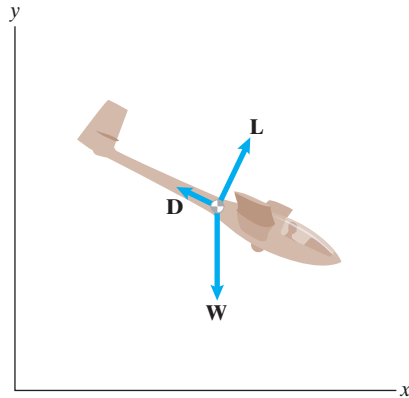



**Problem 2.22** Two perpendicular vectors  $\mathbf{U}$  and  $\mathbf{V}$  lie in the  $x$ - $y$  plane. The vector  $\mathbf{U} = 6\mathbf{i} - 8\mathbf{j}$  and  $|\mathbf{V}| = 20$ . What are the components of  $\mathbf{V}$ ? (Notice that this problem has two answers.)

**Solution:** The two possible values of  $\mathbf{V}$  are shown in the sketch. The strategy is to (a) determine the unit vector associated with  $\mathbf{U}$ , (b) express this vector in terms of an angle, (c) add  $\pm 90^\circ$  to this angle, (d) determine the two unit vectors perpendicular to  $\mathbf{U}$ , and (e) calculate the components of the two possible values of  $\mathbf{V}$ . The unit vector parallel to  $\mathbf{U}$  is

$$\mathbf{e}_U = \frac{6\mathbf{i}}{\sqrt{6^2 + (-8)^2}} - \frac{8\mathbf{j}}{\sqrt{6^2 + (-8)^2}} = 0.6\mathbf{i} - 0.8\mathbf{j}$$

Expressed in terms of an angle,

$$\mathbf{e}_U = \mathbf{i} \cos \alpha - \mathbf{j} \sin \alpha = \mathbf{i} \cos(53.1^\circ) - \mathbf{j} \sin(53.1^\circ)$$

Add  $\pm 90^\circ$  to find the two unit vectors that are perpendicular to this unit vector:

$$\mathbf{e}_{p1} = \mathbf{i} \cos(143.1^\circ) - \mathbf{j} \sin(143.1^\circ) = -0.8\mathbf{i} - 0.6\mathbf{j}$$

$$\mathbf{e}_{p2} = \mathbf{i} \cos(-36.9^\circ) - \mathbf{j} \sin(-36.9^\circ) = 0.8\mathbf{i} + 0.6\mathbf{j}$$

Take the scalar multiple of these unit vectors to find the two vectors perpendicular to  $\mathbf{U}$ .

$$\mathbf{V}_1 = |\mathbf{V}|(-0.8\mathbf{i} - 0.6\mathbf{j}) = -16\mathbf{i} - 12\mathbf{j}.$$

The components are  $V_x = -16$ ,  $V_y = -12$

$$\mathbf{V}_2 = |\mathbf{V}|(0.8\mathbf{i} + 0.6\mathbf{j}) = 16\mathbf{i} + 12\mathbf{j}.$$

The components are  $V_x = 16$ ,  $V_y = 12$

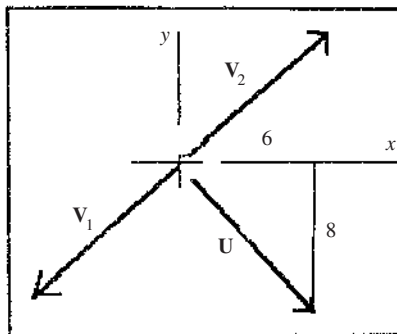

**Problem 2.23** A fish exerts a 10-lb force on the line that is represented by the vector  $\mathbf{F}$ . Express  $\mathbf{F}$  in terms of components using the coordinate system shown.

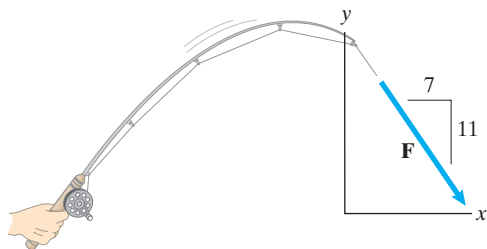

**Solution:** We can use similar triangles to determine the components of  $\mathbf{F}$ .

$$\mathbf{F} = (10 \text{ lb}) \left( \frac{7}{\sqrt{7^2 + 11^2}} \mathbf{i} - \frac{11}{\sqrt{7^2 + 11^2}} \mathbf{j} \right) = (5.37\mathbf{i} - 8.44\mathbf{j}) \text{ lb}$$

$$\mathbf{F} = (5.37\mathbf{i} - 8.44\mathbf{j}) \text{ lb}$$

**Problem 2.24** A man exerts a 60-lb force  $\mathbf{F}$  to push a crate onto a truck. (a) Express  $\mathbf{F}$  in terms of components using the coordinate system shown. (b) The weight of the crate is 100 lb. Determine the magnitude of the sum of the forces exerted by the man and the crate's weight.

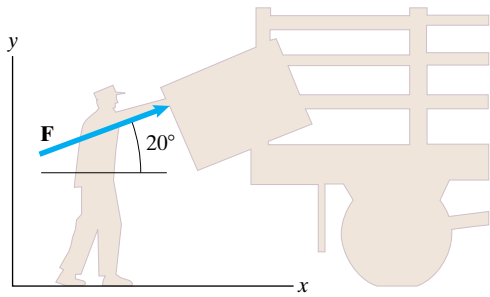

**Solution:**

$$(a) \mathbf{F} = (60 \text{ lb})(\cos 20^\circ \mathbf{i} + \sin 20^\circ \mathbf{j}) = (56.4\mathbf{i} + 20.5\mathbf{j}) \text{ lb}$$

$$\boxed{\mathbf{F} = (56.4\mathbf{i} + 20.5\mathbf{j}) \text{ lb}}$$

$$(b) \mathbf{W} = -(100 \text{ lb})\mathbf{j}$$

$$\mathbf{F} + \mathbf{W} = (56.4\mathbf{i} + [20.5 - 100]\mathbf{j}) \text{ lb} = (56.4\mathbf{i} - 79.5\mathbf{j}) \text{ lb}$$

$$|\mathbf{F} + \mathbf{W}| = \sqrt{(56.4 \text{ lb})^2 + (-79.5 \text{ lb})^2} = 97.4 \text{ lb}$$

$$\boxed{|\mathbf{F} + \mathbf{W}| = 97.4 \text{ lb}}$$

**Problem 2.25** The missile's engine exerts a 260-kN force  $\mathbf{F}$ . (a) Express  $\mathbf{F}$  in terms of components using the coordinate system shown. (b) The mass of the missile is 8800 kg. Determine the magnitude of the sum of the forces exerted by the engine and the missile's weight.

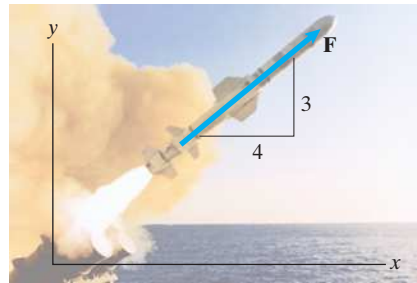

**Solution:**

(a) We can use similar triangles to determine the components of  $\mathbf{F}$ .

$$\mathbf{F} = (260 \text{ kN}) \left( \frac{4}{\sqrt{4^2 + 3^2}} \mathbf{i} + \frac{3}{\sqrt{4^2 + 3^2}} \mathbf{j} \right) = (208\mathbf{i} + 156\mathbf{j}) \text{ kN}$$

$$\boxed{\mathbf{F} = (208\mathbf{i} + 156\mathbf{j}) \text{ kN}}$$

(b) The missile's weight  $\mathbf{W}$  can be expressed in component and then added to the force  $\mathbf{F}$ .

$$\mathbf{W} = -(8800 \text{ kg})(9.81 \text{ m/s}^2)\mathbf{j} = -(86.3 \text{ kN})\mathbf{j}$$

$$\mathbf{F} + \mathbf{W} = (208\mathbf{i} + [156 - 86.3]\mathbf{j}) \text{ kN} = (208\mathbf{i} - 69.7\mathbf{j}) \text{ kN}$$

$$|\mathbf{F} + \mathbf{W}| = \sqrt{(208 \text{ kN})^2 + (-69.7 \text{ kN})^2} = 219 \text{ kN}$$

$$\boxed{|\mathbf{F} + \mathbf{W}| = 219 \text{ kN}}$$

**Problem 2.26** For the truss shown, express the position vector  $\mathbf{r}_{AD}$  from point A to point D in terms of components. Use your result to determine the distance from point A to point D.

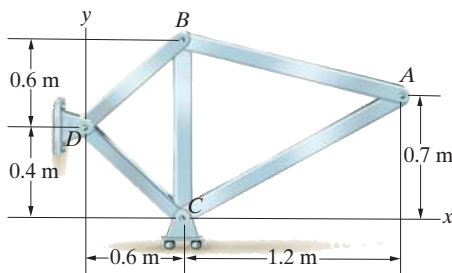

**Solution:** Coordinates  $A(1.8, 0.7) \text{ m}$ ,  $D(0, 0.4) \text{ m}$

$$\mathbf{r}_{AD} = (0 - 1.8 \text{ m})\mathbf{i} + (0.4 \text{ m} - 0.7 \text{ m})\mathbf{j} = (-1.8\mathbf{i} - 0.3\mathbf{j}) \text{ m}$$

$$r_{AD} = \sqrt{(-1.8 \text{ m})^2 + (-0.3 \text{ m})^2} = 1.825 \text{ m}$$

**Problem 2.27** The points  $A, B, \dots$  are the joints of the hexagonal structural element. Let  $\mathbf{r}_{AB}$  be the position vector from joint  $A$  to joint  $B$ ,  $\mathbf{r}_{AC}$  the position vector from joint  $A$  to joint  $C$ , and so forth. Determine the components of the vectors  $\mathbf{r}_{AC}$  and  $\mathbf{r}_{AF}$ .

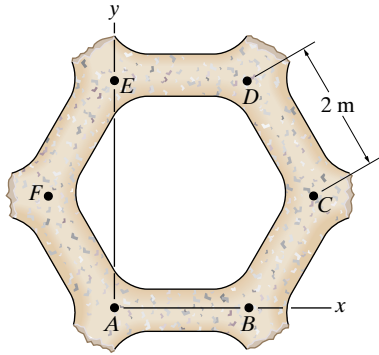

**Solution:** Use the  $xy$  coordinate system shown and find the locations of  $C$  and  $F$  in those coordinates. The coordinates of the points in this system are the scalar components of the vectors  $\mathbf{r}_{AC}$  and  $\mathbf{r}_{AF}$ . For  $\mathbf{r}_{AC}$ , we have

$$\begin{aligned}\mathbf{r}_{AC} &= \mathbf{r}_{AB} + \mathbf{r}_{BC} = (x_B - x_A)\mathbf{i} + (y_B - y_A)\mathbf{j} \\ &\quad + (x_C - x_B)\mathbf{i} + (y_C - y_B)\mathbf{j}\end{aligned}$$

$$\begin{aligned}\text{or} \quad \mathbf{r}_{AC} &= (2m - 0)\mathbf{i} + (0 - 0)\mathbf{j} + (2m \cos 60^\circ - 0)\mathbf{i} \\ &\quad + (2m \sin 60^\circ - 0)\mathbf{j},\end{aligned}$$

giving

$$\mathbf{r}_{AC} = (2m + 2m \cos 60^\circ)\mathbf{i} + (2m \sin 60^\circ)\mathbf{j}. \text{ For } \mathbf{r}_{AF}, \text{ we have}$$

$$\begin{aligned}\mathbf{r}_{AF} &= (x_F - x_A)\mathbf{i} + (y_F - y_A)\mathbf{j} \\ &= (-2m \cos 60^\circ - 0)\mathbf{i} + (2m \sin 60^\circ - 0)\mathbf{j}.\end{aligned}$$

**Problem 2.28** For the hexagonal structural element in Problem 2.27, determine the components of the vector  $\mathbf{r}_{AB} - \mathbf{r}_{BC}$ .

**Solution:**  $\mathbf{r}_{AB} - \mathbf{r}_{BC}$ .

The angle between  $BC$  and the  $x$ -axis is  $60^\circ$ .

$$\mathbf{r}_{BC} = 2 \cos(60^\circ)\mathbf{i} + 2(\sin(60^\circ)\mathbf{j}) \text{ (m)}$$

$$\mathbf{r}_{BC} = 1\mathbf{i} + 1.73\mathbf{j} \text{ (m)}$$

$$\mathbf{r}_{AB} - \mathbf{r}_{BC} = 2\mathbf{i} - 1\mathbf{i} - 1.73\mathbf{j} \text{ (m)}$$

$$\mathbf{r}_{AB} - \mathbf{r}_{BC} = 1\mathbf{i} - 1.73\mathbf{j} \text{ (m)}$$

**Problem 2.29** The coordinates of point  $A$  are (1.8, 3.0) ft. The  $y$  coordinate of point  $B$  is 0.6 ft. The vector  $\mathbf{r}_{AB}$  has the same direction as the unit vector  $\mathbf{e}_{AB} = 0.616\mathbf{i} - 0.788\mathbf{j}$ . What are the components of  $\mathbf{r}_{AB}$ ?

**Solution:** The vector  $\mathbf{r}_{AB}$  can be written two ways.

$$\mathbf{r}_{AB} = |\mathbf{r}_{AB}|(0.616\mathbf{i} - 0.788\mathbf{j}) = (B_x - A_x)\mathbf{i} + (B_y - A_y)\mathbf{j}$$

Comparing the two expressions we have

$$(B_y - A_y) = (0.6 - 3.0)\text{ft} = -(0.788)|\mathbf{r}_{AB}|$$

$$|\mathbf{r}_{AB}| = \frac{-2.4 \text{ ft}}{-0.788} = 3.05 \text{ ft}$$

Thus

$$\mathbf{r}_{AB} = |\mathbf{r}_{AB}|(0.616\mathbf{i} - 0.788\mathbf{j}) = (3.05 \text{ ft})(0.616\mathbf{i} - 0.788\mathbf{j}) = (1.88\mathbf{i} - 2.40\mathbf{j}) \text{ ft}$$

$$\boxed{\mathbf{r}_{AB} = (1.88\mathbf{i} - 2.40\mathbf{j}) \text{ ft}}$$

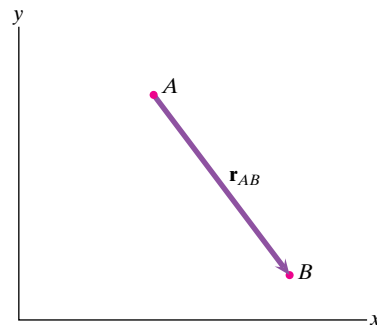

**Problem 2.30** (a) Express the position vector from point  $A$  of the front-end loader to point  $B$  in terms of components.

(b) Express the position vector from point  $B$  to point  $C$  in terms of components.

(c) Use the results of (a) and (b) to determine the distance from point  $A$  to point  $C$ .

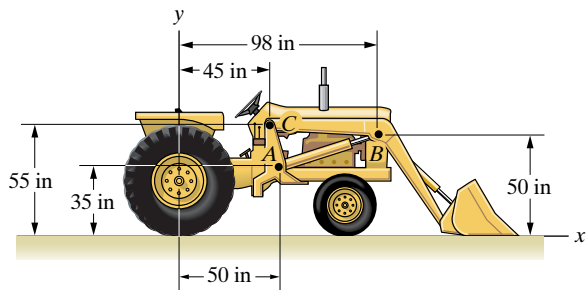

**Solution:** The coordinates are  $A(50, 35)$ ;  $B(98, 50)$ ;  $C(45, 55)$ .

(a) The vector from point  $A$  to  $B$ :

$$\mathbf{r}_{AB} = (98 - 50)\mathbf{i} + (50 - 35)\mathbf{j} = 48\mathbf{i} + 15\mathbf{j} \text{ (in)}$$

(b) The vector from point  $B$  to  $C$  is

$$\mathbf{r}_{BC} = (45 - 98)\mathbf{i} + (55 - 50)\mathbf{j} = -53\mathbf{i} + 5\mathbf{j} \text{ (in)}$$

(c) The distance from  $A$  to  $C$  is the magnitude of the sum of the vectors,

$$\mathbf{r}_{AC} = \mathbf{r}_{AB} + \mathbf{r}_{BC} = (48 - 53)\mathbf{i} + (15 + 5)\mathbf{j} = -5\mathbf{i} + 20\mathbf{j}$$

The distance from  $A$  to  $C$  is

$$|\mathbf{r}_{AC}| = \sqrt{(-5)^2 + (20)^2} = 20.62 \text{ in}$$

**Problem 2.31** In Active Example 2.3, the cable  $AB$  exerts a 900-N force on the top of the tower. Suppose that the attachment point  $B$  is moved in the horizontal direction farther from the tower, and assume that the magnitude of the force  $\mathbf{F}$  the cable exerts on the top of the tower is proportional to the length of the cable. (a) What is the distance from the tower to point  $B$  if the magnitude of the force is 1000 N? (b) Express the 1000-N force  $\mathbf{F}$  in terms of components using the coordinate system shown.

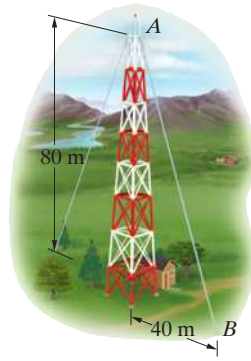

**Solution:** In the new problem assume that point  $B$  is located a distance  $d$  away from the base. The lengths in the original problem and in the new problem are given by

$$L_{\text{original}} = \sqrt{(40 \text{ m})^2 + (80 \text{ m})^2} = \sqrt{8000 \text{ m}^2}$$

$$L_{\text{new}} = \sqrt{d^2 + (80 \text{ m})^2}$$

(a) The force is proportional to the length. Therefore

$$1000 \text{ N} = (900 \text{ N}) \frac{\sqrt{d^2 + (80 \text{ m})^2}}{\sqrt{8000 \text{ m}^2}}$$

$$d = \sqrt{(8000 \text{ m}^2) \left( \frac{1000 \text{ N}}{900 \text{ N}} \right)^2 - (80 \text{ m})^2} = 59.0 \text{ m}$$

$$\boxed{d = 59.0 \text{ m}}$$

(b) The force  $\mathbf{F}$  is then

$$\mathbf{F} = (1000 \text{ N}) \left( \frac{d}{\sqrt{d^2 + (80 \text{ m})^2}} \mathbf{i} - \frac{80 \text{ m}}{\sqrt{d^2 + (80 \text{ m})^2}} \mathbf{j} \right)$$

$$= (593\mathbf{i} - 805\mathbf{j}) \text{ N}$$

$$\boxed{\mathbf{F} = (593\mathbf{i} - 805\mathbf{j}) \text{ N}}$$

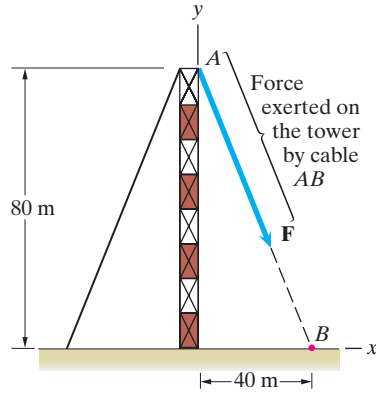

**Problem 2.32** Determine the position vector  $\mathbf{r}_{AB}$  in terms of its components if (a)  $\theta = 30^\circ$ , (b)  $\theta = 225^\circ$ .

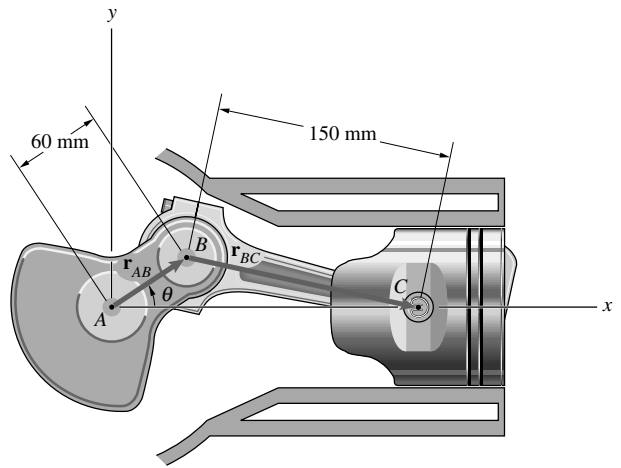

**Solution:**

(a)  $\mathbf{r}_{AB} = (60) \cos(30^\circ)\mathbf{i} + (60) \sin(30^\circ)\mathbf{j}$ , or

$$\mathbf{r}_{AB} = 51.96\mathbf{i} + 30\mathbf{j} \text{ mm. And}$$

(b)  $\mathbf{r}_{AB} = (60) \cos(225^\circ)\mathbf{i} + (60) \sin(225^\circ)\mathbf{j}$  or

$$\mathbf{r}_{AB} = -42.4\mathbf{i} - 42.4\mathbf{j} \text{ mm.}$$

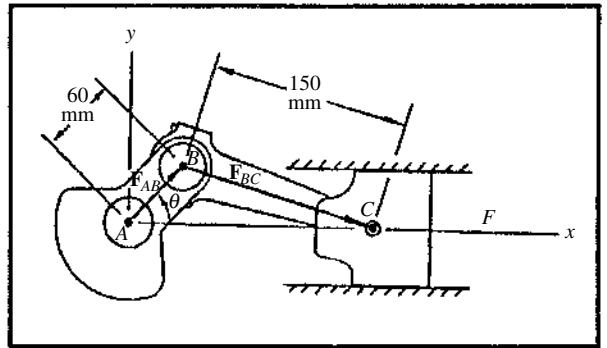

**Problem 2.33** In Example 2.4, the coordinates of the fixed point A are (17, 1) ft. The driver lowers the bed of the truck into a new position in which the coordinates of point B are (9, 3) ft. The magnitude of the force  $F$  exerted on the bed by the hydraulic cylinder when the bed is in the new position is 4800 lb. Draw a sketch of the new situation. Express  $F$  in terms of components.

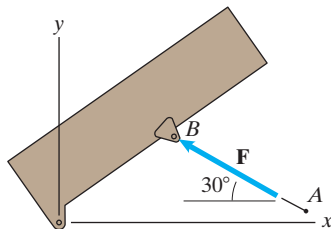
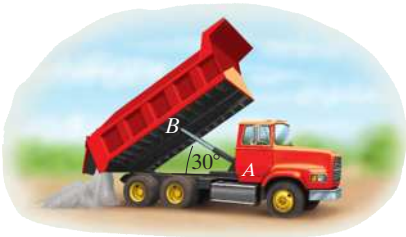

**Solution:**

$$\theta = \tan^{-1} \left( \frac{2 \text{ ft}}{8 \text{ ft}} \right) = 14.04^\circ$$

$$\mathbf{F} = 4800 \text{ lb}(-\cos \theta \mathbf{i} + \sin \theta \mathbf{j}).$$

$$\mathbf{F} = (-4660\mathbf{i} + 1160\mathbf{j}) \text{ lb}$$

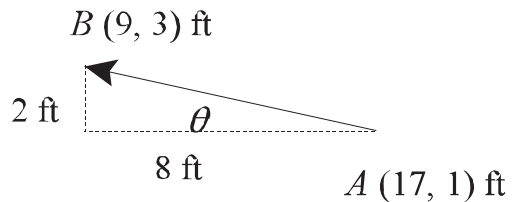

**Problem 2.34** A surveyor measures the location of point  $A$  and determines that  $\mathbf{r}_{OA} = 400\mathbf{i} + 800\mathbf{j}$  (m). He wants to determine the location of a point  $B$  so that  $|\mathbf{r}_{AB}| = 400$  m and  $|\mathbf{r}_{OA} + \mathbf{r}_{AB}| = 1200$  m. What are the cartesian coordinates of point  $B$ ?

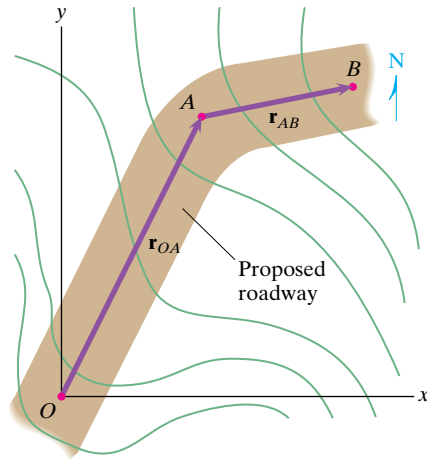

**Solution:** Two possibilities are: The point  $B$  lies west of point  $A$ , or point  $B$  lies east of point  $A$ , as shown. The strategy is to determine the unknown angles  $\alpha$ ,  $\beta$ , and  $\theta$ . The magnitude of  $OA$  is

$$|\mathbf{r}_{OA}| = \sqrt{(400)^2 + (800)^2} = 894.4.$$

The angle  $\beta$  is determined by

$$\tan \beta = \frac{800}{400} = 2, \quad \beta = 63.4^\circ.$$

The angle  $\alpha$  is determined from the cosine law:

$$\cos \alpha = \frac{(894.4)^2 + (1200)^2 - (400)^2}{2(894.4)(1200)} = 0.9689.$$

$$\alpha = 14.3^\circ. \quad \text{The angle } \theta \text{ is } \theta = \beta \pm \alpha = 49.12^\circ, 77.74^\circ.$$

The two possible sets of coordinates of point  $B$  are

$$\begin{cases} \mathbf{r}_{OB} = 1200(\mathbf{i} \cos 77.7^\circ + \mathbf{j} \sin 77.7^\circ) = 254.67\mathbf{i} + 1172.66\mathbf{j} \text{ (m)} \\ \mathbf{r}_{OB} = 1200(\mathbf{i} \cos 49.1^\circ + \mathbf{j} \sin 49.1^\circ) = 785.33\mathbf{i} + 907.34\mathbf{j} \text{ (m)} \end{cases}$$

The two possibilities lead to  $B(254.7 \text{ m}, 1172.7 \text{ m})$  or  $B(785.3 \text{ m}, 907.3 \text{ m})$

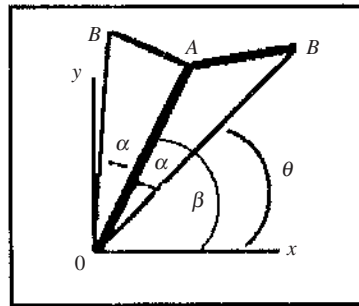

**Problem 2.35** The magnitude of the position vector  $\mathbf{r}_{BA}$  from point  $B$  to point  $A$  is 6 m and the magnitude of the position vector  $\mathbf{r}_{CA}$  from point  $C$  to point  $A$  is 4 m. What are the components of  $\mathbf{r}_{BA}$ ?

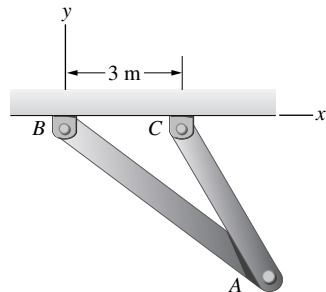

**Solution:** The coordinates are:  $A(x_A, y_A)$ ,  $B(0, 0)$ ,  $C(3 \text{ m}, 0)$

Thus

$$\mathbf{r}_{BA} = (x_A - 0)\mathbf{i} + (y_A - 0)\mathbf{j} \Rightarrow (6 \text{ m})^2 = x_A^2 + y_A^2$$

$$\mathbf{r}_{CA} = (x_A - 3 \text{ m})\mathbf{i} + (y_A - 0)\mathbf{j} \Rightarrow (4 \text{ m})^2 = (x_A - 3 \text{ m})^2 + y_A^2$$

Solving these two equations, we find  $x_A = 4.833 \text{ m}$ ,  $y_A = \pm 3.555 \text{ m}$ . We choose the “-” sign and find

$$\mathbf{r}_{BA} = (4.83\mathbf{i} - 3.56\mathbf{j}) \text{ m}$$

**Problem 2.36** In Problem 2.35, determine the components of a unit vector  $\mathbf{e}_{CA}$  that points from point  $C$  toward point  $A$ .

**Strategy:** Determine the components of  $\mathbf{r}_{CA}$  and then divide the vector  $\mathbf{r}_{CA}$  by its magnitude.

**Solution:** From the previous problem we have

$$\mathbf{r}_{CA} = (1.83\mathbf{i} - 3.56\mathbf{j}) \text{ m}, \quad r_{CA} = \sqrt{1.83^2 + 3.56^2} \text{ m} = 3.56 \text{ m}$$

Thus

$$\mathbf{e}_{CA} = \frac{\mathbf{r}_{CA}}{r_{CA}} = (0.458\mathbf{i} - 0.889\mathbf{j})$$

**Problem 2.37** The  $x$  and  $y$  coordinates of points  $A$ ,  $B$ , and  $C$  of the sailboat are shown.

(a) Determine the components of a unit vector that is parallel to the forestay  $AB$  and points from  $A$  toward  $B$ .

(b) Determine the components of a unit vector that is parallel to the backstay  $BC$  and points from  $C$  toward  $B$ .

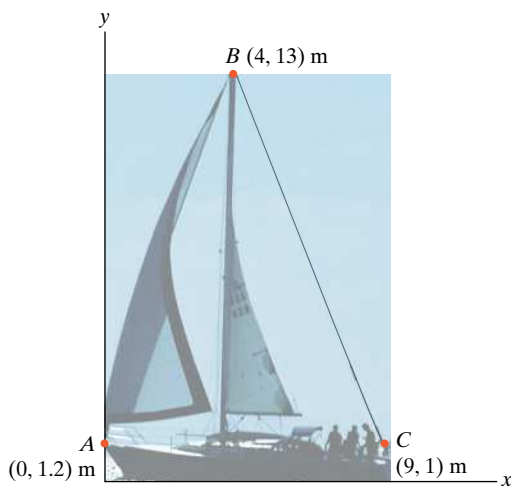

**Solution:**

$$\mathbf{r}_{AB} = (x_B - x_A)\mathbf{i} + (y_B - y_A)\mathbf{j}$$

$$\mathbf{r}_{CB} = (x_B - x_C)\mathbf{i} + (y_C - y_B)\mathbf{j}$$

Points are:  $A(0, 1.2)$ ,  $B(4, 13)$  and  $C(9, 1)$

Substituting, we get

$$\mathbf{r}_{AB} = 4\mathbf{i} + 11.8\mathbf{j} \text{ (m)}, \quad |\mathbf{r}_{AB}| = 12.46 \text{ (m)}$$

$$\mathbf{r}_{CB} = -5\mathbf{i} + 12\mathbf{j} \text{ (m)}, \quad |\mathbf{r}_{CB}| = 13 \text{ (m)}$$

The unit vectors are given by

$$\mathbf{e}_{AB} = \frac{\mathbf{r}_{AB}}{|\mathbf{r}_{AB}|} \quad \text{and} \quad \mathbf{e}_{CB} = \frac{\mathbf{r}_{CB}}{|\mathbf{r}_{CB}|}$$

Substituting, we get

$$\mathbf{e}_{AB} = 0.321\mathbf{i} + 0.947\mathbf{j}$$

$$\mathbf{e}_{CB} = -0.385\mathbf{i} + 0.923\mathbf{j}$$



**Problem 2.38** The length of the bar  $AB$  is 0.6 m. Determine the components of a unit vector  $\mathbf{e}_{AB}$  that points from point  $A$  toward point  $B$ .

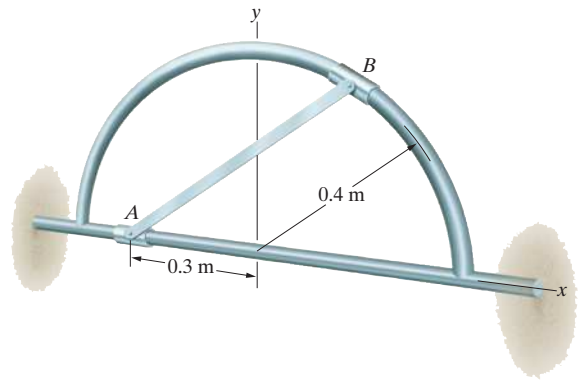

**Solution:** We need to find the coordinates of point  $B(x, y)$

We have the two equations

$$(0.3 \text{ m} + x)^2 + y^2 = (0.6 \text{ m})^2$$

$$x^2 + y^2 = (0.4 \text{ m})^2$$

Solving we find

$$x = 0.183 \text{ m}, \quad y = 0.356 \text{ m}$$

Thus

$$\mathbf{e}_{AB} = \frac{\mathbf{r}_{AB}}{r_{AB}} = \frac{(0.183 \text{ m} - [-0.3 \text{ m}])\mathbf{i} + (0.356 \text{ m})\mathbf{j}}{\sqrt{(0.183 \text{ m} + 0.3 \text{ m})^2 + (0.356 \text{ m})^2}} = (0.806\mathbf{i} + 0.593\mathbf{j})$$

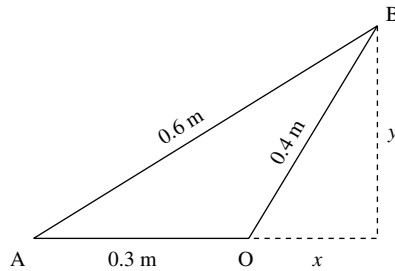

**Problem 2.39** Determine the components of a unit vector that is parallel to the hydraulic actuator  $BC$  and points from  $B$  toward  $C$ .

**Solution:** Point  $B$  is at  $(0.75, 0)$  and point  $C$  is at  $(0, 0.6)$ . The vector

$$\mathbf{r}_{BC} = (x_C - x_B)\mathbf{i} + (y_C - y_B)\mathbf{j}$$

$$\mathbf{r}_{BC} = (0 - 0.75)\mathbf{i} + (0.6 - 0)\mathbf{j} \text{ (m)}$$

$$\mathbf{r}_{BC} = -0.75\mathbf{i} + 0.6\mathbf{j} \text{ (m)}$$

$$|\mathbf{r}_{BC}| = \sqrt{(0.75)^2 + (0.6)^2} = 0.960 \text{ (m)}$$

$$\mathbf{e}_{BC} = \frac{\mathbf{r}_{BC}}{|\mathbf{r}_{BC}|} = \frac{-0.75}{0.96}\mathbf{i} + \frac{0.6}{0.96}\mathbf{j}$$

$$\mathbf{e}_{BC} = -0.781\mathbf{i} + 0.625\mathbf{j}$$

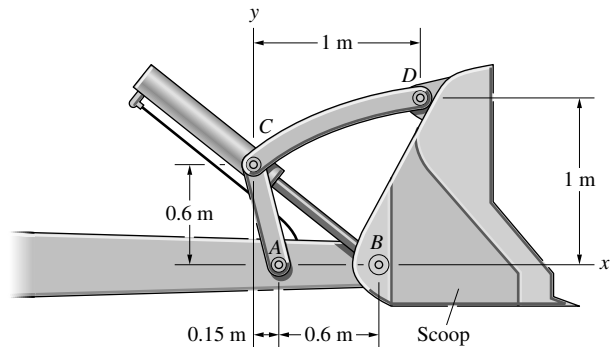

**Problem 2.40** The hydraulic actuator  $BC$  in Problem 2.39 exerts a 1.2-kN force  $\mathbf{F}$  on the joint at  $C$  that is parallel to the actuator and points from  $B$  toward  $C$ . Determine the components of  $\mathbf{F}$ .

**Solution:** From the solution to Problem 2.39,

$$\mathbf{e}_{BC} = -0.781\mathbf{i} + 0.625\mathbf{j}$$

The vector  $\mathbf{F}$  is given by  $\mathbf{F} = |\mathbf{F}|\mathbf{e}_{BC}$

$$\mathbf{F} = (1.2)(-0.781\mathbf{i} + 0.625\mathbf{j}) \text{ (k} \cdot \text{N)}$$

$$\mathbf{F} = -937\mathbf{i} + 750\mathbf{j} \text{ (N)}$$

**Problem 2.41** A surveyor finds that the length of the line  $OA$  is 1500 m and the length of line  $OB$  is 2000 m.

- Determine the components of the position vector from point  $A$  to point  $B$ .
- Determine the components of a unit vector that points from point  $A$  toward point  $B$ .

**Solution:** We need to find the coordinates of points  $A$  and  $B$

$$\mathbf{r}_{OA} = 1500 \cos 60^\circ \mathbf{i} + 1500 \sin 60^\circ \mathbf{j}$$

$$\mathbf{r}_{OA} = 750\mathbf{i} + 1299\mathbf{j} \text{ (m)}$$

Point  $A$  is at (750, 1299) (m)

$$\mathbf{r}_{OB} = 2000 \cos 30^\circ \mathbf{i} + 2000 \sin 30^\circ \mathbf{j} \text{ (m)}$$

$$\mathbf{r}_{OB} = 1732\mathbf{i} + 1000\mathbf{j} \text{ (m)}$$

Point  $B$  is at (1732, 1000) (m)

- The vector from  $A$  to  $B$  is

$$\mathbf{r}_{AB} = (x_B - x_A)\mathbf{i} + (y_B - y_A)\mathbf{j}$$

$$\mathbf{r}_{AB} = 982\mathbf{i} - 299\mathbf{j} \text{ (m)}$$

- The unit vector  $\mathbf{e}_{AB}$  is

$$\mathbf{e}_{AB} = \frac{\mathbf{r}_{AB}}{|\mathbf{r}_{AB}|} = \frac{982\mathbf{i} - 299\mathbf{j}}{1026.6}$$

$$\mathbf{e}_{AB} = 0.957\mathbf{i} - 0.291\mathbf{j}$$

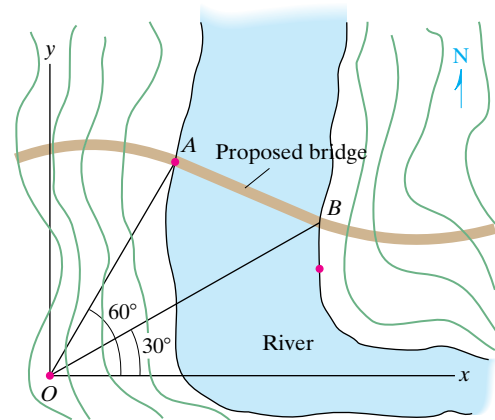

**Problem 2.42** The magnitudes of the forces exerted by the cables are  $|\mathbf{T}_1| = 2800$  lb,  $|\mathbf{T}_2| = 3200$  lb,  $|\mathbf{T}_3| = 4000$  lb, and  $|\mathbf{T}_4| = 5000$  lb. What is the magnitude of the total force exerted by the four cables?

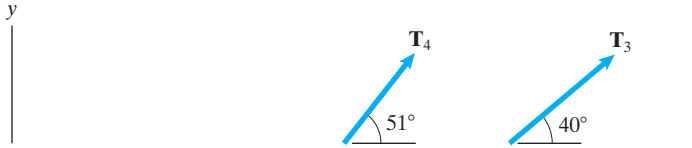

**Solution:** The  $x$ -component of the total force is

$$T_x = |\mathbf{T}_1| \cos 9^\circ + |\mathbf{T}_2| \cos 29^\circ + |\mathbf{T}_3| \cos 40^\circ + |\mathbf{T}_4| \cos 51^\circ$$

$$T_x = (2800 \text{ lb}) \cos 9^\circ + (3200 \text{ lb}) \cos 29^\circ + (4000 \text{ lb}) \cos 40^\circ + (5000 \text{ lb}) \cos 51^\circ$$

$$T_x = 11,800 \text{ lb}$$

The  $y$ -component of the total force is

$$T_y = |\mathbf{T}_1| \sin 9^\circ + |\mathbf{T}_2| \sin 29^\circ + |\mathbf{T}_3| \sin 40^\circ + |\mathbf{T}_4| \sin 51^\circ$$

$$T_y = (2800 \text{ lb}) \sin 9^\circ + (3200 \text{ lb}) \sin 29^\circ + (4000 \text{ lb}) \sin 40^\circ + (5000 \text{ lb}) \sin 51^\circ$$

$$T_y = 8450 \text{ lb}$$

The magnitude of the total force is

$$|\mathbf{T}| = \sqrt{T_x^2 + T_y^2} = \sqrt{(11,800 \text{ lb})^2 + (8450 \text{ lb})^2} = 14,500 \text{ lb} \quad \boxed{|\mathbf{T}| = 14,500 \text{ lb}}$$

**Problem 2.43** The tensions in the four cables are equal:  $|\mathbf{T}_1| = |\mathbf{T}_2| = |\mathbf{T}_3| = |\mathbf{T}_4| = T$ . Determine the value of  $T$  so that the four cables exert a total force of 12,500-lb magnitude on the support.

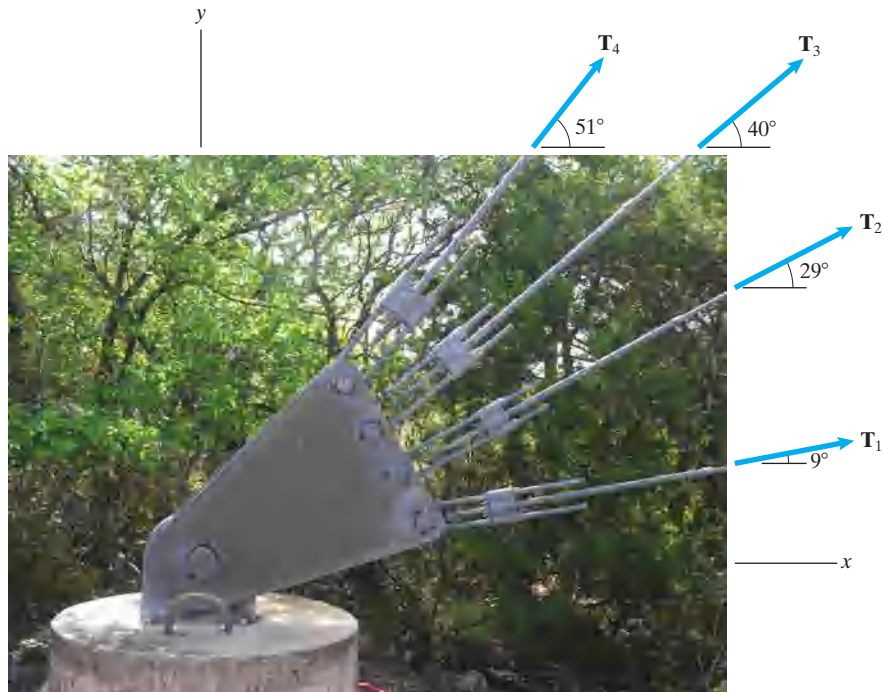

**Solution:** The  $x$ -component of the total force is

$$T_x = T \cos 9^\circ + T \cos 29^\circ + T \cos 40^\circ + T \cos 51^\circ$$

$$T_x = 3.26T$$

The  $y$ -component of the total force is

$$T_y = T \sin 9^\circ + T \sin 29^\circ + T \sin 40^\circ + T \sin 51^\circ$$

$$T_y = 2.06T$$

The magnitude of the total force is

$$|\mathbf{T}| = \sqrt{T_x^2 + T_y^2} = \sqrt{(3.26T)^2 + (2.06T)^2} = 3.86T = 12,500 \text{ lb}$$

Solving for  $T$  we find  $T = 3240 \text{ lb}$

**Problem 2.44** The rope  $ABC$  exerts forces  $\mathbf{F}_{BA}$  and  $\mathbf{F}_{BC}$  on the block at  $B$ . Their magnitudes are equal:  $|\mathbf{F}_{BA}| = |\mathbf{F}_{BC}|$ . The magnitude of the total force exerted on the block at  $B$  by the rope is  $|\mathbf{F}_{BA} + \mathbf{F}_{BC}| = 920 \text{ N}$ . Determine  $|\mathbf{F}_{BA}|$  by expressing the forces  $\mathbf{F}_{BA}$  and  $\mathbf{F}_{BC}$  in terms of components.

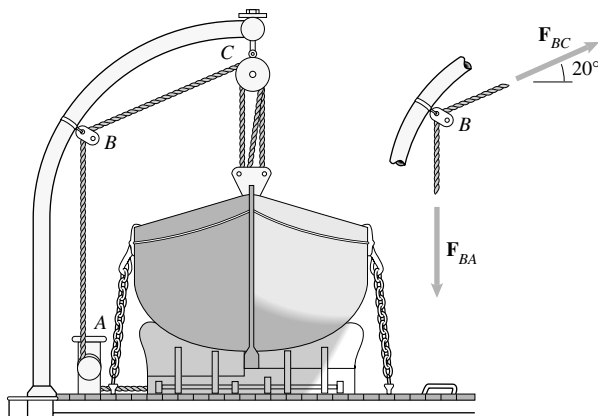

**Solution:**

$$\mathbf{F}_{BC} = F(\cos 20^\circ \mathbf{i} + \sin 20^\circ \mathbf{j})$$

$$\mathbf{F}_{BA} = F(-\mathbf{j})$$

$$\mathbf{F}_{BC} + \mathbf{F}_{BA} = F(\cos 20^\circ \mathbf{i} + [\sin 20^\circ - 1]\mathbf{j})$$

Therefore

$$(920 \text{ N})^2 = F^2(\cos^2 20^\circ + [\sin 20^\circ - 1]^2) \Rightarrow F = 802 \text{ N}$$

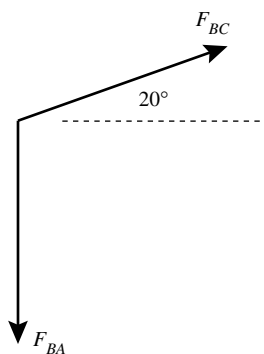

**Problem 2.45** The magnitude of the horizontal force  $\mathbf{F}_1$  is 5 kN and  $\mathbf{F}_1 + \mathbf{F}_2 + \mathbf{F}_3 = \mathbf{0}$ . What are the magnitudes of  $\mathbf{F}_2$  and  $\mathbf{F}_3$ ?

**Solution:** Using components we have

$$\sum F_x : 5 \text{ kN} + F_2 \cos 45^\circ - F_3 \cos 30^\circ = 0$$

$$\sum F_y : -F_2 \sin 45^\circ + F_3 \sin 30^\circ = 0$$

Solving simultaneously yields:

$$\Rightarrow F_2 = 9.66 \text{ kN}, \quad F_3 = 13.66 \text{ kN}$$

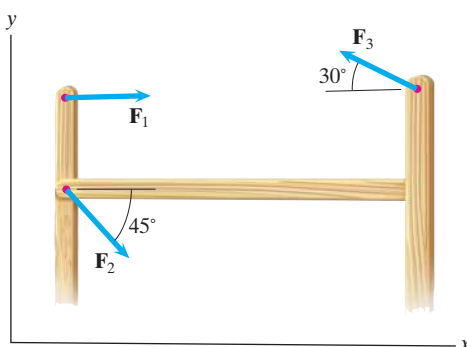

**Problem 2.46** Four groups engage in a tug-of-war. The magnitudes of the forces exerted by groups  $B$ ,  $C$ , and  $D$  are  $|\mathbf{F}_B| = 800$  lb,  $|\mathbf{F}_C| = 1000$  lb,  $|\mathbf{F}_D| = 900$  lb. If the vector sum of the four forces equals zero, what are the magnitude of  $\mathbf{F}_A$  and the angle  $\alpha$ ?

**Solution:** The strategy is to use the angles and magnitudes to determine the force vector components, to solve for the unknown force  $\mathbf{F}_A$  and then take its magnitude. The force vectors are

$$\mathbf{F}_B = 800(\mathbf{i} \cos 110^\circ + \mathbf{j} \sin 110^\circ) = -273.6\mathbf{i} + 751.75\mathbf{j}$$

$$\mathbf{F}_C = 1000(\mathbf{i} \cos 30^\circ + \mathbf{j} \sin 30^\circ) = 866\mathbf{i} + 500\mathbf{j}$$

$$\mathbf{F}_D = 900(\mathbf{i} \cos(-20^\circ) + \mathbf{j} \sin(-20^\circ)) = 845.72\mathbf{i} - 307.8\mathbf{j}$$

$$\mathbf{F}_A = |\mathbf{F}_A|(\mathbf{i} \cos(180 + \alpha) + \mathbf{j} \sin(180 + \alpha))$$

$$= |\mathbf{F}_A|(-\mathbf{i} \cos \alpha - \mathbf{j} \sin \alpha)$$

The sum vanishes:

$$\mathbf{F}_A + \mathbf{F}_B + \mathbf{F}_C + \mathbf{F}_D = \mathbf{i}(1438.1 - |\mathbf{F}_A| \cos \alpha)$$

$$+ \mathbf{j}(944 - |\mathbf{F}_A| \sin \alpha) = 0$$

From which  $\mathbf{F}_A = 1438.1\mathbf{i} + 944\mathbf{j}$ . The magnitude is

$$|\mathbf{F}_A| = \sqrt{(1438)^2 + (944)^2} = 1720 \text{ lb}$$

The angle is:  $\tan \alpha = \frac{944}{1438} = 0.6565$ , or  $\alpha = 33.3^\circ$

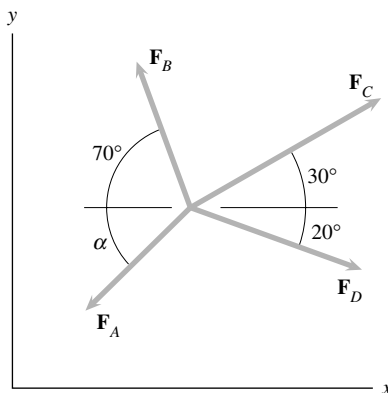

**Problem 2.47** In Example 2.5, suppose that the attachment point of cable A is moved so that the angle between the cable and the wall increases from  $40^\circ$  to  $55^\circ$ . Draw a sketch showing the forces exerted on the hook by the two cables. If you want the total force  $\mathbf{F}_A + \mathbf{F}_B$  to have a magnitude of 200 lb and be in the direction perpendicular to the wall, what are the necessary magnitudes of  $\mathbf{F}_A$  and  $\mathbf{F}_B$ ?

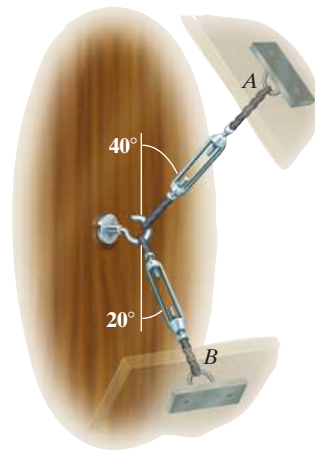

**Solution:** Let  $F_A$  and  $F_B$  be the magnitudes of  $\mathbf{F}_A$  and  $\mathbf{F}_B$ . The component of the total force parallel to the wall must be zero. And the sum of the components perpendicular to the wall must be 200 lb.

$$F_A \cos 55^\circ - F_B \cos 20^\circ = 0$$

$$F_A \sin 55^\circ + F_B \sin 20^\circ = 200 \text{ lb}$$

Solving we find

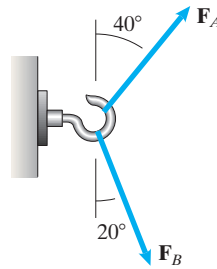
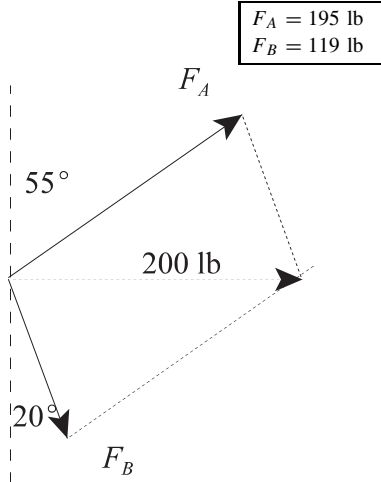

**Problem 2.48** The bracket must support the two forces shown, where  $|\mathbf{F}_1| = |\mathbf{F}_2| = 2 \text{ kN}$ . An engineer determines that the bracket will safely support a total force of magnitude  $3.5 \text{ kN}$  in any direction. Assume that  $0 \leq \alpha \leq 90^\circ$ . What is the safe range of the angle  $\alpha$ ?

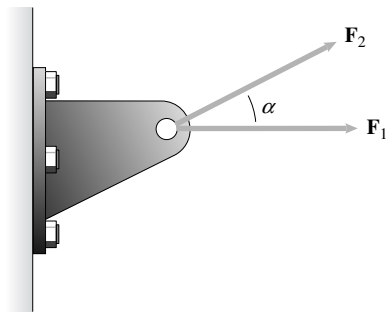

**Solution:**

$$\sum F_x : (2 \text{ kN}) + (2 \text{ kN}) \cos \alpha = (2 \text{ kN})(1 + \cos \alpha)$$

$$\sum F_y : (2 \text{ kN}) \sin \alpha$$

Thus the total force has a magnitude given by

$$F = 2 \text{ kN} \sqrt{(1 + \cos \alpha)^2 + (\sin \alpha)^2} = 2 \text{ kN} \sqrt{2 + 2 \cos \alpha} = 3.5 \text{ kN}$$

Thus when we are at the limits we have

$$2 + 2 \cos \alpha = \left( \frac{3.5 \text{ kN}}{2 \text{ kN}} \right)^2 = \frac{49}{16} \Rightarrow \cos \alpha = \frac{17}{32} \Rightarrow \alpha = 57.9^\circ$$

In order to be safe we must have

$$\boxed{57.9^\circ \leq \alpha \leq 90^\circ}$$

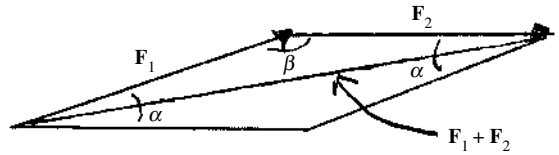



**Problem 2.49** The figure shows three forces acting on a joint of a structure. The magnitude of  $\mathbf{F}_C$  is 60 kN, and  $\mathbf{F}_A + \mathbf{F}_B + \mathbf{F}_C = \mathbf{0}$ . What are the magnitudes of  $\mathbf{F}_A$  and  $\mathbf{F}_B$ ?

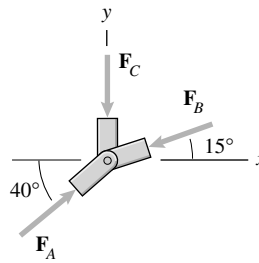

**Solution:** We need to write each force in terms of its components.

$$\mathbf{F}_A = |\mathbf{F}_A| \cos 40^\circ \mathbf{i} + |\mathbf{F}_A| \sin 40^\circ \mathbf{j} \text{ (kN)}$$

$$\mathbf{F}_B = |\mathbf{F}_B| \cos 195^\circ \mathbf{i} + |\mathbf{F}_B| \sin 195^\circ \mathbf{j} \text{ (kN)}$$

$$\mathbf{F}_C = |\mathbf{F}_C| \cos 270^\circ \mathbf{i} + |\mathbf{F}_C| \sin 270^\circ \mathbf{j} \text{ (kN)}$$

$$\text{Thus } \mathbf{F}_C = -60\mathbf{j} \text{ kN}$$

Since  $\mathbf{F}_A + \mathbf{F}_B + \mathbf{F}_C = \mathbf{0}$ , their components in each direction must also sum to zero.

$$\begin{cases} F_{Ax} + F_{Bx} + F_{Cx} = 0 \\ F_{Ay} + F_{By} + F_{Cy} = 0 \end{cases}$$

Thus,

$$\begin{cases} |\mathbf{F}_A| \cos 40^\circ + |\mathbf{F}_B| \cos 195^\circ + 0 = 0 \\ |\mathbf{F}_A| \sin 40^\circ + |\mathbf{F}_B| \sin 195^\circ - 60 \text{ (kN)} = 0 \end{cases}$$

Solving for  $|\mathbf{F}_A|$  and  $|\mathbf{F}_B|$ , we get

$$|\mathbf{F}_A| = 137 \text{ kN}, \quad |\mathbf{F}_B| = 109 \text{ kN}$$

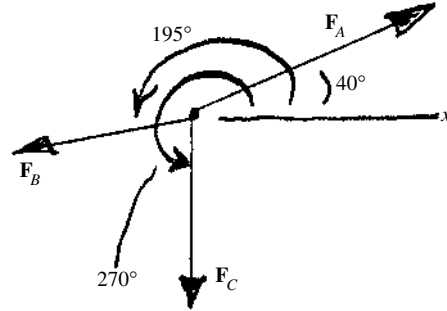

**Problem 2.50** Four forces act on a beam. The vector sum of the forces is zero. The magnitudes  $|\mathbf{F}_B| = 10 \text{ kN}$  and  $|\mathbf{F}_C| = 5 \text{ kN}$ . Determine the magnitudes of  $\mathbf{F}_A$  and  $\mathbf{F}_D$ .

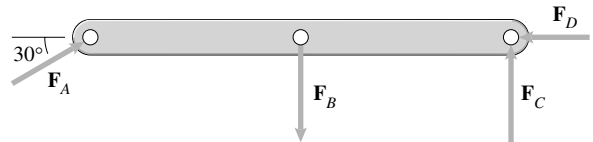

**Solution:** Use the angles and magnitudes to determine the vectors, and then solve for the unknowns. The vectors are:

$$\mathbf{F}_A = |\mathbf{F}_A|(\mathbf{i} \cos 30^\circ + \mathbf{j} \sin 30^\circ) = 0.866|\mathbf{F}_A|\mathbf{i} + 0.5|\mathbf{F}_A|\mathbf{j}$$

$$\mathbf{F}_B = 0\mathbf{i} - 10\mathbf{j}, \quad \mathbf{F}_C = 0\mathbf{i} + 5\mathbf{j}, \quad \mathbf{F}_D = -|\mathbf{F}_D|\mathbf{i} + 0\mathbf{j}.$$

Take the sum of each component in the  $x$ - and  $y$ -directions:

$$\sum \mathbf{F}_x = (0.866|\mathbf{F}_A| - |\mathbf{F}_D|)\mathbf{i} = 0$$

$$\text{and } \sum \mathbf{F}_y = (0.5|\mathbf{F}_A| - (10 - 5))\mathbf{j} = 0.$$

From the second equation we get  $|\mathbf{F}_A| = 10 \text{ kN}$ . Using this value in the first equation, we get  $|\mathbf{F}_D| = 8.7 \text{ kN}$ .

**Problem 2.51** Six forces act on a beam that forms part of a building's frame. The vector sum of the forces is zero. The magnitudes  $|\mathbf{F}_B| = |\mathbf{F}_E| = 20$  kN,  $|\mathbf{F}_C| = 16$  kN, and  $|\mathbf{F}_D| = 9$  kN. Determine the magnitudes of  $\mathbf{F}_A$  and  $\mathbf{F}_G$ .

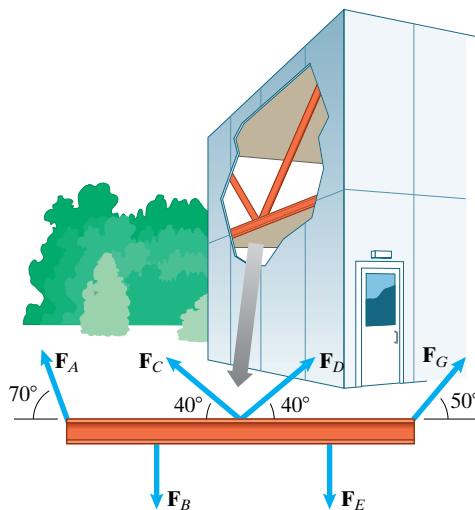

**Solution:** Write each force in terms of its magnitude and direction as

$$\mathbf{F} = |\mathbf{F}| \cos \theta \mathbf{i} + |\mathbf{F}| \sin \theta \mathbf{j}$$

where  $\theta$  is measured counterclockwise from the  $+x$ -axis.

Thus, (all forces in kN)

$$\mathbf{F}_A = |\mathbf{F}_A| \cos 110^\circ \mathbf{i} + |\mathbf{F}_A| \sin 110^\circ \mathbf{j} \text{ (kN)}$$

$$\mathbf{F}_B = 20 \cos 270^\circ \mathbf{i} + 20 \sin 270^\circ \mathbf{j} \text{ (kN)}$$

$$\mathbf{F}_C = 16 \cos 140^\circ \mathbf{i} + 16 \sin 140^\circ \mathbf{j} \text{ (kN)}$$

$$\mathbf{F}_D = 9 \cos 40^\circ \mathbf{i} + 9 \sin 40^\circ \mathbf{j} \text{ (kN)}$$

$$\mathbf{F}_E = 20 \cos 270^\circ \mathbf{i} + 20 \sin 270^\circ \mathbf{j} \text{ (kN)}$$

$$\mathbf{F}_G = |\mathbf{F}_G| \cos 50^\circ \mathbf{i} + |\mathbf{F}_G| \sin 50^\circ \mathbf{j} \text{ (kN)}$$

We know that the  $x$  components and  $y$  components of the forces must add separately to zero.

Thus

$$\begin{cases} F_{Ax} + F_{Bx} + F_{Cx} + F_{Dx} + F_{Ex} + F_{Gx} = 0 \\ F_{Ay} + F_{By} + F_{Cy} + F_{Dy} + F_{Ey} + F_{Gy} = 0 \end{cases}$$

$$\begin{cases} |\mathbf{F}_A| \cos 110^\circ + 0 - 12.26 + 6.89 + 0 + |\mathbf{F}_G| \cos 50^\circ = 0 \\ |\mathbf{F}_A| \sin 110^\circ - 20 + 10.28 + 5.79 - 20 + |\mathbf{F}_G| \sin 50^\circ = 0 \end{cases}$$

Solving, we get

$$|\mathbf{F}_A| = 13.0 \text{ kN} \quad |\mathbf{F}_G| = 15.3 \text{ kN}$$

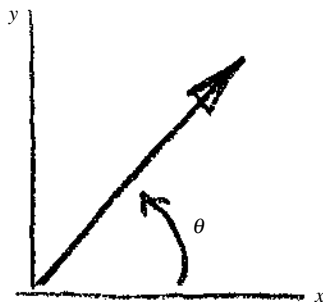

**Problem 2.52** The total weight of the man and parasail is  $|\mathbf{W}| = 230$  lb. The drag force  $\mathbf{D}$  is perpendicular to the lift force  $\mathbf{L}$ . If the vector sum of the three forces is zero, what are the magnitudes of  $\mathbf{L}$  and  $\mathbf{D}$ ?



**Solution:** Let  $L$  and  $D$  be the magnitudes of the lift and drag forces. We can use similar triangles to express the vectors  $\mathbf{L}$  and  $\mathbf{D}$  in terms of components. Then the sum of the forces is zero. Breaking into components we have

$$\frac{2}{\sqrt{2^2 + 5^2}}L - \frac{5}{\sqrt{2^2 + 5^2}}D = 0$$

$$\frac{5}{\sqrt{2^2 + 5^2}}L - \frac{2}{\sqrt{2^2 + 5^2}}D - 230 \text{ lb} = 0$$

Solving we find

$$|\mathbf{D}| = 85.4 \text{ lb}, |\mathbf{L}| = 214 \text{ lb}$$

**Problem 2.53** The three forces acting on the car are shown. The force  $\mathbf{T}$  is parallel to the  $x$  axis and the magnitude of the force  $\mathbf{W}$  is 14 kN. If  $\mathbf{T} + \mathbf{W} + \mathbf{N} = \mathbf{0}$ , what are the magnitudes of the forces  $\mathbf{T}$  and  $\mathbf{N}$ ?

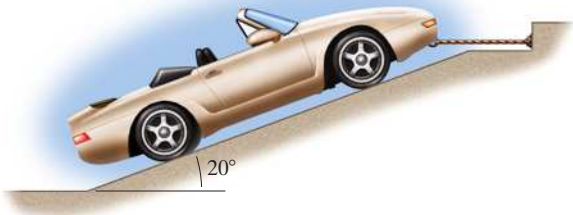

**Solution:**

$$\sum F_x : T - N \sin 20^\circ = 0$$

$$\sum F_y : N \cos 20^\circ - 14 \text{ kN} = 0$$

Solving we find

$$N = 14.90 \text{ N}, T = 5.10 \text{ N}$$

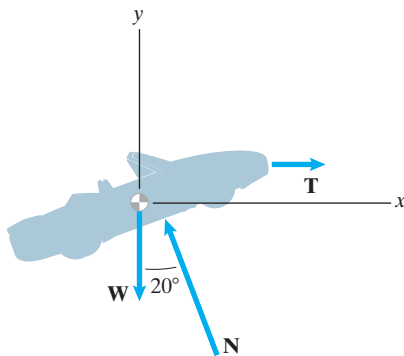

**Problem 2.54** The cables  $A$ ,  $B$ , and  $C$  help support a pillar that forms part of the supports of a structure. The magnitudes of the forces exerted by the cables are equal:  $|\mathbf{F}_A| = |\mathbf{F}_B| = |\mathbf{F}_C|$ . The magnitude of the vector sum of the three forces is 200 kN. What is  $|\mathbf{F}_A|$ ?

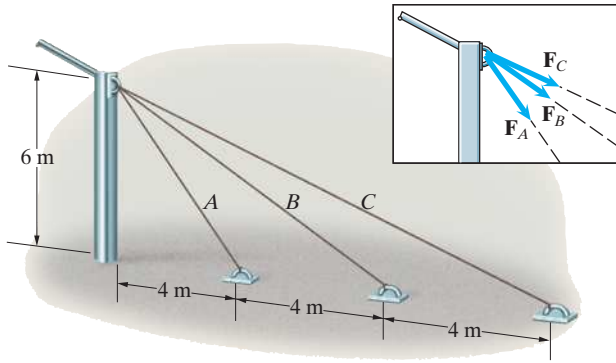

**Solution:** Use the angles and magnitudes to determine the vector components, take the sum, and solve for the unknown. The angles between each cable and the pillar are:

$$\theta_A = \tan^{-1}\left(\frac{4 \text{ m}}{6 \text{ m}}\right) = 33.7^\circ,$$

$$\theta_B = \tan^{-1}\left(\frac{8}{6}\right) = 53.1^\circ$$

$$\theta_C = \tan^{-1}\left(\frac{12}{6}\right) = 63.4^\circ.$$

Measure the angles counterclockwise from the  $x$ -axis. The force vectors acting along the cables are:

$$\mathbf{F}_A = |\mathbf{F}_A|(\mathbf{i} \cos 303.7^\circ + \mathbf{j} \sin 303.7^\circ) = 0.5548|\mathbf{F}_A|\mathbf{i} - 0.8319|\mathbf{F}_A|\mathbf{j}$$

$$\mathbf{F}_B = |\mathbf{F}_B|(\mathbf{i} \cos 323.1^\circ + \mathbf{j} \sin 323.1^\circ) = 0.7997|\mathbf{F}_B|\mathbf{i} - 0.6004|\mathbf{F}_B|\mathbf{j}$$

$$\mathbf{F}_C = |\mathbf{F}_C|(\mathbf{i} \cos 333.4^\circ + \mathbf{j} \sin 333.4^\circ) = 0.8944|\mathbf{F}_C|\mathbf{i} - 0.4472|\mathbf{F}_C|\mathbf{j}$$

The sum of the forces are, noting that each is equal in magnitude, is

$$\sum \mathbf{F} = (2.2489|\mathbf{F}_A|\mathbf{i} - 1.8795|\mathbf{F}_A|\mathbf{j}).$$

The magnitude of the sum is given by the problem:

$$200 = |\mathbf{F}_A|\sqrt{(2.2489)^2 + (1.8795)^2} = 2.931|\mathbf{F}_A|,$$

from which  $|\mathbf{F}_A| = 68.24 \text{ kN}$

**Problem 2.55** The total force exerted on the top of the mast  $B$  by the sailboat's forestay  $AB$  and backstay  $BC$  is  $180\mathbf{i} - 820\mathbf{j}$  (N). What are the magnitudes of the forces exerted at  $B$  by the cables  $AB$  and  $BC$ ?

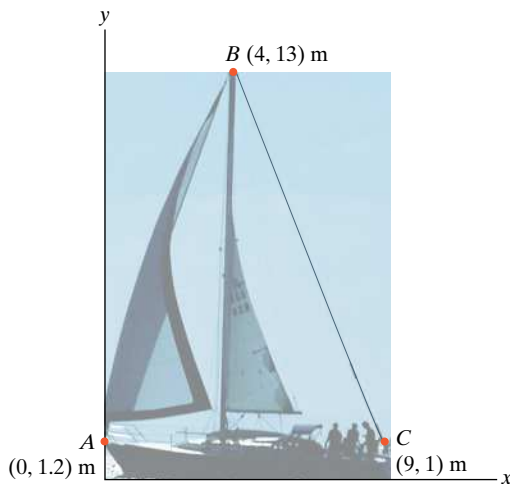

**Solution:** We first identify the forces:

$$\mathbf{F}_{AB} = T_{AB} \frac{(-4.0 \text{ m}\mathbf{i} - 11.8 \text{ m}\mathbf{j})}{\sqrt{(-4.0 \text{ m})^2 + (11.8 \text{ m})^2}}$$

$$\mathbf{F}_{BC} = T_{BC} \frac{(5.0 \text{ m}\mathbf{i} - 12.0 \text{ m}\mathbf{j})}{\sqrt{(5.0 \text{ m})^2 + (-12.0 \text{ m})^2}}$$

Then if we add the force we find

$$\sum F_x: -\frac{4}{\sqrt{155.24}}T_{AB} + \frac{5}{\sqrt{169}}T_{BC} = 180 \text{ N}$$

$$\sum F_y: -\frac{11.8}{\sqrt{155.24}}T_{AB} - \frac{12}{\sqrt{169}}T_{BC} = -820 \text{ N}$$

Solving simultaneously yields:

$$\Rightarrow T_{AB} = 226 \text{ N}, \quad T_{AC} = 657 \text{ N}$$

**Problem 2.56** The structure shown forms part of a truss designed by an architectural engineer to support the roof of an orchestra shell. The members  $AB$ ,  $AC$ , and  $AD$  exert forces  $\mathbf{F}_{AB}$ ,  $\mathbf{F}_{AC}$ , and  $\mathbf{F}_{AD}$  on the joint  $A$ . The magnitude  $|\mathbf{F}_{AB}| = 4$  kN. If the vector sum of the three forces equals zero, what are the magnitudes of  $\mathbf{F}_{AC}$  and  $\mathbf{F}_{AD}$ ?

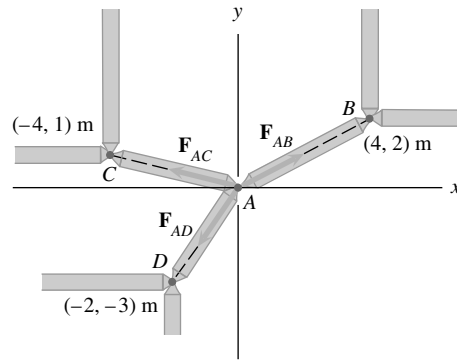

**Solution:** Determine the unit vectors parallel to each force:

$$\mathbf{e}_{AD} = \frac{-2}{\sqrt{2^2 + 3^2}}\mathbf{i} + \frac{-3}{\sqrt{2^2 + 3^2}}\mathbf{j} = -0.5547\mathbf{i} - 0.8320\mathbf{j}$$

$$\mathbf{e}_{AC} = \frac{-4}{\sqrt{4^2 + 1^2}}\mathbf{i} + \frac{1}{\sqrt{4^2 + 1^2}}\mathbf{j} = -0.9701\mathbf{i} + 0.2425\mathbf{j}$$

$$\mathbf{e}_{AB} = \frac{4}{\sqrt{4^2 + 2^2}}\mathbf{i} + \frac{2}{\sqrt{4^2 + 2^2}}\mathbf{j} = 0.89443\mathbf{i} + 0.4472\mathbf{j}$$

The forces are  $\mathbf{F}_{AD} = |\mathbf{F}_{AD}|\mathbf{e}_{AD}$ ,  $\mathbf{F}_{AC} = |\mathbf{F}_{AC}|\mathbf{e}_{AC}$ ,

$\mathbf{F}_{AB} = |\mathbf{F}_{AB}|\mathbf{e}_{AB} = 3.578\mathbf{i} + 1.789\mathbf{j}$ . Since the vector sum of the forces vanishes, the  $x$ - and  $y$ -components vanish separately:

$$\sum \mathbf{F}_x = (-0.5547|\mathbf{F}_{AD}| - 0.9701|\mathbf{F}_{AC}| + 3.578)\mathbf{i} = 0, \text{ and}$$

$$\sum \mathbf{F}_y = (-0.8320|\mathbf{F}_{AD}| + 0.2425|\mathbf{F}_{AC}| + 1.789)\mathbf{j} = 0$$

These simultaneous equations in two unknowns can be solved by any standard procedure. An HP-28S hand held calculator was used here:

The results:  $|\mathbf{F}_{AC}| = 2.108$  kN,  $|\mathbf{F}_{AD}| = 2.764$  kN

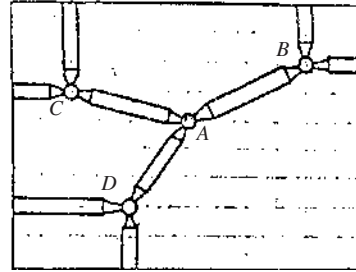

**Problem 2.57** The distance  $s = 45$  in.

- Determine the unit vector  $\mathbf{e}_{BA}$  that points from  $B$  toward  $A$ .
- Use the unit vector you obtained in (a) to determine the coordinates of the collar  $C$ .

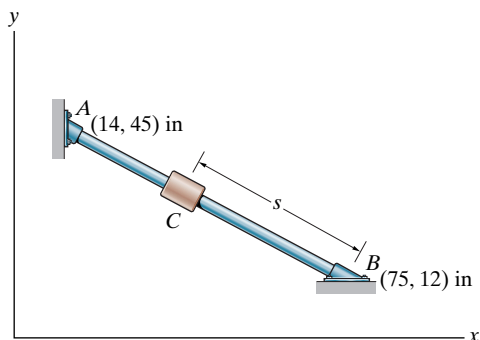

**Solution:**

- The unit vector is the position vector from  $B$  to  $A$  divided by its magnitude

$$\mathbf{r}_{BA} = ([14 - 75]\mathbf{i} + [45 - 12]\mathbf{j})\text{in} = (-61\mathbf{i} + 33\mathbf{j})\text{in}$$

$$|\mathbf{r}_{BA}| = \sqrt{(-61\text{ in})^2 + (33\text{ in})^2} = 69.35\text{ in}$$

$$\mathbf{e}_{BA} = \frac{1}{69.35\text{ in}}(-61\mathbf{i} + 33\mathbf{j})\text{in} = (-0.880\mathbf{i} + 0.476\mathbf{j})$$

$$\mathbf{e}_{BA} = (-0.880\mathbf{i} + 0.476\mathbf{j})$$

- To find the coordinates of point  $C$  we will write a vector from the origin to point  $C$ .

$$\mathbf{r}_C = \mathbf{r}_A + \mathbf{r}_{AC} = \mathbf{r}_A + s\mathbf{e}_{BA} = (75\mathbf{i} + 12\mathbf{j})\text{in} + (45\text{ in})(-0.880\mathbf{i} + 0.476\mathbf{j})$$

$$\mathbf{r}_C = (35.4\mathbf{i}) + 33.4\mathbf{j})\text{in}$$

Thus the coordinates of  $C$  are  $C(35.4, 33.4)$  in

**Problem 2.58** In Problem 2.57, determine the  $x$  and  $y$  coordinates of the collar  $C$  as functions of the distance  $s$ .

**Solution:** The coordinates of the point  $C$  are given by

$$x_C = x_B + s(-0.880) \text{ and } y_C = y_B + s(0.476).$$

Thus, the coordinates of point  $C$  are  $x_C = 75 - 0.880s$  in and  $y_C = 12 + 0.476s$  in. Note from the solution of Problem 2.57 above,  $0 \leq s \leq 69.4$  in.

**Problem 2.59** The position vector  $\mathbf{r}$  goes from point  $A$  to a point on the straight line between  $B$  and  $C$ . Its magnitude is  $|\mathbf{r}| = 6$  ft. Express  $\mathbf{r}$  in terms of scalar components.

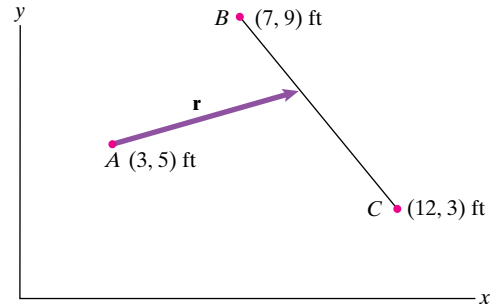

**Solution:** Determine the perpendicular vector to the line  $BC$  from point  $A$ , and then use this perpendicular to determine the angular orientation of the vector  $\mathbf{r}$ . The vectors are

$$\mathbf{r}_{AB} = (7 - 3)\mathbf{i} + (9 - 5)\mathbf{j} = 4\mathbf{i} + 4\mathbf{j}, \quad |\mathbf{r}_{AB}| = 5.6568$$

$$\mathbf{r}_{AC} = (12 - 3)\mathbf{i} + (3 - 5)\mathbf{j} = 9\mathbf{i} - 2\mathbf{j}, \quad |\mathbf{r}_{AC}| = 9.2195$$

$$\mathbf{r}_{BC} = (12 - 7)\mathbf{i} + (3 - 9)\mathbf{j} = 5\mathbf{i} - 6\mathbf{j}, \quad |\mathbf{r}_{BC}| = 7.8102$$

The unit vector parallel to  $BC$  is

$$\mathbf{e}_{BC} = \frac{\mathbf{r}_{BC}}{|\mathbf{r}_{BC}|} = 0.6402\mathbf{i} - 0.7682\mathbf{j} = \mathbf{i} \cos 50.19^\circ - \mathbf{j} \sin 50.19^\circ.$$

Add  $\pm 90^\circ$  to the angle to find the two possible perpendicular vectors:

$$\mathbf{e}_{AP1} = \mathbf{i} \cos 140.19^\circ - \mathbf{j} \sin 140.19^\circ, \text{ or}$$

$$\mathbf{e}_{AP2} = \mathbf{i} \cos 39.8^\circ + \mathbf{j} \sin 39.8^\circ.$$

Choose the latter, since it points from  $A$  to the line.

Given the triangle defined by vertices  $A$ ,  $B$ ,  $C$ , then the magnitude of the perpendicular corresponds to the altitude when the base is the line  $BC$ . The altitude is given by  $h = \frac{2(\text{area})}{\text{base}}$ . From geometry, the area of a triangle with known sides is given by

$$\text{area} = \sqrt{s(s - |\mathbf{r}_{BC}|)(s - |\mathbf{r}_{AC}|)(s - |\mathbf{r}_{AB}|)},$$

where  $s$  is the semiperimeter,  $s = \frac{1}{2}(|\mathbf{r}_{AC}| + |\mathbf{r}_{AB}| + |\mathbf{r}_{BC}|)$ . Substituting values,  $s = 11.343$ , and  $\text{area} = 22.0$  and the magnitude of the perpendicular is  $|\mathbf{r}_{AP}| = \frac{2(22)}{7.8102} = 5.6333$ . The angle between the vector  $\mathbf{r}$  and the perpendicular  $\mathbf{r}_{AP}$  is  $\beta = \cos^{-1} \frac{5.6333}{6} = 20.1^\circ$ . Thus the angle between the vector  $\mathbf{r}$  and the  $x$ -axis is  $\alpha = 39.8 \pm 20.1 = 59.1^\circ$  or  $19.7^\circ$ . The first angle is ruled out because it causes the vector  $\mathbf{r}$  to lie above the vector  $\mathbf{r}_{AB}$ , which is at a  $45^\circ$  angle relative to the  $x$ -axis. Thus:

$$\mathbf{r} = 6(\mathbf{i} \cos 19.7^\circ + \mathbf{j} \sin 19.7^\circ) = 5.65\mathbf{i} + 2.02\mathbf{j}$$

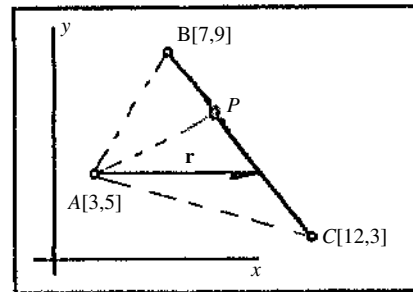

**Problem 2.60** Let  $\mathbf{r}$  be the position vector from point  $C$  to the point that is a distance  $s$  meters along the straight line between  $A$  and  $B$ . Express  $\mathbf{r}$  in terms of components. (Your answer will be in terms of  $s$ ).

**Solution:** First define the unit vector that points from  $A$  to  $B$ .

$$\mathbf{r}_{B/A} = ([10 - 3]\mathbf{i} + [9 - 4]\mathbf{j}) \text{ m} = (7\mathbf{i} + 5\mathbf{j}) \text{ m}$$

$$|\mathbf{r}_{B/A}| = \sqrt{(7 \text{ m})^2 + (5 \text{ m})^2} = \sqrt{74} \text{ m}$$

$$\mathbf{e}_{B/A} = \frac{1}{\sqrt{74}}(7\mathbf{i} + 5\mathbf{j})$$

Let  $P$  be the point that is a distance  $s$  along the line from  $A$  to  $B$ . The coordinates of point  $P$  are

$$x_p = 3 \text{ m} + s \left( \frac{7}{\sqrt{74}} \right) = (3 + 0.814s) \text{ m}$$

$$y_p = 4 \text{ m} + s \left( \frac{5}{\sqrt{74}} \right) = (4 + 0.581s) \text{ m}.$$

The vector  $\mathbf{r}$  that points from  $C$  to  $P$  is then

$$\mathbf{r} = ([3 + 0.814s - 9]\mathbf{i} + [4 + 0.581s - 3]\mathbf{j}) \text{ m}$$

$$\boxed{\mathbf{r} = ([0.814s - 6]\mathbf{i} + [0.581s + 1]\mathbf{j}) \text{ m}}$$

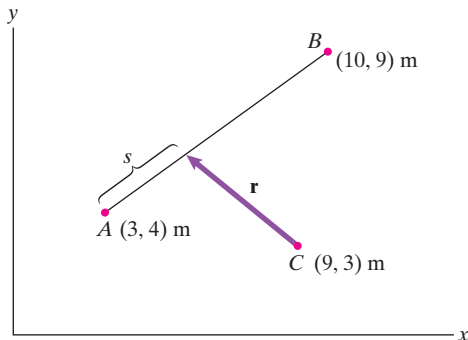

**Problem 2.61** A vector  $\mathbf{U} = 3\mathbf{i} - 4\mathbf{j} - 12\mathbf{k}$ . What is its magnitude?

**Strategy:** The magnitude of a vector is given in terms of its components by Eq. (2.14).

**Solution:** Use definition given in Eq. (14). The vector magnitude is

$$\boxed{|\mathbf{U}| = \sqrt{3^2 + (-4)^2 + (-12)^2} = 13}$$

**Problem 2.62** The vector  $\mathbf{e} = \frac{1}{3}\mathbf{i} + \frac{2}{3}\mathbf{j} + e_z\mathbf{k}$  is a unit vector. Determine the component  $e_z$ . (Notice that there are two answers.)

**Solution:**

$$\mathbf{e} = \frac{1}{3}\mathbf{i} + \frac{2}{3}\mathbf{j} + e_z\mathbf{k} \Rightarrow \left(\frac{1}{3}\right)^2 + \left(\frac{2}{3}\right)^2 + e_z^2 = 1 \Rightarrow e_z^2 = \frac{4}{9}$$

Thus

$$\boxed{e_z = \frac{2}{3} \quad \text{or} \quad e_z = -\frac{2}{3}}$$

**Problem 2.63** An engineer determines that an attachment point will be subjected to a force  $\mathbf{F} = 20\mathbf{i} + F_y\mathbf{j} - 45\mathbf{k}$  (kN). If the attachment point will safely support a force of 80-kN magnitude in any direction, what is the acceptable range of values for  $F_y$ ?

**Solution:**

$$80^2 \geq F_x^2 + F_y^2 + F_z^2$$

$$80^2 \geq 20^2 + F_y^2 + (45)^2$$

To find limits, use equality.

$$F_{y\text{LIMIT}}^2 = 80^2 - 20^2 - (45)^2$$

$$F_{y\text{LIMIT}}^2 = 3975$$

$$F_{y\text{LIMIT}} = +63.0, -63.0 \text{ (kN)}$$

$$|F_{y\text{LIMIT}}| \leq 63.0 \text{ kN} - 63.0 \text{ kN} \leq F_y \leq 63.0 \text{ kN}$$

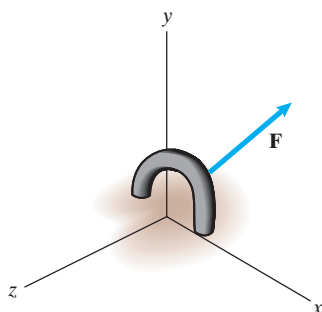

**Problem 2.64** A vector  $\mathbf{U} = U_x\mathbf{i} + U_y\mathbf{j} + U_z\mathbf{k}$ . Its magnitude is  $|\mathbf{U}| = 30$ . Its components are related by the equations  $U_y = -2U_x$  and  $U_z = 4U_y$ . Determine the components. (Notice that there are two answers.)

**Solution:** Substitute the relations between the components, determine the magnitude, and solve for the unknowns. Thus

$$\mathbf{U} = U_x\mathbf{i} + (-2U_x)\mathbf{j} + (4(-2U_x))\mathbf{k} = U_x(1\mathbf{i} - 2\mathbf{j} - 8\mathbf{k})$$

where  $U_x$  can be factored out since it is a scalar. Take the magnitude, noting that the absolute value of  $|U_x|$  must be taken:

$$30 = |U_x|\sqrt{1^2 + 2^2 + 8^2} = |U_x|(8.31).$$

Solving, we get  $|U_x| = 3.612$ , or  $U_x = \pm 3.61$ . The two possible vectors are

$$\mathbf{U} = +3.61\mathbf{i} + (-2(3.61))\mathbf{j} + (4(-2)(3.61))\mathbf{k}$$

$$= 3.61\mathbf{i} - 7.22\mathbf{j} - 28.9\mathbf{k}$$

$$\mathbf{U} = -3.61\mathbf{i} + (-2(-3.61))\mathbf{j}$$

$$+ 4(-2)(-3.61)\mathbf{k} = -3.61\mathbf{i} + 7.22\mathbf{j} + 28.9\mathbf{k}$$

**Problem 2.65** An object is acted upon by two forces  $\mathbf{F}_1 = 20\mathbf{i} + 30\mathbf{j} - 24\mathbf{k}$  (kN) and  $\mathbf{F}_2 = -60\mathbf{i} + 20\mathbf{j} + 40\mathbf{k}$  (kN). What is the magnitude of the total force acting on the object?

**Solution:**

$$\mathbf{F}_1 = (20\mathbf{i} + 30\mathbf{j} - 24\mathbf{k}) \text{ kN}$$

$$\mathbf{F}_2 = (-60\mathbf{i} + 20\mathbf{j} + 40\mathbf{k}) \text{ kN}$$

$$\mathbf{F} = \mathbf{F}_1 + \mathbf{F}_2 = (-40\mathbf{i} + 50\mathbf{j} + 16\mathbf{k}) \text{ kN}$$

Thus

$$F = \sqrt{(-40 \text{ kN})^2 + (50 \text{ kN})^2 + (16 \text{ kN})^2} = 66 \text{ kN}$$

**Problem 2.66** Two vectors  $\mathbf{U} = 3\mathbf{i} - 2\mathbf{j} + 6\mathbf{k}$  and  $\mathbf{V} = 4\mathbf{i} + 12\mathbf{j} - 3\mathbf{k}$ .

- (a) Determine the magnitudes of  $\mathbf{U}$  and  $\mathbf{V}$ .  
 (b) Determine the magnitude of the vector  $3\mathbf{U} + 2\mathbf{V}$ .

**Solution:** The magnitudes:

(a)  $|\mathbf{U}| = \sqrt{3^2 + 2^2 + 6^2} = 7$  and  $|\mathbf{V}| = \sqrt{4^2 + 12^2 + 3^2} = 13$

The resultant vector

$$3\mathbf{U} + 2\mathbf{V} = (9 + 8)\mathbf{i} + (-6 + 24)\mathbf{j} + (18 - 6)\mathbf{k}$$

$$= 17\mathbf{i} + 18\mathbf{j} + 12\mathbf{k}$$

(b) The magnitude  $|3\mathbf{U} + 2\mathbf{V}| = \sqrt{17^2 + 18^2 + 12^2} = 27.51$



**Problem 2.67** In Active Example 2.6, suppose that you want to redesign the truss, changing the position of point  $D$  so that the magnitude of the vector  $\mathbf{r}_{CD}$  from point  $C$  to point  $D$  is 3 m. To accomplish this, let the coordinates of point  $D$  be  $(2, y_D, 1)$  m, and determine the value of  $y_D$  so that  $|\mathbf{r}_{CD}| = 3$  m. Draw a sketch of the truss with point  $D$  in its new position. What are the new direction cosines of  $\mathbf{r}_{CD}$ ?

**Solution:** The vector  $\mathbf{r}_{CD}$  and the magnitude  $|\mathbf{r}_{CD}|$  are

$$\mathbf{r}_{CD} = [(2 \text{ m} - 4 \text{ m})\mathbf{i} + [y_D - 0]\mathbf{j} + [1 \text{ m} - 0]\mathbf{k}] = (-2 \text{ m})\mathbf{i} + (y_D)\mathbf{j} + (1 \text{ m})\mathbf{k}$$

$$|\mathbf{r}_{CD}| = \sqrt{(-2 \text{ m})^2 + (y_D)^2 + (1 \text{ m})^2} = 3 \text{ m}$$

Solving we find  $y_{CD} = \sqrt{(3 \text{ m})^2 - (-2 \text{ m})^2 - (1 \text{ m})^2} = 2 \text{ m}$

$$y_{CD} = 2 \text{ m}$$

The new direction cosines of  $\mathbf{r}_{CD}$ .

$$\begin{aligned} \cos \theta_x &= -2/3 = -0.667 \\ \cos \theta_y &= 2/3 = 0.667 \\ \cos \theta_z &= 1/3 = 0.333 \end{aligned}$$

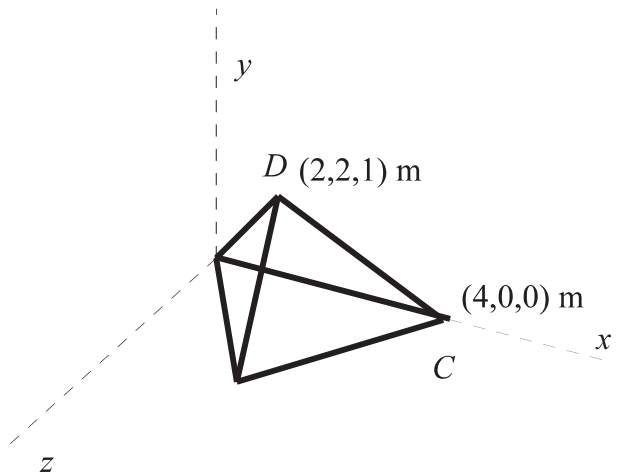
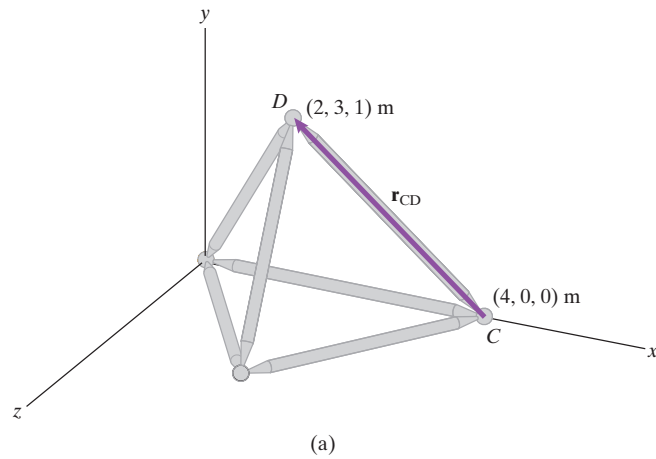

**Problem 2.68** A force vector is given in terms of its components by  $\mathbf{F} = 10\mathbf{i} - 20\mathbf{j} - 20\mathbf{k}$  (N).

- What are the direction cosines of  $\mathbf{F}$ ?
- Determine the components of a unit vector  $\mathbf{e}$  that has the same direction as  $\mathbf{F}$ .

**Solution:**

$$\mathbf{F} = (10\mathbf{i} - 20\mathbf{j} - 20\mathbf{k}) \text{ N}$$

$$F = \sqrt{(10 \text{ N})^2 + (-20 \text{ N})^2 + (-20 \text{ N})^2} = 30 \text{ N}$$

$$\begin{aligned} \cos \theta_x &= \frac{10 \text{ N}}{30 \text{ N}} = 0.333, & \cos \theta_y &= \frac{-20 \text{ N}}{30 \text{ N}} = -0.667, \\ \cos \theta_z &= \frac{-20 \text{ N}}{30 \text{ N}} = -0.667 \end{aligned}$$

$$\mathbf{e} = (0.333\mathbf{i} - 0.667\mathbf{j} - 0.667\mathbf{k})$$

**Problem 2.69** The cable exerts a force  $\mathbf{F}$  on the hook at  $O$  whose magnitude is 200 N. The angle between the vector  $\mathbf{F}$  and the  $x$  axis is  $40^\circ$ , and the angle between the vector  $\mathbf{F}$  and the  $y$  axis is  $70^\circ$ .

- (a) What is the angle between the vector  $\mathbf{F}$  and the  $z$  axis?  
 (b) Express  $\mathbf{F}$  in terms of components.

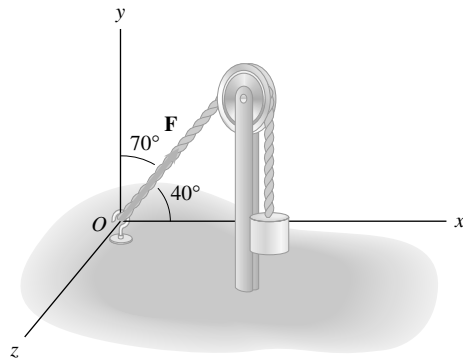

**Strategy:** (a) Because you know the angles between the vector  $\mathbf{F}$  and the  $x$  and  $y$  axes, you can use Eq. (2.16) to determine the angle between  $\mathbf{F}$  and the  $z$  axis. (Observe from the figure that the angle between  $\mathbf{F}$  and the  $z$  axis is clearly within the range  $0 < \theta_z < 180^\circ$ .) (b) The components of  $\mathbf{F}$  can be obtained with Eqs. (2.15).

**Solution:**

(a) 
$$(\cos 40^\circ)^2 + (\cos 70^\circ)^2 + (\cos \theta_z)^2 = 1 \Rightarrow \theta_z = 57.0^\circ$$

(b) 
$$\mathbf{F} = 200 \text{ N}(\cos 40^\circ \mathbf{i} + \cos 70^\circ \mathbf{j} + \cos 57.0^\circ \mathbf{k})$$
  

$$\mathbf{F} = (153.2\mathbf{i} + 68.4\mathbf{j} + 108.8\mathbf{k}) \text{ N}$$

**Problem 2.70** A unit vector has direction cosines  $\cos \theta_x = -0.5$  and  $\cos \theta_y = 0.2$ . Its  $z$  component is positive. Express it in terms of components.

**Solution:** Use Eq. (2.15) and (2.16). The third direction cosine is

$$\cos \theta_z = \pm \sqrt{1 - (0.5)^2 - (0.2)^2} = +0.8426.$$

The unit vector is

$$\mathbf{u} = -0.5\mathbf{i} + 0.2\mathbf{j} + 0.8426\mathbf{k}$$

**Problem 2.71** The airplane's engines exert a total thrust  $\mathbf{T}$  of 200-kN magnitude. The angle between  $\mathbf{T}$  and the  $x$  axis is  $120^\circ$ , and the angle between  $\mathbf{T}$  and the  $y$  axis is  $130^\circ$ . The  $z$  component of  $\mathbf{T}$  is positive.

- (a) What is the angle between  $\mathbf{T}$  and the  $z$  axis?  
 (b) Express  $\mathbf{T}$  in terms of components.

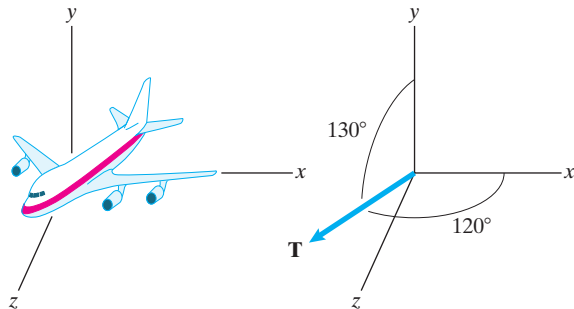

**Solution:** The  $x$ - and  $y$ -direction cosines are

$$l = \cos 120^\circ = -0.5, \quad m = \cos 130^\circ = -0.6428$$

from which the  $z$ -direction cosine is

$$n = \cos \theta_z = \pm \sqrt{1 - (0.5)^2 - (0.6428)^2} = +0.5804.$$

Thus the angle between  $\mathbf{T}$  and the  $z$ -axis is

(a) 
$$\theta_z = \cos^{-1}(0.5804) = 54.5^\circ$$
, and the thrust is

$$\mathbf{T} = 200(-0.5\mathbf{i} - 0.6428\mathbf{j} + 0.5804\mathbf{k}), \text{ or:}$$

(b) 
$$\mathbf{T} = -100\mathbf{i} - 128.6\mathbf{j} + 116.1\mathbf{k} \text{ (kN)}$$

**Problem 2.72** Determine the components of the position vector  $\mathbf{r}_{BD}$  from point  $B$  to point  $D$ . Use your result to determine the distance from  $B$  to  $D$ .

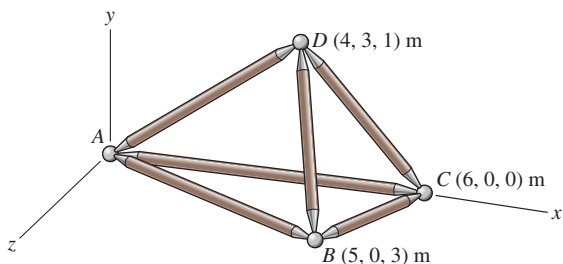

**Solution:** We have the following coordinates:  $A(0, 0, 0)$ ,  $B(5, 0, 3)$  m,  $C(6, 0, 0)$  m,  $D(4, 3, 1)$  m

$$\begin{aligned}\mathbf{r}_{BD} &= (4 \text{ m} - 5 \text{ m})\mathbf{i} + (3 \text{ m} - 0)\mathbf{j} + (1 \text{ m} - 3 \text{ m})\mathbf{k} \\ &= (-\mathbf{i} + 3\mathbf{j} - 2\mathbf{k}) \text{ m} \\ r_{BD} &= \sqrt{(-1 \text{ m})^2 + (3 \text{ m})^2 + (-2 \text{ m})^2} = 3.74 \text{ m}\end{aligned}$$

**Problem 2.73** What are the direction cosines of the position vector  $\mathbf{r}_{BD}$  from point  $B$  to point  $D$ ?

**Solution:**

$$\begin{aligned}\cos \theta_x &= \frac{-1 \text{ m}}{3.74 \text{ m}} = -0.267, & \cos \theta_y &= \frac{3 \text{ m}}{3.74 \text{ m}} = 0.802, \\ \cos \theta_z &= \frac{-2 \text{ m}}{3.74 \text{ m}} = 0.535\end{aligned}$$

**Problem 2.74** Determine the components of the unit vector  $\mathbf{e}_{CD}$  that points from point  $C$  toward point  $D$ .

**Solution:** We have the following coordinates:  $A(0, 0, 0)$ ,  $B(5, 0, 3)$  m,  $C(6, 0, 0)$  m,  $D(4, 3, 1)$  m

$$\mathbf{r}_{CD} = (4 \text{ m} - 6 \text{ m})\mathbf{i} + (3 \text{ m} - 0)\mathbf{j} + (1 \text{ m} - 0)\mathbf{k} = (-2\mathbf{i} + 3\mathbf{j} + 1\mathbf{k})$$

$$r_{CD} = \sqrt{(-2 \text{ m})^2 + (3 \text{ m})^2 + (1 \text{ m})^2} = 3.74 \text{ m}$$

Thus

$$\mathbf{e}_{CD} = \frac{1}{3.74 \text{ m}}(-2\mathbf{i} + 3\mathbf{j} + \mathbf{k}) \text{ m} = (-0.535\mathbf{i} + 0.802\mathbf{j} + 0.267\mathbf{k})$$

**Problem 2.75** What are the direction cosines of the unit vector  $\mathbf{e}_{CD}$  that points from point  $C$  toward point  $D$ ?

**Solution:** Using Problem 2.74

$$\cos \theta_x = -0.535, \quad \cos \theta_y = 0.802, \quad \cos \theta_z = 0.267$$

**Problem 2.76** In Example 2.7, suppose that the caisson shifts on the ground to a new position. The magnitude of the force  $\mathbf{F}$  remains 600 lb. In the new position, the angle between the force  $\mathbf{F}$  and the  $x$  axis is  $60^\circ$  and the angle between  $\mathbf{F}$  and the  $z$  axis is  $70^\circ$ . Express  $\mathbf{F}$  in terms of components.

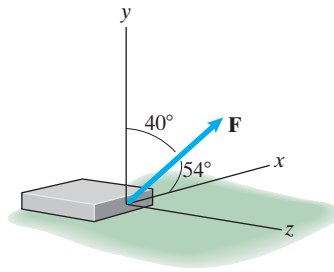

**Solution:** We need to find the angle  $\theta_y$  between the force  $\mathbf{F}$  and the  $y$  axis. We know that

$$\cos^2 \theta_x + \cos^2 \theta_y + \cos^2 \theta_z = 1$$

$$\cos \theta_y = \pm \sqrt{1 - \cos^2 \theta_x - \cos^2 \theta_z} = \pm \sqrt{1 - \cos^2 60^\circ - \cos^2 70^\circ} = \pm 0.7956$$

$$\theta_y = \pm \cos^{-1}(0.7956) = 37.3^\circ \text{ or } 142.7^\circ$$

We will choose  $\theta_y = 37.3^\circ$  because the picture shows the force pointing up. Now

$$F_x = (600 \text{ lb}) \cos 60^\circ = 300 \text{ lb}$$

$$F_y = (600 \text{ lb}) \cos 37.3^\circ = 477 \text{ lb}$$

$$F_z = (600 \text{ lb}) \cos 70^\circ = 205 \text{ lb}$$

$$\text{Thus } \mathbf{F} = (300\mathbf{i} + 477\mathbf{j} + 205\mathbf{k}) \text{ lb}$$

**Problem 2.77** Astronauts on the space shuttle use radar to determine the magnitudes and direction cosines of the position vectors of two satellites  $A$  and  $B$ . The vector  $\mathbf{r}_A$  from the shuttle to satellite  $A$  has magnitude 2 km, and direction cosines  $\cos \theta_x = 0.768$ ,  $\cos \theta_y = 0.384$ ,  $\cos \theta_z = 0.512$ . The vector  $\mathbf{r}_B$  from the shuttle to satellite  $B$  has magnitude 4 km and direction cosines  $\cos \theta_x = 0.743$ ,  $\cos \theta_y = 0.557$ ,  $\cos \theta_z = -0.371$ . What is the distance between the satellites?

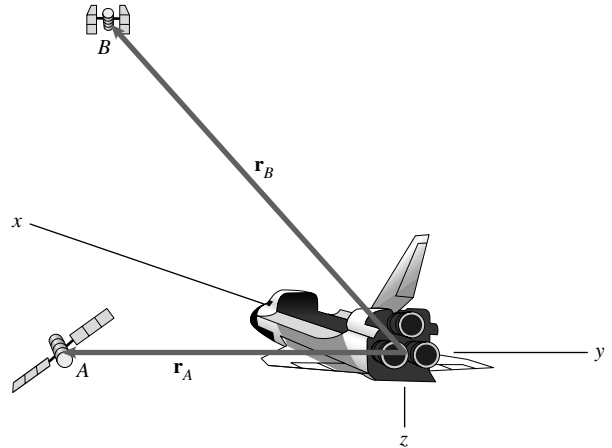

**Solution:** The two position vectors are:

$$\mathbf{r}_A = 2(0.768\mathbf{i} + 0.384\mathbf{j} + 0.512\mathbf{k}) = 1.536\mathbf{i} + 0.768\mathbf{j} + 1.024\mathbf{k} \text{ (km)}$$

$$\mathbf{r}_B = 4(0.743\mathbf{i} + 0.557\mathbf{j} - 0.371\mathbf{k}) = 2.972\mathbf{i} + 2.228\mathbf{j} - 1.484\mathbf{k} \text{ (km)}$$

The distance is the magnitude of the difference:

$$|\mathbf{r}_A - \mathbf{r}_B| = \sqrt{(1.536 - 2.972)^2 + (0.768 - 2.228)^2 + (1.024 - (-1.484))^2}$$

$$= 3.24 \text{ (km)}$$

**Problem 2.78** Archaeologists measure a pre-Columbian ceremonial structure and obtain the dimensions shown. Determine (a) the magnitude and (b) the direction cosines of the position vector from point  $A$  to point  $B$ .

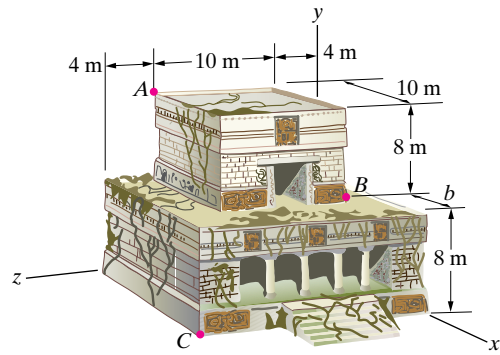

**Solution:**

(a) The coordinates are  $A(0, 16, 14)$  m and  $B(10, 8, 4)$  m.

$$\mathbf{r}_{AB} = ([10 - 0]\mathbf{i} + [8 - 16]\mathbf{j} + [4 - 14]\mathbf{k}) \text{ m} = (10\mathbf{i} - 8\mathbf{j} - 10\mathbf{k}) \text{ m}$$

$$|\mathbf{r}_{AB}| = \sqrt{10^2 + 8^2 + 10^2} \text{ m} = \sqrt{264} \text{ m} = 16.2 \text{ m}$$

$$|\mathbf{r}_{AB}| = 16.2 \text{ m}$$

(b)

$$\cos \theta_x = \frac{10}{\sqrt{264}} = 0.615$$

$$\cos \theta_y = \frac{-8}{\sqrt{264}} = -0.492$$

$$\cos \theta_z = \frac{-10}{\sqrt{264}} = -0.615$$

**Problem 2.79** Consider the structure described in Problem 2.78. After returning to the United States, an archaeologist discovers that a graduate student has erased the only data file containing the dimension  $b$ . But from recorded GPS data he is able to calculate that the distance from point  $B$  to point  $C$  is 16.61 m.

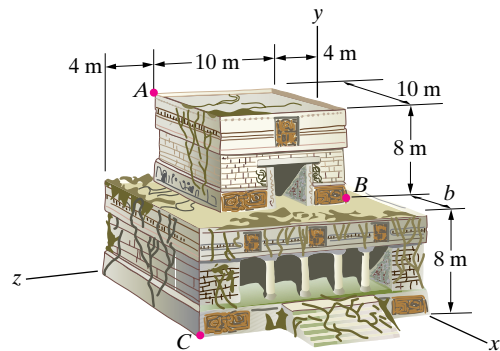

(a) What is the distance  $b$ ?  
 (b) Determine the direction cosines of the position vector from  $B$  to  $C$ .

**Solution:** We have the coordinates  $B(10 \text{ m}, 8 \text{ m}, 4 \text{ m})$ ,  $C(10 \text{ m} + b, 0, 18 \text{ m})$ .

$$\mathbf{r}_{BC} = (10 \text{ m} + b - 10 \text{ m})\mathbf{i} + (0 - 8 \text{ m})\mathbf{j} + (18 \text{ m} - 4 \text{ m})\mathbf{k}$$

$$\mathbf{r}_{BC} = (b)\mathbf{i} + (-8 \text{ m})\mathbf{j} + (14 \text{ m})\mathbf{k}$$

(a) We have  $(16.61 \text{ m})^2 = b^2 + (-8 \text{ m})^2 + (14 \text{ m})^2 \Rightarrow b = 3.99 \text{ m}$

(b) The direction cosines of  $\mathbf{r}_{BC}$  are

$$\cos \theta_x = \frac{3.99 \text{ m}}{16.61 \text{ m}} = 0.240$$

$$\cos \theta_y = \frac{-8 \text{ m}}{16.61 \text{ m}} = -0.482$$

$$\cos \theta_z = \frac{14 \text{ m}}{16.61 \text{ m}} = 0.843$$

**Problem 2.80** Observers at  $A$  and  $B$  use theodolites to measure the direction from their positions to a rocket in flight. If the coordinates of the rocket's position at a given instant are  $(4, 4, 2)$  km, determine the direction cosines of the vectors  $\mathbf{r}_{AR}$  and  $\mathbf{r}_{BR}$  that the observers would measure at that instant.

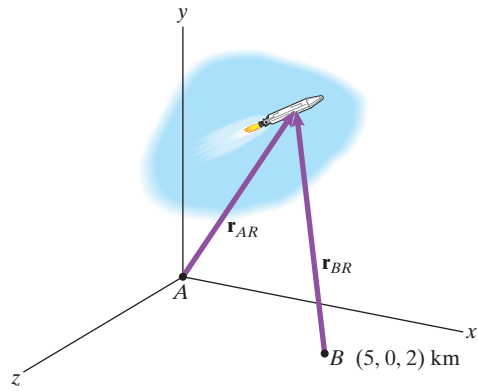

**Solution:** The vector  $\mathbf{r}_{AR}$  is given by

$$\mathbf{r}_{AR} = 4\mathbf{i} + 4\mathbf{j} + 2\mathbf{k} \text{ km}$$

and the magnitude of  $\mathbf{r}_{AR}$  is given by

$$|\mathbf{r}_{AR}| = \sqrt{(4)^2 + (4)^2 + (2)^2} \text{ km} = 6 \text{ km.}$$

The unit vector along  $AR$  is given by

$$\mathbf{u}_{AR} = \mathbf{r}_{AR}/|\mathbf{r}_{AR}|.$$

Thus,  $\mathbf{u}_{AR} = 0.667\mathbf{i} + 0.667\mathbf{j} + 0.333\mathbf{k}$

and the direction cosines are

$$\cos \theta_x = 0.667, \cos \theta_y = 0.667, \text{ and } \cos \theta_z = 0.333.$$

The vector  $\mathbf{r}_{BR}$  is given by

$$\mathbf{r}_{BR} = (x_R - x_B)\mathbf{i} + (y_R - y_B)\mathbf{j} + (z_R - z_B)\mathbf{k} \text{ km}$$

$$= (4 - 5)\mathbf{i} + (4 - 0)\mathbf{j} + (2 - 2)\mathbf{k} \text{ km}$$

and the magnitude of  $\mathbf{r}_{BR}$  is given by

$$|\mathbf{r}_{BR}| = \sqrt{(1)^2 + (4)^2 + (0)^2} \text{ km} = 4.12 \text{ km.}$$

The unit vector along  $BR$  is given by

$$\mathbf{e}_{BR} = \mathbf{r}_{BR}/|\mathbf{r}_{BR}|.$$

Thus,  $\mathbf{u}_{BR} = -0.242\mathbf{i} + 0.970\mathbf{j} + 0\mathbf{k}$

and the direction cosines are

$$\cos \theta_x = -0.242, \cos \theta_y = 0.970, \text{ and } \cos \theta_z = 0.0.$$

**Problem 2.81** In Problem 2.80, suppose that the coordinates of the rocket's position are unknown. At a given instant, the person at  $A$  determines that the direction cosines of  $\mathbf{r}_{AR}$  are  $\cos \theta_x = 0.535$ ,  $\cos \theta_y = 0.802$ , and  $\cos \theta_z = 0.267$ , and the person at  $B$  determines that the direction cosines of  $\mathbf{r}_{BR}$  are  $\cos \theta_x = -0.576$ ,  $\cos \theta_y = 0.798$ , and  $\cos \theta_z = -0.177$ . What are the coordinates of the rocket's position at that instant.

**Solution:** The vector from  $A$  to  $B$  is given by

$$\mathbf{r}_{AB} = (x_B - x_A)\mathbf{i} + (y_B - y_A)\mathbf{j} + (z_B - z_A)\mathbf{k} \text{ or}$$

$$\mathbf{r}_{AB} = (5 - 0)\mathbf{i} + (0 - 0)\mathbf{j} + (2 - 0)\mathbf{k} = 5\mathbf{i} + 2\mathbf{k} \text{ km.}$$

The magnitude of  $\mathbf{r}_{AB}$  is given by  $|\mathbf{r}_{AB}| = \sqrt{(5)^2 + (2)^2} = 5.39$  km. The unit vector along  $AB$ ,  $\mathbf{u}_{AB}$ , is given by

$$\mathbf{u}_{AB} = \mathbf{r}_{AB}/|\mathbf{r}_{AB}| = 0.928\mathbf{i} + 0\mathbf{j} + 0.371\mathbf{k} \text{ km.}$$

The unit vector along the line  $AR$ ,

$$\mathbf{u}_{AR} = \cos \theta_x \mathbf{i} + \cos \theta_y \mathbf{j} + \cos \theta_z \mathbf{k} = 0.535\mathbf{i} + 0.802\mathbf{j} + 0.267\mathbf{k}.$$

Similarly, the vector along  $BR$ ,  $\mathbf{u}_{BR} = -0.576\mathbf{i} + 0.798\mathbf{j} - 0.177\mathbf{k}$ . From the diagram in the problem statement, we see that  $\mathbf{r}_{AR} = \mathbf{r}_{AB} + \mathbf{r}_{BR}$ . Using the unit vectors, the vectors  $\mathbf{r}_{AR}$  and  $\mathbf{r}_{BR}$  can be written as

$$\mathbf{r}_{AR} = 0.535r_{AR}\mathbf{i} + 0.802r_{AR}\mathbf{j} + 0.267r_{AR}\mathbf{k}, \text{ and}$$

$$\mathbf{r}_{BR} = -0.576r_{BR}\mathbf{i} + 0.798r_{BR}\mathbf{j} - 0.177r_{BR}\mathbf{k}.$$

Substituting into the vector addition  $\mathbf{r}_{AR} = \mathbf{r}_{AB} + \mathbf{r}_{BR}$  and equating components, we get, in the  $x$  direction,  $0.535r_{AR} = -0.576r_{BR}$ , and in the  $y$  direction,  $0.802r_{AR} = 0.798r_{BR}$ . Solving, we get that  $r_{AR} = 4.489$  km. Calculating the components, we get

$$\mathbf{r}_{AR} = r_{AR}\mathbf{u}_{AR} = 0.535(4.489)\mathbf{i} + 0.802(4.489)\mathbf{j} + 0.267(4.489)\mathbf{k}.$$

Hence, the coordinates of the rocket,  $R$ , are (2.40, 3.60, 1.20) km.

**Problem 2.82\*** The height of Mount Everest was originally measured by a surveyor in the following way. He first measured the altitudes of two points and the horizontal distance between them. For example, suppose that the points  $A$  and  $B$  are 3000 m above sea level and are 10,000 m apart. He then used a theodolite to measure the direction cosines of the vector  $\mathbf{r}_{AP}$  from point  $A$  to the top of the mountain  $P$  and the vector  $\mathbf{r}_{BP}$  from point  $B$  to  $P$ . Suppose that the direction cosines of  $\mathbf{r}_{AP}$  are  $\cos \theta_x = 0.5179$ ,  $\cos \theta_y = 0.6906$ , and  $\cos \theta_z = 0.5048$ , and the direction cosines of  $\mathbf{r}_{BP}$  are  $\cos \theta_x = -0.3743$ ,  $\cos \theta_y = 0.7486$ , and  $\cos \theta_z = 0.5472$ . Using this data, determine the height of Mount Everest above sea level.

**Solution:** We have the following coordinates  $A(0, 0, 3000)$  m,  $B(10, 000, 0, 3000)$  m,  $P(x, y, z)$

Then

$$\mathbf{r}_{AP} = x\mathbf{i} + y\mathbf{j} + (z - 3000 \text{ m})\mathbf{k} = r_{AP}(0.5179\mathbf{i} + 0.6906\mathbf{j} + 0.5048\mathbf{k})$$

$$\mathbf{r}_{BP} = (x - 10,000 \text{ m})\mathbf{i} + y\mathbf{j} + (z - 3000 \text{ m})\mathbf{k}$$

$$= r_{BP}(-0.3743\mathbf{i} + 0.7486\mathbf{j} + 0.5472\mathbf{k})$$

Equating components gives us five equations (one redundant) which we can solve for the five unknowns.

$$x = r_{AP}0.5179$$

$$y = r_{AP}0.6906$$

$$z - 3000 \text{ m} = r_{AP}0.5048 \quad \Rightarrow \quad \boxed{z = 8848 \text{ m}}$$

$$x - 10000 \text{ m} = -r_{BP} - 0.7486$$

$$y = r_{BP}0.5472$$

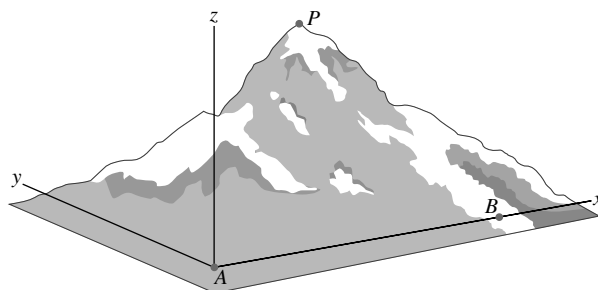

**Problem 2.83** The distance from point  $O$  to point  $A$  is 20 ft. The straight line  $AB$  is parallel to the  $y$  axis, and point  $B$  is in the  $x$ - $z$  plane. Express the vector  $\mathbf{r}_{OA}$  in terms of scalar components.

**Strategy:** You can resolve  $\mathbf{r}_{OA}$  into a vector from  $O$  to  $B$  and a vector from  $B$  to  $A$ . You can then resolve the vector from  $O$  to  $B$  into vector components parallel to the  $x$  and  $z$  axes. See Example 2.8.

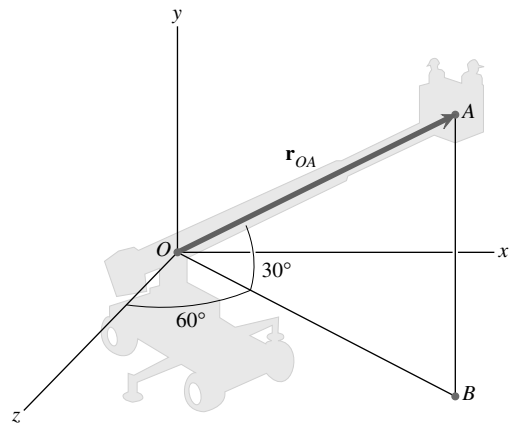

**Solution:** See Example 2.8. The length  $BA$  is, from the right triangle  $OAB$ ,

$$|r_{AB}| = |r_{OA}| \sin 30^\circ = 20(0.5) = 10 \text{ ft.}$$

Similarly, the length  $OB$  is

$$|r_{OB}| = |r_{OA}| \cos 30^\circ = 20(0.866) = 17.32 \text{ ft}$$

The vector  $\mathbf{r}_{OB}$  can be resolved into components along the axes by the right triangles  $OBP$  and  $OBQ$  and the condition that it lies in the  $x$ - $z$  plane.

Hence,

$$\mathbf{r}_{OB} = |r_{OB}|(\mathbf{i} \cos 30^\circ + \mathbf{j} \cos 90^\circ + \mathbf{k} \cos 60^\circ) \text{ or}$$

$$\mathbf{r}_{OB} = 15\mathbf{i} + 0\mathbf{j} + 8.66\mathbf{k}.$$

The vector  $\mathbf{r}_{BA}$  can be resolved into components from the condition that it is parallel to the  $y$ -axis. This vector is

$$\mathbf{r}_{BA} = |r_{BA}|(\mathbf{i} \cos 90^\circ + \mathbf{j} \cos 0^\circ + \mathbf{k} \cos 90^\circ) = 0\mathbf{i} + 10\mathbf{j} + 0\mathbf{k}.$$

The vector  $\mathbf{r}_{OA}$  is given by  $\mathbf{r}_{OA} = \mathbf{r}_{OB} + \mathbf{r}_{BA}$ , from which

$$\mathbf{r}_{OA} = 15\mathbf{i} + 10\mathbf{j} + 8.66\mathbf{k} \text{ (ft)}$$

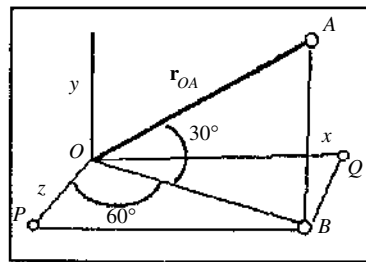

**Problem 2.84** The magnitudes of the two force vectors are  $|\mathbf{F}_A| = 140 \text{ lb}$  and  $|\mathbf{F}_B| = 100 \text{ lb}$ . Determine the magnitude of the sum of the forces  $\mathbf{F}_A + \mathbf{F}_B$ .

**Solution:** We have the vectors

$$\mathbf{F}_A = 140 \text{ lb}[\cos 40^\circ \sin 50^\circ \mathbf{i} + [\sin 40^\circ] \mathbf{j} + [\cos 40^\circ \cos 50^\circ] \mathbf{k}]$$

$$\mathbf{F}_A = (82.2\mathbf{i} + 90.0\mathbf{j} + 68.9\mathbf{k}) \text{ lb}$$

$$\mathbf{F}_B = 100 \text{ lb}[-\cos 60^\circ \sin 30^\circ \mathbf{i} + [\sin 60^\circ] \mathbf{j} + [\cos 60^\circ \cos 30^\circ] \mathbf{k}]$$

$$\mathbf{F}_B = (-25.0\mathbf{i} + 86.6\mathbf{j} + 43.3\mathbf{k}) \text{ lb}$$

Adding and taking the magnitude we have

$$\mathbf{F}_A + \mathbf{F}_B = (57.2\mathbf{i} + 176.6\mathbf{j} + 112.2\mathbf{k}) \text{ lb}$$

$$|\mathbf{F}_A + \mathbf{F}_B| = \sqrt{(57.2 \text{ lb})^2 + (176.6 \text{ lb})^2 + (112.2 \text{ lb})^2} = 217 \text{ lb}$$

$$|\mathbf{F}_A + \mathbf{F}_B| = 217 \text{ lb}$$

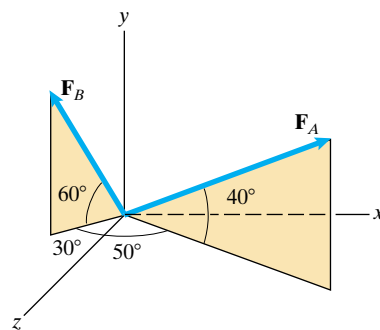



**Problem 2.85** Determine the direction cosines of the vectors  $\mathbf{F}_A$  and  $\mathbf{F}_B$ .

**Solution:** We have the vectors

$$\mathbf{F}_A = 140 \text{ lb}([\cos 40^\circ \sin 50^\circ]\mathbf{i} + [\sin 40^\circ]\mathbf{j} + [\cos 40^\circ \cos 50^\circ]\mathbf{k})$$

$$\mathbf{F}_A = (82.2\mathbf{i} + 90.0\mathbf{j} + 68.9\mathbf{k}) \text{ lb}$$

$$\mathbf{F}_B = 100 \text{ lb}([-\cos 60^\circ \sin 30^\circ]\mathbf{i} + [\sin 60^\circ]\mathbf{j} + [\cos 60^\circ \cos 30^\circ]\mathbf{k})$$

$$\mathbf{F}_B = (-25.0\mathbf{i} + 86.6\mathbf{j} + 43.3\mathbf{k}) \text{ lb}$$

The direction cosines for  $\mathbf{F}_A$  are

$$\cos \theta_x = \frac{82.2 \text{ lb}}{140 \text{ lb}} = 0.587, \cos \theta_y = \frac{90.0 \text{ lb}}{140 \text{ lb}} = 0.643,$$

$$\cos \theta_z = \frac{68.9 \text{ lb}}{140 \text{ lb}} = 0.492$$

The direction cosines for  $\mathbf{F}_B$  are

$$\cos \theta_x = \frac{-25.0 \text{ lb}}{100 \text{ lb}} = -0.250, \cos \theta_y = \frac{86.6 \text{ lb}}{100 \text{ lb}} = 0.866,$$

$$\cos \theta_z = \frac{43.3 \text{ lb}}{100 \text{ lb}} = 0.433$$

$$\mathbf{F}_A : \cos \theta_x = 0.587, \cos \theta_y = 0.643, \cos \theta_z = 0.492$$

$$\mathbf{F}_B : \cos \theta_x = -0.250, \cos \theta_y = 0.866, \cos \theta_z = 0.433$$

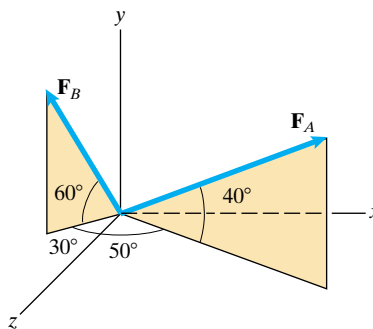

**Problem 2.86** In Example 2.8, suppose that a change in the wind causes a change in the position of the balloon and increases the magnitude of the force  $\mathbf{F}$  exerted on the hook at  $O$  to 900 N. In the new position, the angle between the vector component  $\mathbf{F}_h$  and  $\mathbf{F}$  is  $35^\circ$ , and the angle between the vector components  $\mathbf{F}_h$  and  $\mathbf{F}_z$  is  $40^\circ$ . Draw a sketch showing the relationship of these angles to the components of  $\mathbf{F}$ . Express  $\mathbf{F}$  in terms of its components.

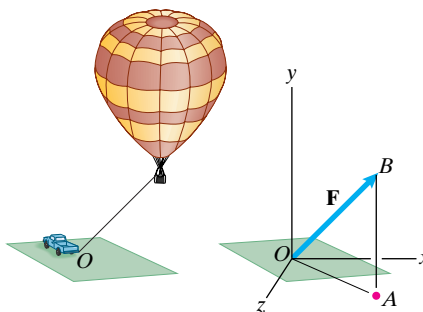

**Solution:** We have

$$|\mathbf{F}_y| = (900 \text{ N}) \sin 35^\circ = 516 \text{ N}$$

$$|\mathbf{F}_h| = (900 \text{ N}) \cos 35^\circ = 737 \text{ N}$$

$$|\mathbf{F}_x| = |\mathbf{F}_h| \sin 40^\circ = 474 \text{ N}$$

$$|\mathbf{F}_z| = |\mathbf{F}_h| \cos 40^\circ = 565 \text{ N}$$

Thus

$$\mathbf{F} = (474\mathbf{i} + 516\mathbf{j} + 565\mathbf{k}) \text{ N}$$

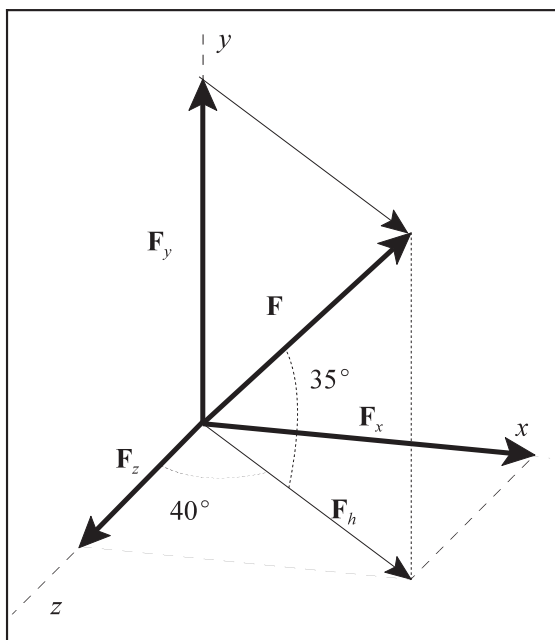

**Problem 2.87** An engineer calculates that the magnitude of the axial force in one of the beams of a geodesic dome is  $|\mathbf{P}| = 7.65$  kN. The cartesian coordinates of the endpoints  $A$  and  $B$  of the straight beam are  $(-12.4, 22.0, -18.4)$  m and  $(-9.2, 24.4, -15.6)$  m, respectively. Express the force  $\mathbf{P}$  in terms of scalar components.

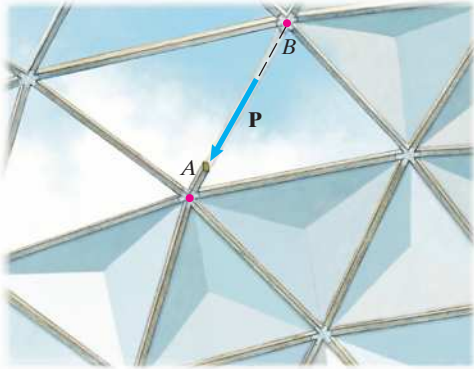

**Solution:** The components of the position vector from  $B$  to  $A$  are

$$\begin{aligned} \mathbf{r}_{BA} &= (x_A - x_B)\mathbf{i} + (y_A - y_B)\mathbf{j} + (z_A - z_B)\mathbf{k} \\ &= (-12.4 + 9.2)\mathbf{i} + (22.0 - 24.4)\mathbf{j} \\ &\quad + (-18.4 + 15.6)\mathbf{k} \\ &= -3.2\mathbf{i} - 2.4\mathbf{j} - 2.8\mathbf{k} \text{ (m)}. \end{aligned}$$

Dividing this vector by its magnitude, we obtain a unit vector that points from  $B$  toward  $A$ :

$$\mathbf{e}_{BA} = -0.655\mathbf{i} - 0.492\mathbf{j} - 0.573\mathbf{k}.$$

Therefore

$$\begin{aligned} \mathbf{P} &= |\mathbf{P}|\mathbf{e}_{BA} \\ &= 7.65 \mathbf{e}_{BA} \\ &= -5.01\mathbf{i} - 3.76\mathbf{j} - 4.39\mathbf{k} \text{ (kN)}. \end{aligned}$$

**Problem 2.88** The cable  $BC$  exerts an 8-kN force  $\mathbf{F}$  on the bar  $AB$  at  $B$ .

- Determine the components of a unit vector that points from  $B$  toward point  $C$ .
- Express  $\mathbf{F}$  in terms of components.

**Solution:**

$$(a) \quad \mathbf{e}_{BC} = \frac{\mathbf{r}_{BC}}{|\mathbf{r}_{BC}|} = \frac{(x_C - x_B)\mathbf{i} + (y_C - y_B)\mathbf{j} + (z_C - z_B)\mathbf{k}}{\sqrt{(x_C - x_B)^2 + (y_C - y_B)^2 + (z_C - z_B)^2}}$$

$$\mathbf{e}_{BC} = \frac{-2\mathbf{i} - 6\mathbf{j} + 3\mathbf{k}}{\sqrt{2^2 + 6^2 + 3^2}} = -\frac{2}{7}\mathbf{i} - \frac{6}{7}\mathbf{j} + \frac{3}{7}\mathbf{k}$$

$$\mathbf{e}_{BC} = -0.286\mathbf{i} - 0.857\mathbf{j} + 0.429\mathbf{k}$$

$$(b) \quad \mathbf{F} = |\mathbf{F}|\mathbf{e}_{BC} = 8\mathbf{e}_{BC} = -2.29\mathbf{i} - 6.86\mathbf{j} + 3.43\mathbf{k} \text{ (kN)}$$

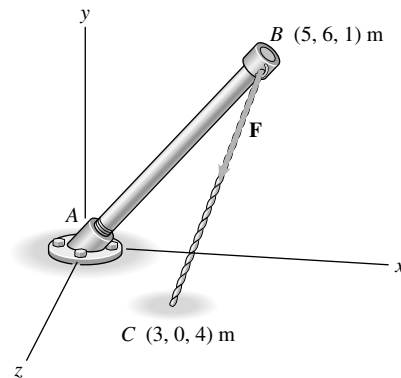

**Problem 2.89** A cable extends from point  $C$  to point  $E$ . It exerts a 50-lb force  $\mathbf{T}$  on plate  $C$  that is directed along the line from  $C$  to  $E$ . Express  $\mathbf{T}$  in terms of components.

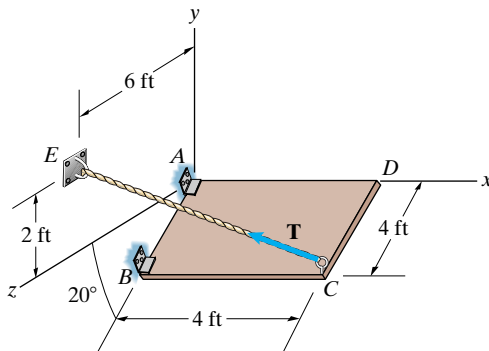

**Solution:** Find the unit vector  $\mathbf{e}_{CE}$  and multiply it times the magnitude of the force to get the vector in component form,

$$\mathbf{e}_{CE} = \frac{\mathbf{r}_{CE}}{|\mathbf{r}_{CE}|} = \frac{(x_E - x_C)\mathbf{i} + (y_E - y_C)\mathbf{j} + (z_E - z_C)\mathbf{k}}{\sqrt{(x_E - x_C)^2 + (y_E - y_C)^2 + (z_E - z_C)^2}}$$

The coordinates of point  $C$  are  $(4, -4 \sin 20^\circ, 4 \cos 20^\circ)$  or  $(4, -1.37, 3.76)$  (ft) The coordinates of point  $E$  are  $(0, 2, 6)$  (ft)

$$\mathbf{e}_{CE} = \frac{(0 - 4)\mathbf{i} + (2 - (-1.37))\mathbf{j} + (6 - 3.76)\mathbf{k}}{\sqrt{4^2 + 3.37^2 + 2.24^2}}$$

$$\mathbf{e}_{CE} = -0.703\mathbf{i} + 0.592\mathbf{j} + 0.394\mathbf{k}$$

$$\mathbf{T} = 50\mathbf{e}_{CE} \text{ (lb)}$$

$$\mathbf{T} = -35.2\mathbf{i} + 29.6\mathbf{j} + 19.7\mathbf{k} \text{ (lb)}$$

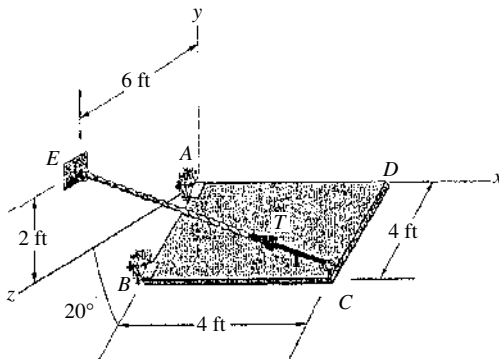

**Problem 2.90** In Example 2.9, suppose that the metal loop at  $A$  is moved upward so that the vertical distance to  $A$  increases from 7 ft to 8 ft. As a result, the magnitudes of the forces  $\mathbf{F}_{AB}$  and  $\mathbf{F}_{AC}$  increase to  $|\mathbf{F}_{AB}| = |\mathbf{F}_{AC}| = 240$  lb. What is the magnitude of the total force  $\mathbf{F} = \mathbf{F}_{AB} + \mathbf{F}_{AC}$  exerted on the loop by the rope?

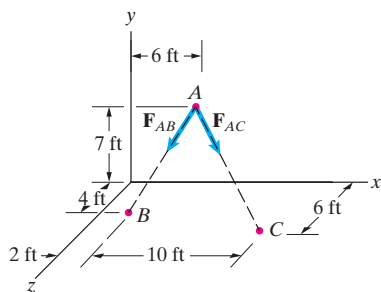
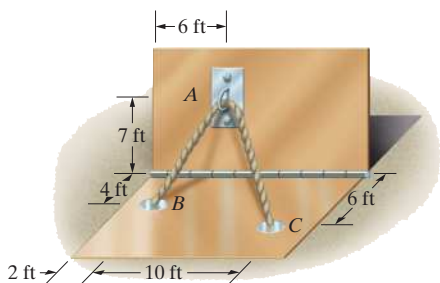

**Solution:** The new coordinates of point  $A$  are  $(6, 8, 0)$  ft. The position vectors are

$$\mathbf{r}_{AB} = (-4\mathbf{i} - 8\mathbf{j} + 4\mathbf{k}) \text{ ft}$$

$$\mathbf{r}_{AC} = (4\mathbf{i} - 8\mathbf{j} + 6\mathbf{k}) \text{ ft}$$

The forces are

$$\mathbf{F}_{AB} = (240 \text{ lb}) \frac{\mathbf{r}_{AB}}{|\mathbf{r}_{AB}|} = (-98.0\mathbf{i} - 196\mathbf{j} + 98.0\mathbf{k}) \text{ lb}$$

$$\mathbf{F}_{AC} = (240 \text{ lb}) \frac{\mathbf{r}_{AC}}{|\mathbf{r}_{AC}|} = (89.1\mathbf{i} - 178\mathbf{j} + 134.0\mathbf{k}) \text{ lb}$$

The sum of the forces is

$$\mathbf{F} = \mathbf{F}_{AB} + \mathbf{F}_{AC} = (-8.85\mathbf{i} - 374\mathbf{j} + 232\mathbf{k}) \text{ lb}$$

The magnitude is  $|\mathbf{F}| = 440$  lb

**Problem 2.91** The cable  $AB$  exerts a 200-lb force  $\mathbf{F}_{AB}$  at point  $A$  that is directed along the line from  $A$  to  $B$ . Express  $\mathbf{F}_{AB}$  in terms of components.

**Solution:** The coordinates of  $B$  are  $B(0,6,8)$ . The position vector from  $A$  to  $B$  is

$$\mathbf{r}_{AB} = (0 - 6)\mathbf{i} + (6 - 0)\mathbf{j} + (8 - 10)\mathbf{k} = -6\mathbf{i} + 6\mathbf{j} - 2\mathbf{k}$$

The magnitude is  $|\mathbf{r}_{AB}| = \sqrt{6^2 + 6^2 + 2^2} = 8.718$  ft.

The unit vector is

$$\mathbf{u}_{AB} = \frac{-6}{8.718}\mathbf{i} + \frac{6}{8.718}\mathbf{j} - \frac{2}{8.718}\mathbf{k}$$

or

$$\mathbf{u}_{AB} = -0.6882\mathbf{i} + 0.6882\mathbf{j} - 0.2294\mathbf{k}.$$

$$\mathbf{F}_{AB} = |\mathbf{F}_{AB}|\mathbf{u}_{AB} = 200(-0.6882\mathbf{i} + 0.6882\mathbf{j} - 0.2294\mathbf{k})$$

The components of the force are

$$\mathbf{F}_{AB} = |\mathbf{F}_{AB}|\mathbf{u}_{AB} = 200(-0.6882\mathbf{i} + 0.6882\mathbf{j} - 0.2294\mathbf{k}) \text{ or}$$

$$\boxed{\mathbf{F}_{AB} = -137.6\mathbf{i} + 137.6\mathbf{j} - 45.9\mathbf{k}}$$

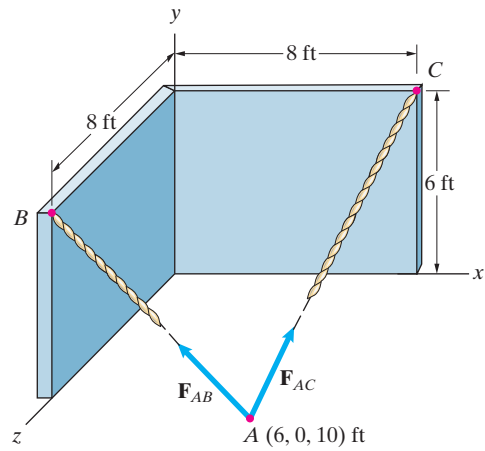

**Problem 2.92** Consider the cables and wall described in Problem 2.91. Cable  $AB$  exerts a 200-lb force  $\mathbf{F}_{AB}$  at point  $A$  that is directed along the line from  $A$  to  $B$ . The cable  $AC$  exerts a 100-lb force  $\mathbf{F}_{AC}$  at point  $A$  that is directed along the line from  $A$  to  $C$ . Determine the magnitude of the total force exerted at point  $A$  by the two cables.

**Solution:** Refer to the figure in Problem 2.91. From Problem 2.91 the force  $\mathbf{F}_{AB}$  is

$$\mathbf{F}_{AB} = -137.6\mathbf{i} + 137.6\mathbf{j} - 45.9\mathbf{k}$$

The coordinates of  $C$  are  $C(8,6,0)$ . The position vector from  $A$  to  $C$  is

$$\mathbf{r}_{AC} = (8 - 6)\mathbf{i} + (6 - 0)\mathbf{j} + (0 - 10)\mathbf{k} = 2\mathbf{i} + 6\mathbf{j} - 10\mathbf{k}.$$

The magnitude is  $|\mathbf{r}_{AC}| = \sqrt{2^2 + 6^2 + 10^2} = 11.83$  ft.

The unit vector is

$$\mathbf{u}_{AC} = \frac{2}{11.83}\mathbf{i} + \frac{6}{11.83}\mathbf{j} - \frac{10}{11.83}\mathbf{k} = 0.1691\mathbf{i} + 0.5072\mathbf{j} - 0.8453\mathbf{k}.$$

The force is

$$\mathbf{F}_{AC} = |\mathbf{F}_{AC}|\mathbf{u}_{AC} = 100\mathbf{u}_{AC} = 16.9\mathbf{i} + 50.7\mathbf{j} - 84.5\mathbf{k}.$$

The resultant of the two forces is

$$\begin{aligned} \mathbf{F}_R = \mathbf{F}_{AB} + \mathbf{F}_{AC} &= (-137.6 + 16.9)\mathbf{i} + (137.6 + 50.7)\mathbf{j} \\ &\quad + (-84.5 - 45.9)\mathbf{k}. \end{aligned}$$

$$\mathbf{F}_R = -120.7\mathbf{i} + 188.3\mathbf{j} - 130.4\mathbf{k}.$$

The magnitude is

$$\boxed{|\mathbf{F}_R| = \sqrt{120.7^2 + 188.3^2 + 130.4^2} = 259.0 \text{ lb}}$$

**Problem 2.93** The 70-m-tall tower is supported by three cables that exert forces  $\mathbf{F}_{AB}$ ,  $\mathbf{F}_{AC}$ , and  $\mathbf{F}_{AD}$  on it. The magnitude of each force is 2 kN. Express the total force exerted on the tower by the three cables in terms of components.

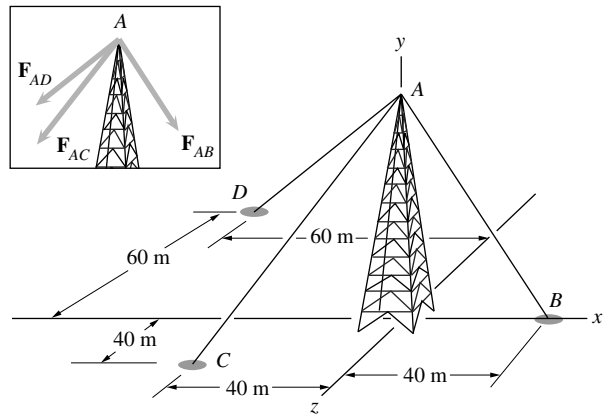

**Solution:** The coordinates of the points are  $A(0, 70, 0)$ ,  $B(40, 0, 0)$ ,  $C(-40, 0, 40)$ ,  $D(-60, 0, -60)$ .

The position vectors corresponding to the cables are:

$$\mathbf{r}_{AD} = (-60 - 0)\mathbf{i} + (0 - 70)\mathbf{j} + (-60 - 0)\mathbf{k}$$

$$\mathbf{r}_{AD} = -60\mathbf{i} - 70\mathbf{j} - 60\mathbf{k}$$

$$\mathbf{r}_{AC} = (-40 - 0)\mathbf{i} + (0 - 70)\mathbf{j} + (40 - 0)\mathbf{k}$$

$$\mathbf{r}_{AC} = -40\mathbf{i} - 70\mathbf{j} + 40\mathbf{k}$$

$$\mathbf{r}_{AB} = (40 - 0)\mathbf{i} + (0 - 70)\mathbf{j} + (0 - 0)\mathbf{k}$$

$$\mathbf{r}_{AB} = 40\mathbf{i} - 70\mathbf{j} + 0\mathbf{k}$$

The unit vectors corresponding to these position vectors are:

$$\mathbf{u}_{AD} = \frac{\mathbf{r}_{AD}}{|\mathbf{r}_{AD}|} = \frac{-60}{110}\mathbf{i} - \frac{70}{110}\mathbf{j} - \frac{60}{110}\mathbf{k}$$

$$= -0.5455\mathbf{i} - 0.6364\mathbf{j} - 0.5455\mathbf{k}$$

$$\mathbf{u}_{AC} = \frac{\mathbf{r}_{AC}}{|\mathbf{r}_{AC}|} = -\frac{40}{90}\mathbf{i} - \frac{70}{90}\mathbf{j} + \frac{40}{90}\mathbf{k}$$

$$= -0.4444\mathbf{i} - 0.7778\mathbf{j} + 0.4444\mathbf{k}$$

$$\mathbf{u}_{AB} = \frac{\mathbf{r}_{AB}}{|\mathbf{r}_{AB}|} = \frac{40}{80.6}\mathbf{i} - \frac{70}{80.6}\mathbf{j} + 0\mathbf{k} = 0.4963\mathbf{i} - 0.8685\mathbf{j} + 0\mathbf{k}$$

The forces are:

$$\mathbf{F}_{AB} = |\mathbf{F}_{AB}|\mathbf{u}_{AB} = 0.9926\mathbf{i} - 1.737\mathbf{j} + 0\mathbf{k}$$

$$\mathbf{F}_{AC} = |\mathbf{F}_{AC}|\mathbf{u}_{AC} = -0.8888\mathbf{i} - 1.5556\mathbf{j} + 0.8888\mathbf{k}$$

$$\mathbf{F}_{AD} = |\mathbf{F}_{AD}|\mathbf{u}_{AD} = -1.0910\mathbf{i} - 1.2728\mathbf{j} - 1.0910\mathbf{k}$$

The resultant force exerted on the tower by the cables is:

$$\mathbf{F}_R = \mathbf{F}_{AB} + \mathbf{F}_{AC} + \mathbf{F}_{AD} = -0.9875\mathbf{i} - 4.5648\mathbf{j} - 0.2020\mathbf{k} \text{ kN}$$

**Problem 2.94** Consider the tower described in Problem 2.93. The magnitude of the force  $\mathbf{F}_{AB}$  is 2 kN. The  $x$  and  $z$  components of the vector sum of the forces exerted on the tower by the three cables are zero. What are the magnitudes of  $\mathbf{F}_{AC}$  and  $\mathbf{F}_{AD}$ ?

**Solution:** From the solution of Problem 2.93, the unit vectors are:

$$\begin{aligned}\mathbf{u}_{AC} &= \frac{\mathbf{r}_{AC}}{|\mathbf{r}_{AC}|} = -\frac{40}{90}\mathbf{i} - \frac{70}{90}\mathbf{j} + \frac{40}{90}\mathbf{k} \\ &= -0.4444\mathbf{i} - 0.7778\mathbf{j} + 0.4444\mathbf{k}\end{aligned}$$

$$\begin{aligned}\mathbf{u}_{AD} &= \frac{\mathbf{r}_{AD}}{|\mathbf{r}_{AD}|} = \frac{-60}{110}\mathbf{i} - \frac{70}{110}\mathbf{j} - \frac{60}{110}\mathbf{k} \\ &= -0.5455\mathbf{i} - 0.6364\mathbf{j} - 0.5455\mathbf{k}\end{aligned}$$

From the solution of Problem 2.93 the force  $\mathbf{F}_{AB}$  is

$$\mathbf{F}_{AB} = |\mathbf{F}_{AB}|\mathbf{u}_{AB} = 0.9926\mathbf{i} - 1.737\mathbf{j} + 0\mathbf{k}$$

The forces  $\mathbf{F}_{AC}$  and  $\mathbf{F}_{AD}$  are:

$$\mathbf{F}_{AC} = |\mathbf{F}_{AC}|\mathbf{u}_{AC} = |\mathbf{F}_{AC}|(-0.4444\mathbf{i} - 0.7778\mathbf{j} + 0.4444\mathbf{k})$$

$$\mathbf{F}_{AD} = |\mathbf{F}_{AD}|\mathbf{u}_{AD} = |\mathbf{F}_{AD}|(-0.5455\mathbf{i} - 0.6364\mathbf{j} - 0.5455\mathbf{k})$$

Taking the sum of the forces:

$$\begin{aligned}\mathbf{F}_R &= \mathbf{F}_{AB} + \mathbf{F}_{AC} + \mathbf{F}_{AD} = (0.9926 - 0.4444|\mathbf{F}_{AC}| - 0.5455|\mathbf{F}_{AD}|)\mathbf{i} \\ &\quad + (-1.737 - 0.7778|\mathbf{F}_{AC}| - 0.6364|\mathbf{F}_{AD}|)\mathbf{j} \\ &\quad + (0.4444|\mathbf{F}_{AC}| - 0.5455|\mathbf{F}_{AD}|)\mathbf{k}\end{aligned}$$

The sum of the  $x$ - and  $z$ -components vanishes, hence the set of simultaneous equations:

$$0.4444|\mathbf{F}_{AC}| + 0.5455|\mathbf{F}_{AD}| = 0.9926 \text{ and}$$

$$0.4444|\mathbf{F}_{AC}| - 0.5455|\mathbf{F}_{AD}| = 0$$

These can be solved by means of standard algorithms, or by the use of commercial packages such as TK Solver Plus ® or Mathcad®. Here a hand held calculator was used to obtain the solution:

$$|\mathbf{F}_{AC}| = 1.1163 \text{ kN}$$

$$|\mathbf{F}_{AD}| = 0.9096 \text{ kN}$$

**Problem 2.95** In Example 2.10, suppose that the distance from point  $C$  to the collar  $A$  is increased from 0.2 m to 0.3 m, and the magnitude of the force  $\mathbf{T}$  increases to 60 N. Express  $\mathbf{T}$  in terms of its components.

**Solution:** The position vector from  $C$  to  $A$  is now

$$\mathbf{r}_{CA} = (0.3 \text{ m})\mathbf{e}_{CD} = (-0.137\mathbf{i} - 0.205\mathbf{j} + 0.171\mathbf{k})\text{m}$$

The position vector from the origin to  $A$  is

$$\mathbf{r}_{OA} = \mathbf{r}_{OC} + \mathbf{r}_{CA} = (0.4\mathbf{i} + 0.3\mathbf{j})\text{ m} + (-0.137\mathbf{i} - 0.205\mathbf{j} + 0.171\mathbf{k})\text{ m}$$

$$\mathbf{r}_{OA} = (0.263\mathbf{i} + 0.0949\mathbf{j} + 0.171\mathbf{k})\text{ m}$$

The coordinates of  $A$  are (0.263, 0.0949, 0.171) m.

The position vector from  $A$  to  $B$  is

$$\mathbf{r}_{AB} = ([0 - 0.263]\mathbf{i} + [0.5 - 0.0949]\mathbf{j} + [0.15 - 0.171]\mathbf{k})\text{ m}$$

$$\mathbf{r}_{AB} = (-0.263\mathbf{i} + 0.405\mathbf{j} - 0.209\mathbf{k})\text{ m}$$

The force  $\mathbf{T}$  is

$$\mathbf{T} = (60 \text{ N})\frac{\mathbf{r}_{AB}}{|\mathbf{r}_{AB}|} = (-32.7\mathbf{i} + 50.3\mathbf{j} - 2.60\mathbf{k})\text{ N}$$

$$\mathbf{T} = (-32.7\mathbf{i} + 50.3\mathbf{j} - 2.60\mathbf{k})\text{ N}$$

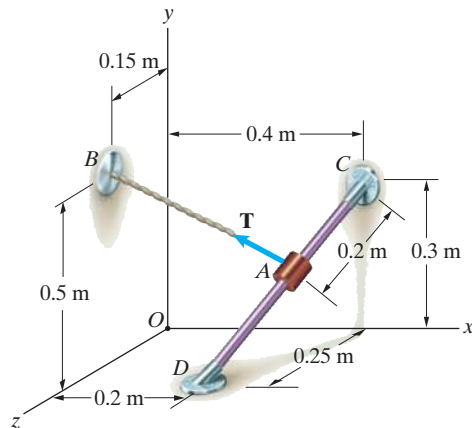

**Problem 2.96** The cable  $AB$  exerts a 32-lb force  $\mathbf{T}$  on the collar at  $A$ . Express  $\mathbf{T}$  in terms of components.

**Solution:** The coordinates of point  $B$  are  $B(0, 7, 4)$ . The vector position of  $B$  is  $\mathbf{r}_{OB} = 0\mathbf{i} + 7\mathbf{j} + 4\mathbf{k}$ .

The vector from point  $A$  to point  $B$  is given by

$$\mathbf{r}_{AB} = \mathbf{r}_{OB} - \mathbf{r}_{OA}$$

From Problem 2.95,  $\mathbf{r}_{OA} = 2.67\mathbf{i} + 2.33\mathbf{j} + 2.67\mathbf{k}$ . Thus

$$\mathbf{r}_{AB} = (0 - 2.67)\mathbf{i} + (7 - 2.33)\mathbf{j} + (4 - 2.67)\mathbf{k}$$

$$\mathbf{r}_{AB} = -2.67\mathbf{i} + 4.67\mathbf{j} + 1.33\mathbf{k}$$

The magnitude is

$$|\mathbf{r}_{AB}| = \sqrt{2.67^2 + 4.67^2 + 1.33^2} = 5.54 \text{ ft.}$$

The unit vector pointing from  $A$  to  $B$  is

$$\mathbf{u}_{AB} = \frac{\mathbf{r}_{AB}}{|\mathbf{r}_{AB}|} = -0.4819\mathbf{i} + 0.8429\mathbf{j} + 0.2401\mathbf{k}$$

The force  $\mathbf{T}$  is given by

$$\mathbf{T}_{AB} = |\mathbf{T}_{AB}|\mathbf{u}_{AB} = 32\mathbf{u}_{AB} = -15.4\mathbf{i} + 27.0\mathbf{j} + 7.7\mathbf{k} \text{ (lb)}$$

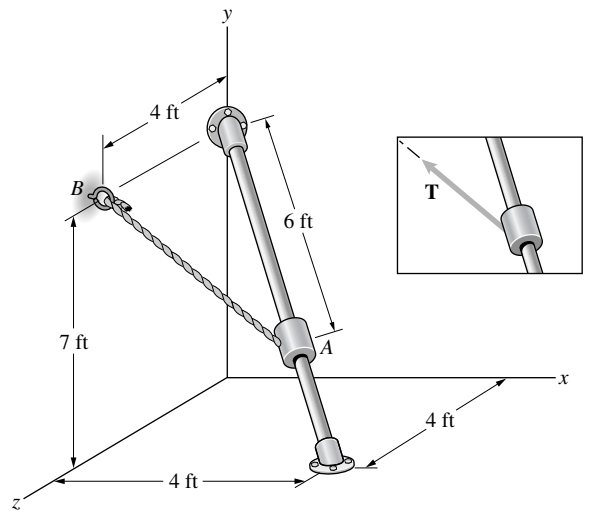

**Problem 2.97** The circular bar has a 4-m radius and lies in the  $x$ - $y$  plane. Express the position vector from point  $B$  to the collar at  $A$  in terms of components.

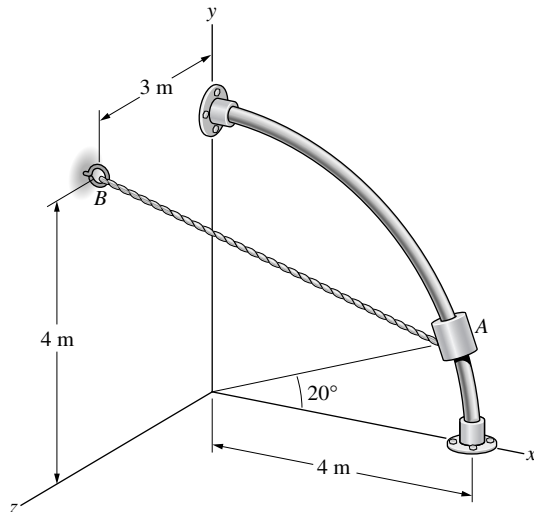

**Solution:** From the figure, the point  $B$  is at  $(0, 4, 3)$  m. The coordinates of point  $A$  are determined by the radius of the circular bar and the angle shown in the figure. The vector from the origin to  $A$  is  $\mathbf{r}_{OA} = 4 \cos(20^\circ)\mathbf{i} + 4 \sin(20^\circ)\mathbf{j}$  m. Thus, the coordinates of point  $A$  are  $(3.76, 1.37, 0)$  m. The vector from  $B$  to  $A$  is given by  $\mathbf{r}_{BA} = (x_A - x_B)\mathbf{i} + (y_A - y_B)\mathbf{j} + (z_A - z_B)\mathbf{k} = 3.76\mathbf{i} - 2.63\mathbf{j} - 3\mathbf{k}$  m. Finally, the scalar components of the vector from  $B$  to  $A$  are  $(3.76, -2.63, -3)$  m.

**Problem 2.98** The cable  $AB$  in Problem 2.97 exerts a 60-N force  $\mathbf{T}$  on the collar at  $A$  that is directed along the line from  $A$  toward  $B$ . Express  $\mathbf{T}$  in terms of components.

**Solution:** We know  $\mathbf{r}_{BA} = 3.76\mathbf{i} - 2.63\mathbf{j} - 3\mathbf{k}$  m from Problem 2.97. The unit vector  $\mathbf{u}_{AB} = -\mathbf{r}_{BA}/|\mathbf{r}_{BA}|$ . The unit vector is  $\mathbf{u}_{AB} = -0.686\mathbf{i} + 0.480\mathbf{j} + 0.547\mathbf{k}$ . Hence, the force vector  $\mathbf{T}$  is given by

$$\mathbf{T} = |\mathbf{T}|(-0.686\mathbf{i} + 0.480\mathbf{j} + 0.547\mathbf{k}) \text{ N} = -41.1\mathbf{i} + 28.8\mathbf{j} + 32.8\mathbf{k} \text{ N}$$

**Problem 2.99** In Active Example 2.11, suppose that the vector  $\mathbf{V}$  is changed to  $\mathbf{V} = 4\mathbf{i} - 6\mathbf{j} - 10\mathbf{k}$ .

- (a) What is the value of  $\mathbf{U} \cdot \mathbf{V}$ ?  
 (b) What is the angle between  $\mathbf{U}$  and  $\mathbf{V}$  when they are placed tail to tail?

**Solution:** From Active Example 2.4 we have the expression for  $\mathbf{U}$ . Thus

$$\mathbf{U} = 6\mathbf{i} - 5\mathbf{j} - 3\mathbf{k}, \mathbf{V} = 4\mathbf{i} - 6\mathbf{j} - 10\mathbf{k}$$

$$\mathbf{U} \cdot \mathbf{V} = (6)(4) + (-5)(-6) + (-3)(-10) = 84$$

$$\cos \theta = \frac{\mathbf{U} \cdot \mathbf{V}}{|\mathbf{U}||\mathbf{V}|} = \frac{84}{\sqrt{6^2 + (-5)^2 + (-3)^2} \sqrt{4^2 + (-6)^2 + (-10)^2}} = 0.814$$

$$\theta = \cos^{-1}(0.814) = 35.5^\circ$$

$$(a) \mathbf{U} \cdot \mathbf{V} = 84, (b) \theta = 35.5^\circ$$

**Problem 2.100** In Example 2.12, suppose that the coordinates of point  $B$  are changed to  $(6, 4, 4)$  m. What is the angle  $\theta$  between the lines  $AB$  and  $AC$ ?

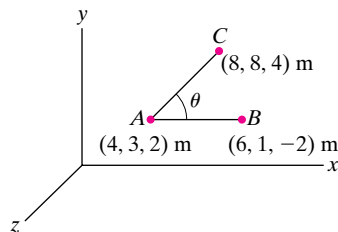

**Solution:** Using the new coordinates we have

$$\mathbf{r}_{AB} = (2\mathbf{i} + \mathbf{j} + 2\mathbf{k}) \text{ m}, |\mathbf{r}_{AB}| = 3 \text{ m}$$

$$\mathbf{r}_{AC} = (4\mathbf{i} + 5\mathbf{j} + 2\mathbf{k}) \text{ m}, |\mathbf{r}_{AC}| = 6.71 \text{ m}$$

$$\cos \theta = \frac{\mathbf{r}_{AB} \cdot \mathbf{r}_{AC}}{|\mathbf{r}_{AB}||\mathbf{r}_{AC}|} = \frac{(2)(4) + (1)(5) + (2)(2)}{(3 \text{ m})(6.71 \text{ m})} = 0.845$$

$$\theta = \cos^{-1}(0.845) = 32.4^\circ$$

$$\theta = 32.4^\circ$$

**Problem 2.101** What is the dot product of the position vector  $\mathbf{r} = -10\mathbf{i} + 25\mathbf{j}$  (m) and the force vector

$$\mathbf{F} = 300\mathbf{i} + 250\mathbf{j} + 300\mathbf{k} \text{ (N)}$$

**Solution:** Use Eq. (2.23).

$$\mathbf{F} \cdot \mathbf{r} = (300)(-10) + (250)(25) + (300)(0) = 3250 \text{ N}\cdot\text{m}$$

**Problem 2.102** Suppose that the dot product of two vectors  $\mathbf{U}$  and  $\mathbf{V}$  is  $\mathbf{U} \cdot \mathbf{V} = 0$ . If  $|\mathbf{U}| \neq 0$ , what do you know about the vector  $\mathbf{V}$ ?

**Solution:**

$$\text{Either } |\mathbf{V}| = 0 \text{ or } \mathbf{V} \perp \mathbf{U}$$



**Problem 2.103** Two *perpendicular* vectors are given in terms of their components by

$$\mathbf{U} = U_x \mathbf{i} - 4\mathbf{j} + 6\mathbf{k}$$

and  $\mathbf{V} = 3\mathbf{i} + 2\mathbf{j} - 3\mathbf{k}$ .

Use the dot product to determine the component  $U_x$ .

**Solution:** When the vectors are perpendicular,  $\mathbf{U} \cdot \mathbf{V} \equiv 0$ .

Thus

$$\begin{aligned} \mathbf{U} \cdot \mathbf{V} &= U_x V_x + U_y V_y + U_z V_z = 0 \\ &= 3U_x + (-4)(2) + (6)(-3) = 0 \end{aligned}$$

$$3U_x = 26$$

$$U_x = 8.67$$

**Problem 2.104** Three vectors

$$\mathbf{U} = U_x \mathbf{i} + 3\mathbf{j} + 2\mathbf{k}$$

$$\mathbf{V} = -3\mathbf{i} + V_y \mathbf{j} + 3\mathbf{k}$$

$$\mathbf{W} = -2\mathbf{i} + 4\mathbf{j} + W_z \mathbf{k}$$

are mutually perpendicular. Use the dot product to determine the components  $U_x$ ,  $V_y$ , and  $W_z$ .

**Solution:** For mutually perpendicular vectors, we have three equations, i.e.,

$$\mathbf{U} \cdot \mathbf{V} = 0$$

$$\mathbf{U} \cdot \mathbf{W} = 0$$

$$\mathbf{V} \cdot \mathbf{W} = 0$$

Thus

$$\left. \begin{aligned} -3U_x + 3V_y + 6 &= 0 \\ -2U_x + 12 + 2W_z &= 0 \\ +6 + 4V_y + 3W_z &= 0 \end{aligned} \right\} \begin{array}{l} 3 \text{ Eqns} \\ 3 \text{ Unknowns} \end{array}$$

Solving, we get

$U_x$	$= 2.857$
$V_y$	$= 0.857$
$W_z$	$= -3.143$

**Problem 2.105** The magnitudes  $|\mathbf{U}| = 10$  and  $|\mathbf{V}| = 20$ .

- Use the definition of the dot product to determine  $\mathbf{U} \cdot \mathbf{V}$ .
- Use Eq. (2.23) to obtain  $\mathbf{U} \cdot \mathbf{V}$ .

**Solution:**

- The definition of the dot product (Eq. (2.18)) is

$$\mathbf{U} \cdot \mathbf{V} = |\mathbf{U}||\mathbf{V}| \cos \theta. \text{ Thus}$$

$$\mathbf{U} \cdot \mathbf{V} = (10)(20) \cos(45^\circ - 30^\circ) = 193.2$$

- The components of  $\mathbf{U}$  and  $\mathbf{V}$  are

$$\mathbf{U} = 10(\mathbf{i} \cos 45^\circ + \mathbf{j} \sin 45^\circ) = 7.07\mathbf{i} + 7.07\mathbf{j}$$

$$\mathbf{V} = 20(\mathbf{i} \cos 30^\circ + \mathbf{j} \sin 30^\circ) = 17.32\mathbf{i} + 10\mathbf{j}$$

From Eq. (2.23)  $\mathbf{U} \cdot \mathbf{V} = (7.07)(17.32) + (7.07)(10) = 193.2$

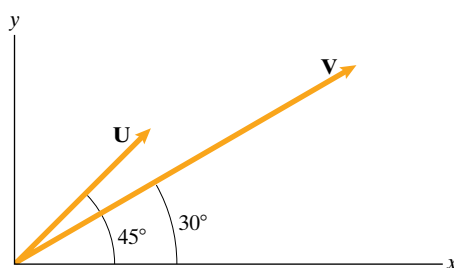

**Problem 2.106** By evaluating the dot product  $\mathbf{U} \cdot \mathbf{V}$ , prove the identity  $\cos(\theta_1 - \theta_2) = \cos \theta_1 \cos \theta_2 + \sin \theta_1 \sin \theta_2$ .

**Strategy:** Evaluate the dot product both by using Eq. (2.18) and by using Eq. (2.23).

**Solution:** The strategy is to use the definition Eq. (2.18) and the Eq. (2.23). From Eq. (2.18) and the figure,

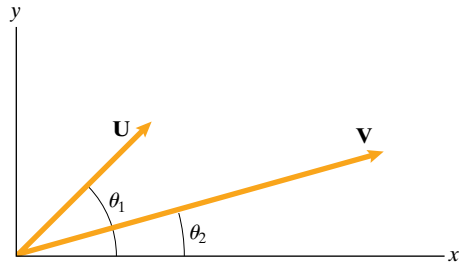

$\mathbf{U} \cdot \mathbf{V} = |\mathbf{U}||\mathbf{V}| \cos(\theta_1 - \theta_2)$ . From Eq. (2.23) and the figure,

$$\mathbf{U} = |\mathbf{U}|(\mathbf{i} \cos \theta_1 + \mathbf{j} \sin \theta_1), \quad \mathbf{V} = |\mathbf{V}|(\mathbf{i} \cos \theta_2 + \mathbf{j} \sin \theta_2),$$

and the dot product is  $\mathbf{U} \cdot \mathbf{V} = |\mathbf{U}||\mathbf{V}|(\cos \theta_1 \cos \theta_2 + \sin \theta_1 \sin \theta_2)$ .

Equating the two results:

$$\mathbf{U} \cdot \mathbf{V} = |\mathbf{U}||\mathbf{V}| \cos(\theta_1 - \theta_2) = |\mathbf{U}||\mathbf{V}|(\cos \theta_1 \cos \theta_2 + \sin \theta_1 \sin \theta_2),$$

from which if  $|\mathbf{U}| \neq 0$  and  $|\mathbf{V}| \neq 0$ , it follows that

$$\boxed{\cos(\theta_1 - \theta_2) = \cos \theta_1 \cos \theta_2 + \sin \theta_1 \sin \theta_2}, \quad \text{Q.E.D.}$$

**Problem 2.107** Use the dot product to determine the angle between the forestay (cable  $AB$ ) and the backstay (cable  $BC$ ).

**Solution:** The unit vector from  $B$  to  $A$  is

$$\mathbf{e}_{BA} = \frac{\mathbf{r}_{BA}}{|\mathbf{r}_{BA}|} = -0.321\mathbf{i} - 0.947\mathbf{j}$$

The unit vector from  $B$  to  $C$  is

$$\mathbf{e}_{BC} = \frac{\mathbf{r}_{BC}}{|\mathbf{r}_{BC}|} = 0.385\mathbf{i} - 0.923\mathbf{j}$$

From the definition of the dot product,  $\mathbf{e}_{BA} \cdot \mathbf{e}_{BC} = 1 \cdot 1 \cdot \cos \theta$ , where  $\theta$  is the angle between  $BA$  and  $BC$ . Thus

$$\cos \theta = (-0.321)(0.385) + (-0.947)(-0.923)$$

$$\cos \theta = 0.750$$

$$\theta = 41.3^\circ$$

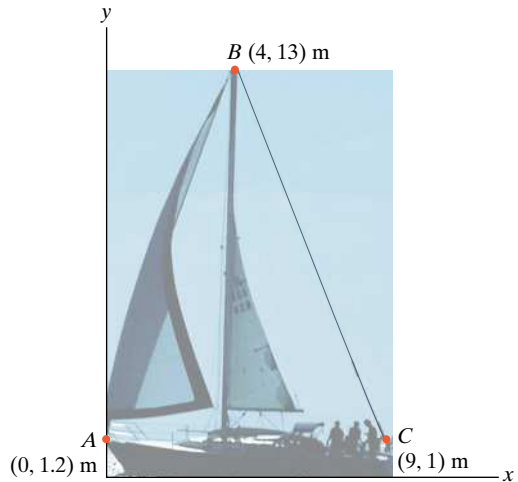

**Problem 2.108** Determine the angle  $\theta$  between the lines  $AB$  and  $AC$  (a) by using the law of cosines (see Appendix A); (b) by using the dot product.

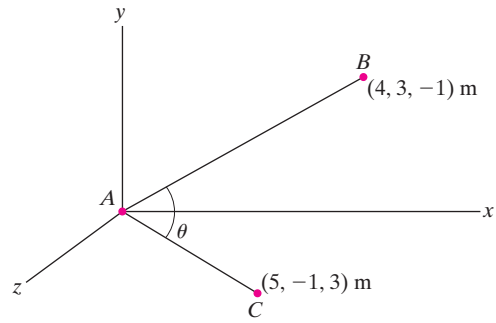

**Solution:**

(a) We have the distances:

$$AB = \sqrt{4^2 + 3^2 + 1^2} \text{ m} = \sqrt{26} \text{ m}$$

$$AC = \sqrt{5^2 + 1^2 + 3^2} \text{ m} = \sqrt{35} \text{ m}$$

$$BC = \sqrt{(5-4)^2 + (-1-3)^2 + (3+1)^2} \text{ m} = \sqrt{33} \text{ m}$$

The law of cosines gives

$$BC^2 = AB^2 + AC^2 - 2(AB)(AC) \cos \theta$$

$$\cos \theta = \frac{AB^2 + AC^2 - BC^2}{2(AB)(AC)} = 0.464 \Rightarrow \boxed{\theta = 62.3^\circ}$$

(b) Using the dot product

$$\mathbf{r}_{AB} = (4\mathbf{i} + 3\mathbf{j} - \mathbf{k}) \text{ m}, \quad \mathbf{r}_{AC} = (5\mathbf{i} - \mathbf{j} + 3\mathbf{k}) \text{ m}$$

$$\mathbf{r}_{AB} \cdot \mathbf{r}_{AC} = (4 \text{ m})(5 \text{ m}) + (3 \text{ m})(-1 \text{ m}) + (-1 \text{ m})(3 \text{ m}) = 14 \text{ m}^2$$

$$\mathbf{r}_{AB} \cdot \mathbf{r}_{AC} = (AB)(AC) \cos \theta$$

Therefore

$$\boxed{\cos \theta = \frac{14 \text{ m}^2}{\sqrt{26} \text{ m} \sqrt{35} \text{ m}} = 0.464 \Rightarrow \theta = 62.3^\circ}$$

**Problem 2.109** The ship  $O$  measures the positions of the ship  $A$  and the airplane  $B$  and obtains the coordinates shown. What is the angle  $\theta$  between the lines of sight  $OA$  and  $OB$ ?

**Solution:** From the coordinates, the position vectors are:

$$\mathbf{r}_{OA} = 6\mathbf{i} + 0\mathbf{j} + 3\mathbf{k} \text{ and } \mathbf{r}_{OB} = 4\mathbf{i} + 4\mathbf{j} - 4\mathbf{k}$$

$$\text{The dot product: } \mathbf{r}_{OA} \cdot \mathbf{r}_{OB} = (6)(4) + (0)(4) + (3)(-4) = 12$$

$$\text{The magnitudes: } |\mathbf{r}_{OA}| = \sqrt{6^2 + 0^2 + 3^2} = 6.71 \text{ km and}$$

$$|\mathbf{r}_{OB}| = \sqrt{4^2 + 4^2 + 4^2} = 6.93 \text{ km.}$$

$$\text{From Eq. (2.24) } \cos \theta = \frac{\mathbf{r}_{OA} \cdot \mathbf{r}_{OB}}{|\mathbf{r}_{OA}| |\mathbf{r}_{OB}|} = 0.2581, \text{ from which } \theta = \pm 75^\circ.$$

From the problem and the construction, only the positive angle makes sense, hence  $\boxed{\theta = 75^\circ}$

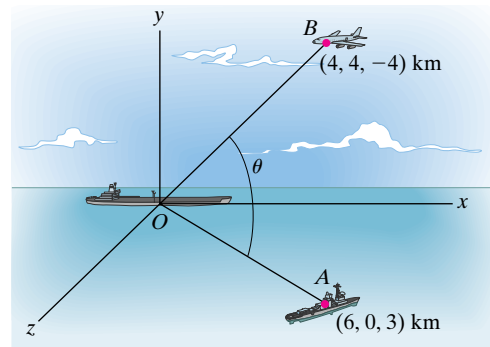

**Problem 2.110** Astronauts on the space shuttle use radar to determine the magnitudes and direction cosines of the position vectors of two satellites  $A$  and  $B$ . The vector  $\mathbf{r}_A$  from the shuttle to satellite  $A$  has magnitude 2 km and direction cosines  $\cos \theta_x = 0.768$ ,  $\cos \theta_y = 0.384$ ,  $\cos \theta_z = 0.512$ . The vector  $\mathbf{r}_B$  from the shuttle to satellite  $B$  has magnitude 4 km and direction cosines  $\cos \theta_x = 0.743$ ,  $\cos \theta_y = 0.557$ ,  $\cos \theta_z = -0.371$ . What is the angle  $\theta$  between the vectors  $\mathbf{r}_A$  and  $\mathbf{r}_B$ ?

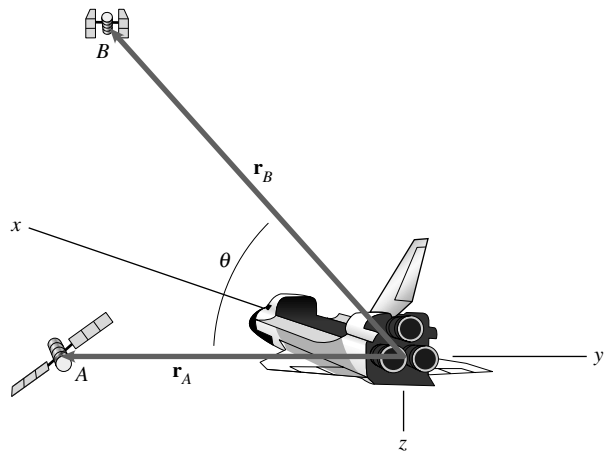

**Solution:** The direction cosines of the vectors along  $\mathbf{r}_A$  and  $\mathbf{r}_B$  are the components of the unit vectors in these directions (i.e.,  $\mathbf{u}_A = \cos \theta_x \mathbf{i} + \cos \theta_y \mathbf{j} + \cos \theta_z \mathbf{k}$ , where the direction cosines are those for  $\mathbf{r}_A$ ). Thus, through the definition of the dot product, we can find an expression for the cosine of the angle between  $\mathbf{r}_A$  and  $\mathbf{r}_B$ .

$$\cos \theta = \cos \theta_{x_A} \cos \theta_{x_B} + \cos \theta_{y_A} \cos \theta_{y_B} + \cos \theta_{z_A} \cos \theta_{z_B}.$$

Evaluation of the relation yields

$$\boxed{\cos \theta = 0.594 \Rightarrow \theta = 53.5^\circ}$$

**Problem 2.111** In Example 2.13, if you shift your position and the coordinates of point  $A$  where you apply the 50-N force become  $(8, 3, -3)$  m, what is the vector component of  $\mathbf{F}$  parallel to the cable  $OB$ ?

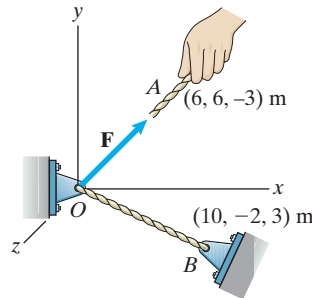

**Solution:** We use the following vectors to define the force  $\mathbf{F}$ .

$$\mathbf{r}_{OA} = (8\mathbf{i} + 3\mathbf{j} - 3\mathbf{k}) \text{ m}$$

$$\mathbf{e}_{OA} = \frac{\mathbf{r}_{OA}}{|\mathbf{r}_{OA}|} = (0.833\mathbf{i} + 0.331\mathbf{j} - 0.331\mathbf{k})$$

$$\mathbf{F} = (50 \text{ N})\mathbf{e}_{OA} = (44.2\mathbf{i} + 16.6\mathbf{j} - 16.6\mathbf{k}) \text{ N}$$

Now we need the unit vector  $\mathbf{e}_{OB}$ .

$$\mathbf{r}_{OB} = (10\mathbf{i} - 2\mathbf{j} + 3\mathbf{k}) \text{ m}$$

$$\mathbf{e}_{OB} = \frac{\mathbf{r}_{OB}}{|\mathbf{r}_{OB}|} = (0.941\mathbf{i} - 0.188\mathbf{j} + 0.282\mathbf{k})$$

To find the vector component parallel to  $OB$  we use the dot product in the following manner

$$\mathbf{F} \cdot \mathbf{e}_{OB} = (44.2 \text{ N})(0.941) + (16.6 \text{ N})(-0.188) + (-16.6 \text{ N})(0.282) = 33.8 \text{ N}$$

$$\mathbf{F}_p = (\mathbf{F} \cdot \mathbf{e}_{OB})\mathbf{e}_{OB} = (33.8 \text{ N})(0.941\mathbf{i} - 0.188\mathbf{j} + 0.282\mathbf{k})$$

$$\boxed{\mathbf{F}_p = (31.8\mathbf{i} - 6.35\mathbf{j} + 9.53\mathbf{k}) \text{ N}}$$

**Problem 2.112** The person exerts a force  $\mathbf{F} = 60\mathbf{i} - 40\mathbf{j}$  (N) on the handle of the exercise machine. Use Eq. (2.26) to determine the vector component of  $\mathbf{F}$  that is parallel to the line from the origin  $O$  to where the person grips the handle.

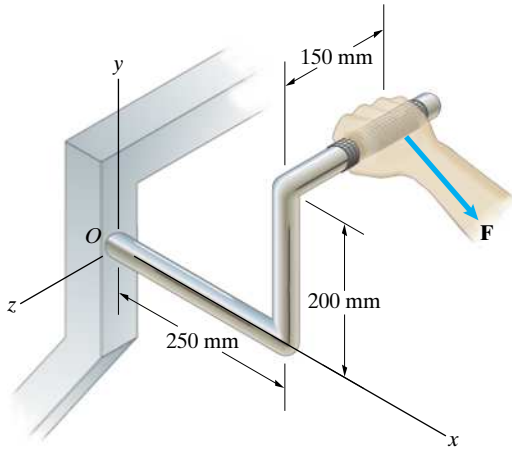

**Solution:** The vector  $\mathbf{r}$  from the  $O$  to where the person grips the handle is

$$\mathbf{r} = (250\mathbf{i} + 200\mathbf{j} - 150\mathbf{k}) \text{ mm},$$

$$|\mathbf{r}| = 354 \text{ mm}$$

To produce the unit vector that is parallel to this line we divide by the magnitude

$$\mathbf{e} = \frac{\mathbf{r}}{|\mathbf{r}|} = \frac{(250\mathbf{i} + 200\mathbf{j} - 150\mathbf{k}) \text{ mm}}{354 \text{ mm}} = (0.707\mathbf{i} + 0.566\mathbf{j} - 0.424\mathbf{k})$$

Using Eq. (2.26), we find that the vector component parallel to the line is

$$\begin{aligned} \mathbf{F}_p &= (\mathbf{e} \cdot \mathbf{F})\mathbf{e} = [(0.707)(60 \text{ N}) + (0.566)(-40 \text{ N})](0.707\mathbf{i} \\ &\quad + 0.566\mathbf{j} - 0.424\mathbf{k}) \end{aligned}$$

$$\boxed{\mathbf{F}_p = (14.0\mathbf{i} + 11.2\mathbf{j} + 8.4\mathbf{k}) \text{ N}}$$

**Problem 2.113** At the instant shown, the Harrier's thrust vector is  $\mathbf{T} = 17,000\mathbf{i} + 68,000\mathbf{j} - 8,000\mathbf{k}$  (N) and its velocity vector is  $\mathbf{v} = 7.3\mathbf{i} + 1.8\mathbf{j} - 0.6\mathbf{k}$  (m/s). The quantity  $P = |\mathbf{T}_p||\mathbf{v}|$ , where  $\mathbf{T}_p$  is the vector component of  $\mathbf{T}$  parallel to  $\mathbf{v}$ , is the power currently being transferred to the airplane by its engine. Determine the value of  $P$ .

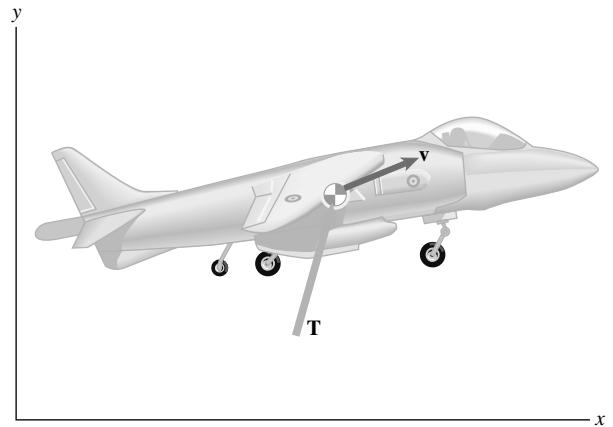

**Solution:**

$$\mathbf{T} = (17,000\mathbf{i} + 68,000\mathbf{j} - 8,000\mathbf{k}) \text{ N}$$

$$\mathbf{v} = (7.3\mathbf{i} + 1.8\mathbf{j} - 0.6\mathbf{k}) \text{ m/s}$$

$$\begin{aligned} \text{Power} &= \mathbf{T} \cdot \mathbf{v} = (17,000 \text{ N})(7.3 \text{ m/s}) + (68,000 \text{ N})(1.8 \text{ m/s}) \\ &\quad + (-8,000 \text{ N})(-0.6 \text{ m/s}) \end{aligned}$$

$$\boxed{\text{Power} = 251,000 \text{ Nm/s} = 251 \text{ kW}}$$

**Problem 2.114** Cables extend from  $A$  to  $B$  and from  $A$  to  $C$ . The cable  $AC$  exerts a 1000-lb force  $\mathbf{F}$  at  $A$ .

- (a) What is the angle between the cables  $AB$  and  $AC$ ?  
 (b) Determine the vector component of  $\mathbf{F}$  parallel to the cable  $AB$ .

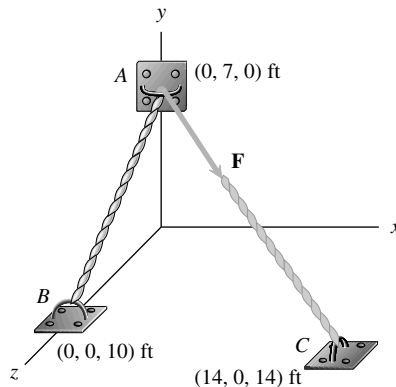

**Solution:** Use Eq. (2.24) to solve.

- (a) From the coordinates of the points, the position vectors are:

$$\mathbf{r}_{AB} = (0 - 0)\mathbf{i} + (0 - 7)\mathbf{j} + (10 - 0)\mathbf{k}$$

$$\mathbf{r}_{AB} = 0\mathbf{i} - 7\mathbf{j} + 10\mathbf{k}$$

$$\mathbf{r}_{AC} = (14 - 0)\mathbf{i} + (0 - 7)\mathbf{j} + (14 - 0)\mathbf{k}$$

$$\mathbf{r}_{AC} = 14\mathbf{i} - 7\mathbf{j} + 14\mathbf{k}$$

The magnitudes are:

$$|\mathbf{r}_{AB}| = \sqrt{7^2 + 10^2} = 12.2 \text{ (ft) and}$$

$$|\mathbf{r}_{AC}| = \sqrt{14^2 + 7^2 + 14^2} = 21.$$

The dot product is given by

$$\mathbf{r}_{AB} \cdot \mathbf{r}_{AC} = (14)(0) + (-7)(-7) + (10)(14) = 189.$$

The angle is given by

$$\cos \theta = \frac{189}{(12.2)(21)} = 0.7377,$$

from which  $\theta = \pm 42.5^\circ$ . From the construction:  $\theta = +42.5^\circ$

- (b) The unit vector associated with  $AB$  is

$$\mathbf{e}_{AB} = \frac{\mathbf{r}_{AB}}{|\mathbf{r}_{AB}|} = 0\mathbf{i} - 0.5738\mathbf{j} + 0.8197\mathbf{k}.$$

The unit vector associated with  $AC$  is

$$\mathbf{e}_{AC} = \frac{\mathbf{r}_{AC}}{|\mathbf{r}_{AC}|} = 0.6667\mathbf{i} - 0.3333\mathbf{j} + 0.6667\mathbf{k}.$$

Thus the force vector along  $AC$  is

$$\mathbf{F}_{AC} = |\mathbf{F}|\mathbf{e}_{AC} = 666.7\mathbf{i} - 333.3\mathbf{j} + 666.7\mathbf{k}.$$

The component of this force parallel to  $AB$  is

$$(\mathbf{F}_{AC} \cdot \mathbf{e}_{AB})\mathbf{e}_{AB} = (737.5)\mathbf{e}_{AB} = 0\mathbf{i} - 422.8\mathbf{j} + 604.5\mathbf{k} \text{ (lb)}$$

**Problem 2.115** Consider the cables  $AB$  and  $AC$  shown in Problem 2.114. Let  $\mathbf{r}_{AB}$  be the position vector from point  $A$  to point  $B$ . Determine the vector component of  $\mathbf{r}_{AB}$  parallel to the cable  $AC$ .

**Solution:** From Problem 2.114,  $\mathbf{r}_{AB} = 0\mathbf{i} - 7\mathbf{j} + 10\mathbf{k}$ , and  $\mathbf{e}_{AC} = 0.6667\mathbf{i} - 0.3333\mathbf{j} + 0.6667\mathbf{k}$ . Thus  $\mathbf{r}_{AB} \cdot \mathbf{e}_{AC} = 9$ , and  $(\mathbf{r}_{AB} \cdot \mathbf{e}_{AC})\mathbf{e}_{AC} = (6\mathbf{i} - 3\mathbf{j} + 6\mathbf{k})$  ft.

**Problem 2.116** The force  $\mathbf{F} = 10\mathbf{i} + 12\mathbf{j} - 6\mathbf{k}$  (N). Determine the vector components of  $\mathbf{F}$  parallel and normal to line  $OA$ .

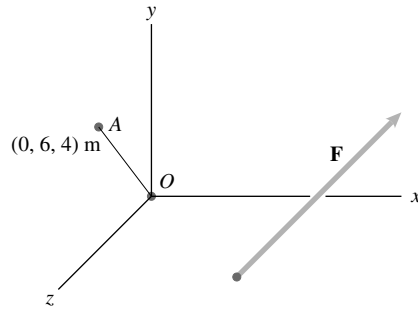

**Solution:** Find  $\mathbf{e}_{OA} = \frac{\mathbf{r}_{OA}}{|\mathbf{r}_{OA}|}$

Then

$$\mathbf{F}_P = (\mathbf{F} \cdot \mathbf{e}_{OA})\mathbf{e}_{OA}$$

and  $\mathbf{F}_N = \mathbf{F} - \mathbf{F}_P$

$$\mathbf{e}_{OA} = \frac{0\mathbf{i} + 6\mathbf{j} + 4\mathbf{k}}{\sqrt{6^2 + 4^2}} = \frac{6\mathbf{j} + 4\mathbf{k}}{\sqrt{52}}$$

$$\mathbf{e}_{OA} = \frac{6}{7.21}\mathbf{j} + \frac{4}{7.21}\mathbf{k} = 0.832\mathbf{j} + 0.555\mathbf{k}$$

$$\mathbf{F}_P = [(10\mathbf{i} + 12\mathbf{j} - 6\mathbf{k}) \cdot (0.832\mathbf{j} + 0.555\mathbf{k})]\mathbf{e}_{OA}$$

$$\mathbf{F}_P = [6.656]\mathbf{e}_{OA} = 0\mathbf{i} + 5.54\mathbf{j} + 3.69\mathbf{k} \text{ (N)}$$

$$\mathbf{F}_N = \mathbf{F} - \mathbf{F}_P$$

$$\mathbf{F}_N = 10\mathbf{i} + (12 - 5.54)\mathbf{j} + (-6 - 3.69)\mathbf{k}$$

$$\mathbf{F}_N = 10\mathbf{i} + 6.46\mathbf{j} - 9.69\mathbf{k} \text{ N}$$

**Problem 2.117** The rope  $AB$  exerts a 50-N force  $\mathbf{T}$  on collar  $A$ . Determine the vector component of  $\mathbf{T}$  parallel to the bar  $CD$ .

**Solution:** We have the following vectors

$$\mathbf{r}_{CD} = (-0.2\mathbf{i} - 0.3\mathbf{j} + 0.25\mathbf{k}) \text{ m}$$

$$\mathbf{e}_{CD} = \frac{\mathbf{r}_{CD}}{|\mathbf{r}_{CD}|} = (-0.456\mathbf{i} - 0.684\mathbf{j} + 0.570\mathbf{k})$$

$$\mathbf{r}_{OB} = (0.5\mathbf{j} + 0.15\mathbf{k}) \text{ m}$$

$$\mathbf{r}_{OC} = (0.4\mathbf{i} + 0.3\mathbf{j}) \text{ m}$$

$$\mathbf{r}_{OA} = \mathbf{r}_{OC} + (0.2 \text{ m})\mathbf{e}_{CD} = (0.309\mathbf{i} + 0.163\mathbf{j} + 0.114\mathbf{k}) \text{ m}$$

$$\mathbf{r}_{AB} = \mathbf{r}_{OB} - \mathbf{r}_{OA} = (-0.309\mathbf{i} + 0.337\mathbf{j} + 0.036\mathbf{k}) \text{ m}$$

$$\mathbf{e}_{AB} = \frac{\mathbf{r}_{AB}}{|\mathbf{r}_{AB}|} = (0.674\mathbf{i} + 0.735\mathbf{j} + 0.079\mathbf{k})$$

We can now write the force  $\mathbf{T}$  and determine the vector component parallel to  $CD$ .

$$\mathbf{T} = (50 \text{ N})\mathbf{e}_{AB} = (-33.7\mathbf{i} + 36.7\mathbf{j} + 3.93\mathbf{k}) \text{ N}$$

$$\mathbf{T}_p = (\mathbf{e}_{CD} \cdot \mathbf{T})\mathbf{e}_{CD} = (3.43\mathbf{i} + 5.14\mathbf{j} - 4.29\mathbf{k}) \text{ N}$$

$$\boxed{\mathbf{T}_p = (3.43\mathbf{i} + 5.14\mathbf{j} - 4.29\mathbf{k}) \text{ N}}$$

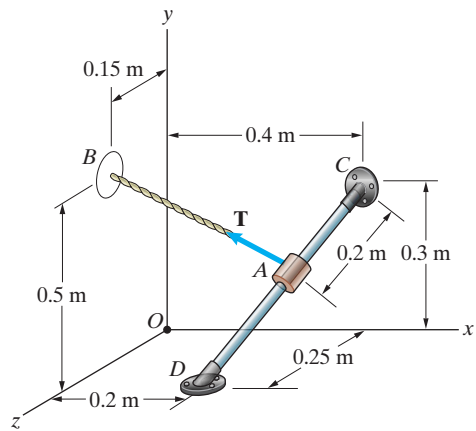

**Problem 2.118** In Problem 2.117, determine the vector component of  $\mathbf{T}$  normal to the bar  $CD$ .

**Solution:** From Problem 2.117 we have

$$\mathbf{T} = (-33.7\mathbf{i} + 36.7\mathbf{j} + 3.93\mathbf{k}) \text{ N}$$

$$\mathbf{T}_p = (3.43\mathbf{i} + 5.14\mathbf{j} - 4.29\mathbf{k}) \text{ N}$$

The normal component is then

$$\mathbf{T}_n = \mathbf{T} - \mathbf{T}_p$$

$$\boxed{\mathbf{T}_n = (-37.1\mathbf{i} + 31.6\mathbf{j} + 8.22\mathbf{k}) \text{ N}}$$

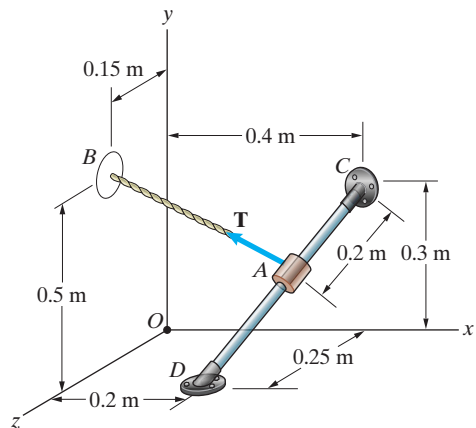



**Problem 2.119** The disk  $A$  is at the midpoint of the sloped surface. The string from  $A$  to  $B$  exerts a 0.2-lb force  $\mathbf{F}$  on the disk. If you express  $\mathbf{F}$  in terms of vector components parallel and normal to the sloped surface, what is the component normal to the surface?

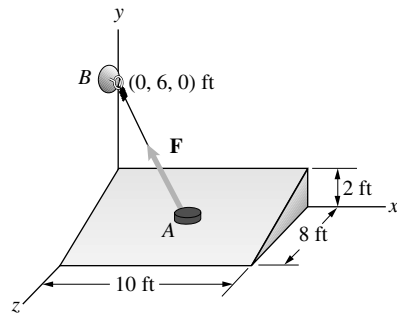

**Solution:** Consider a line on the sloped surface from  $A$  perpendicular to the surface. (see the diagram above) By SIMILAR triangles we see that one such vector is  $\mathbf{r}_N = 8\mathbf{j} + 2\mathbf{k}$ . Let us find the component of  $\mathbf{F}$  parallel to this line.

The unit vector in the direction normal to the surface is

$$\mathbf{e}_N = \frac{\mathbf{r}_N}{|\mathbf{r}_N|} = \frac{8\mathbf{j} + 2\mathbf{k}}{\sqrt{8^2 + 2^2}} = 0.970\mathbf{j} + 0.243\mathbf{k}$$

The unit vector  $\mathbf{e}_{AB}$  can be found by

$$\mathbf{e}_{AB} = \frac{(x_B - x_A)\mathbf{i} + (y_B - y_A)\mathbf{j} + (z_B - z_A)\mathbf{h}}{\sqrt{(x_B - x_A)^2 + (y_B - y_A)^2 + (z_B - z_A)^2}}$$

Point  $B$  is at  $(0, 6, 0)$  (ft) and  $A$  is at  $(5, 1, 4)$  (ft).

Substituting, we get

$$\mathbf{e}_{AB} = -0.615\mathbf{i} + 0.615\mathbf{j} - 0.492\mathbf{k}$$

Now  $\mathbf{F} = |\mathbf{F}|\mathbf{e}_{AB} = (0.2)\mathbf{e}_{AB}$

$$\mathbf{F} = -0.123\mathbf{i} + 0.123\mathbf{j} - 0.0984\mathbf{k} \text{ (lb)}$$

The component of  $\mathbf{F}$  normal to the surface is the component parallel to the unit vector  $\mathbf{e}_N$ .

$$\mathbf{F}_{\text{NORMAL}} = (\mathbf{F} \cdot \mathbf{e}_N)\mathbf{e}_N = (0.955)\mathbf{e}_N$$

$$\mathbf{F}_{\text{NORMAL}} = 0\mathbf{i} + 0.0927\mathbf{j} + 0.0232\mathbf{k} \text{ lb}$$

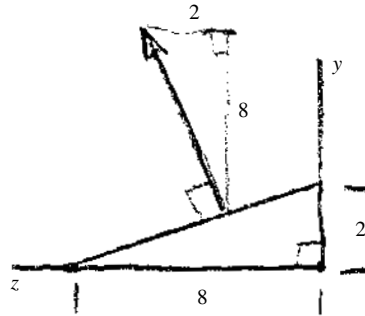

**Problem 2.120** In Problem 2.119, what is the vector component of  $\mathbf{F}$  parallel to the surface?

**Solution:** From the solution to Problem 2.119,

$$\mathbf{F} = -0.123\mathbf{i} + 0.123\mathbf{j} - 0.0984\mathbf{k} \text{ (lb) and}$$

$$\mathbf{F}_{\text{NORMAL}} = 0\mathbf{i} + 0.0927\mathbf{j} + 0.0232\mathbf{k} \text{ (lb)}$$

The component parallel to the surface and the component normal to the surface add to give  $\mathbf{F}(\mathbf{F} = \mathbf{F}_{\text{NORMAL}} + \mathbf{F}_{\text{parallel}})$ .

Thus

$$\mathbf{F}_{\text{parallel}} = \mathbf{F} - \mathbf{F}_{\text{NORMAL}}$$

Substituting, we get

$$\mathbf{F}_{\text{parallel}} = -0.1231\mathbf{i} + 0.0304\mathbf{j} - 0.1216\mathbf{k} \text{ lb}$$

**Problem 2.121** An astronaut in a maneuvering unit approaches a space station. At the present instant, the station informs him that his position relative to the origin of the station's coordinate system is  $\mathbf{r}_G = 50\mathbf{i} + 80\mathbf{j} + 180\mathbf{k}$  (m) and his velocity is  $\mathbf{v} = -2.2\mathbf{j} - 3.6\mathbf{k}$  (m/s). The position of the airlock is  $\mathbf{r}_A = -12\mathbf{i} + 20\mathbf{k}$  (m). Determine the angle between his velocity vector and the line from his position to the airlock's position.

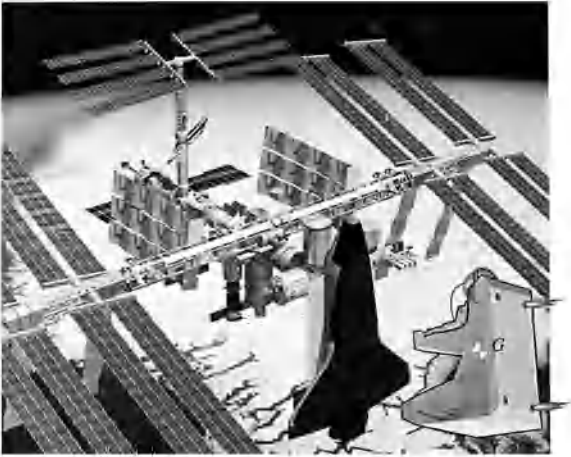

**Solution:** Points  $G$  and  $A$  are located at  $G: (50, 80, 180)$  m and  $A: (-12, 0, 20)$  m. The vector  $\mathbf{r}_{GA}$  is  $\mathbf{r}_{GA} = (x_A - x_G)\mathbf{i} + (y_A - y_G)\mathbf{j} + (z_A - z_G)\mathbf{k} = (-12 - 50)\mathbf{i} + (0 - 80)\mathbf{j} + (20 - 180)\mathbf{k}$  m. The dot product between  $\mathbf{v}$  and  $\mathbf{r}_{GA}$  is  $\mathbf{v} \cdot \mathbf{r}_{GA} = |\mathbf{v}||\mathbf{r}_{GA}|\cos\theta = v_x x_{GA} + v_y y_{GA} + v_z z_{GA}$ , where  $\theta$  is the angle between  $\mathbf{v}$  and  $\mathbf{r}_{GA}$ . Substituting in the numerical values, we get  $\theta = 19.7^\circ$ .

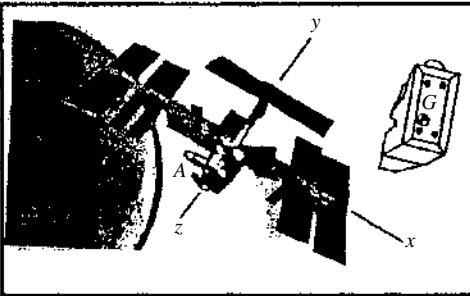

**Problem 2.122** In Problem 2.121, determine the vector component of the astronaut's velocity parallel to the line from his position to the airlock's position.

**Solution:** The coordinates are  $A(-12, 0, 20)$  m,  $G(50, 80, 180)$  m. Therefore

$$\mathbf{r}_{GA} = (-62\mathbf{i} - 80\mathbf{j} - 160\mathbf{k}) \text{ m}$$

$$\mathbf{e}_{GA} = \frac{\mathbf{r}_{GA}}{|\mathbf{r}_{GA}|} = (-0.327\mathbf{i} - 0.423\mathbf{j} - 0.845\mathbf{k})$$

The velocity is given as

$$\mathbf{v} = (-2.2\mathbf{j} - 3.6\mathbf{k}) \text{ m/s}$$

The vector component parallel to the line is now

$$\mathbf{v}_p = (\mathbf{e}_{GA} \cdot \mathbf{v})\mathbf{e}_{GA} = [(-0.423)(-2.2) + (-0.845)(-3.6)]\mathbf{e}_{GA}$$

$$\mathbf{v}_p = (-1.30\mathbf{i} - 1.68\mathbf{j} - 3.36\mathbf{k}) \text{ m/s}$$

**Problem 2.123** Point  $P$  is at longitude  $30^\circ\text{W}$  and latitude  $45^\circ\text{N}$  on the Atlantic Ocean between Nova Scotia and France. Point  $Q$  is at longitude  $60^\circ\text{E}$  and latitude  $20^\circ\text{N}$  in the Arabian Sea. Use the dot product to determine the shortest distance along the surface of the earth from  $P$  to  $Q$  in terms of the radius of the earth  $R_E$ .

**Strategy:** Use the dot product to determine the angle between the lines  $OP$  and  $OQ$ ; then use the definition of an angle in radians to determine the distance along the surface of the earth from  $P$  to  $Q$ .

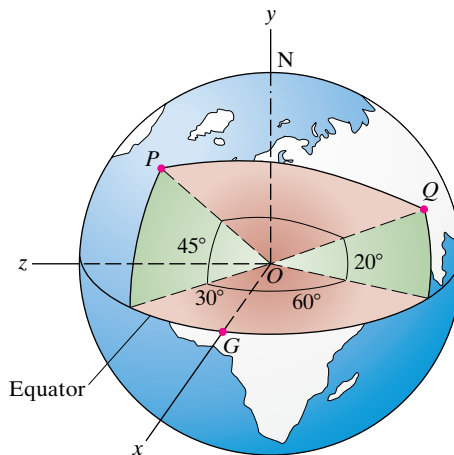

**Solution:** The distance is the product of the angle and the radius of the sphere,  $d = R_E\theta$ , where  $\theta$  is in radian measure. From Eqs. (2.18) and (2.24), the angular separation of  $P$  and  $Q$  is given by

$$\cos \theta = \frac{\mathbf{P} \cdot \mathbf{Q}}{|\mathbf{P}||\mathbf{Q}|}.$$

The strategy is to determine the angle  $\theta$  in terms of the latitude and longitude of the two points. Drop a vertical line from each point  $P$  and  $Q$  to  $b$  and  $c$  on the equatorial plane. The vector position of  $P$  is the sum of the two vectors:  $\mathbf{P} = \mathbf{r}_{OB} + \mathbf{r}_{BP}$ . The vector  $\mathbf{r}_{OB} = |\mathbf{r}_{OB}|(\mathbf{i} \cos \lambda_P + \mathbf{j} \sin \lambda_P)$ . From geometry, the magnitude is  $|\mathbf{r}_{OB}| = R_E \cos \theta_P$ . The vector  $\mathbf{r}_{BP} = |\mathbf{r}_{BP}|(\mathbf{0i} + \mathbf{1j} + \mathbf{0k})$ . From geometry, the magnitude is  $|\mathbf{r}_{BP}| = R_E \sin \theta_P$ . Substitute and reduce to obtain:

$$\mathbf{P} = \mathbf{r}_{OB} + \mathbf{r}_{BP} = R_E(\mathbf{i} \cos \lambda_P \cos \theta_P + \mathbf{j} \sin \theta_P + \mathbf{k} \sin \lambda_P \cos \theta_P).$$

A similar argument for the point  $Q$  yields

$$\mathbf{Q} = \mathbf{r}_{OC} + \mathbf{r}_{CQ} = R_E(\mathbf{i} \cos \lambda_Q \cos \theta_Q + \mathbf{j} \sin \theta_Q + \mathbf{k} \sin \lambda_Q \cos \theta_Q)$$

Using the identity  $\cos^2 \beta + \sin^2 \beta = 1$ , the magnitudes are

$$|\mathbf{P}| = |\mathbf{Q}| = R_E$$

The dot product is

$$\mathbf{P} \cdot \mathbf{Q} = R_E^2(\cos(\lambda_P - \lambda_Q) \cos \theta_P \cos \theta_Q + \sin \theta_P \sin \theta_Q)$$

Substitute:

$$\cos \theta = \frac{\mathbf{P} \cdot \mathbf{Q}}{|\mathbf{P}||\mathbf{Q}|} = \cos(\lambda_P - \lambda_Q) \cos \theta_P \cos \theta_Q + \sin \theta_P \sin \theta_Q$$

Substitute  $\lambda_P = +30^\circ$ ,  $\lambda_Q = -60^\circ$ ,  $\theta_P = +45^\circ$ ,  $\theta_Q = +20^\circ$ , to obtain  $\cos \theta = 0.2418$ , or  $\theta = 1.326$  radians. Thus the distance is  $d = 1.326R_E$

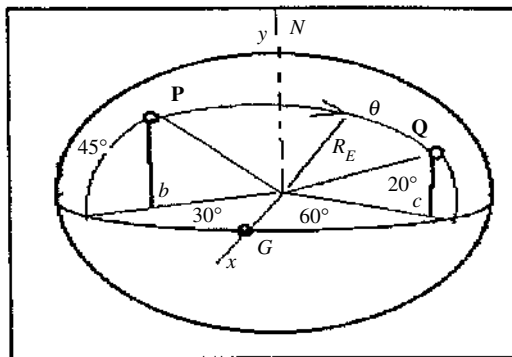

**Problem 2.124** In Active Example 2.14, suppose that the vector  $\mathbf{V}$  is changed to  $\mathbf{V} = 4\mathbf{i} - 6\mathbf{j} - 10\mathbf{k}$ . (a) Determine the cross product  $\mathbf{U} \times \mathbf{V}$ . (b) Use the dot product to prove that  $\mathbf{U} \times \mathbf{V}$  is perpendicular to  $\mathbf{V}$ .

**Solution:** We have  $\mathbf{U} = 6\mathbf{i} - 5\mathbf{j} - \mathbf{k}$ ,  $\mathbf{V} = 4\mathbf{k} - 6\mathbf{j} - 10\mathbf{k}$

$$(a) \quad \mathbf{U} \times \mathbf{V} = \begin{vmatrix} \mathbf{i} & \mathbf{j} & \mathbf{k} \\ 6 & -5 & -1 \\ 4 & -6 & -10 \end{vmatrix} = 44\mathbf{i} + 56\mathbf{j} - 16\mathbf{k}$$

$$\mathbf{U} \times \mathbf{V} = 44\mathbf{i} + 56\mathbf{j} - 16\mathbf{k}$$

$$(b) \quad (\mathbf{U} \times \mathbf{V}) \cdot \mathbf{V} = (44)(4) + (56)(-6) + (-16)(-10) = 0 \Rightarrow$$

$$(\mathbf{U} \times \mathbf{V}) \perp \mathbf{V}$$

**Problem 2.125** Two vectors  $\mathbf{U} = 3\mathbf{i} + 2\mathbf{j}$  and  $\mathbf{V} = 2\mathbf{i} + 4\mathbf{j}$ .

- (a) What is the cross product  $\mathbf{U} \times \mathbf{V}$ ?  
 (b) What is the cross product  $\mathbf{V} \times \mathbf{U}$ ?

**Solution:** Use Eq. (2.34) and expand into 2 by 2 determinants.

$$\mathbf{U} \times \mathbf{V} = \begin{vmatrix} \mathbf{i} & \mathbf{j} & \mathbf{k} \\ 3 & 2 & 0 \\ 2 & 4 & 0 \end{vmatrix} = \mathbf{i}((2)(0) - (4)(0)) - \mathbf{j}((3)(0) - (2)(0)) + \mathbf{k}((3)(4) - (2)(2)) = 8\mathbf{k}$$

$$\mathbf{V} \times \mathbf{U} = \begin{vmatrix} \mathbf{i} & \mathbf{j} & \mathbf{k} \\ 2 & 4 & 0 \\ 3 & 2 & 0 \end{vmatrix} = \mathbf{i}((4)(0) - (2)(0)) - \mathbf{j}((2)(0) - (3)(0)) + \mathbf{k}((2)(2) - (3)(4)) = -8\mathbf{k}$$

**Problem 2.126** The two segments of the L-shaped bar are parallel to the  $x$  and  $z$  axes. The rope  $AB$  exerts a force of magnitude  $|\mathbf{F}| = 500$  lb on the bar at  $A$ . Determine the cross product  $\mathbf{r}_{CA} \times \mathbf{F}$ , where  $\mathbf{r}_{CA}$  is the position vector from point  $C$  to point  $A$ .

**Solution:** We need to determine the force  $\mathbf{F}$  in terms of its components. The vector from  $A$  to  $B$  is used to define  $\mathbf{F}$ .

$$\mathbf{r}_{AB} = (2\mathbf{i} - 4\mathbf{j} - \mathbf{k}) \text{ ft}$$

$$\mathbf{F} = (500 \text{ lb}) \frac{\mathbf{r}_{AB}}{|\mathbf{r}_{AB}|} = (500 \text{ lb}) \frac{(2\mathbf{i} - 4\mathbf{j} - \mathbf{k})}{\sqrt{(2)^2 + (-4)^2 + (-1)^2}}$$

$$\mathbf{F} = (218\mathbf{i} - 436\mathbf{j} - 109\mathbf{k}) \text{ lb}$$

Also we have  $\mathbf{r}_{CA} = (4\mathbf{i} + 5\mathbf{k})$  ft

Therefore

$$\mathbf{r}_{CA} \times \mathbf{F} = \begin{vmatrix} \mathbf{i} & \mathbf{j} & \mathbf{k} \\ 4 & 0 & 5 \\ 218 & -436 & -109 \end{vmatrix} = (2180\mathbf{i} + 1530\mathbf{j} - 1750\mathbf{k}) \text{ ft-lb}$$

$$\boxed{\mathbf{r}_{CA} \times \mathbf{F} = (2180\mathbf{i} + 1530\mathbf{j} - 1750\mathbf{k}) \text{ ft-lb}}$$

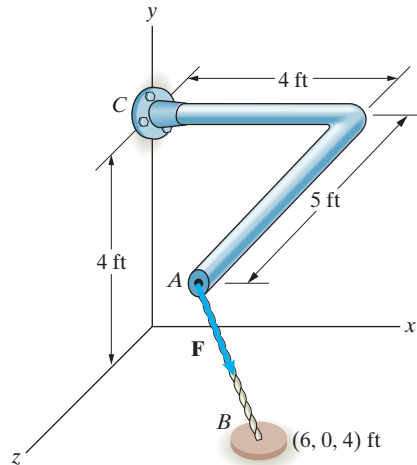

**Problem 2.127** The two segments of the L-shaped bar are parallel to the  $x$  and  $z$  axes. The rope  $AB$  exerts a force of magnitude  $|\mathbf{F}| = 500$  lb on the bar at  $A$ . Determine the cross product  $\mathbf{r}_{CB} \times \mathbf{F}$ , where  $\mathbf{r}_{CB}$  is the position vector from point  $C$  to point  $B$ . Compare your answers to the answer to Problem 2.126.

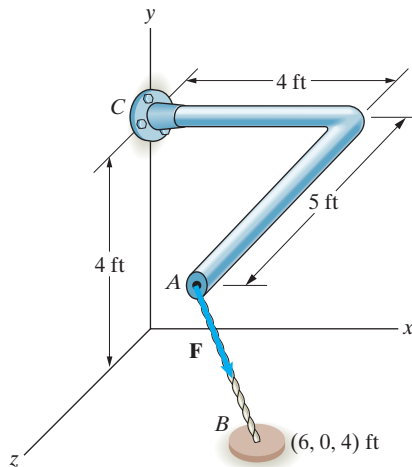

**Solution:** We need to determine the force  $\mathbf{F}$  in terms of its components. The vector from  $A$  to  $B$  is used to define  $\mathbf{F}$ .

$$\mathbf{r}_{AB} = (2\mathbf{i} - 4\mathbf{j} - \mathbf{k}) \text{ ft}$$

$$\mathbf{F} = (500 \text{ lb}) \frac{\mathbf{r}_{AB}}{|\mathbf{r}_{AB}|} = (500 \text{ lb}) \frac{(2\mathbf{i} - 4\mathbf{j} - \mathbf{k})}{\sqrt{(2)^2 + (-4)^2 + (-1)^2}}$$

$$\mathbf{F} = (218\mathbf{i} - 436\mathbf{j} - 109\mathbf{k}) \text{ lb}$$

Also we have  $\mathbf{r}_{CB} = (6\mathbf{i} - 4\mathbf{j} + 4\mathbf{k})$  ft

Therefore

$$\mathbf{r}_{CB} \times \mathbf{F} = \begin{vmatrix} \mathbf{i} & \mathbf{j} & \mathbf{k} \\ 6 & -4 & 4 \\ 218 & -436 & -109 \end{vmatrix} = (2180\mathbf{i} + 1530\mathbf{j} - 1750\mathbf{k}) \text{ ft}\cdot\text{lb}$$

$$\boxed{\mathbf{r}_{CB} \times \mathbf{F} = (2180\mathbf{i} + 1530\mathbf{j} - 1750\mathbf{k}) \text{ ft}\cdot\text{lb}}$$

The answer is the same for 2.126 and 2.127 because the position vectors just point to different points along the line of action of the force.

**Problem 2.128** Suppose that the cross product of two vectors  $\mathbf{U}$  and  $\mathbf{V}$  is  $\mathbf{U} \times \mathbf{V} = \mathbf{0}$ . If  $|\mathbf{U}| \neq 0$ , what do you know about the vector  $\mathbf{V}$ ?

**Solution:**

$$\boxed{\text{Either } \mathbf{V} = \mathbf{0} \text{ or } \mathbf{V} \parallel \mathbf{U}}$$

**Problem 2.129** The cross product of two vectors  $\mathbf{U}$  and  $\mathbf{V}$  is  $\mathbf{U} \times \mathbf{V} = -30\mathbf{i} + 40\mathbf{k}$ . The vector  $\mathbf{V} = 4\mathbf{i} - 2\mathbf{j} + 3\mathbf{k}$ . The vector  $\mathbf{U} = (4\mathbf{i} + U_y\mathbf{j} + U_z\mathbf{k})$ . Determine  $U_y$  and  $U_z$ .

**Solution:** From the given information we have

$$\begin{aligned} \mathbf{U} \times \mathbf{V} &= \begin{vmatrix} \mathbf{i} & \mathbf{j} & \mathbf{k} \\ 4 & U_y & U_z \\ 4 & -2 & 3 \end{vmatrix} \\ &= (3U_y + 2U_z)\mathbf{i} + (4U_z - 12)\mathbf{j} + (-8 - 4U_y)\mathbf{k} \end{aligned}$$

$$\mathbf{U} \times \mathbf{V} = (-30\mathbf{i} + 40\mathbf{k})$$

Equating the components we have

$$3U_y + 2U_z = -30, \quad 4U_z - 12 = 0, \quad -8 - 4U_y = 40.$$

Solving any two of these three redundant equations gives

$$\boxed{U_y = -12, U_z = 3.}$$

**Problem 2.130** The magnitudes  $|\mathbf{U}| = 10$  and  $|\mathbf{V}| = 20$ .

- Use the definition of the cross product to determine  $\mathbf{U} \times \mathbf{V}$ .
- Use the definition of the cross product to determine  $\mathbf{V} \times \mathbf{U}$ .
- Use Eq. (2.34) to determine  $\mathbf{U} \times \mathbf{V}$ .
- Use Eq. (2.34) to determine  $\mathbf{V} \times \mathbf{U}$ .

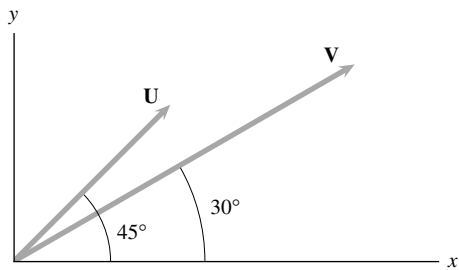

**Solution:** From Eq. (2.28)  $\mathbf{U} \times \mathbf{V} = |\mathbf{U}||\mathbf{V}| \sin \theta \mathbf{e}$ . From the sketch, the positive  $z$ -axis is out of the paper. For  $\mathbf{U} \times \mathbf{V}$ ,  $\mathbf{e} = -1\mathbf{k}$  (points into the paper); for  $\mathbf{V} \times \mathbf{U}$ ,  $\mathbf{e} = +1\mathbf{k}$  (points out of the paper). The angle  $\theta = 15^\circ$ , hence (a)  $\mathbf{U} \times \mathbf{V} = (10)(20)(0.2588)(\mathbf{e}) = 51.8\mathbf{e} = -51.8\mathbf{k}$ . Similarly, (b)  $\mathbf{V} \times \mathbf{U} = 51.8\mathbf{e} = 51.8\mathbf{k}$  (c) The two vectors are:

$$\mathbf{U} = 10(\mathbf{i} \cos 45^\circ + \mathbf{j} \sin 45^\circ) = 7.07\mathbf{i} + 0.707\mathbf{j},$$

$$\mathbf{V} = 20(\mathbf{i} \cos 30^\circ + \mathbf{j} \sin 30^\circ) = 17.32\mathbf{i} + 10\mathbf{j}$$

$$\mathbf{U} \times \mathbf{V} = \begin{vmatrix} \mathbf{i} & \mathbf{j} & \mathbf{k} \\ 7.07 & 7.07 & 0 \\ 17.32 & 10 & 0 \end{vmatrix} = \mathbf{i}(0) - \mathbf{j}(0) + \mathbf{k}(70.7 - 122.45) = -51.8\mathbf{k}$$

$$\mathbf{V} \times \mathbf{U} = \begin{vmatrix} \mathbf{i} & \mathbf{j} & \mathbf{k} \\ 17.32 & 10 & 0 \\ 7.07 & 7.07 & 0 \end{vmatrix} = \mathbf{i}(0) - \mathbf{j}(0) + \mathbf{k}(122.45 - 70.7) = 51.8\mathbf{k}$$

**Problem 2.131** The force  $\mathbf{F} = 10\mathbf{i} - 4\mathbf{j}$  (N). Determine the cross product  $\mathbf{r}_{AB} \times \mathbf{F}$ .

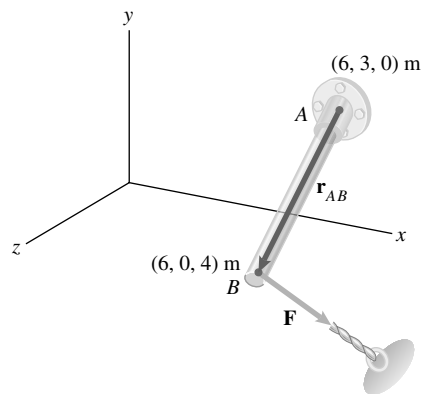

**Solution:** The position vector is

$$\mathbf{r}_{AB} = (6 - 6)\mathbf{i} + (0 - 3)\mathbf{j} + (4 - 0)\mathbf{k} = 0\mathbf{i} - 3\mathbf{j} + 4\mathbf{k}$$

The cross product:

$$\mathbf{r}_{AB} \times \mathbf{F} = \begin{vmatrix} \mathbf{i} & \mathbf{j} & \mathbf{k} \\ 0 & -3 & 4 \\ 10 & -4 & 0 \end{vmatrix} = \mathbf{i}(16) - \mathbf{j}(-40) + \mathbf{k}(30) = 16\mathbf{i} + 40\mathbf{j} + 30\mathbf{k} \text{ (N}\cdot\text{m)}$$

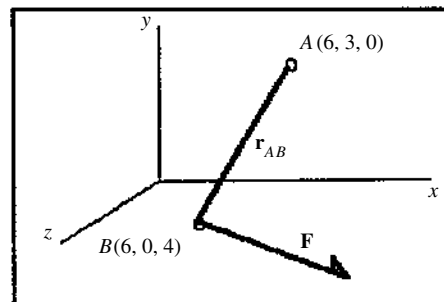

**Problem 2.132** By evaluating the cross product  $\mathbf{U} \times \mathbf{V}$ , prove the identity  $\sin(\theta_1 - \theta_2) = \sin \theta_1 \cos \theta_2 - \cos \theta_1 \sin \theta_2$ .

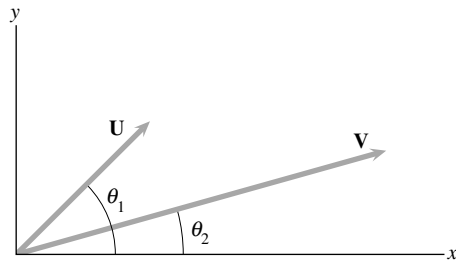

**Solution:** Assume that both  $\mathbf{U}$  and  $\mathbf{V}$  lie in the  $x$ - $y$  plane. The strategy is to use the definition of the cross product (Eq. 2.28) and the Eq. (2.34), and equate the two. From Eq. (2.28)  $\mathbf{U} \times \mathbf{V} = |\mathbf{U}||\mathbf{V}| \sin(\theta_1 - \theta_2)\mathbf{e}$ . Since the positive  $z$ -axis is out of the paper, and  $\mathbf{e}$  points into the paper, then  $\mathbf{e} = -\mathbf{k}$ . Take the dot product of both sides with  $\mathbf{e}$ , and note that  $\mathbf{k} \cdot \mathbf{k} = 1$ . Thus

$$\sin(\theta_1 - \theta_2) = - \left( \frac{(\mathbf{U} \times \mathbf{V}) \cdot \mathbf{k}}{|\mathbf{U}||\mathbf{V}|} \right)$$

The vectors are:

$$\mathbf{U} = |\mathbf{U}|(\mathbf{i} \cos \theta_1 + \mathbf{j} \sin \theta_2), \text{ and } \mathbf{V} = |\mathbf{V}|(\mathbf{i} \cos \theta_2 + \mathbf{j} \sin \theta_2).$$

The cross product is

$$\begin{aligned} \mathbf{U} \times \mathbf{V} &= \begin{vmatrix} \mathbf{i} & \mathbf{j} & \mathbf{k} \\ |\mathbf{U}| \cos \theta_1 & |\mathbf{U}| \sin \theta_1 & 0 \\ |\mathbf{V}| \cos \theta_2 & |\mathbf{V}| \sin \theta_2 & 0 \end{vmatrix} \\ &= \mathbf{i}(0) - \mathbf{j}(0) + \mathbf{k}(|\mathbf{U}||\mathbf{V}|)(\cos \theta_1 \sin \theta_2 - \cos \theta_2 \sin \theta_1) \end{aligned}$$

Substitute into the definition to obtain:  $\sin(\theta_1 - \theta_2) = \sin \theta_1 \cos \theta_2 - \cos \theta_1 \sin \theta_2$ . Q.E.D.

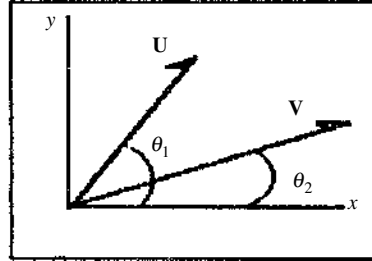

**Problem 2.133** In Example 2.15, what is the minimum distance from point  $B$  to the line  $OA$ ?

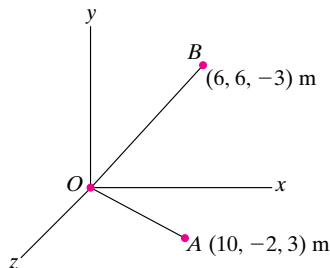

**Solution:** Let  $\theta$  be the angle between  $\mathbf{r}_{OA}$  and  $\mathbf{r}_{OB}$ . Then the minimum distance is

$$d = |\mathbf{r}_{OB}| \sin \theta$$

Using the cross product, we have

$$|\mathbf{r}_{OA} \times \mathbf{r}_{OB}| = |\mathbf{r}_{OA}||\mathbf{r}_{OB}| \sin \theta = |\mathbf{r}_{OA}|d \Rightarrow d = \frac{|\mathbf{r}_{OA} \times \mathbf{r}_{OB}|}{|\mathbf{r}_{OA}|}$$

We have

$$\mathbf{r}_{OA} = (10\mathbf{i} - 2\mathbf{j} + 3\mathbf{k}) \text{ m}$$

$$\mathbf{r}_{OB} = (6\mathbf{i} + 6\mathbf{j} - 3\mathbf{k}) \text{ m}$$

$$\mathbf{r}_{OA} \times \mathbf{r}_{OB} = \begin{vmatrix} \mathbf{i} & \mathbf{j} & \mathbf{k} \\ 10 & -2 & 3 \\ 6 & 6 & -3 \end{vmatrix} = (-12\mathbf{i} + 48\mathbf{j} + 72\mathbf{k}) \text{ m}^2$$

Thus

$$d = \frac{\sqrt{(-12 \text{ m}^2)^2 + (48 \text{ m}^2)^2 + (72 \text{ m}^2)^2}}{\sqrt{(10 \text{ m})^2 + (-2 \text{ m})^2 + (3 \text{ m})^2}} = 8.22 \text{ m}$$

$$d = 8.22 \text{ m}$$

**Problem 2.134** (a) What is the cross product  $\mathbf{r}_{OA} \times \mathbf{r}_{OB}$ ? (b) Determine a unit vector  $\mathbf{e}$  that is perpendicular to  $\mathbf{r}_{OA}$  and  $\mathbf{r}_{OB}$ .

**Solution:** The two radius vectors are

$$\mathbf{r}_{OB} = 4\mathbf{i} + 4\mathbf{j} - 4\mathbf{k}, \quad \mathbf{r}_{OA} = 6\mathbf{i} - 2\mathbf{j} + 3\mathbf{k}$$

(a) The cross product is

$$\begin{aligned} \mathbf{r}_{OA} \times \mathbf{r}_{OB} &= \begin{vmatrix} \mathbf{i} & \mathbf{j} & \mathbf{k} \\ 6 & -2 & 3 \\ 4 & 4 & -4 \end{vmatrix} = \mathbf{i}(8 - 12) - \mathbf{j}(-24 - 12) \\ &\quad + \mathbf{k}(24 + 8) \\ &= -4\mathbf{i} + 36\mathbf{j} + 32\mathbf{k} \text{ (m}^2\text{)} \end{aligned}$$

The magnitude is

$$|\mathbf{r}_{OA} \times \mathbf{r}_{OB}| = \sqrt{4^2 + 36^2 + 32^2} = 48.33 \text{ m}^2$$

(b) The unit vector is

$$\mathbf{e} = \pm \left( \frac{\mathbf{r}_{OA} \times \mathbf{r}_{OB}}{|\mathbf{r}_{OA} \times \mathbf{r}_{OB}|} \right) = \pm(-0.0828\mathbf{i} + 0.7448\mathbf{j} + 0.6621\mathbf{k})$$

(Two vectors.)

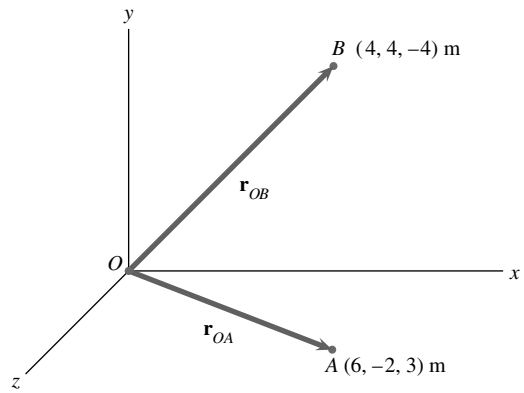

**Problem 2.135** For the points O, A, and B in Problem 2.134, use the cross product to determine the length of the shortest straight line from point B to the straight line that passes through points O and A.

**Solution:**

$$\mathbf{r}_{OA} = 6\mathbf{i} - 2\mathbf{j} + 3\mathbf{k} \text{ (m)}$$

$$\mathbf{r}_{OB} = 4\mathbf{i} + 4\mathbf{j} - 4\mathbf{k} \text{ (m)}$$

$$\mathbf{r}_{OA} \times \mathbf{r}_{OB} = \mathbf{C}$$

(C is  $\perp$  to both  $\mathbf{r}_{OA}$  and  $\mathbf{r}_{OB}$ )

$$\mathbf{C} = \begin{vmatrix} \mathbf{i} & \mathbf{j} & \mathbf{k} \\ 6 & -2 & 3 \\ 4 & 4 & -4 \end{vmatrix} = \begin{matrix} (+8 - 12)\mathbf{i} \\ +(12 + 24)\mathbf{j} \\ +(24 + 8)\mathbf{k} \end{matrix}$$

$$\mathbf{C} = -4\mathbf{i} + 36\mathbf{j} + 32\mathbf{k}$$

C is  $\perp$  to both  $\mathbf{r}_{OA}$  and  $\mathbf{r}_{OB}$ . Any line  $\perp$  to the plane formed by C and  $\mathbf{r}_{OA}$  will be parallel to the line BP on the diagram.  $\mathbf{C} \times \mathbf{r}_{OA}$  is such a line. We then need to find the component of  $\mathbf{r}_{OB}$  in this direction and compute its magnitude.

$$\mathbf{C} \times \mathbf{r}_{OA} = \begin{vmatrix} \mathbf{i} & \mathbf{j} & \mathbf{k} \\ -4 & +36 & 32 \\ 6 & -2 & 3 \end{vmatrix}$$

$$\mathbf{C} \times \mathbf{r}_{OA} = 172\mathbf{i} + 204\mathbf{j} - 208\mathbf{k}$$

The unit vector in the direction of C is

$$\mathbf{e}_C = \frac{\mathbf{C}}{|\mathbf{C}|} = 0.508\mathbf{i} + 0.603\mathbf{j} - 0.614\mathbf{k}$$

(The magnitude of C is 338.3)

We now want to find the length of the projection, P, of line OB in direction  $\mathbf{e}_C$ .

$$\begin{aligned} P &= \mathbf{r}_{OB} \cdot \mathbf{e}_C \\ &= (4\mathbf{i} + 4\mathbf{j} - 4\mathbf{k}) \cdot \mathbf{e}_C \end{aligned}$$

$$P = 6.90 \text{ m}$$

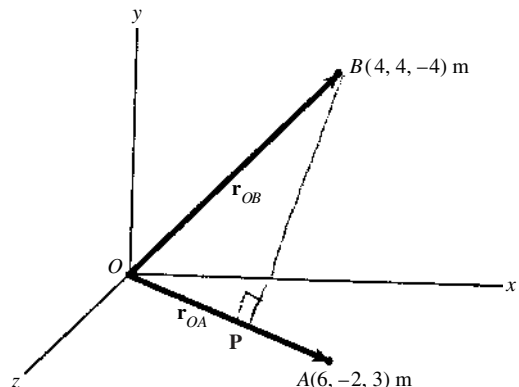



**Problem 2.136** The cable  $BC$  exerts a 1000-lb force  $\mathbf{F}$  on the hook at  $B$ . Determine  $\mathbf{r}_{AB} \times \mathbf{F}$ .

**Solution:** The coordinates of points  $A$ ,  $B$ , and  $C$  are  $A(16, 0, 12)$ ,  $B(4, 6, 0)$ ,  $C(4, 0, 8)$ . The position vectors are

$$\mathbf{r}_{OA} = 16\mathbf{i} + 0\mathbf{j} + 12\mathbf{k}, \mathbf{r}_{OB} = 4\mathbf{i} + 6\mathbf{j} + 0\mathbf{k}, \mathbf{r}_{OC} = 4\mathbf{i} + 0\mathbf{j} + 8\mathbf{k}.$$

The force  $\mathbf{F}$  acts along the unit vector

$$\mathbf{e}_{BC} = \frac{\mathbf{r}_{BC}}{|\mathbf{r}_{BC}|} = \frac{\mathbf{r}_{OC} - \mathbf{r}_{OB}}{|\mathbf{r}_{OC} - \mathbf{r}_{OB}|} = \frac{\mathbf{r}_{AB}}{|\mathbf{r}_{AB}|}$$

$$\text{Noting } \mathbf{r}_{OC} - \mathbf{r}_{OB} = (4 - 4)\mathbf{i} + (0 - 6)\mathbf{j} + (8 - 0)\mathbf{k} = 0\mathbf{i} - 6\mathbf{j} + 8\mathbf{k}$$

$$|\mathbf{r}_{OC} - \mathbf{r}_{OB}| = \sqrt{6^2 + 8^2} = 10. \text{ Thus}$$

$$\mathbf{e}_{BC} = 0\mathbf{i} - 0.6\mathbf{j} + 0.8\mathbf{k}, \text{ and } \mathbf{F} = |\mathbf{F}|\mathbf{e}_{BC} = 0\mathbf{i} - 600\mathbf{j} + 800\mathbf{k} \text{ (lb).}$$

The vector

$$\mathbf{r}_{AB} = (4 - 16)\mathbf{i} + (6 - 0)\mathbf{j} + (0 - 12)\mathbf{k} = -12\mathbf{i} + 6\mathbf{j} - 12\mathbf{k}$$

Thus the cross product is

$$\mathbf{r}_{AB} \times \mathbf{F} = \begin{vmatrix} \mathbf{i} & \mathbf{j} & \mathbf{k} \\ -12 & 6 & -12 \\ 0 & -600 & 800 \end{vmatrix} = -2400\mathbf{i} + 9600\mathbf{j} + 7200\mathbf{k} \text{ (ft-lb)}$$

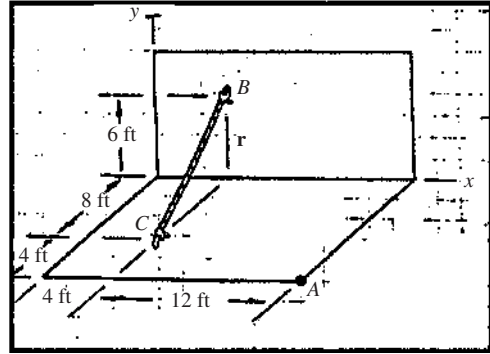
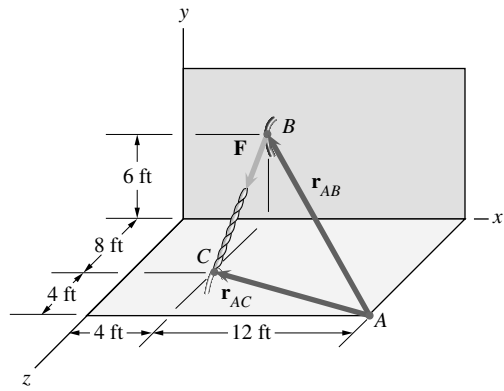

**Problem 2.137** The force vector  $\mathbf{F}$  points along the straight line from point  $A$  to point  $B$ . Its magnitude is  $|\mathbf{F}| = 20$  N. The coordinates of points  $A$  and  $B$  are  $x_A = 6$  m,  $y_A = 8$  m,  $z_A = 4$  m and  $x_B = 8$  m,  $y_B = 1$  m,  $z_B = -2$  m.

- Express the vector  $\mathbf{F}$  in terms of its components.
- Use Eq. (2.34) to determine the cross products  $\mathbf{r}_A \times \mathbf{F}$  and  $\mathbf{r}_B \times \mathbf{F}$ .

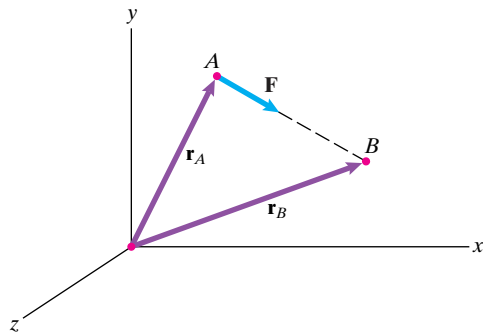

**Solution:** We have  $\mathbf{r}_A = (6\mathbf{i} + 8\mathbf{j} + 4\mathbf{k})$  m,  $\mathbf{r}_B = (8\mathbf{i} + \mathbf{j} - 2\mathbf{k})$  m,

$$\begin{aligned} \mathbf{F} &= (20 \text{ N}) \frac{(8 - 6)\mathbf{i} + (1 - 8)\mathbf{j} + (-2 - 4)\mathbf{k}}{\sqrt{(2 \text{ m})^2 + (-7 \text{ m})^2 + (-6 \text{ m})^2}} \\ \text{(a)} \quad &= \frac{20 \text{ N}}{\sqrt{89}} (2\mathbf{i} - 7\mathbf{j} - 6\mathbf{k}) \end{aligned}$$

$$\begin{aligned} \mathbf{r}_A \times \mathbf{F} &= \frac{20 \text{ N}}{\sqrt{89}} \begin{vmatrix} \mathbf{i} & \mathbf{j} & \mathbf{k} \\ 6 \text{ m} & 8 \text{ m} & 4 \text{ m} \\ 2 & -7 & -6 \end{vmatrix} \\ &= (-42.4\mathbf{i} + 93.3\mathbf{j} - 123.0\mathbf{k}) \text{ Nm} \\ \text{(b)} \quad \mathbf{r}_B \times \mathbf{F} &= \frac{20 \text{ N}}{\sqrt{89}} \begin{vmatrix} \mathbf{i} & \mathbf{j} & \mathbf{k} \\ 8 \text{ m} & 1 \text{ m} & -2 \text{ m} \\ 2 & -7 & -6 \end{vmatrix} \\ &= (-42.4\mathbf{i} + 93.3\mathbf{j} - 123.0\mathbf{k}) \text{ Nm} \end{aligned}$$

Note that both cross products give the same result (as they must).

**Problem 2.138** The rope  $AB$  exerts a 50-N force  $\mathbf{T}$  on the collar at  $A$ . Let  $\mathbf{r}_{CA}$  be the position vector from point  $C$  to point  $A$ . Determine the cross product  $\mathbf{r}_{CA} \times \mathbf{T}$ .

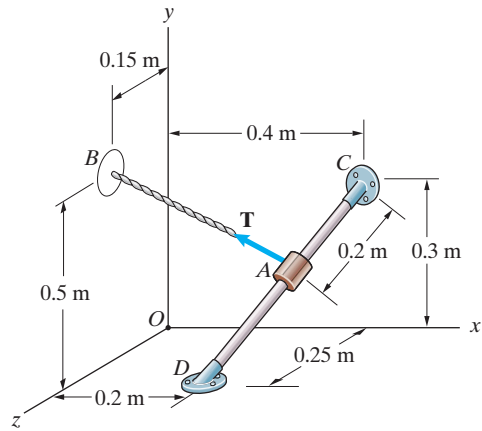

**Solution:** We define the appropriate vectors.

$$\mathbf{r}_{CD} = (-0.2\mathbf{i} - 0.3\mathbf{j} + 0.25\mathbf{k}) \text{ m}$$

$$\mathbf{r}_{CA} = (0.2 \text{ m}) \frac{\mathbf{r}_{CD}}{|\mathbf{r}_{CD}|} = (-0.091\mathbf{i} - 0.137\mathbf{j} + 0.114\mathbf{k}) \text{ m}$$

$$\mathbf{r}_{OB} = (0.5\mathbf{j} + 0.15\mathbf{k}) \text{ m}$$

$$\mathbf{r}_{OC} = (0.4\mathbf{i} + 0.3\mathbf{j}) \text{ m}$$

$$\mathbf{r}_{AB} = \mathbf{r}_{OB} - (\mathbf{r}_{OC} + \mathbf{r}_{CA}) = (0.61\mathbf{i} - 1.22\mathbf{j} - 0.305\mathbf{k}) \text{ m}$$

$$\mathbf{T} = (50 \text{ N}) \frac{\mathbf{r}_{AB}}{|\mathbf{r}_{AB}|} = (-33.7\mathbf{i} + 36.7\mathbf{j} + 3.93\mathbf{k}) \text{ N}$$

Now take the cross product

$$\mathbf{r}_{CA} \times \mathbf{T} = \begin{vmatrix} \mathbf{i} & \mathbf{j} & \mathbf{k} \\ -0.091 & -0.137 & 0.114 \\ -33.7 & 36.7 & 3.93 \end{vmatrix} = (-4.72\mathbf{i} - 3.48\mathbf{j} + -7.96\mathbf{k}) \text{ N}\cdot\text{m}$$

$$\boxed{\mathbf{r}_{CA} \times \mathbf{T} = (-47.2\mathbf{i} - 3.48\mathbf{j} + -7.96\mathbf{k}) \text{ N}\cdot\text{m}}$$

**Problem 2.139** In Example 2.16, suppose that the attachment point  $E$  is moved to the location  $(0.3, 0.3, 0)$  m and the magnitude of  $\mathbf{T}$  increases to 600 N. What is the magnitude of the component of  $\mathbf{T}$  perpendicular to the door?

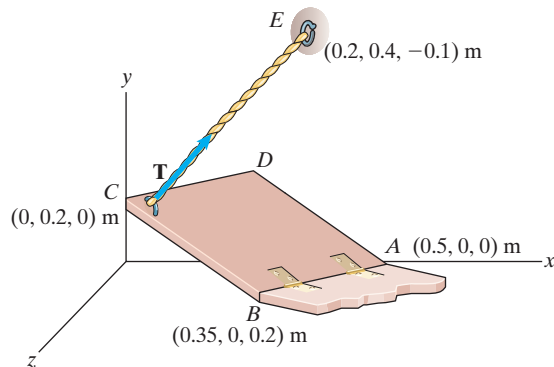

**Solution:** We first develop the force  $\mathbf{T}$ .

$$\mathbf{r}_{CE} = (0.3\mathbf{i} + 0.1\mathbf{j}) \text{ m}$$

$$\mathbf{T} = (600 \text{ N}) \frac{\mathbf{r}_{CE}}{|\mathbf{r}_{CE}|} = (569\mathbf{i} + 190\mathbf{j}) \text{ N}$$

From Example 2.16 we know that the unit vector perpendicular to the door is

$$\mathbf{e} = (0.358\mathbf{i} + 0.894\mathbf{j} + 0.268\mathbf{k})$$

The magnitude of the force perpendicular to the door (parallel to  $\mathbf{e}$ ) is then

$$|\mathbf{T}_n| = \mathbf{T} \cdot \mathbf{e} = (569 \text{ N})(0.358) + (190 \text{ N})(0.894) = 373 \text{ N}$$

$$\boxed{|\mathbf{T}_n| = 373 \text{ N}}$$

**Problem 2.140** The bar  $AB$  is 6 m long and is perpendicular to the bars  $AC$  and  $AD$ . Use the cross product to determine the coordinates  $x_B$ ,  $y_B$ ,  $z_B$  of point  $B$ .

**Solution:** The strategy is to determine the unit vector perpendicular to both  $AC$  and  $AD$ , and then determine the coordinates that will agree with the magnitude of  $AB$ . The position vectors are:

$$\mathbf{r}_{OA} = 0\mathbf{i} + 3\mathbf{j} + 0\mathbf{k}, \mathbf{r}_{OD} = 0\mathbf{i} + 0\mathbf{j} + 3\mathbf{k}, \text{ and}$$

$$\mathbf{r}_{OC} = 4\mathbf{i} + 0\mathbf{j} + 0\mathbf{k}. \text{ The vectors collinear with the bars are:}$$

$$\mathbf{r}_{AD} = (0 - 0)\mathbf{i} + (0 - 3)\mathbf{j} + (3 - 0)\mathbf{k} = 0\mathbf{i} - 3\mathbf{j} + 3\mathbf{k},$$

$$\mathbf{r}_{AC} = (4 - 0)\mathbf{i} + (0 - 3)\mathbf{j} + (0 - 0)\mathbf{k} = 4\mathbf{i} - 3\mathbf{j} + 0\mathbf{k}.$$

The vector collinear with  $\mathbf{r}_{AB}$  is

$$\mathbf{R} = \mathbf{r}_{AD} \times \mathbf{r}_{AC} = \begin{vmatrix} \mathbf{i} & \mathbf{j} & \mathbf{k} \\ 0 & -3 & 3 \\ 4 & -3 & 0 \end{vmatrix} = 9\mathbf{i} + 12\mathbf{j} + 12\mathbf{k}$$

The magnitude  $|\mathbf{R}| = 19.21$  (m). The unit vector is

$$\mathbf{e}_{AB} = \frac{\mathbf{R}}{|\mathbf{R}|} = 0.4685\mathbf{i} + 0.6247\mathbf{j} + 0.6247\mathbf{k}.$$

Thus the vector collinear with  $AB$  is

$$\mathbf{r}_{AB} = 6\mathbf{e}_{AB} = +2.811\mathbf{i} + 3.75\mathbf{j} + 3.75\mathbf{k}.$$

Using the coordinates of point  $A$ :

$$x_B = 2.81 + 0 = 2.81 \text{ (m)}$$

$$y_B = 3.75 + 3 = 6.75 \text{ (m)}$$

$$z_B = 3.75 + 0 = 3.75 \text{ (m)}$$

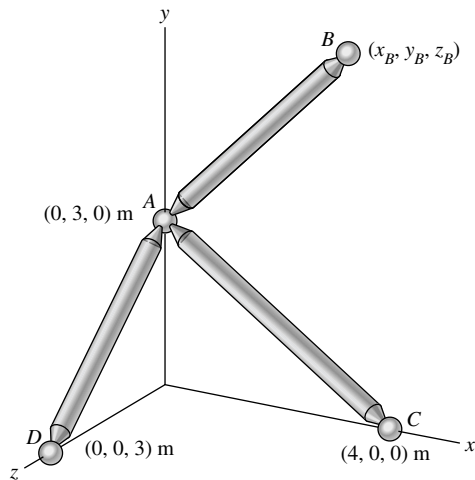

**Problem 2.141\*** Determine the minimum distance from point  $P$  to the plane defined by the three points  $A$ ,  $B$ , and  $C$ .

**Solution:** The strategy is to find the unit vector perpendicular to the plane. The projection of this unit vector on the vector  $OP$ :  $\mathbf{r}_{OP} \cdot \mathbf{e}$  is the distance from the origin to  $P$  along the perpendicular to the plane. The projection on  $\mathbf{e}$  of any vector into the plane ( $\mathbf{r}_{OA} \cdot \mathbf{e}$ ,  $\mathbf{r}_{OB} \cdot \mathbf{e}$ , or  $\mathbf{r}_{OC} \cdot \mathbf{e}$ ) is the distance from the origin to the plane along this same perpendicular. Thus the distance of  $P$  from the plane is

$$d = \mathbf{r}_{OP} \cdot \mathbf{e} - \mathbf{r}_{OA} \cdot \mathbf{e}.$$

The position vectors are:  $\mathbf{r}_{OA} = 3\mathbf{i}$ ,  $\mathbf{r}_{OB} = 5\mathbf{j}$ ,  $\mathbf{r}_{OC} = 4\mathbf{k}$  and  $\mathbf{r}_{OP} = 9\mathbf{i} + 6\mathbf{j} + 5\mathbf{k}$ . The unit vector perpendicular to the plane is found from the cross product of any two vectors lying in the plane. Noting:  $\mathbf{r}_{BC} = \mathbf{r}_{OC} - \mathbf{r}_{OB} = -5\mathbf{j} + 4\mathbf{k}$ , and  $\mathbf{r}_{BA} = \mathbf{r}_{OA} - \mathbf{r}_{OB} = 3\mathbf{i} - 5\mathbf{j}$ . The cross product:

$$\mathbf{r}_{BC} \times \mathbf{r}_{BA} = \begin{vmatrix} \mathbf{i} & \mathbf{j} & \mathbf{k} \\ 0 & -5 & 4 \\ 3 & -5 & 0 \end{vmatrix} = 20\mathbf{i} + 12\mathbf{j} + 15\mathbf{k}.$$

The magnitude is  $|\mathbf{r}_{BC} \times \mathbf{r}_{BA}| = 27.73$ , thus the unit vector is  $\mathbf{e} = 0.7212\mathbf{i} + 0.4327\mathbf{j} + 0.5409\mathbf{k}$ . The distance of point  $P$  from the plane is  $d = \mathbf{r}_{OP} \cdot \mathbf{e} - \mathbf{r}_{OA} \cdot \mathbf{e} = 11.792 - 2.164 = 9.63$  m. The second term is the distance of the plane from the origin; the vectors  $\mathbf{r}_{OB}$ , or  $\mathbf{r}_{OC}$  could have been used instead of  $\mathbf{r}_{OA}$ .

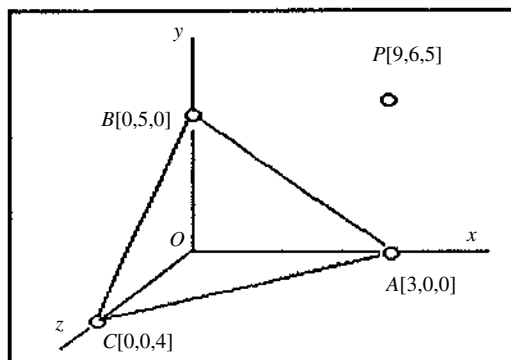
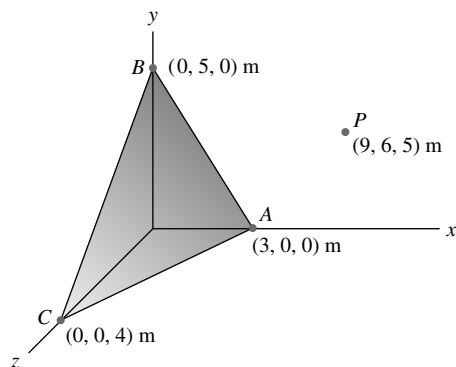

**Problem 2.142\*** The force vector  $\mathbf{F}$  points along the straight line from point  $A$  to point  $B$ . Use Eqs. (2.28)–(2.31) to prove that

$$\mathbf{r}_B \times \mathbf{F} = \mathbf{r}_A \times \mathbf{F}.$$

**Strategy:** Let  $\mathbf{r}_{AB}$  be the position vector from point  $A$  to point  $B$ . Express  $\mathbf{r}_B$  in terms of  $\mathbf{r}_A$  and  $\mathbf{r}_{AB}$ . Notice that the vectors  $\mathbf{r}_{AB}$  and  $\mathbf{F}$  are parallel.

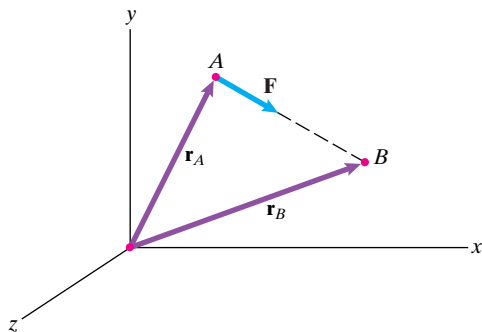

**Solution:** We have

$$\mathbf{r}_B = \mathbf{r}_A + \mathbf{r}_{AB}.$$

Therefore

$$\mathbf{r}_B \times \mathbf{F} = (\mathbf{r}_A + \mathbf{r}_{AB}) \times \mathbf{F} = \mathbf{r}_A \times \mathbf{F} + \mathbf{r}_{AB} \times \mathbf{F}$$

The last term is zero since  $\mathbf{r}_{AB} \parallel \mathbf{F}$ .

Therefore

$$\boxed{\mathbf{r}_B \times \mathbf{F} = \mathbf{r}_A \times \mathbf{F}}$$

**Problem 2.143** For the vectors  $\mathbf{U} = 6\mathbf{i} + 2\mathbf{j} - 4\mathbf{k}$ ,  $\mathbf{V} = 2\mathbf{i} + 7\mathbf{j}$ , and  $\mathbf{W} = 3\mathbf{i} + 2\mathbf{k}$ , evaluate the following mixed triple products: (a)  $\mathbf{U} \cdot (\mathbf{V} \times \mathbf{W})$ ; (b)  $\mathbf{W} \cdot (\mathbf{V} \times \mathbf{U})$ ; (c)  $\mathbf{V} \cdot (\mathbf{W} \times \mathbf{U})$ .

**Solution:** Use Eq. (2.36).

$$(a) \mathbf{U} \cdot (\mathbf{V} \times \mathbf{W}) = \begin{vmatrix} 6 & 2 & -4 \\ 2 & 7 & 0 \\ 3 & 0 & 2 \end{vmatrix}$$

$$= 6(14) - 2(4) + (-4)(-21) = 160$$

$$(b) \mathbf{W} \cdot (\mathbf{V} \times \mathbf{U}) = \begin{vmatrix} 3 & 0 & 2 \\ 2 & 7 & 0 \\ 6 & 2 & -4 \end{vmatrix}$$

$$= 3(-28) - (0) + 2(4 - 42) = -160$$

$$(c) \mathbf{V} \cdot (\mathbf{W} \times \mathbf{U}) = \begin{vmatrix} 2 & 7 & 0 \\ 3 & 0 & 2 \\ 6 & 2 & -4 \end{vmatrix}$$

$$= 2(-4) - 7(-12 - 12) + (0) = 160$$

**Problem 2.144** Use the mixed triple product to calculate the volume of the parallelepiped.

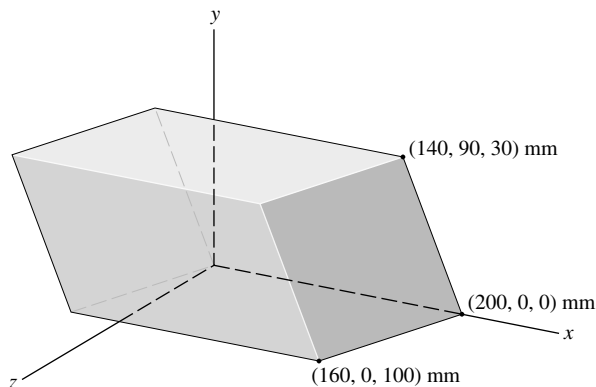

**Solution:** We are given the coordinates of point  $D$ . From the geometry, we need to locate points  $A$  and  $C$ . The key to doing this is to note that the length of side  $OD$  is 200 mm and that side  $OD$  is the  $x$  axis. Sides  $OD$ ,  $AE$ , and  $CG$  are parallel to the  $x$  axis and the coordinates of the point pairs ( $O$  and  $D$ ), ( $A$  and  $E$ ), and ( $C$  and  $D$ ) differ only by 200 mm in the  $x$  coordinate. Thus, the coordinates of point  $A$  are  $(-60, 90, 30)$  mm and the coordinates of point  $C$  are  $(-40, 0, 100)$  mm. Thus, the vectors  $\mathbf{r}_{OA}$ ,  $\mathbf{r}_{OD}$ , and  $\mathbf{r}_{OC}$  are  $\mathbf{r}_{OD} = 200\mathbf{i}$  mm,  $\mathbf{r}_{OA} = -60\mathbf{i} + 90\mathbf{j} + 30\mathbf{k}$  mm, and  $\mathbf{r}_{OC} = -40\mathbf{i} + 0\mathbf{j} + 100\mathbf{k}$  mm. The mixed triple product of the three vectors is the volume of the parallelepiped. The volume is

$$\begin{aligned} \mathbf{r}_{OA} \cdot (\mathbf{r}_{OC} \times \mathbf{r}_{OD}) &= \begin{vmatrix} -60 & 90 & 30 \\ -40 & 0 & 100 \\ 200 & 0 & 0 \end{vmatrix} \\ &= -60(0) + 90(200)(100) + (30)(0) \text{ mm}^3 \\ &= 1,800,000 \text{ mm}^3 \end{aligned}$$

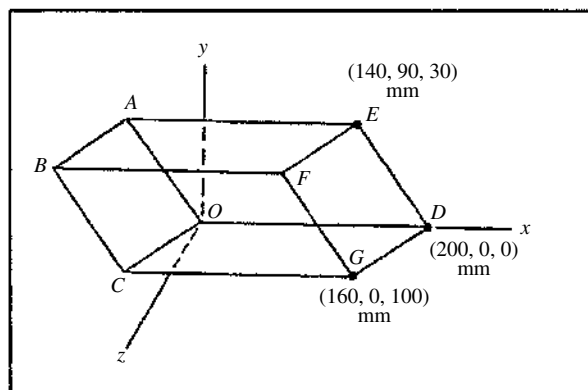

**Problem 2.145** By using Eqs. (2.23) and (2.34), show that

$$\mathbf{U} \cdot (\mathbf{V} \times \mathbf{W}) = \begin{vmatrix} U_x & U_y & U_z \\ V_x & V_y & V_z \\ W_x & W_y & W_z \end{vmatrix}$$

**Solution:** One strategy is to expand the dot product in terms of its components, take the dot product, and then collapse the expansion. Eq. (2.23) is an expansion of the dot product: Eq. (2.23):  $\mathbf{U} \cdot \mathbf{V} = U_x V_x + U_y V_y + U_z V_z$ . Eq. (2.34) is the determinant representation of the cross product:

$$\text{Eq. (2.34)} \quad \mathbf{U} \times \mathbf{V} = \begin{vmatrix} \mathbf{i} & \mathbf{j} & \mathbf{k} \\ U_x & U_y & U_z \\ V_x & V_y & V_z \end{vmatrix}$$

For notational convenience, write  $\mathbf{P} = (\mathbf{U} \times \mathbf{V})$ . Expand the determinant about its first row:

$$\mathbf{P} = \mathbf{i} \begin{vmatrix} U_y & U_z \\ V_y & V_z \end{vmatrix} - \mathbf{j} \begin{vmatrix} U_x & U_z \\ V_x & V_z \end{vmatrix} + \mathbf{k} \begin{vmatrix} U_x & U_y \\ V_x & V_y \end{vmatrix}$$

Since the two-by-two determinants are scalars, this can be written in the form:  $\mathbf{P} = \mathbf{i}P_x + \mathbf{j}P_y + \mathbf{k}P_z$  where the scalars  $P_x$ ,  $P_y$ , and  $P_z$  are the two-by-two determinants. Apply Eq. (2.23) to the dot product of a vector  $\mathbf{Q}$  with  $\mathbf{P}$ . Thus  $\mathbf{Q} \cdot \mathbf{P} = Q_x P_x + Q_y P_y + Q_z P_z$ . Substitute  $P_x$ ,  $P_y$ , and  $P_z$  into this dot product

$$\mathbf{Q} \cdot \mathbf{P} = Q_x \begin{vmatrix} U_y & U_z \\ V_y & V_z \end{vmatrix} - Q_y \begin{vmatrix} U_x & U_z \\ V_x & V_z \end{vmatrix} + Q_z \begin{vmatrix} U_x & U_y \\ V_x & V_y \end{vmatrix}$$

But this expression can be collapsed into a three-by-three determinant directly, thus:

$$\mathbf{Q} \cdot (\mathbf{U} \times \mathbf{V}) = \begin{vmatrix} Q_x & Q_y & Q_z \\ U_x & U_y & U_z \\ V_x & V_y & V_z \end{vmatrix}. \text{ This completes the demonstration.}$$

**Problem 2.146** The vectors  $\mathbf{U} = \mathbf{i} + U_y\mathbf{j} + 4\mathbf{k}$ ,  $\mathbf{V} = 2\mathbf{i} + \mathbf{j} - 2\mathbf{k}$ , and  $\mathbf{W} = -3\mathbf{i} + \mathbf{j} - 2\mathbf{k}$  are coplanar (they lie in the same plane). What is the component  $U_y$ ?

**Solution:** Since the non-zero vectors are coplanar, the cross product of any two will produce a vector perpendicular to the plane, and the dot product with the third will vanish, by definition of the dot product. Thus  $\mathbf{U} \cdot (\mathbf{V} \times \mathbf{W}) = 0$ , for example.

$$\begin{aligned} \mathbf{U} \cdot (\mathbf{V} \times \mathbf{W}) &= \begin{vmatrix} 1 & U_y & 4 \\ 2 & 1 & -2 \\ -3 & 1 & -2 \end{vmatrix} \\ &= 1(-2 + 2) - (U_y)(-4 - 6) + (4)(2 + 3) \\ &= +10U_y + 20 = 0 \end{aligned}$$

Thus  $U_y = -2$

**Problem 2.147** The magnitude of  $\mathbf{F}$  is 8 kN. Express  $\mathbf{F}$  in terms of scalar components.

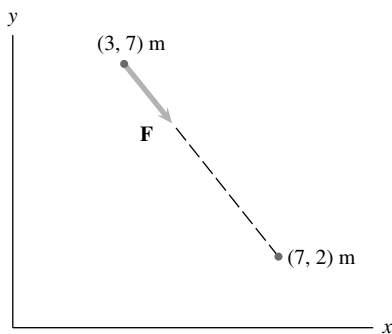

**Solution:** The unit vector collinear with the force  $\mathbf{F}$  is developed as follows: The collinear vector is  $\mathbf{r} = (7 - 3)\mathbf{i} + (2 - 7)\mathbf{j} = 4\mathbf{i} - 5\mathbf{j}$

The magnitude:  $|\mathbf{r}| = \sqrt{4^2 + 5^2} = 6.403$  m. The unit vector is

$$\mathbf{e} = \frac{\mathbf{r}}{|\mathbf{r}|} = 0.6247\mathbf{i} - 0.7809\mathbf{j}. \text{ The force vector is}$$

$$\mathbf{F} = |\mathbf{F}|\mathbf{e} = 4.998\mathbf{i} - 6.247\mathbf{j} = 5\mathbf{i} - 6.25\mathbf{j} \text{ (kN)}$$

**Problem 2.148** The magnitude of the vertical force  $\mathbf{W}$  is 600 lb, and the magnitude of the force  $\mathbf{B}$  is 1500 lb. Given that  $\mathbf{A} + \mathbf{B} + \mathbf{W} = \mathbf{0}$ , determine the magnitude of the force  $\mathbf{A}$  and the angle  $\alpha$ .

**Solution:** The strategy is to use the condition of force balance to determine the unknowns. The weight vector is  $\mathbf{W} = -600\mathbf{j}$ . The vector  $\mathbf{B}$  is

$$\mathbf{B} = 1500(\mathbf{i} \cos 50^\circ + \mathbf{j} \sin 50^\circ) = 964.2\mathbf{i} + 1149.1\mathbf{j}$$

The vector  $\mathbf{A}$  is  $\mathbf{A} = |\mathbf{A}|(\mathbf{i} \cos(180 + \alpha) + \mathbf{j} \sin(180 + \alpha))$

$\mathbf{A} = |\mathbf{A}|(-\mathbf{i} \cos \alpha - \mathbf{j} \sin \alpha)$ . The forces balance, hence  $\mathbf{A} + \mathbf{B} + \mathbf{W} = \mathbf{0}$ , or  $(964.2 - |\mathbf{A}| \cos \alpha)\mathbf{i} = \mathbf{0}$ , and  $(1149.1 - 600 - |\mathbf{A}| \sin \alpha)\mathbf{j} = \mathbf{0}$ . Thus  $|\mathbf{A}| \cos \alpha = 964.2$ , and  $|\mathbf{A}| \sin \alpha = 549.1$ . Take the ratio of the two equations to obtain  $\tan \alpha = 0.5695$ , or  $\alpha = 29.7^\circ$ . Substitute this angle to solve:  $|\mathbf{A}| = 1110$  lb

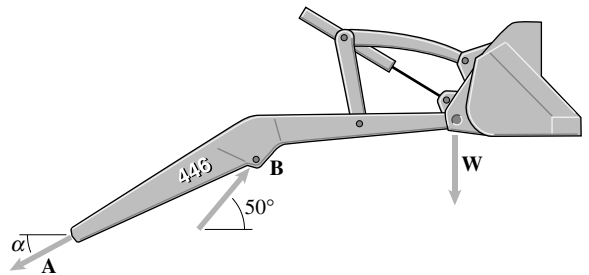

**Problem 2.149** The magnitude of the vertical force vector  $\mathbf{A}$  is 200 lb. If  $\mathbf{A} + \mathbf{B} + \mathbf{C} = \mathbf{0}$ , what are the magnitudes of the force vectors  $\mathbf{B}$  and  $\mathbf{C}$ ?

**Solution:** The strategy is to express the forces in terms of scalar components, and then solve the force balance equations for the unknowns.  $\mathbf{C} = |\mathbf{C}|(-i \cos \alpha - j \sin \alpha)$ , where

$$\tan \alpha = \frac{50}{70} = 0.7143, \text{ or } \alpha = 35.5^\circ.$$

Thus  $\mathbf{C} = |\mathbf{C}|(-0.8137i - 0.5812j)$ . Similarly,  $\mathbf{B} = +|\mathbf{B}|i$ , and  $\mathbf{A} = +200j$ . The force balance equation is  $\mathbf{A} + \mathbf{B} + \mathbf{C} = \mathbf{0}$ . Substituting,  $(-0.8137|\mathbf{C}| + |\mathbf{B}|)i = 0$ , and  $(-0.5812|\mathbf{C}| + 200)j = 0$ . Solving,  $|\mathbf{C}| = 344.1$  lb,  $|\mathbf{B}| = 280$  lb

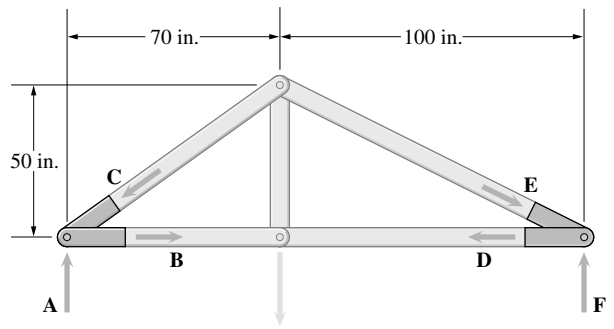

**Problem 2.150** The magnitude of the horizontal force vector  $\mathbf{D}$  in Problem 2.149 is 280 lb. If  $\mathbf{D} + \mathbf{E} + \mathbf{F} = \mathbf{0}$ , what are the magnitudes of the force vectors  $\mathbf{E}$  and  $\mathbf{F}$ ?

**Solution:** The strategy is to express the force vectors in terms of scalar components, and then solve the force balance equation for the unknowns. The force vectors are:

$$\mathbf{E} = |\mathbf{E}|(i \cos \beta - j \sin \beta), \text{ where } \tan \beta = \frac{50}{100} = 0.5, \text{ or } \beta = 26.6^\circ.$$

Thus

$$\mathbf{E} = |\mathbf{E}|(0.8944i - 0.4472j)$$

$$\mathbf{D} = -280i, \text{ and } \mathbf{F} = |\mathbf{F}|j.$$

The force balance equation is  $\mathbf{D} + \mathbf{E} + \mathbf{F} = \mathbf{0}$ . Substitute and resolve into two equations:

$$(0.8944|\mathbf{E}| - 280)i = 0, \text{ and } (-0.4472|\mathbf{E}| + |\mathbf{F}|)j = 0.$$

$$\text{Solve: } |\mathbf{E}| = 313.1 \text{ lb, } |\mathbf{F}| = 140 \text{ lb}$$

**Problem 2.151** What are the direction cosines of  $\mathbf{F}$ ?

Refer to this diagram when solving Problems 2.151–2.157.

**Solution:** Use the definition of the direction cosines and the ensuing discussion.

$$\text{The magnitude of } \mathbf{F}: |\mathbf{F}| = \sqrt{20^2 + 10^2 + 10^2} = 24.5.$$

$$\text{The direction cosines are } \cos \theta_x = \frac{F_x}{|\mathbf{F}|} = \frac{20}{24.5} = 0.8165,$$

$$\cos \theta_y = \frac{F_y}{|\mathbf{F}|} = \frac{10}{24.5} = 0.4082$$

$$\cos \theta_z = \frac{F_z}{|\mathbf{F}|} = \frac{-10}{24.5} = -0.4082$$

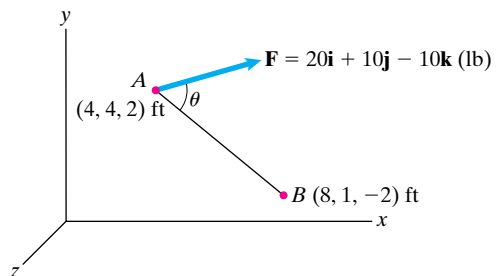

**Problem 2.152** Determine the scalar components of a unit vector parallel to line  $AB$  that points from  $A$  toward  $B$ .

**Solution:** Use the definition of the unit vector, we get

The position vectors are:  $\mathbf{r}_A = 4\mathbf{i} + 4\mathbf{j} + 2\mathbf{k}$ ,  $\mathbf{r}_B = 8\mathbf{i} + 1\mathbf{j} - 2\mathbf{k}$ . The vector from  $A$  to  $B$  is  $\mathbf{r}_{AB} = (8-4)\mathbf{i} + (1-4)\mathbf{j} + (-2-2)\mathbf{k} = 4\mathbf{i} - 3\mathbf{j} - 4\mathbf{k}$ . The magnitude:  $|\mathbf{r}_{AB}| = \sqrt{4^2 + 3^2 + 4^2} = 6.4$ . The unit vector is

$$\mathbf{e}_{AB} = \frac{\mathbf{r}_{AB}}{|\mathbf{r}_{AB}|} = \frac{4}{6.4}\mathbf{i} - \frac{3}{6.4}\mathbf{j} - \frac{4}{6.4}\mathbf{k} = 0.6247\mathbf{i} - 0.4685\mathbf{j} - 0.6247\mathbf{k}$$

**Problem 2.153** What is the angle  $\theta$  between the line  $AB$  and the force  $\mathbf{F}$ ?

**Solution:** Use the definition of the dot product Eq. (2.18), and Eq. (2.24):

$$\cos \theta = \frac{\mathbf{r}_{AB} \cdot \mathbf{F}}{|\mathbf{r}_{AB}||\mathbf{F}|}$$

From the solution to Problem 2.130, the vector parallel to  $AB$  is  $\mathbf{r}_{AB} = 4\mathbf{i} - 3\mathbf{j} - 4\mathbf{k}$ , with a magnitude  $|\mathbf{r}_{AB}| = 6.4$ . From Problem 2.151, the force is  $\mathbf{F} = 20\mathbf{i} + 10\mathbf{j} - 10\mathbf{k}$ , with a magnitude of  $|\mathbf{F}| = 24.5$ . The dot product is  $\mathbf{r}_{AB} \cdot \mathbf{F} = (4)(20) + (-3)(10) + (-4)(-10) = 90$ . Substituting,  $\cos \theta = \frac{90}{(6.4)(24.5)} = 0.574$ ,  $\theta = 55^\circ$

**Problem 2.154** Determine the vector component of  $\mathbf{F}$  that is parallel to the line  $AB$ .

**Solution:** Use the definition in Eq. (2.26):  $\mathbf{U}_P = (\mathbf{e} \cdot \mathbf{U})\mathbf{e}$ , where  $\mathbf{e}$  is parallel to a line  $L$ . From Problem 2.152 the unit vector parallel to line  $AB$  is  $\mathbf{e}_{AB} = 0.6247\mathbf{i} - 0.4688\mathbf{j} - 0.6247\mathbf{k}$ . The dot product is

$$\mathbf{e} \cdot \mathbf{F} = (0.6247)(20) + (-0.4688)(10) + (-0.6247)(-10) = 14.053.$$

The parallel vector is

$$(\mathbf{e} \cdot \mathbf{F})\mathbf{e} = (14.053)\mathbf{e} = 8.78\mathbf{i} - 6.59\mathbf{j} - 8.78\mathbf{k} \text{ (lb)}$$

**Problem 2.155** Determine the vector component of  $\mathbf{F}$  that is normal to the line  $AB$ .

**Solution:** Use the Eq. (2.27) and the solution to Problem 2.154.

$$\begin{aligned} \mathbf{F}_N &= \mathbf{F} - \mathbf{F}_P = (20 - 8.78)\mathbf{i} + (10 + 6.59)\mathbf{j} + (-10 + 8.78)\mathbf{k} \\ &= 11.22\mathbf{i} + 16.59\mathbf{j} - 1.22\mathbf{k} \text{ (lb)} \end{aligned}$$

**Problem 2.156** Determine the vector  $\mathbf{r}_{BA} \times \mathbf{F}$ , where  $\mathbf{r}_{BA}$  is the position vector from  $B$  to  $A$ .

**Solution:** Use the definition in Eq. (2.34). Noting  $\mathbf{r}_{BA} = -\mathbf{r}_{AB}$ , from Problem 2.155  $\mathbf{r}_{BA} = -4\mathbf{i} + 3\mathbf{j} + 4\mathbf{k}$ . The cross product is

$$\begin{aligned} \mathbf{r}_{BA} \times \mathbf{F} &= \begin{vmatrix} \mathbf{i} & \mathbf{j} & \mathbf{k} \\ -4 & 3 & 4 \\ 20 & 10 & -10 \end{vmatrix} = (-30 - 40)\mathbf{i} - (40 - 80)\mathbf{j} \\ &\quad + (-40 - 60) \\ &= -70\mathbf{i} + 40\mathbf{j} - 100\mathbf{k} \text{ (ft-lb)} \end{aligned}$$



**Problem 2.157** (a) Write the position vector  $\mathbf{r}_{AB}$  from point  $A$  to point  $B$  in terms of components.

(b) A vector  $\mathbf{R}$  has magnitude  $|\mathbf{R}| = 200$  lb and is parallel to the line from  $A$  to  $B$ . Write  $\mathbf{R}$  in terms of components.

**Solution:**

(a)  $\mathbf{r}_{AB} = ([8 - 4]\mathbf{i} + [1 - 4]\mathbf{j} + [-2 - 2]\mathbf{k})$  ft

$$\mathbf{r}_{AB} = (4\mathbf{i} - 3\mathbf{j} - 4\mathbf{k}) \text{ ft}$$

(b)  $\mathbf{R} = (200 \text{ N}) \frac{\mathbf{r}_{AB}}{|\mathbf{r}_{AB}|} = (125\mathbf{i} - 93.7\mathbf{j} - 125\mathbf{k})$  N

$$\mathbf{R} = (125\mathbf{i} - 96.3\mathbf{j} - 125\mathbf{k}) \text{ N}$$

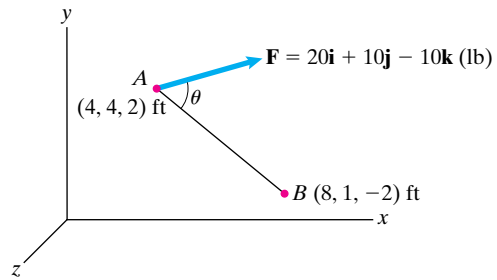

**Problem 2.158** The rope exerts a force of magnitude  $|\mathbf{F}| = 200$  lb on the top of the pole at  $B$ .

(a) Determine the vector  $\mathbf{r}_{AB} \times \mathbf{F}$ , where  $\mathbf{r}_{AB}$  is the position vector from  $A$  to  $B$ .

(b) Determine the vector  $\mathbf{r}_{AC} \times \mathbf{F}$ , where  $\mathbf{r}_{AC}$  is the position vector from  $A$  to  $C$ .

**Solution:** The strategy is to define the unit vector pointing from  $B$  to  $A$ , express the force in terms of this unit vector, and take the cross product of the position vectors with this force. The position vectors

$$\mathbf{r}_{AB} = 5\mathbf{i} + 6\mathbf{j} + 1\mathbf{k}, \quad \mathbf{r}_{AC} = 3\mathbf{i} + 0\mathbf{j} + 4\mathbf{k},$$

$$\mathbf{r}_{BC} = (3 - 5)\mathbf{i} + (0 - 6)\mathbf{j} + (4 - 1)\mathbf{k} = -2\mathbf{i} - 6\mathbf{j} + 3\mathbf{k}.$$

The magnitude  $|\mathbf{r}_{BC}| = \sqrt{2^2 + 6^2 + 3^2} = 7$ . The unit vector is

$$\mathbf{e}_{BC} = \frac{\mathbf{r}_{BC}}{|\mathbf{r}_{BC}|} = -0.2857\mathbf{i} - 0.8571\mathbf{j} + 0.4286\mathbf{k}.$$

The force vector is

$$\mathbf{F} = |\mathbf{F}|\mathbf{e}_{BC} = 200\mathbf{e}_{BC} = -57.14\mathbf{i} - 171.42\mathbf{j} + 85.72\mathbf{k}.$$

The cross products:

$$\begin{aligned} \mathbf{r}_{AB} \times \mathbf{F} &= \begin{vmatrix} \mathbf{i} & \mathbf{j} & \mathbf{k} \\ 5 & 6 & 1 \\ -57.14 & -171.42 & 85.72 \end{vmatrix} \\ &= 685.74\mathbf{i} - 485.74\mathbf{j} - 514.26\mathbf{k} \\ &= 685.7\mathbf{i} - 485.7\mathbf{j} - 514.3\mathbf{k} \text{ (ft-lb)} \end{aligned}$$

$$\begin{aligned} \mathbf{r}_{AC} \times \mathbf{F} &= \begin{vmatrix} \mathbf{i} & \mathbf{j} & \mathbf{k} \\ 3 & 0 & 4 \\ -57.14 & -171.42 & 85.72 \end{vmatrix} \\ &= 685.68\mathbf{i} - 485.72\mathbf{j} - 514.26\mathbf{k} \\ &= 685.7\mathbf{i} - 485.7\mathbf{j} - 514.3\mathbf{k} \text{ (ft-lb)} \end{aligned}$$

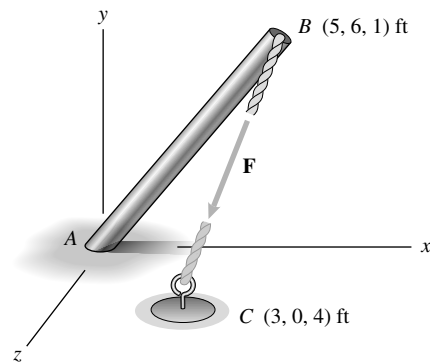

**Problem 2.159** The pole supporting the sign is parallel to the  $x$  axis and is 6 ft long. Point  $A$  is contained in the  $y$ - $z$  plane. (a) Express the vector  $\mathbf{r}$  in terms of components. (b) What are the direction cosines of  $\mathbf{r}$ ?

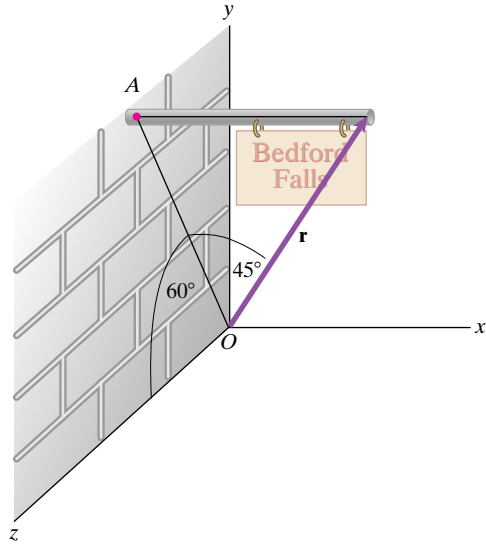

**Solution:** The vector  $\mathbf{r}$  is

$$\mathbf{r} = |\mathbf{r}|(\sin 45^\circ \mathbf{i} + \cos 45^\circ \sin 60^\circ \mathbf{j} + \cos 45^\circ \cos 60^\circ \mathbf{k})$$

The length of the pole is the  $x$  component of  $\mathbf{r}$ . Therefore

$$|\mathbf{r}| \sin 45^\circ = 6 \text{ ft} \Rightarrow |\mathbf{r}| = \frac{6 \text{ ft}}{\sin 45^\circ} = 8.49 \text{ ft}$$

(a)  $\mathbf{r} = (6.00\mathbf{i} + 5.20\mathbf{j} + 3.00\mathbf{k}) \text{ ft}$

(b) The direction cosines are

$$\cos \theta_x = \frac{r_x}{|\mathbf{r}|} = 0.707, \cos \theta_y = \frac{r_y}{|\mathbf{r}|} = 0.612, \cos \theta_z = \frac{r_z}{|\mathbf{r}|} = 0.354$$

$$\cos \theta_x = 0.707, \cos \theta_y = 0.612, \cos \theta_z = 0.354$$

**Problem 2.160** The  $z$  component of the force  $\mathbf{F}$  is 80 lb. (a) Express  $\mathbf{F}$  in terms of components. (b) what are the angles  $\theta_x$ ,  $\theta_y$ , and  $\theta_z$  between  $\mathbf{F}$  and the positive coordinate axes?

**Solution:** We can write the force as

$$\mathbf{F} = |\mathbf{F}|(\cos 20^\circ \sin 60^\circ \mathbf{i} + \sin 20^\circ \mathbf{j} + \cos 20^\circ \cos 60^\circ \mathbf{k})$$

We know that the  $z$  component is 80 lb. Therefore

$$|\mathbf{F}| \cos 20^\circ \cos 60^\circ = 80 \text{ lb} \Rightarrow |\mathbf{F}| = 170 \text{ lb}$$

(a)  $\mathbf{F} = (139\mathbf{i} + 58.2\mathbf{j} + 80\mathbf{k}) \text{ lb}$

(b) The direction cosines can be found:

$$\theta_x = \cos^{-1} \left( \frac{139}{170} \right) = 35.5^\circ$$

$$\theta_y = \cos^{-1} \left( \frac{58.2}{170} \right) = 70.0^\circ$$

$$\theta_z = \cos^{-1} \left( \frac{80}{170} \right) = 62.0^\circ$$

$$\theta_x = 35.5^\circ, \theta_y = 70.0^\circ, \theta_z = 62.0^\circ$$

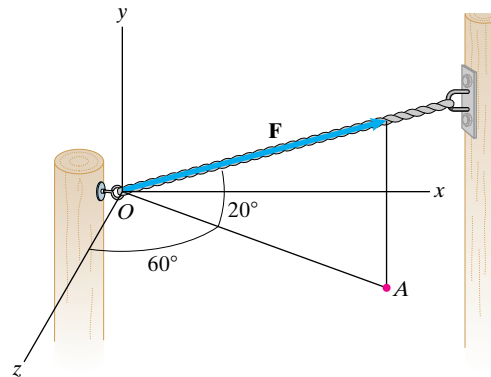

**Problem 2.161** The magnitude of the force vector  $\mathbf{F}_B$  is 2 kN. Express it in terms of scalar components.

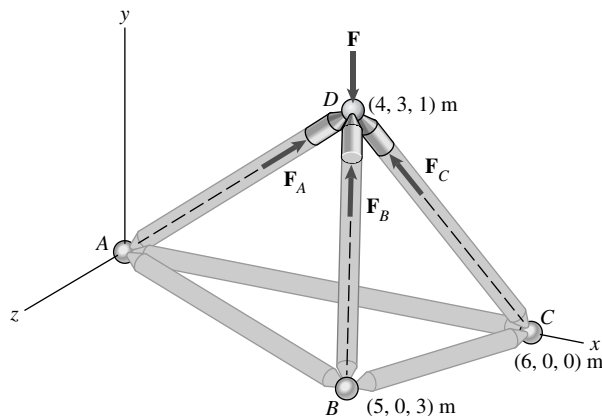

**Solution:** The strategy is to determine the unit vector collinear with  $\mathbf{F}_B$  and then express the force in terms of this unit vector.

The radius vector collinear with  $\mathbf{F}_B$  is

$$\mathbf{r}_{BD} = (4 - 5)\mathbf{i} + (3 - 0)\mathbf{j} + (1 - 3)\mathbf{k} \text{ or } \mathbf{r}_{BD} = -1\mathbf{i} + 3\mathbf{j} - 2\mathbf{k}.$$

The magnitude is

$$|\mathbf{r}_{BD}| = \sqrt{1^2 + 3^2 + 2^2} = 3.74.$$

The unit vector is

$$\mathbf{e}_{BD} = \frac{\mathbf{r}_{BD}}{|\mathbf{r}_{BD}|} = -0.2673\mathbf{i} + 0.8018\mathbf{j} - 0.5345\mathbf{k}$$

The force is

$$\begin{aligned} \mathbf{F}_B &= |\mathbf{F}_B|\mathbf{e}_{BD} = 2\mathbf{e}_{BD} \text{ (kN)} \quad \mathbf{F}_B = -0.5345\mathbf{i} + 1.6036\mathbf{j} - 1.0693\mathbf{k} \\ &= -0.53\mathbf{i} + 1.60\mathbf{j} - 1.07\mathbf{k} \text{ (kN)} \end{aligned}$$

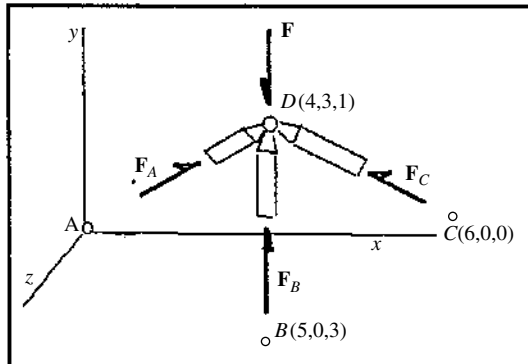

**Problem 2.162** The magnitude of the vertical force vector  $\mathbf{F}$  in Problem 2.161 is 6 kN. Determine the vector components of  $\mathbf{F}$  parallel and normal to the line from  $B$  to  $D$ .

**Solution:** The projection of the force  $\mathbf{F}$  onto the line from  $B$  to  $D$  is  $\mathbf{F}_P = (\mathbf{F} \cdot \mathbf{e}_{BD})\mathbf{e}_{BD}$ . The vertical force has the component  $\mathbf{F} = -6\mathbf{j}$  (kN). From Problem 2.139, the unit vector pointing from  $B$  to  $D$  is  $\mathbf{e}_{BD} = -0.2673\mathbf{i} + 0.8018\mathbf{j} - 0.5345\mathbf{k}$ . The dot product is  $\mathbf{F} \cdot \mathbf{e}_{BD} = -4.813$ . Thus the component parallel to the line  $BD$  is  $\mathbf{F}_P = -4.813\mathbf{e}_{BD} = +1.29\mathbf{i} - 3.86\mathbf{j} + 2.57\mathbf{k}$  (kN). The component perpendicular to the line is:  $\mathbf{F}_N = \mathbf{F} - \mathbf{F}_P$ . Thus  $\mathbf{F}_N = -1.29\mathbf{i} - 2.14\mathbf{j} - 2.57\mathbf{k}$  (kN)

**Problem 2.163** The magnitude of the vertical force vector  $\mathbf{F}$  in Problem 2.161 is 6 kN. Given that  $\mathbf{F} + \mathbf{F}_A + \mathbf{F}_B + \mathbf{F}_C = 0$ , what are the magnitudes of  $\mathbf{F}_A$ ,  $\mathbf{F}_B$ , and  $\mathbf{F}_C$ ?

**Solution:** The strategy is to expand the forces into scalar components, and then use the force balance equation to solve for the unknowns. The unit vectors are used to expand the forces into scalar components. The position vectors, magnitudes, and unit vectors are:

$$\mathbf{r}_{AD} = 4\mathbf{i} + 3\mathbf{j} + 1\mathbf{k}, \quad |\mathbf{r}_{AD}| = \sqrt{26} = 5.1,$$

$$\mathbf{e}_{AD} = 0.7845\mathbf{i} + 0.5883\mathbf{j} + 0.1961\mathbf{k}.$$

$$\mathbf{r}_{BD} = -1\mathbf{i} + 3\mathbf{j} - 2\mathbf{k}, \quad |\mathbf{r}_{BD}| = \sqrt{14} = 3.74,$$

$$\mathbf{e}_{BD} = -0.2673\mathbf{i} + 0.8018\mathbf{j} - 0.5345\mathbf{k}.$$

$$\mathbf{r}_{CD} = -2\mathbf{i} + 3\mathbf{j} + 1\mathbf{k}, \quad |\mathbf{r}_{CD}| = \sqrt{14} = 3.74,$$

$$\mathbf{e}_{CD} = -0.5345\mathbf{i} + 0.8018\mathbf{j} + 0.2673\mathbf{k}$$

The forces are:

$$\mathbf{F}_A = |\mathbf{F}_A|\mathbf{e}_{AD}, \quad \mathbf{F}_B = |\mathbf{F}_B|\mathbf{e}_{BD}, \quad \mathbf{F}_C = |\mathbf{F}_C|\mathbf{e}_{CD}, \quad \mathbf{F} = -6\mathbf{j} \text{ (kN)}.$$

Substituting into the force balance equation

$$\mathbf{F} + \mathbf{F}_A + \mathbf{F}_B + \mathbf{F}_C = 0,$$

$$(0.7843|\mathbf{F}_A| - 0.2674|\mathbf{F}_B| - 0.5348|\mathbf{F}_C|)\mathbf{i} = 0$$

$$(0.5882|\mathbf{F}_A| + 0.8021|\mathbf{F}_B| + 0.8021|\mathbf{F}_C| - 6)\mathbf{j}$$

$$= 0(0.1961|\mathbf{F}_A| - 0.5348|\mathbf{F}_B| + 0.2674|\mathbf{F}_C|)\mathbf{k} = 0$$

These simple simultaneous equations can be solved a standard method (e.g., Gauss elimination) or, conveniently, by using a commercial package, such as TK Solver®, Mathcad®, or other. An HP-28S hand held calculator was used here:  $|\mathbf{F}_A| = 2.83$  (kN),  $|\mathbf{F}_B| = 2.49$  (kN),  $|\mathbf{F}_C| = 2.91$  (kN)

**Problem 2.164** The magnitude of the vertical force  $\mathbf{W}$  is 160 N. The direction cosines of the position vector from  $A$  to  $B$  are  $\cos \theta_x = 0.500$ ,  $\cos \theta_y = 0.866$ , and  $\cos \theta_z = 0$ , and the direction cosines of the position vector from  $B$  to  $C$  are  $\cos \theta_x = 0.707$ ,  $\cos \theta_y = 0.619$ , and  $\cos \theta_z = -0.342$ . Point  $G$  is the midpoint of the line from  $B$  to  $C$ . Determine the vector  $\mathbf{r}_{AG} \times \mathbf{W}$ , where  $\mathbf{r}_{AG}$  is the position vector from  $A$  to  $G$ .

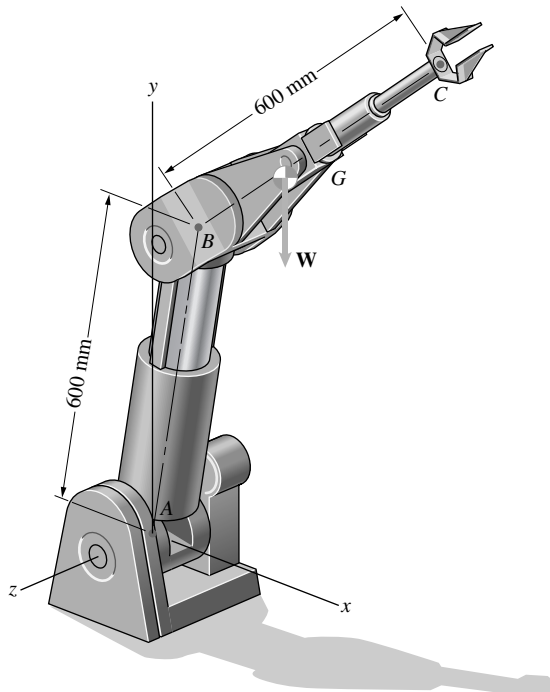

**Solution:** Express the position vectors in terms of scalar components, calculate  $\mathbf{r}_{AG}$ , and take the cross product. The position vectors are:  $\mathbf{r}_{AB} = 0.6(.5\mathbf{i} + 0.866\mathbf{j} + 0\mathbf{k})$ ,  $\mathbf{r}_{BC} = 0.3(.707\mathbf{i} + 0.619\mathbf{j} - 0.342\mathbf{k})$ , and  $\mathbf{W} = -160\mathbf{j}$

$$\mathbf{r}_{BG} = 0.3(0.707\mathbf{i} + 0.619\mathbf{j} - 0.342\mathbf{k}),$$

$$\mathbf{r}_{AG} = 0.2121\mathbf{i} + 0.1857\mathbf{j} - 0.1026\mathbf{k}.$$

$$\mathbf{r}_{AG} = \mathbf{r}_{AB} + \mathbf{r}_{BG} = 0.5121\mathbf{i} + 0.7053\mathbf{j} - 0.1026\mathbf{k}.$$

$$\mathbf{W} = -160\mathbf{j}$$

$$\mathbf{r}_{AG} \times \mathbf{W} = \begin{vmatrix} \mathbf{i} & \mathbf{j} & \mathbf{k} \\ 0.5121 & 0.7053 & -0.1026 \\ 0 & -160 & 0 \end{vmatrix}$$

$$= -16.44\mathbf{i} + 0\mathbf{j} - 81.95\mathbf{k} = -16.4\mathbf{i} + 0\mathbf{j} - 82\mathbf{k} \text{ (N m)}$$

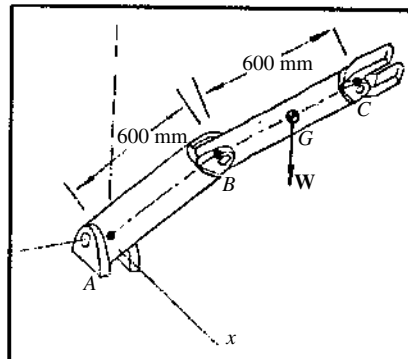

**Problem 2.165** The rope  $CE$  exerts a 500-N force  $\mathbf{T}$  on the hinged door.

- (a) Express  $\mathbf{T}$  in terms of components.  
 (b) Determine the vector component of  $\mathbf{T}$  parallel to the line from point  $A$  to point  $B$ .

**Solution:** We have

$$\mathbf{r}_{CE} = (0.2\mathbf{i} + 0.2\mathbf{j} - 0.1\mathbf{k}) \text{ m}$$

$$\mathbf{T} = (500 \text{ N}) \frac{\mathbf{r}_{CE}}{|\mathbf{r}_{CE}|} = (333\mathbf{i} + 333\mathbf{j} - 167\mathbf{k}) \text{ N}$$

(a)  $\mathbf{T} = (333\mathbf{i} + 333\mathbf{j} - 167\mathbf{k}) \text{ N}$

- (b) We define the unit vector in the direction of  $AB$  and then use this vector to find the component parallel to  $AB$ .

$$\mathbf{r}_{AB} = (-0.15\mathbf{i} + 0.2\mathbf{k}) \text{ m}$$

$$\mathbf{e}_{AB} = \frac{\mathbf{r}_{AB}}{|\mathbf{r}_{AB}|} = (-0.6\mathbf{i} + 0.8\mathbf{k})$$

$$\mathbf{T}_p = (\mathbf{e}_{AB} \cdot \mathbf{T})\mathbf{e}_{AB} = ([-0.6][333 \text{ N}] + [0.8][-167 \text{ N}])(-0.6\mathbf{i} + 0.8\mathbf{k})$$

$\mathbf{T}_p = (200\mathbf{i} - 267\mathbf{k}) \text{ N}$

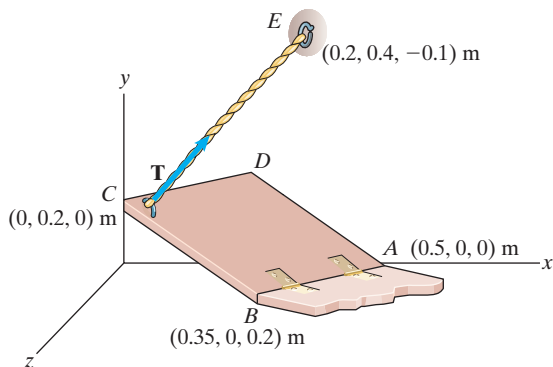

**Problem 2.166** In Problem 2.165, let  $\mathbf{r}_{BC}$  be the position vector from point  $B$  to point  $C$ . Determine the cross product  $\mathbf{r}_{BC} \times \mathbf{T}$ .

**Solution:** From Problem 2.165 we know that

$$\mathbf{T} = (333\mathbf{i} + 333\mathbf{j} - 167\mathbf{k}) \text{ N}$$

The vector  $\mathbf{r}_{BC}$  is

$$\mathbf{r}_{BC} = (-0.35\mathbf{i} + 0.2\mathbf{j} - 0.2\mathbf{k}) \text{ m}$$

The cross product is

$$\mathbf{r}_{BC} \times \mathbf{T} = \begin{vmatrix} \mathbf{i} & \mathbf{j} & \mathbf{k} \\ -0.35 & 0.2 & -0.2 \\ 333 & 333 & -137 \end{vmatrix} = (33.3\mathbf{i} - 125\mathbf{j} - 183\mathbf{k}) \text{ Nm}$$

$\mathbf{r}_{BC} \times \mathbf{T} = (33.3\mathbf{i} - 125\mathbf{j} - 183\mathbf{k}) \text{ Nm}$

