

P2 SOLUTIONS TO PROBLEMS DIELECTRICS, CAPACITANCE, AND ELECTRIC ENERGY

Section 2.3 Bound Volume and Surface Charge Densities

PROBLEM 2.1 **Nonuniformly polarized dielectric parallelepiped.** This problem is similar to Example 2.1.

(a) Combining Eqs.(2.19) and (1.167), the bound (polarization) volume charge density inside the parallelepiped is

$$\rho_p = -\nabla \cdot \mathbf{P} = -\left(\frac{\partial P_x}{\partial x} + \frac{\partial P_y}{\partial y} + \frac{\partial P_z}{\partial z}\right) = -P_0 \left(\frac{1}{a} + \frac{1}{b} + \frac{1}{c}\right), \quad (\text{P2.1})$$

so it turns out to be constant throughout the volume (v) of the body.

With Eq.(2.23) in mind, we realize that there is no bound surface charge on the parallelepiped sides belonging to planes $x = 0$, $y = 0$, and $z = 0$, respectively, since $\mathbf{P}(0^+, y, z) = \mathbf{P}(x, 0^+, z) = \mathbf{P}(x, y, 0^+) = 0$. On the sides belonging to planes $x = a$, $y = b$, and $z = c$, the bound surface charge density is given by

$$\begin{aligned} \rho_{ps1} = \hat{\mathbf{n}}_d \cdot \mathbf{P} = \hat{\mathbf{x}} \cdot \mathbf{P}(a^-, y, z) = P_0, \quad \rho_{ps2} = \hat{\mathbf{y}} \cdot \mathbf{P}(x, b^-, z) = P_0, \\ \text{and} \quad \rho_{ps3} = \hat{\mathbf{z}} \cdot \mathbf{P}(x, y, c^-) = P_0, \end{aligned} \quad (\text{P2.2})$$

respectively; hence, $\rho_{ps1} = \rho_{ps2} = \rho_{ps3} = \rho_{ps} = \text{const}$, as well, on the entire surface (S) of the parallelepiped.

(b) By means of Eqs.(1.30), (P2.1), and (P2.2),

$$Q_p = \rho_p v + \rho_{ps} S = \rho_p abc + \rho_{ps}(ab + bc + ac) = 0, \quad (\text{P2.3})$$

which confirms that the total bound charge of the dielectric parallelepiped is zero.

Section 2.4 Evaluation of the Electric Field and Potential Due to Polarized Dielectrics

PROBLEM 2.2 **Uniformly polarized disk on a conducting plane.** The distribution of bound charges of the disk is determined in Example 2.2; the volume bound charge density (ρ_p) is zero, the surface densities on the upper and lower disk bases, ρ_{ps1} and ρ_{ps2} , are those in Eqs.(2.28), while $\rho_{ps3} = 0$ on the side disk surface.

The electric field in both the disk and the air equals the field due to two circular sheets of charge with densities ρ_{ps1} and ρ_{ps2} in free space, as well as their negative images in the conducting plane in Fig.2.36. Namely, by image theory (Section 1.21),

the charges (of density ρ_{ps2}) right on the plane, at the coordinate $z = 0^+$, and their images (of density $-\rho_{ps2}$) right below the plane, at the coordinate $z = 0^-$, cancel each other, so we are left with the two circular sheets of charge (in free space) shown in Fig.P2.1.

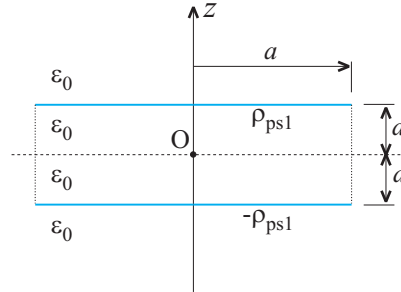

Figure P2.1 Two circular sheets of charge $\rho_{ps1} = P$ and $-\rho_{ps1} = -P$ in free space – equivalent, by virtue of image theory, to the uniformly polarized dielectric disk on a conducting plane in Fig.2.36.

Like in Eq.(2.29), we then invoke the superposition principle and the expression for the electric field due to a thin charged disk, Eq.(1.63), and obtain the total electric field vector at a point defined by the coordinate z ($0 < z < \infty$) along the z -axis in Fig.P2.1 (or Fig.2.36) as follows:

$$\mathbf{E} = \mathbf{E}_1 + \mathbf{E}_2 = \frac{P}{2\epsilon_0} \left[\frac{z-d}{|z-d|} - \frac{z-d}{\sqrt{a^2 + (z-d)^2}} - 1 + \frac{z+d}{\sqrt{a^2 + (z+d)^2}} \right] \hat{\mathbf{z}} \quad (z > 0). \quad (\text{P2.4})$$

In the conductor in the original structure, Fig.2.36, there is no electric field, so $\mathbf{E} = 0$ for $z < 0$.

PROBLEM 2.3 Uniformly polarized hollow dielectric cylinder. This is, essentially, very similar to the analysis performed in Example 2.2; the only important difference is that the two circular sheets of surface charge with densities $\rho_{ps1} = P$ and $\rho_{ps2} = -P$, which, for the electric field computation, can be considered to be in free space, now have a circular hole. The field vectors \mathbf{E}_1 and \mathbf{E}_2 in Eq.(2.29) at the center of the hollow dielectric cylinder (point O), where $\mathbf{E}_1 = \mathbf{E}_2$, are computed, therefore, as an integral of fields due to elementary rings (as in Fig.1.14), by merely changing the integration limits in Eq.(1.63) to a (starting) and b (ending). Alternatively, we can represent the hollow disk (with inner and outer radii a and b , respectively, and charge density ρ_s) as a superposition of a solid (continuous) disk (as in Fig.1.14) with radius b and charge density ρ_s and another one with radius a and charge density $-\rho_s$, use Eq.(1.63) for the fields due to each of them, and add together the results. In either way, we obtain the following expression for the total field at the point O, whose distance from the centers of each hollow disk is h (Fig.P2.2):

$$\mathbf{E} = \mathbf{E}_1 + \mathbf{E}_2 = 2\mathbf{E}_1 = -\frac{Ph}{\epsilon_0} \left[\frac{1}{\sqrt{a^2 + h^2}} - \frac{1}{\sqrt{b^2 + h^2}} \right] \hat{\mathbf{z}}. \quad (\text{P2.5})$$

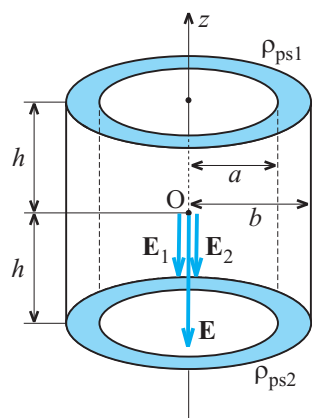

Figure P2.2 Evaluation of the electric field intensity vector at the center of a uniformly polarized hollow dielectric cylinder in Fig.2.37.

PROBLEM 2.4 Nonuniformly polarized thin dielectric disk. (a) By means of Eq.(2.19) and the formula for the divergence in cylindrical coordinates, Eq.(1.170), the bound volume charge density of the nonuniformly polarized dielectric disk in Fig.2.38 amounts to

$$\rho_p = -\nabla \cdot \mathbf{P} = -\frac{1}{r} \frac{\partial}{\partial r} (rP_r) = -\frac{2P_0}{a}. \quad (\text{P2.6})$$

From Eq.(2.23), the bound surface charge density on the lateral (cylindrical) surface of the disk is

$$\rho_{ps} = \hat{\mathbf{r}} \cdot \mathbf{P}(a^-) = P_0, \quad (\text{P2.7})$$

while $\rho_{ps} = 0$ on disk bases.

(b) Since the disk is very thin ($d \ll a$), its bound volume charge, also being uniformly distributed ($\rho_p = \text{const}$) throughout the disk volume, can be considered as an equivalent circular sheet of charge, with density $\rho_s = \rho_p d = -2P_0 d/a$; namely, the total bound volume charge of the disk, $\rho_p \pi a^2 d$, must be equal to the total surface charge of the equivalent sheet, so $\rho_s \pi a^2$, which yields this expression for ρ_s . By the same token, the belt of bound surface charge over the disk lateral surface can be approximated by an equivalent circular line charge (ring) with density $Q' = \rho_{ps} 2\pi a d / (2\pi a) = \rho_{ps} d = P_0 d$. Consequently, Eqs.(1.63) and (1.43) can be used for the electric field at the axis of an infinitely thin disk and an infinitely thin ring of charge, respectively, and, by the superposition of the two results, \mathbf{E} at the z -axis in Fig.2.38 comes out to be

$$\begin{aligned} \mathbf{E} &= \frac{\rho_s}{2\epsilon_0} \left(\frac{z}{|z|} - \frac{z}{\sqrt{a^2 + z^2}} \right) \hat{\mathbf{z}} + \frac{Q' a z}{2\epsilon_0 (z^2 + a^2)^{3/2}} \hat{\mathbf{z}} \\ &= -\frac{P_0 d}{\epsilon_0 a} \left[\left(\frac{z}{|z|} - \frac{z}{\sqrt{a^2 + z^2}} \right) - \frac{a^2 z}{2(z^2 + a^2)^{3/2}} \right] \hat{\mathbf{z}} \quad (-\infty < z < \infty). \end{aligned} \quad (\text{P2.8})$$

PROBLEM 2.5 Uniformly polarized dielectric hemisphere. (a) The bound surface charge density at the bottom (flat) surface of the polarized hemisphere is that in Eqs.(2.28) – the second expression, and ρ_{ps} at the upper (spherical) surface in Fig.2.39 is given by Eq.(2.30), so $\rho_{ps} = P \cos \theta$, where now $0 \leq \theta \leq \pi/2$.

(b) We remove the conducting plane in Fig.2.39 using the image theory. The circular sheet of bound surface charge right against the plane and its negative image cancel each other. The hemispherical sheet, considered to be in a vacuum, is supplemented with another hemispherical sheet below the plane of symmetry, which is also described by the function in Eq.(2.30), but with $\pi/2 \leq \theta \leq \pi$ (note that the function $\cos \theta$ is antisymmetrical with respect to $\theta = \pi/2$, which corresponds to a negative image of the charge, exactly as required by the image theory). We thus obtain the full spherical sheet of bound charge in Eq.(2.30), and conclude that the polarized hemisphere on the conducting plane is equivalent to the polarized sphere of Fig.2.7, in free space. Hence, the electric field intensity vector at the point O in Fig.2.39 is given by $\mathbf{E} = -\mathbf{P}/(3\epsilon_0)$, Eq.(2.32).

PROBLEM 2.6 Nonuniformly polarized large dielectric slab. (a) Referring to Fig.P2.3 and employing Eqs.(2.19), (1.167), and (2.23), the bound volume and surface charge densities of the dielectric slab are given by

$$\rho_p = -\frac{\partial P_x}{\partial x} = -\frac{2P_0x}{a^2}, \quad \rho_{ps1} = \hat{\mathbf{x}} \cdot \mathbf{P}(a^-) = P_0, \quad \rho_{ps2} = -\hat{\mathbf{x}} \cdot \mathbf{P}(-a^+) = -P_0. \quad (\text{P2.9})$$

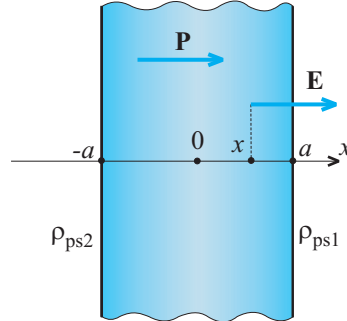

Figure P2.3 Evaluation of the bound charges and electric field of the infinitely large nonuniformly polarized dielectric slab in Fig.2.40.

(b) We note that the volume charge distribution described by $\rho_p(x)$ in Eqs.(P2.9) is the same as that in Eq.(1.153), the difference being only the different multiplicative constants. The electric field due to this charge, considered to be in free space, is therefore given by Eqs.(1.155) and (1.154), with the adjustment of constants. On the other side, the electric field due to two parallel oppositely charged sheets of densities ρ_{ps1} and ρ_{ps2} in Eqs.(P2.9) and Fig.P2.3, obtained using Eq.(1.64) or the result of Problem 1.60, amounts to $(-\rho_{ps1}/\epsilon_0)\hat{\mathbf{x}}$. By the superposition of these fields, the resultant field in Fig.P2.3 comes out to be

$$\mathbf{E}(x) = \frac{-P_0}{\epsilon_0 a^2} (x^2 - a^2) \hat{\mathbf{x}} + \frac{-P_0}{\epsilon_0} \hat{\mathbf{x}} = -\frac{P_0 x^2}{\epsilon_0 a^2} \hat{\mathbf{x}} \quad (|x| < a); \quad \mathbf{E}(x) = 0 \quad (|x| > a). \quad (\text{P2.10})$$

(c) The voltage across the slab is

$$V = \int_{x=-a}^a E(x) dx = -\frac{P_0}{\epsilon_0 a^2} \int_{-a}^a x^2 dx = -\frac{2P_0 a}{3\epsilon_0}. \quad (\text{P2.11})$$

Section 2.5 Generalized Gauss' Law

PROBLEM 2.7 Electric flux density vector. (a) Combining Eqs.(2.41) and (2.32), the electric flux density vector at the center (point O) of the polarized dielectric sphere in Fig.2.7 turns out to be

$$\mathbf{D} = \epsilon_0 \mathbf{E} + \mathbf{P} = -\frac{\mathbf{P}}{3} + \mathbf{P} = \frac{2\mathbf{P}}{3}. \quad (\text{P2.12})$$

(b) To find the vector \mathbf{D} along the axis (z -axis) of the polarized dielectric disk lying on a conducting plane in Fig.2.36, we apply Eq.(2.41) for points inside the dielectric, for $0 < z < d$, where $|z - d| = -(z - d)$ and $(z - d)/|z - d| = -1$ in the electric field expression from Problem 2.2, and obtain

$$\mathbf{D} = \epsilon_0 \mathbf{E} + \mathbf{P} = \frac{\mathbf{P}}{2} \left[-\frac{z - d}{\sqrt{a^2 + (z - d)^2}} + \frac{z + d}{\sqrt{a^2 + (z + d)^2}} \right]. \quad (\text{P2.13})$$

For $d < z < \infty$ along the z -axis in Fig.2.36, $\mathbf{P} = 0$ and $\mathbf{D} = \epsilon_0 \mathbf{E}$ (air), as well as $|z - d| = z - d$ in the electric field expression (Problem 2.2), which gives the same expression for \mathbf{D} as in Eq.(P2.13), so it holds true for $0 < z < \infty$.

Finally, $\mathbf{D} = 0$ for $z < 0$ (below the conducting plane).

PROBLEM 2.8 Total (free plus bound) volume charge density. (a) Using Eqs.(2.45), (2.19), and (2.41), the total (free plus bound) volume charge density in the dielectric can, indeed, be expressed (in terms of the electric field intensity vector, \mathbf{E} , only) as

$$\rho_{\text{tot}} = \rho + \rho_p = \nabla \cdot \mathbf{D} + (-\nabla \cdot \mathbf{P}) = \epsilon_0 \nabla \cdot \mathbf{E} + \nabla \cdot \mathbf{P} - \nabla \cdot \mathbf{P} = \epsilon_0 \nabla \cdot \mathbf{E}. \quad (\text{P2.14})$$

(b) By means of the above expression and the formula for the divergence in Cartesian coordinates, Eq.(1.167), ρ_{tot} for the given function $\mathbf{E}(x, y, z)$ comes out to be

$$\rho_{\text{tot}} = \epsilon_0 \left(\frac{\partial E_x}{\partial x} + \frac{\partial E_y}{\partial y} + \frac{\partial E_z}{\partial z} \right) = 8.85 (4yz - 3y^2 + 3z^2) \text{ pC/m}^3 \quad (y, z \text{ in m}). \quad (\text{P2.15})$$

PROBLEM 2.9 Uniform field in a dielectric. From the relationship $\rho + \rho_p = \varepsilon_0 \nabla \cdot \mathbf{E}$ (previous problem) and the fact that the divergence of the electric field vector in this dielectric region (\mathbf{E}) is zero, since the field is uniform, the bound volume charge density (ρ_p) in the region equals the negative of the free volume charge density (ρ) at the same point, namely,

$$\rho_p = \varepsilon_0 \nabla \cdot \mathbf{E} - \rho = -\rho \quad (\mathbf{E} = \text{const}) . \quad (\text{P2.16})$$

PROBLEM 2.10 Closed surface in a uniform field. Applying Gauss' law, Eq.(1.133), to the closed surface S in Fig.2.41, over which the electric field vector is constant (uniform electric field in the region), and can thus be taken out of the flux integral, and inside which there is no charge (charge-free region), we obtain

$$\oint_S \mathbf{E} \cdot d\mathbf{S} = \frac{Q_S}{\varepsilon_0} \quad \longrightarrow \quad \mathbf{E} \cdot \oint_S d\mathbf{S} = 0 \quad (\mathbf{E} = \text{const}, \quad Q_S = 0) . \quad (\text{P2.17})$$

We can rotate the parallel-plate capacitor in Fig.2.41, together with its (uniform) field, in an arbitrary way around the surface S , which is fixed, so that the vector (result of the integration) $\oint_S d\mathbf{S}$ does not change. Hence, the resulting relationship in Eq.(P2.17) is satisfied (the dot product is zero) for an arbitrary direction of the vector \mathbf{E} and a fixed vector $\oint_S d\mathbf{S}$. This is possible only if

$$\oint_S d\mathbf{S} = 0 , \quad (\text{P2.18})$$

which concludes our proof of this vector identity.

PROBLEM 2.11 Flux of the electric field intensity vector. With the use of Eqs.(2.41) and (2.44), the flux of \mathbf{E} through a closed surface S situated entirely inside the polarized dielectric body can be expressed as

$$\Psi_E = \oint_S \mathbf{E} \cdot d\mathbf{S} = \frac{1}{\varepsilon_0} \left(\oint_S \mathbf{D} \cdot d\mathbf{S} - \oint_S \mathbf{P} \cdot d\mathbf{S} \right) = \frac{1}{\varepsilon_0} \left(\int_v \rho \, dv - \oint_S \mathbf{P} \cdot d\mathbf{S} \right) , \quad (\text{P2.19})$$

where v denotes the volume enclosed by S .

Section 2.8 Electrostatic Field in Linear, Isotropic, and Homogeneous Media

PROBLEM 2.12 Total enclosed bound and free charge. Combining Eqs.(2.41), (2.47), (2.16), and (2.43), we obtain, similarly to Eqs.(2.60) and (2.61), the following relationship between the total bound charge Q_{pS} and free charge Q_S

enclosed by an imaginary closed surface S , via the permittivity ε of the homogeneous dielectric ($\varepsilon = \text{const}$):

$$\mathbf{P} = \frac{\varepsilon - \varepsilon_0}{\varepsilon} \mathbf{D} \quad \longrightarrow \quad \oint_S \mathbf{P} \cdot d\mathbf{S} = \frac{\varepsilon - \varepsilon_0}{\varepsilon} \oint_S \mathbf{D} \cdot d\mathbf{S} \quad \longrightarrow \quad Q_{pS} = -\frac{\varepsilon - \varepsilon_0}{\varepsilon} Q_S . \quad (\text{P2.20})$$

PROBLEM 2.13 Charge-free homogeneous medium. That there is no bound volume charge in a homogeneous linear medium with no free volume charge is obvious from Eq.(2.60):

$$\rho = 0 \quad \longrightarrow \quad \rho_p = -\frac{\varepsilon_r - 1}{\varepsilon_r} \rho = 0 . \quad (\text{P2.21})$$

PROBLEM 2.14 Dielectric cylinder with free volume charge. This is similar to Example 2.5 (dielectric sphere with free nonuniform volume charge).

(a) Applying the generalized Gauss' law, Eq.(2.44), to the same cylindrical Gaussian surface as in Problem 1.58 and Example 1.19, we obtain the following expression for the electric flux density in the dielectric cylinder with $\rho = \text{const}$:

$$D(r) 2\pi r h = \rho \underbrace{\pi r^2 h}_v \quad \longrightarrow \quad D(r) = \frac{\rho r}{2} \quad (0 \leq r \leq a) . \quad (\text{P2.22})$$

Having then in mind Eq.(2.47), the voltage between the axis and the surface of the cylinder amounts to

$$V = \int_{r=0}^a E(r) dr = \frac{1}{\varepsilon_r \varepsilon_0} \int_0^a D(r) dr = \frac{\rho a^2}{4\varepsilon_r \varepsilon_0} . \quad (\text{P2.23})$$

(b) As in Eqs.(2.67) and (2.68), the bound volume charge density inside the cylinder and surface charge density on its surface [note that the polarization vector is zero outside the cylinder, Eq.(2.21)] are

$$\begin{aligned} \rho_p(r) &= -\frac{\varepsilon_r - 1}{\varepsilon_r} \rho \quad (0 \leq r < a) \quad \text{and} \quad \rho_{ps} = P(a^-) = \frac{\varepsilon_r - 1}{\varepsilon_r} D(a^-) \\ &= \frac{\rho(\varepsilon_r - 1)a}{2\varepsilon_r} , \end{aligned} \quad (\text{P2.24})$$

respectively.

PROBLEM 2.15 Linear-exponential volume charge distribution. (a) For the field (observation) points in the p -type region of the semiconductor in Fig.2.42, Eq.(2.74) now becomes

$$E_x(x) = \frac{\rho_0}{\varepsilon a} \int_{x'=-\infty}^x x' e^{x'/a} dx' = -\frac{\rho_0 a}{\varepsilon} \left(1 - \frac{x}{a}\right) e^{x/a} \quad (-\infty < x \leq 0) , \quad (\text{P2.25})$$

where the integral is solved by integration by parts [$\int x e^{-x} dx = -(1+x)e^{-x} + C$]. Similarly, in the n -type region [see Eq.(2.75)] we have

$$E_x(x) = \frac{\rho_0}{\varepsilon a} \left(\int_{-\infty}^0 x' e^{x'/a} dx' + \int_0^x x' e^{-x'/a} dx' \right) = -\frac{\rho_0 a}{\varepsilon} \left(1 + \frac{x}{a} \right) e^{-x/a} \quad (0 < x < \infty). \quad (\text{P2.26})$$

(b) Like in Eqs.(2.76) and (2.77), the potential at points in the p -type region in Fig.2.42, for the reference point at the center of the junction ($x = 0$), is found as

$$\begin{aligned} V(x) &= \int_{x'=x}^0 E_x(x') dx' = -\frac{\rho_0 a}{\varepsilon} \int_x^0 \left(1 - \frac{x'}{a} \right) e^{x'/a} dx' \\ &= \frac{\rho_0 a}{\varepsilon} \left[2a \left(e^{x/a} - 1 \right) - x e^{x/a} \right] \quad (-\infty < x \leq 0), \end{aligned} \quad (\text{P2.27})$$

and in the n -type region,

$$\begin{aligned} V(x) &= -\int_0^x E_x(x') dx' = \frac{\rho_0 a}{\varepsilon} \int_0^x \left(1 + \frac{x'}{a} \right) e^{-x'/a} dx' \\ &= \frac{\rho_0 a}{\varepsilon} \left[2a \left(1 - e^{-x/a} \right) - x e^{-x/a} \right] \quad (0 < x < \infty). \end{aligned} \quad (\text{P2.28})$$

(c) The voltage between the n -type and p -type ends (built-in voltage) of the pn junction (diode) is

$$V(x \rightarrow \infty) - V(x \rightarrow -\infty) = \frac{4\rho_0 a^2}{\varepsilon}. \quad (\text{P2.29})$$

Section 2.9 Dielectric-Dielectric Boundary Conditions

PROBLEM 2.16 Dielectric-dielectric boundary conditions. (a) From the boundary condition in Eq.(2.79), the tangential components of \mathbf{E}_1 and \mathbf{E}_2 , namely, their x - and y -components, must be the same on the two sides of the boundary (plane $z = 0$), so

$$E_{2x} = E_{1x} = 4 \text{ V/m} \quad \text{and} \quad E_{2y} = E_{1y} = -2 \text{ V/m}. \quad (\text{P2.30})$$

As there is no free surface charge on the boundary, Eq.(2.83) gives the following for the normal component (z -component) of \mathbf{E}_2 for $z = 0^-$:

$$E_{2z} = E_{2n} = \frac{\varepsilon_{r1}}{\varepsilon_{r2}} E_{1n} = \frac{\varepsilon_{r1}}{\varepsilon_{r2}} E_{1z} = 10 \text{ V/m}, \quad (\text{P2.31})$$

and hence

$$\mathbf{E}_2 = (4 \hat{\mathbf{x}} - 2 \hat{\mathbf{y}} + 10 \hat{\mathbf{z}}) \text{ V/m} \quad (\rho_s = 0). \quad (\text{P2.32})$$

(b) Now ρ_s in the plane $z = 0$ is nonzero, and we use the boundary condition in Eq.(2.85) in place of Eq.(P2.31),

$$\varepsilon_1 E_{1n} - \varepsilon_2 E_{2n} = \rho_s \quad \longrightarrow \quad E_{2z} = \frac{1}{\varepsilon_{r2}\varepsilon_0} (\varepsilon_{r1}\varepsilon_0 E_{1z} - \rho_s) = 7 \text{ V/m} , \quad (\text{P2.33})$$

which, combined with Eqs.(P2.30), results in

$$\mathbf{E}_2 = (4\hat{x} - 2\hat{y} + 7\hat{z}) \text{ V/m} \quad (\rho_s \neq 0) . \quad (\text{P2.34})$$

PROBLEM 2.17 Conductor-dielectric boundary conditions. Conductor-dielectric and conductor-free space boundary conditions in Eqs.(1.186), (2.58), and (1.190) are obtained from dielectric-dielectric boundary conditions in Eqs.(2.84) and (2.85) by specifying that $\mathbf{E}_2 = 0$ and $\mathbf{D}_2 = 0$ in the second medium (conductor) [see Eq.(1.181)] and $\mathbf{D} = \varepsilon\mathbf{E}$ or $\mathbf{D} = \varepsilon_0\mathbf{E}$ in the first medium (dielectric or free space).

PROBLEM 2.18 Water-air boundary. Marking water as medium 2 and air as medium 1 in Fig.2.11, the law of refraction of the electric field lines at the water-air boundary in Eq.(2.87) gives

$$\varepsilon_2 \gg \varepsilon_1 \quad \longrightarrow \quad \frac{\varepsilon_1}{\varepsilon_2} \approx 0 \quad \longrightarrow \quad \frac{\tan \alpha_1}{\tan \alpha_2} \approx 0 \quad \longrightarrow \quad \alpha_1 \approx 0 \quad (\alpha_2 = 45^\circ) , \quad (\text{P2.35})$$

meaning that the field lines in air are approximately normal to the water surface, which is sketched in Fig.P2.4. Note that the exact angle α_1 is

$$\alpha_1 = \arctan \left(\frac{\varepsilon_{r1}}{\varepsilon_{r2}} \tan \alpha_2 \right) = \arctan \frac{1}{80} = 0.7^\circ . \quad (\text{P2.36})$$

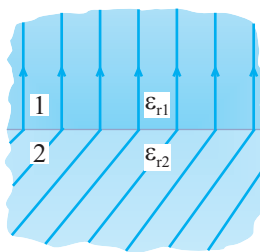

Figure P2.4 Refraction of electrostatic field lines at a water-air interface.

Section 2.10 Poisson's and Laplace's Equations

PROBLEM 2.19 Poisson's equation for inhomogeneous media. (a) Combining Eqs.(2.45), (2.47), and (1.101), we obtain the following second-order differential equation:

$$\nabla \cdot (\varepsilon \nabla V) = -\rho. \quad (\text{P2.37})$$

By means of the identity $\nabla \cdot (f\mathbf{a}) = f\nabla \cdot \mathbf{a} + (\nabla f) \cdot \mathbf{a}$ (derived in Section 3.6), it can be written also in the form

$$\varepsilon \nabla \cdot (\nabla V) + \nabla V \cdot \nabla \varepsilon = -\rho \quad \longrightarrow \quad \nabla^2 V + \frac{1}{\varepsilon} \nabla V \cdot \nabla \varepsilon = -\frac{\rho}{\varepsilon}, \quad (\text{P2.38})$$

which we refer to as Poisson's equation for an inhomogeneous medium. On the other hand, if the dielectric medium is homogeneous, $\varepsilon = \text{const}$, so that $\nabla \varepsilon = 0$, and this equation becomes Eq.(2.93), namely, the standard Poisson's equation.

(b) The version of Eq.(P2.38) for a charge-free region ($\rho = 0$), that is, Laplace's equation for an inhomogeneous medium, reads hence

$$\nabla^2 V + \frac{1}{\varepsilon} \nabla V \cdot \nabla \varepsilon = 0, \quad (\text{P2.39})$$

which, in turn, reduces to the standard Laplace's equation, Eq.(2.95), in the case of a homogeneous medium.

PROBLEM 2.20 Vacuum diode. (a) We apply the one-dimensional Poisson's equation in the x -coordinate, Eq.(2.98), from which the volume charge density in the vacuum ($\varepsilon = \varepsilon_0$) diode in Fig.2.43 amounts to

$$\rho(x) = -\varepsilon_0 \frac{d^2 V(x)}{dx^2} = -\frac{4\varepsilon_0 V_0 x^{-2/3}}{9d^{4/3}} \quad (0 < x < d). \quad (\text{P2.40})$$

(b)-(c) As in Eq.(2.101), the electric field intensity in the diode is given by

$$\mathbf{E}(x) = -\nabla V = -\frac{dV(x)}{dx} \hat{\mathbf{x}} = -\frac{4V_0 x^{1/3}}{3d^{4/3}} \hat{\mathbf{x}} \quad (0 < x < d). \quad (\text{P2.41})$$

Eq.(1.190) then tells us that the surface charge densities on the cathode and anode (Fig.2.43) are

$$\rho_{s1} = \varepsilon_0 \hat{\mathbf{x}} \cdot \mathbf{E}(0^+) = 0 \quad \text{and} \quad \rho_{s2} = \varepsilon_0 (-\hat{\mathbf{x}}) \cdot \mathbf{E}(d^-) = \frac{4\varepsilon_0 V_0}{3d}, \quad (\text{P2.42})$$

respectively.

(d) Performing a similar integration as in Eq.(1.149) and using the second expression in Eqs.(1.30), the total charge of the diode turns out to be

$$Q = \int_v \rho(x) \underbrace{S dx}_{dv} + \rho_{s1} S + \rho_{s2} S = -\frac{4\varepsilon_0 V_0 S}{9d^{4/3}} \int_{x=0}^d x^{-2/3} dx + \frac{4\varepsilon_0 V_0 S}{3d} = 0, \quad (\text{P2.43})$$

where S stands for the (inner) surface area of the cathode or anode in Fig.2.43.

PROBLEM 2.21 Application of Poisson's equation in spherical coordinates. This is similar to the application of Poisson's equation in Cartesian coordinates in Example 2.7.

(a) Because of the spherical symmetry of the problem, the electric potential depends only on the radial spherical coordinate r , so that the formula for the Laplacian in spherical coordinates, Eq.(2.97), retains only the first term. Combining this formula with Poisson's equation, Eq.(2.93), we have

$$\nabla^2 V = \frac{1}{r^2} \frac{d}{dr} \left(r^2 \frac{dV}{dr} \right) = -\frac{\rho(r)}{\varepsilon_0} = -\frac{\rho_0 r}{\varepsilon_0 a} \quad (a < r < b), \quad (\text{P2.44})$$

and the resulting second-order differential equation in r is solved by two integrations, like in Eq.(2.99), as follows:

$$\begin{aligned} r^2 \frac{dV}{dr} &= \int \left(-\frac{\rho_0 r^3}{\varepsilon_0 a} \right) dr = -\frac{\rho_0 r^4}{4\varepsilon_0 a} + C_1 \quad \longrightarrow \quad V(r) = \int \left(-\frac{\rho_0 r^2}{4\varepsilon_0 a} + \frac{C_1}{r^2} \right) dr \\ &= -\frac{\rho_0 r^3}{12\varepsilon_0 a} - \frac{C_1}{r} + C_2. \end{aligned} \quad (\text{P2.45})$$

The integration constants, C_1 and C_2 , are computed from the boundary conditions at the surfaces of metallic electrodes,

$$V(a) = -\frac{\rho_0 a^2}{12\varepsilon_0} - \frac{C_1}{a} + C_2 = V_0 \quad \text{and} \quad V(b) = -\frac{\rho_0 b^3}{12\varepsilon_0 a} - \frac{C_1}{b} + C_2 = 0. \quad (\text{P2.46})$$

Substituting the numerical data (note that $\rho_0 = 3 \mu\text{C}/\text{m}^3$), the two equations (in two unknowns, C_1 and C_2) become

$$-100C_1 + C_2 = 12.82 \quad \text{and} \quad -20C_1 + C_2 = 352.9 \quad (C_1 \text{ in } \text{V} \cdot \text{m}; C_2 \text{ in } \text{V}), \quad (\text{P2.47})$$

and their solution is $C_1 = 4.251 \text{ V} \cdot \text{m}$ and $C_2 = 438 \text{ V}$. Hence, the potential at an arbitrary point between the electrodes, for $a < r < b$, given with respect to the outer electrode, which is at zero potential, comes out to be

$$V(r) = \left(-2.823 \times 10^6 r^3 - \frac{4.251}{r} + 438 \right) \text{V} \quad (r \text{ in m}). \quad (\text{P2.48})$$

(b) In the same way as in Eq.(P1.81), we obtain the electric field vector between the electrodes ($a < r < b$) from the result for V in Eq.(P2.48):

$$\mathbf{E}(r) = -\nabla V = -\frac{dV}{dr} \hat{\mathbf{r}} = \left(8.47 \times 10^6 r^2 - \frac{4.251}{r^2} \right) \hat{\mathbf{r}} \text{ V/m} \quad (r \text{ in m}). \quad (\text{P2.49})$$

PROBLEM 2.22 Application of Laplace's equation in spherical coordinates. Since $\rho = 0$ between the electrodes, we are now solving the one-dimensional Laplace's equation in the radial spherical coordinate r ,

$$\nabla^2 V = \frac{1}{r^2} \frac{d}{dr} \left(r^2 \frac{dV}{dr} \right) = 0 \quad (a < r < b), \quad (\text{P2.50})$$

and the two integrations result in

$$r^2 \frac{dV}{dr} = C_1 \quad \longrightarrow \quad V(r) = \int \frac{C_1}{r^2} dr = -\frac{C_1}{r} + C_2. \quad (\text{P2.51})$$

From the boundary conditions,

$$V(a) = -\frac{C_1}{a} + C_2 = V_0 \quad \text{and} \quad V(b) = -\frac{C_1}{b} + C_2 = 0, \quad (\text{P2.52})$$

and hence $C_1 = -0.125 \text{ V} \cdot \text{m}$ and $C_2 = -2.5 \text{ V}$, with which the solution for the potential in Eq.(P2.51) becomes

$$V(r) = \left(\frac{0.125}{r} - 2.5 \right) \text{V} \quad (r \text{ in m}). \quad (\text{P2.53})$$

(b) The electric field for $a < r < b$ is given by

$$\mathbf{E}(r) = -\frac{dV}{dr} \hat{\mathbf{r}} = \frac{0.125}{r^2} \hat{\mathbf{r}} \text{ V/m} \quad (r \text{ in m}). \quad (\text{P2.54})$$

Section 2.11 Finite-Difference Method for Numerical Solution of Laplace's Equation

PROBLEM 2.23 FD computer program – iterative solution. Computer program for the finite-difference analysis of the coaxial cable of square cross section (Fig.2.13) based on Eq.(2.107) is given in the associated MATLAB exercise.

(a) Simulation results for the distribution of the potential and the electric field intensity in the space between the conductors and for the charge distribution of the conductors of the square coaxial cable, taking the grid spacing to be $d = a/10$ and the tolerance of the potential $\delta_V = 10^{-8} \text{ V}$, are shown in Fig.P2.5.

(b) The computed total charges per unit length of the inner and outer conductors of the cable [Eq.(2.111)], taking $d = a/N$ and $N = 2, 3, 5, 7, 9, 10, 12$, and 25, respectively, are tabulated in Table P2.1.

Table P2.1 Total charges p.u.l. of the inner and outer conductors of the square coaxial cable in Fig.2.13.

N	$Q'_{\text{inner}} [\text{C/m}]$	$Q'_{\text{outer}} [\text{C/m}]$
2	0.8854×10^{-10}	-1.0625×10^{-10}
3	0.9391×10^{-10}	-1.0983×10^{-10}
5	0.9847×10^{-10}	-1.1084×10^{-10}
7	1.0066×10^{-10}	-1.1083×10^{-10}
9	1.0201×10^{-10}	-1.1074×10^{-10}
10	1.0252×10^{-10}	-1.1069×10^{-10}
12	1.0332×10^{-10}	-1.1060×10^{-10}
25	1.0579×10^{-10}	-1.1032×10^{-10}

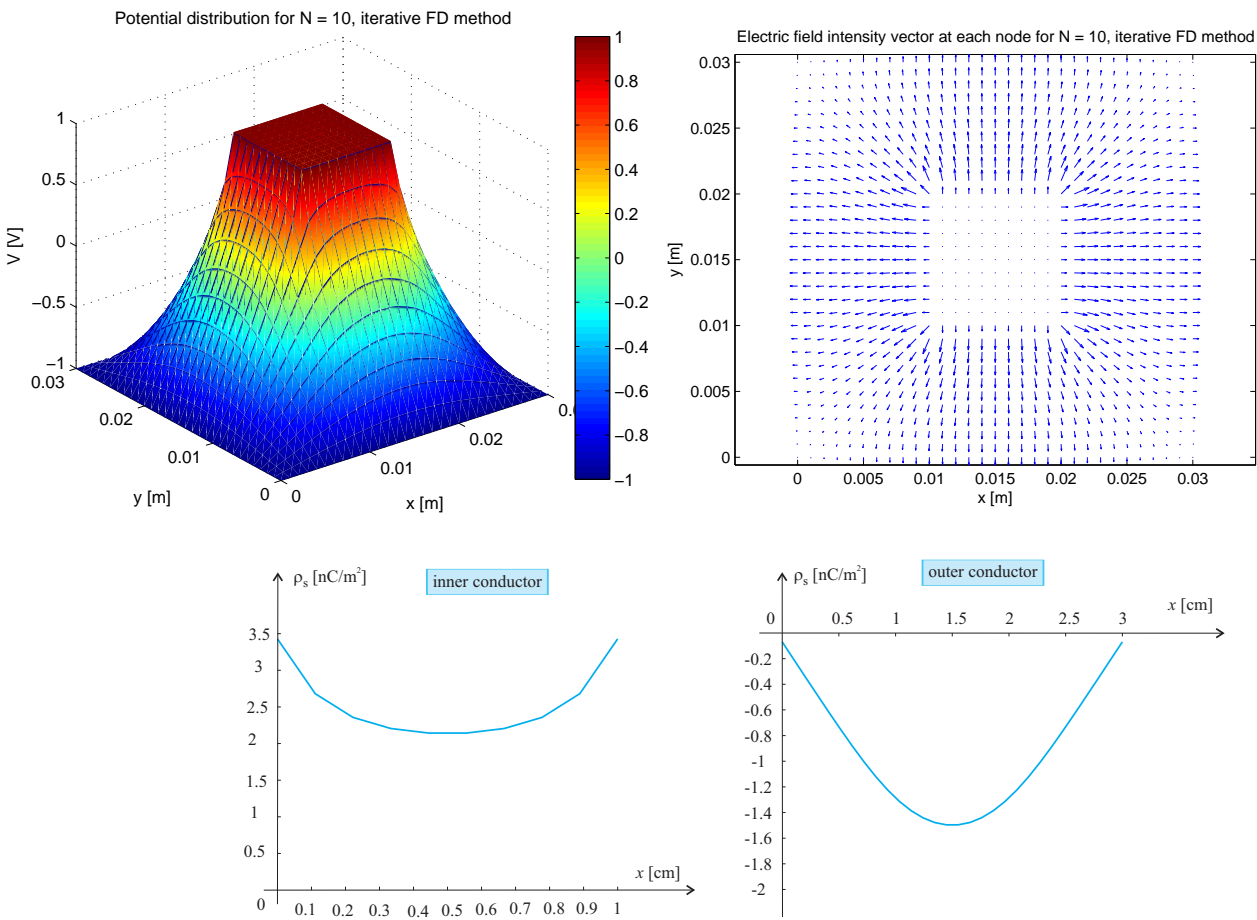

Figure P2.5 Electric potential and field intensity in the space between the conductors, and the surface charge density on the surfaces of conductors, of the coaxial cable of square cross section in Fig.2.13 – results by the iterative finite-difference technique [Eqs.(2.107)-(2.110)] (FD computer program is provided in the associated MATLAB exercise).

PROBLEM 2.24 FD computer program – direct solution. Computer program for the finite-difference analysis of a square coaxial cable by directly solving the system of linear algebraic equations with the potentials at interior grid nodes in Fig.2.13(b) as unknowns is provided in the associated MATLAB exercise.

(a) The computed potential, field, and charge distributions, using the direct FD technique, are shown in Fig.P2.6. An excellent agreement with the results by the iterative FD technique (previous problem) is observed [also in part (b)].

(b) Table P2.2 contains the results, obtained by the direct FD technique, for the

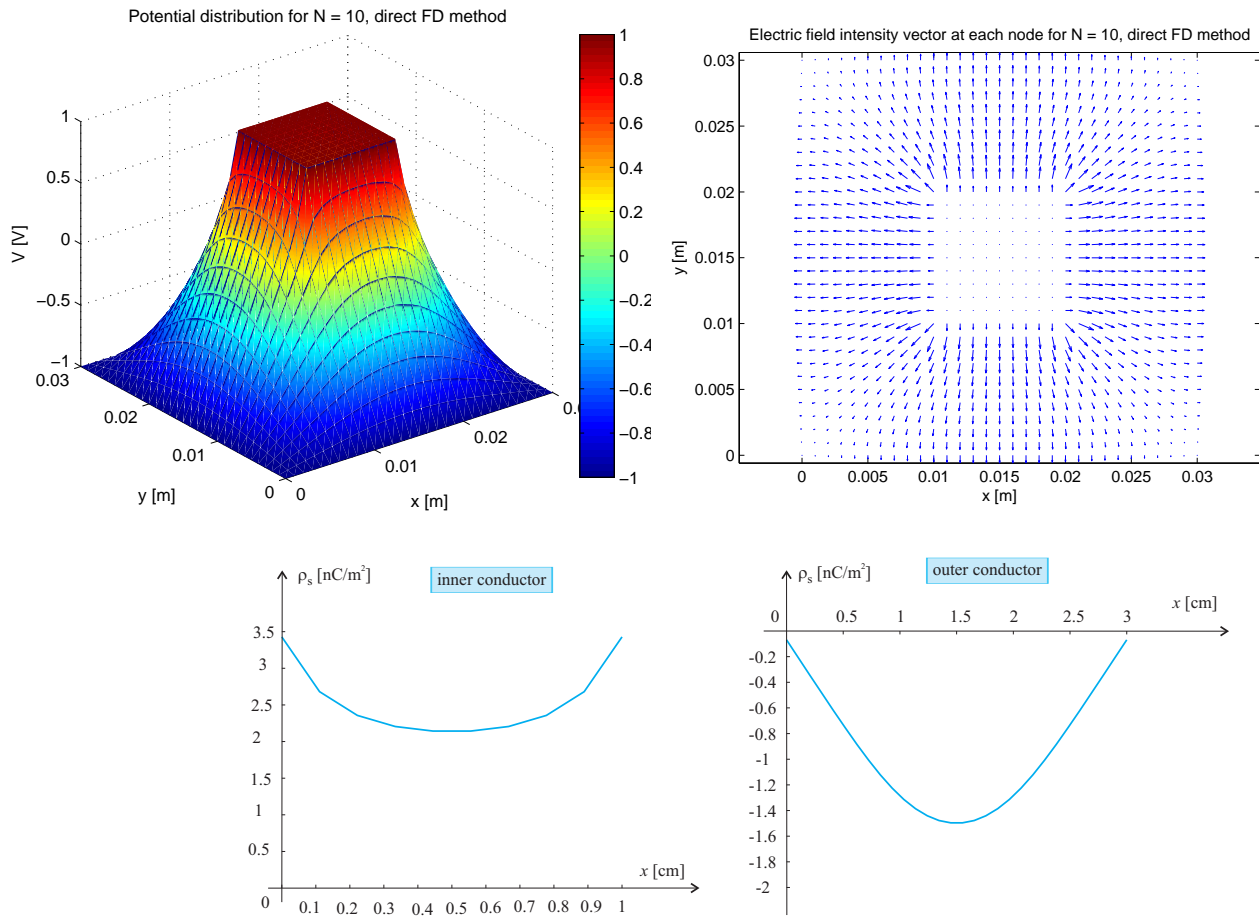

Figure P2.6 Electric potential, field, and charge distributions of the square coaxial cable in Fig.2.13 – results by the direct finite-difference technique (computer program is given in the associated MATLAB exercise).

total charges per unit length of the inner and outer conductors of the cable.

Table P2.2 Total p.u.l. charges of cable conductors obtained by the direct FD technique.

N	$Q'_{\text{inner}} [\text{C/m}]$	$Q'_{\text{outer}} [\text{C/m}]$
2	0.8854×10^{-10}	-1.0625×10^{-10}
3	0.9391×10^{-10}	-1.0983×10^{-10}
5	0.9847×10^{-10}	-1.1084×10^{-10}
7	1.0066×10^{-10}	-1.1083×10^{-10}
9	1.0201×10^{-10}	-1.1074×10^{-10}
10	1.0252×10^{-10}	-1.1069×10^{-10}
12	1.0332×10^{-10}	-1.1060×10^{-10}
25	1.0580×10^{-10}	-1.1032×10^{-10}

Section 2.13 Analysis of Capacitors with Homogeneous Dielectrics

PROBLEM 2.25 Capacitance of the earth. Using Eq.(2.121), the capacitance of the earth turns out to be

$$C_{\text{earth}} = 4\pi\epsilon_0 R = 709.6 \mu\text{F} \quad (R = 6378 \text{ km}). \quad (\text{P2.55})$$

PROBLEM 2.26 Capacitance of a person. Taking the diameters of the inscribed and overscribed spheres to be $2R_{\text{min}} = 30 \text{ cm}$ and $2R_{\text{max}} = 170 \text{ cm}$, respectively (note that these adopted dimensions are completely arbitrary, and are just meant to be illustrative of an estimated value of the capacitance), that is, $R_{\text{min}} = 15 \text{ cm}$ and $R_{\text{max}} = 85 \text{ cm}$, we have $4\pi\epsilon_0 R_{\text{min}} = 16.7 \text{ pF}$ and $4\pi\epsilon_0 R_{\text{max}} = 94.6 \text{ pF}$. Therefore, the capacitance of an average human body can be estimated to be within the range $16.7 \text{ pF} < C < 94.6 \text{ pF}$.

PROBLEM 2.27 Capacitance of a metallic cube, computed by the MoM. The capacitance of the metallic cube numerically analyzed by the method of moments in Problem 1.85 amounts to $C = Q/V_0 = 73.27 \text{ pF}$. The capacitances of the metallic sphere [Eq.(2.121)] inscribed in the cube (sphere radius $r_a = a/2$), the sphere overscribed about the cube ($r_b = a\sqrt{3}/2$), the one with $r_c = (r_a + r_b)/2$, the sphere having the same surface as the cube [$r_d = a\sqrt{3}/(2\pi)$], and that with the same volume as the cube $\{r_e = a[3/(4\pi)]^{1/3}\}$ come out to be $C_a = 55.63 \text{ pF}$, $C_b = 96.36 \text{ pF}$, $C_c = 76 \text{ pF}$, $C_d = 76.88 \text{ pF}$, and $C_e = 69.02 \text{ pF}$, respectively. We see that the capacitance of the sphere whose radius equals the arithmetic mean of the radii of spheres inscribed in and overscribed about the cube ($C_c = 76 \text{ pF}$) is quite close in value to the capacitance of the cube.

PROBLEM 2.28 RG-55/U coaxial cable. Using Eq.(2.123), the capacitance per unit length of the RG-55/U coaxial cable amounts to $C' = 2\pi\epsilon_r\epsilon_0/\ln(b/a) = 70 \text{ pF/m}$.

PROBLEM 2.29 Capacitance p.u.l. of a square coaxial cable, FD analysis. The capacitance per unit length of the coaxial cable of square cross section in Fig.2.13 numerically analyzed by the finite-difference technique presented in Section 2.11 is obtained to be $C'_{\text{iterative}} = 51.26006 \text{ pF/m}$ by the iterative FD technique (Problem 2.23) and $C'_{\text{direct}} = 51.26008 \text{ pF/m}$ by the direct FD technique (Problem 2.24), so practically the same result, with the tolerance of the potential of $\delta_V = 10^{-8} \text{ V}$ in the iterative solution and the grid spacing of $d = a/10$ in both solutions. As a reference, the per-unit-length capacitance of a (standard) coaxial cable

(of circular cross section) having the same ratio of conductor radii ($b/a = 3$) and dielectric (air) as the square cable is $C'_{\text{standard coax}} = 50.61 \text{ pF/m}$ [from Eq.(2.123)].

PROBLEM 2.30 Parallel-plate capacitor model of a thundercloud.

Based on Eqs.(2.127) and (2.126), the capacitance of the parallel-plate capacitor approximating a thundercloud, the voltage between the top and bottom of the cloud, and the electric field intensity in the cloud come out to be $C = \epsilon_0 S/d = 132.8 \text{ nF}$, $V = Q/C = 2.26 \text{ GV}$, and $E = V/d = 2.26 \text{ MV/m}$, respectively.

PROBLEM 2.31 MoM numerical analysis of a parallel-plate capacitor.

Computer program based on the method of moments for the analysis of the parallel-plate capacitor in Fig.2.19 is given in the associated MATLAB exercise. Using the MoM program, the capacitance (C) of this capacitor for d/a ratios of 0.1, 0.5, 1, 2, and 10 is found to be 117 pF, 38.3 pF, 28.7 pF, 24 pF, and 20.6 pF, respectively. The corresponding C values obtained from Eq.(2.127), which neglects the fringing effects, turn out to be 88.5 pF, 17.7 pF, 8.85 pF, 4.43 pF, and 0.885 pF.

PROBLEM 2.32 Nonsymmetrical thin two-wire line.

The only difference with respect to the analysis of a symmetrical thin two-wire transmission line in air, Fig.2.22, is the upper integration limit in computing the voltage between the line conductors. Incorporating this change in Eqs.(2.140) and (2.141), we obtain the following expression for the capacitance per unit length of a nonsymmetrical thin two-wire line:

$$\begin{aligned} V &= \int_{x=a}^{d-b} E \, dx = \frac{Q'}{2\pi\epsilon_0} \left[\int_a^{d-b} \frac{dx}{x} - \int_a^{d-b} \frac{d(d-x)}{d-x} \right] \\ &= \frac{Q'}{2\pi\epsilon_0} \left[\ln x \Big|_a^{d-b} - \ln(d-x) \Big|_a^{d-b} \right] = \frac{Q'}{2\pi\epsilon_0} \left(\ln \frac{d-b}{a} - \ln \frac{b}{d-a} \right) \\ &= \frac{Q'}{2\pi\epsilon_0} \ln \frac{(d-a)(d-b)}{ab} \approx \frac{Q'}{2\pi\epsilon_0} \ln \frac{d^2}{ab} \quad \longrightarrow \quad C' = \frac{Q'}{V} \approx \frac{\pi\epsilon_0}{\ln(d/\sqrt{ab})} \quad (\text{P2.56}) \end{aligned}$$

(since $d-a \approx d$ and $d-b \approx d$).

Similarly, we can pursue an alternative way of obtaining C' based on Eq.(1.197), as in Eqs.(2.142) and (2.143), which now become

$$V_{M_1} = \frac{Q'}{2\pi\epsilon_0} \ln \frac{d-b}{a} + \frac{-Q'}{2\pi\epsilon_0} \ln \frac{b}{d-a} \quad \longrightarrow \quad C' = \frac{Q'}{V_{M_1}} \approx \frac{\pi\epsilon_0}{\ln(d/\sqrt{ab})}. \quad (\text{P2.57})$$

Of course, for $a = b$, the result for C' in Eq.(P2.56) or (P2.57) reduces to that in Eq.(2.141).

PROBLEM 2.33 Thick symmetrical two-wire line.

The capacitance per unit length of a (thick or thin) symmetrical two-wire line with the wire distance to

radius ratio d/a in air computed using the two expressions,

$$C'_1 = \frac{\pi\epsilon_0}{\ln\{d/(2a) + \sqrt{[d/(2a)]^2 - 1}\}} \quad \text{and} \quad C'_2 = \frac{\pi\epsilon_0}{\ln(d/a)}, \quad (\text{P2.58})$$

for different values of d/a are given in Table P2.3. We see that the results obtained with the thin-wire approximation of the line (C'_2) are quite accurate for $d/a \geq 10$, and are acceptable even for $d/a \geq 5$.

Table P2.3 Capacitance p.u.l. of a two-wire line computed by expressions in Eqs.(P2.58).

d/a	C'_1 (pF/m)	C'_2 (pF/m)	Error (%)
3	28.9	25.32	14.15
5	17.754	17.283	2.72
10	12.134	12.08	0.443
20	9.2931	9.2853	0.084
100	6.04036	6.04023	0.0022

PROBLEM 2.34 Two small metallic spheres in air. The capacitor consisting of two small metallic spheres in air can be analyzed as the thin two-wire line in Fig.2.22, by just changing the field dependence $Q'/(2\pi\epsilon_0 r)$ to $Q/(4\pi\epsilon_0 r^2)$. With this, Eq.(2.139) becomes

$$E = E_1 + E_2 = \frac{Q}{4\pi\epsilon_0} \left[\frac{1}{x^2} + \frac{1}{(d-x)^2} \right], \quad (\text{P2.59})$$

and the voltage of the capacitor is, in place of Eq.(2.140), found as

$$\begin{aligned} V &= \int_{x=a}^{d-a} E \, dx = \frac{Q}{4\pi\epsilon_0} \left[\int_a^{d-a} \frac{dx}{x^2} - \int_a^{d-a} \frac{d(d-x)}{(d-x)^2} \right] \\ &= \frac{Q}{4\pi\epsilon_0} \left[\frac{1}{a} - \frac{1}{d-a} - \left(\frac{1}{d-a} - \frac{1}{a} \right) \right] = \frac{Q}{2\pi\epsilon_0} \left(\frac{1}{a} - \frac{1}{d-a} \right) \approx \frac{Q}{2\pi\epsilon_0 a} \quad (d \gg a). \end{aligned} \quad (\text{P2.60})$$

Its capacitance is

$$C = \frac{Q}{V} = 2\pi\epsilon_0 a. \quad (\text{P2.61})$$

Note that, since $d \gg a$, the voltage between the two spheres can alternatively be obtained using the expression for the potential of an isolated metallic sphere, Eq.2.120, twice. Namely, V can be computed as the voltage from the first sphere (with charge Q) to the reference point for potential (at infinity) plus the voltage from the reference point to the second sphere (the one with charge $-Q$), where the two voltages equal the potential (with respect to infinity) of the first sphere and the negative of the potential of the second sphere, respectively, so that

$$V = V_{\text{sphere with } Q} + (-V_{\text{sphere with } -Q}) = \frac{Q}{4\pi\epsilon_0 a} + \left(-\frac{-Q}{4\pi\epsilon_0 a} \right) = \frac{Q}{2\pi\epsilon_0 a}. \quad (\text{P2.62})$$

PROBLEM 2.35 **Four parallel wires in air.** Let the first conductor of the transmission line (the upper pair of wires) in Fig.2.44 be charged by Q' and the second conductor (the lower pair of wires) by $-Q'$ per unit of their length. Because of symmetry, both charges, Q' and $-Q'$, are distributed equally between the connected wires, as shown in Fig.P2.7. Assuming that the second conductor of the line (consisting of wires 3 and 4) is at a zero potential, the potential of the first conductor, namely, the potential at the point M_1 on the surface of wire 1 (Fig.P2.7), with respect to the reference point M_2 taken on the surface of wire 3 ($V_{M_2} = 0$) equals the sum of the corresponding potentials (at M_1 , with respect to M_2) due to charged wires 1-4. Each of these potentials is computed using Eq.(1.197), as follows [also see Eq.(2.144)]:

$$V_{M_1} = \frac{Q'/2}{2\pi\epsilon_0} \ln \frac{d}{a} + \frac{Q'/2}{2\pi\epsilon_0} \ln \frac{d\sqrt{2}}{d} + \frac{-Q'/2}{2\pi\epsilon_0} \ln \frac{a}{d} + \frac{-Q'/2}{2\pi\epsilon_0} \ln \frac{d}{d\sqrt{2}} = \frac{Q'}{2\pi\epsilon_0} \ln \frac{d\sqrt{2}}{a}, \quad (\text{P2.63})$$

so that the capacitance per unit length of the line amounts to

$$C' = \frac{Q'}{V_{M_1}} = \frac{2\pi\epsilon_0}{\ln(d\sqrt{2}/a)} = 9.86 \text{ pF/m}. \quad (\text{P2.64})$$

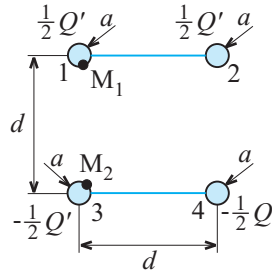

Figure P2.7 Evaluation of the capacitance p.u.l. of the transmission line in Fig.2.44 (cross section of the structure).

PROBLEM 2.36 **Two wires at the same potential and a foil.** (a) We assume that the first conductor (consisting of the two connected wires) of the transmission line in Fig.2.45 (whose other conductor is the metallic foil) is charged by Q' , i.e., that each of the wires is charged by $Q'/2$, and replace the foil by negative images of the wires, as shown in Fig.P2.8. The voltage between wire 1 (or wire 2) and the foil in the original system (Fig.2.45) equals a half of the voltage between wires 1 and 3 in the equivalent system, so that, as in Eq.(2.146), the capacitance per unit length of the original transmission line turns out to be twice that of the equivalent line with wires 1 and 2 as one conductor and wires 3 and 4 as the other conductor, in Fig.P2.8. This latter capacitance (C'_e) is evaluated using Eq.(1.197), as in the previous problem,

$$V_{M_1} = \frac{Q'/2}{2\pi\epsilon_0} \ln \frac{2h}{a} + \frac{Q'/2}{2\pi\epsilon_0} \ln \frac{D}{d} + \frac{-Q'/2}{2\pi\epsilon_0} \ln \frac{a}{2h} + \frac{-Q'/2}{2\pi\epsilon_0} \ln \frac{d}{D} = \frac{Q'}{2\pi\epsilon_0} \ln \frac{2hD}{ad}$$

$$\rightarrow C'_e = \frac{Q'}{V_{M_1}} = \frac{2\pi\epsilon_0}{\ln[2hD/(ad)]} = 13.25 \text{ pF/m}, \quad D = \sqrt{d^2 + (2h)^2}, \quad (\text{P2.65})$$

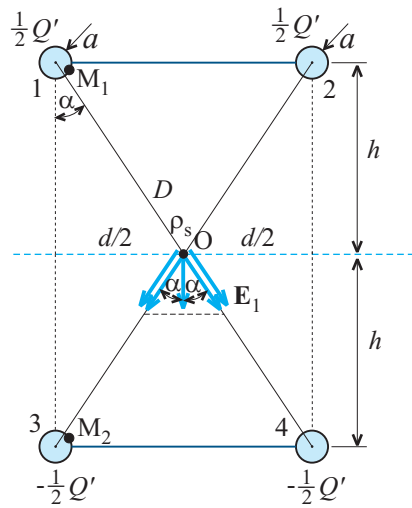

Figure P2.8 Equivalent (in the upper half-space) transmission line to that in Fig.2.45, by virtue of image theory.

and thus the capacitance p.u.l. of the line in Fig.2.45 (between the short-circuited two-wire line and the metallic foil) is $C' = 2C'_e = 26.5 \text{ pF/m}$.

(b) The induced surface charge density (ρ_s) at the point O on the foil (in Fig.2.45) is obtained in a similar way to that carried out in Problem 1.88 or in Eqs.(1.220) and (1.221). With reference to Fig.P2.8, we have

$$\rho_s = -\epsilon_0 E_{\text{tot}} = -\epsilon_0 (4E_1 \cos \alpha), \quad E_1 = \frac{Q'/2}{2\pi\epsilon_0(D/2)}, \quad Q' = C'V, \quad \cos \alpha = \frac{2h}{D} \tag{P2.66}$$

($V = 20 \text{ V}$), and hence $\rho_s = -5.4 \text{ nC/m}^2$.

PROBLEM 2.37 **Capacitance per unit length of a wire-corner line.** To find the capacitance per unit length of the transmission line in Fig.1.57, whose one conductor is the thin metallic wire and the other conductor is the 90° corner metallic screen, we use the expression for the voltage V between the wire and the screen obtained in Problem 1.89, and write

$$C' = \frac{Q'}{V} = \frac{2\pi\epsilon_0}{\ln(h\sqrt{2}/a)} = 13.06 \text{ pF/m} . \tag{P2.67}$$

PROBLEM 2.38 **Equivalent circuit with two spherical capacitors.** (a)-(b) The system in Fig.1.41 can be replaced by two air-filled spherical capacitors, one with radii of electrodes a and b , as in Fig.2.16, and the other with radii c and $d \rightarrow \infty$ (in place of a and b), which gives rise to the equivalent circuit in Fig.2.46. The capacitances of the capacitors in the schematic diagram are thus, from Eq.(2.119),

$$C_{ab} = \frac{4\pi\epsilon_0 ab}{b - a} \quad \text{and} \quad C_{cd} = 4\pi\epsilon_0 c, \tag{P2.68}$$

where C_{cd} can also be obtained from Eq.(2.121), as the capacitance of an isolated metallic sphere of radius c in air.

(c) The charge of the first (left) electrode of the first capacitor (of capacitance C_{ab}) in Fig.2.46 equals the charge of the metallic sphere in Fig.1.41, so $Q_a = Q$. The charge of the second electrode of this capacitor is opposite, hence $Q_b = -Q_a = -Q$. Since the metallic shell in Fig.1.41 is uncharged, and it is represented by the second electrode of the first capacitor and first electrode of the second capacitor (of capacitance C_{cd}) in the equivalent circuit, we have $Q_b + Q_c = 0$ and $Q_c = -Q_b = Q$ in Fig.2.46, and then $Q_d = -Q_c = -Q$ for the second capacitor.

From Fig.2.46, the potential at the point O in Fig.1.41, that is, the potential of the metallic sphere, can be obtained, using Eqs.(2.113) and (P2.68), as

$$V = V_{ab} + V_{cd} = \frac{Q_a}{C_{ab}} + \frac{Q_c}{C_{cd}} = \frac{Q(bc - ac + ab)}{4\pi\epsilon_0 abc}, \quad (\text{P2.69})$$

which, of course, is the same result as in Eq.(1.202).

PROBLEM 2.39 Equivalent circuit with three spherical capacitors. (a)

With a similar reasoning as in the previous problem, we replace the system of three metallic shells from Problem 1.77 by an equivalent circuit shown in Fig.P2.9, where the capacitances of the three spherical capacitors amount to

$$C_{ab} = \frac{4\pi\epsilon_0 ab}{b-a} = 8.34 \text{ pF}, \quad C_{cd} = \frac{4\pi\epsilon_0 cd}{d-c} = 20 \text{ pF}, \quad C_{ef} = 4\pi\epsilon_0 e = 11.13 \text{ pF}. \quad (\text{P2.70})$$

For the charges of individual electrodes of capacitors, we now have

$$\begin{aligned} Q_a = Q = 10 \text{ nC}, \quad Q_b = -Q_a = -Q, \quad Q_b + Q_c = Q_m \quad (\text{unknown}), \\ Q_d = -Q_c, \quad Q_d + Q_e = 0 \quad (\text{outer shell uncharged}). \end{aligned} \quad (\text{P2.71})$$

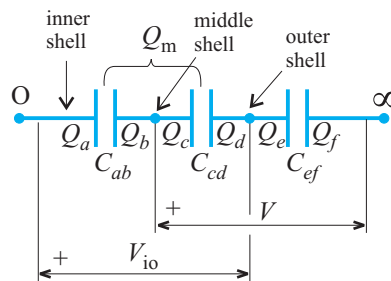

Figure P2.9 Equivalent circuit (with three spherical capacitors) for the system of three spherical metallic shells from Problem 1.77.

From the schematic diagram in Fig.P2.9 and Eqs.(P2.71), the given potential of the middle shell with respect to the reference point at infinity can be expressed as

$$V = V_{cd} + V_{ef} = \frac{Q_c}{C_{cd}} + \frac{Q_e}{C_{ef}} = \frac{-Q_d}{C_{cd}} + \frac{-Q_d}{C_{ef}} = -Q_d \frac{C_{cd} + C_{ef}}{C_{cd}C_{ef}} \quad (V = 1 \text{ kV}), \quad (\text{P2.72})$$

and hence, using Eqs.(P2.70) as well, the charge of the middle shell (Q_m) turns out to be

$$Q_d = -\frac{C_{cd}C_{ef}V}{C_{cd} + C_{ef}} = -7.15 \text{ nC} \quad \longrightarrow \quad Q_m = Q_b + Q_c = -Q - Q_d = -2.85 \text{ nC} . \quad (\text{P2.73})$$

The voltage between the inner and outer shells equals

$$V_{io} = V_{ab} + V_{cd} = \frac{Q_a}{C_{ab}} + \frac{Q_c}{C_{cd}} = \frac{Q}{C_{ab}} + \frac{-Q_d}{C_{cd}} = 1.55 \text{ kV} , \quad (\text{P2.74})$$

the same as in Eq.(P1.154).

(b) For changed conditions in the circuit in Fig.P2.9 (and a slightly different notation), set in Problem 1.78, the charges of capacitor electrodes are given by

$$Q_a = Q_1 = 2 \text{ nC} , \quad Q_b = -Q_a = -Q_1 , \quad Q_b + Q_c = Q_2 = Q_m \quad (\text{unknown}) ,$$

$$Q_d = -Q_c , \quad Q_d + Q_e = Q_3 = -2 \text{ nC} \quad (\text{outer shell is now charged}) , \quad (\text{P2.75})$$

from which the charges of the second and third capacitors are $Q_c = Q_1 + Q_2$ and $Q_e = Q_1 + Q_2 + Q_3$, respectively. Since the voltage between the inner and outer shells is zero, we obtain the charge of the middle shell (Q_2) as follows:

$$0 = V_{ab} + V_{cd} = \frac{Q_a}{C_{ab}} + \frac{Q_c}{C_{cd}} = \frac{Q_1}{C_{ab}} + \frac{Q_1 + Q_2}{C_{cd}} \quad \longrightarrow \quad Q_2 = -6.8 \text{ nC} . \quad (\text{P2.76})$$

Finally, the potential of the inner and outer shells ($V_1 = V_3$) and that of the middle shell (V_2), with respect to the reference point at infinity, are

$$V_1 = V_3 = V_{ef} = \frac{Q_e}{C_{ef}} = \frac{Q_1 + Q_2 + Q_3}{C_{ef}} = -611 \text{ V} ,$$

$$V_2 = V_{cd} + V_3 = \frac{Q_c}{C_{cd}} + V_3 = \frac{(Q_1 + Q_2)}{C_{cd}} + V_3 = -851 \text{ V} , \quad (\text{P2.77})$$

which are the same results as in Problem 1.78.

PROBLEM 2.40 Equivalent circuit with parallel-plate capacitors. The capacitors in the equivalent circuit in Fig.2.47 are parallel-plate capacitors, whose capacitances are found from Fig.1.42 neglecting the fringing effects and using Eq.(2.127):

$$C_1 = C_2 = C_3 = \epsilon_0 \frac{S}{d} = 442.7 \text{ pF} . \quad (\text{P2.78})$$

We express the given potential V of the second electrode with respect to the ground as the voltage, in Fig.2.47, between that electrode and the first one (which is grounded) and as the voltage to the fourth electrode (also grounded), respectively. We also express the given charge Q of the third electrode as the sum of charges of the corresponding capacitor plates (in Fig.2.47). What we obtain are the following three equations:

$$V = V_2 = V_{21} = -V_{12} = -\frac{Q_1}{C_1} , \quad V = V_{23} + V_{34} = \frac{Q_2}{C_2} + \frac{Q_3}{C_3} , \quad -Q_2 + Q_3 = Q , \quad (\text{P2.79})$$

whose solution is $Q_1 = -885.4$ nC, $Q_2 = -557.3$ nC, and $Q_3 = 1.443$ μ C. By means of Eqs.(2.126) and (2.113), the electric field intensities in capacitors in Fig.2.47, i.e., between the electrodes in Fig.1.42(b), amount to

$$E_1 = \frac{V_{12}}{d} = \frac{Q_1}{C_1 d} = -100 \text{ kV/m}, \quad E_2 = \frac{V_{23}}{d} = \frac{Q_2}{C_2 d} = -63 \text{ kV/m},$$

$$E_3 = \frac{V_{34}}{d} = \frac{Q_3}{C_3 d} = 163 \text{ kV/m}. \quad (\text{P2.80})$$

Of course, $E_4 = 0$ in Fig.1.42(b), as the field in the (fourth) capacitor with short-circuited plates, which is not shown in Fig.2.47.

PROBLEM 2.41 **Equivalent circuit with cylindrical capacitors.** Fig.P2.10 shows an equivalent circuit with three cylindrical capacitors, whose capacitances per unit length of the system in Fig.1.55 are computed using the expression for C' of a coaxial cable, Eq.(2.123),

$$C'_{12} = \frac{2\pi\epsilon_0}{\ln[3d/(2d)]} = 137.2 \text{ pF/m}, \quad C'_{23} = \frac{2\pi\epsilon_0}{\ln[5d/(4d)]} = 249.3 \text{ pF/m},$$

$$C'_{34} = \frac{2\pi\epsilon_0}{\ln[7d/(6d)]} = 360.9 \text{ pF/m}. \quad (\text{P2.81})$$

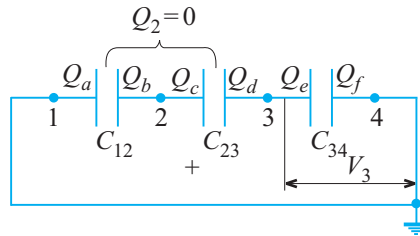

Figure P2.10 Equivalent circuit (with three cylindrical capacitors) for the system of four cylindrical conductors (shells) in Fig.1.55.

From the given potential of the third conductor (cylindrical shell) in Fig.1.55 with respect to the ground, expressed, in the circuit in Fig.P2.10, via the voltage between that conductor and the fourth one, we get

$$V_3 = \frac{Q'_e}{C'_{34}} \quad (V_3 = 1 \text{ kV}) \quad \longrightarrow \quad Q'_e = C'_{34} V_3 = 360.9 \text{ nC/m}. \quad (\text{P2.82})$$

Since the second conductor is uncharged, we see (in Fig.P2.10) that

$$Q'_b + Q'_c = Q'_2 = 0 \quad \longrightarrow \quad Q'_c = -Q'_b = Q'_a. \quad (\text{P2.83})$$

Expressing then V_3 via the voltage on the other side, to the first conductor, gives

$$V_3 = -\frac{Q'_a}{C'_{12}} - \frac{Q'_c}{C'_{23}} = -Q'_a \frac{C'_{12} + C'_{23}}{C'_{12} C'_{23}} \quad \longrightarrow \quad Q'_a = -\frac{C'_{12} C'_{23} V_3}{C'_{12} + C'_{23}} = 88.5 \text{ nC/m}. \quad (\text{P2.84})$$

Hence, the total charges p.u.l. of the first and third conductors (in Fig.1.55) come out [from Fig.P2.10 and Eqs.(P2.82)-(P2.84)] to be

$$Q'_1 = Q'_a = -88.5 \text{ nC/m}, \quad Q'_3 = Q'_d + Q'_e = -Q'_c + Q'_e = -Q'_a + Q'_e = 450 \text{ nC/m}, \quad (\text{P2.85})$$

and the results are the same as those obtained in Problem 1.79.

Section 2.14 Analysis of Capacitors with Inhomogeneous Dielectrics

PROBLEM 2.42 Spherical capacitor with a solid and liquid dielectric.

In the first (old) electrostatic state, the charge of the capacitor is, from Eq.(2.164),

$$Q = 4\pi\epsilon_0 \left(\frac{b-a}{\epsilon_{r1}ab} + \frac{c-b}{\epsilon_{r2}bc} \right)^{-1} V = 1.152 \text{ nC} \quad (V = V_{\text{source}} = 100 \text{ V}). \quad (\text{P2.86})$$

Upon the voltage source is disconnected, and the capacitor is left to itself, this charge remains the same in the new electrostatic state, in which the capacitance of the capacitor is changed (oil is drained from the capacitor, so $\epsilon_{r2} = 1$), and the voltage across open-circuited terminals of the capacitor turns out to be:

$$V_{\text{new}} = \frac{Q}{4\pi\epsilon_0} \left(\frac{b-a}{\epsilon_{r1}ab} + \frac{c-b}{bc} \right) = 136.5 \text{ V}. \quad (\text{P2.87})$$

PROBLEM 2.43 Oil drain without disconnecting the source.

The capacitor charge in the old electrostatic state is $Q = 1.152 \text{ nC}$ (previous problem), and that in the new state (with $\epsilon_{r2} = 1$) amounts to

$$Q_{\text{new}} = 4\pi\epsilon_0 \left(\frac{b-a}{\epsilon_{r1}ab} + \frac{c-b}{bc} \right)^{-1} V_{\text{source}} = 843.3 \text{ pC}. \quad (\text{P2.88})$$

The difference equals the charge flow through the source circuit (in the direction from the positive end of the source toward the positive electrode of the capacitor, that with Q):

$$Q_{\text{flow}} = \Delta Q = Q_{\text{new}} - Q = -308.3 \text{ pC}. \quad (\text{P2.89})$$

PROBLEM 2.44 Metallic sphere with dielectric coating. (a)

This is a D -system, and the electric flux density vector, \mathbf{D} , in both the dielectric coating and air is given by Eqs.(2.161) and (2.162), where Q is the charge of the metallic sphere. The electric field intensity vector is $\mathbf{E}_1 = \mathbf{D}/(\epsilon_r\epsilon_0)$ in the coating and $\mathbf{E}_2 = \mathbf{D}/\epsilon_0$ in air. From this field, we can express, by integration, the potential of the sphere (with respect to the reference point at infinity), V , in terms of Q , and find its capacitance (C) employing Eq.(2.116). Alternatively, we can consider the dielectrically coated

metallic sphere in Fig.2.48 as a special case of the spherical capacitor with two dielectric layers in Fig.2.27, and specialize Eq.(2.164) specifying $\epsilon_{r1} = \epsilon_r$, $\epsilon_{r2} = 1$, and $c \rightarrow \infty$, to obtain

$$C = 4\pi\epsilon_0 \left(\frac{b-a}{\epsilon_r ab} + \frac{1}{b} \right)^{-1} = \frac{4\pi\epsilon_r\epsilon_0 ab}{b-a + \epsilon_r a} = 2.224 \text{ pF}. \quad (\text{P2.90})$$

(b) Using Eq.(2.58) or (1.191), the density of free surface charge on the metallic sphere in Fig.2.48 amounts to

$$\rho_s = D(a^+) = \frac{Q}{4\pi a^2} = \frac{CV}{4\pi a^2} = 1.77 \text{ } \mu\text{C}/\text{m}^2. \quad (\text{P2.91})$$

(c) Eq.(2.60) tells us that there is no bound volume charge in a homogeneous linear medium with no free volume charge; so, in both the dielectric coating and air in Fig.2.48, $\rho_p = 0$.

(d) By means of Eqs.(2.61) and (P2.91), the bound surface charge density on the surface of the dielectric coating next to the metallic sphere equals

$$\rho_{psa} = -\frac{\epsilon_r - 1}{\epsilon_r} \rho_s = -1.327 \text{ } \mu\text{C}/\text{m}^2, \quad (\text{P2.92})$$

while, from Eqs.(2.23), (2.59), and (2.47), the bound surface charge density on the other surface of the coating is

$$\rho_{psb} = P(b^-) = \frac{\epsilon_r - 1}{\epsilon_r} D(b^-) = \frac{\epsilon_r - 1}{\epsilon_r} \frac{CV}{4\pi b^2} = 147.6 \text{ nC}/\text{m}^2. \quad (\text{P2.93})$$

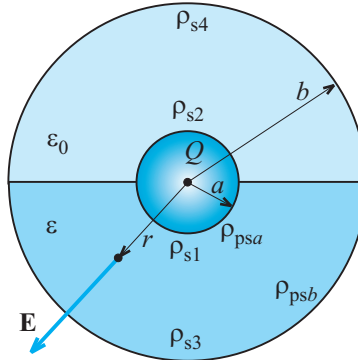

Figure P2.11 Evaluation of the free and bound surface charges in the spherical capacitor half filled with a liquid dielectric in Fig.2.29.

PROBLEM 2.45 Charge densities in a half-filled spherical capacitor.

(a) With the electric field intensity $E(r)$ in the capacitor given in Eq.(2.175) and notation in Fig.P2.11, Eq.(2.58) results in the following free surface charge densities on metallic surfaces of the capacitor:

$$\rho_{s1} = \epsilon_r\epsilon_0 E(a^+) = \frac{\epsilon_r Q}{2\pi(\epsilon_r + 1)a^2} = 2.98 \text{ } \mu\text{C}/\text{m}^2, \quad \rho_{s2} = \epsilon_0 E(a^+) = \frac{Q}{2\pi(\epsilon_r + 1)a^2}$$

$$\begin{aligned}
 &= 995 \text{ nC/m}^2, \quad \rho_{s3} = -\varepsilon_r \varepsilon_0 E(b^-) = -\frac{\varepsilon_r Q}{2\pi(\varepsilon_r + 1)b^2} = -119 \text{ nC/m}^2, \\
 \rho_{s4} &= -\varepsilon_0 E(b^-) = -\frac{Q}{2\pi(\varepsilon_r + 1)b^2} = -39.8 \text{ nC/m}^2. \quad (\text{P2.94})
 \end{aligned}$$

(b) From Eq.(2.61) and (P2.94), bound surface charge densities on dielectric surfaces next to capacitor electrodes in Fig.P2.11 are

$$\rho_{psa} = -\frac{\varepsilon_r - 1}{\varepsilon_r} \rho_{s1} = -1.99 \mu\text{C/m}^2, \quad \rho_{psb} = -\frac{\varepsilon_r - 1}{\varepsilon_r} \rho_{s3} = 79.6 \text{ nC/m}^2, \quad (\text{P2.95})$$

while Eq.(2.23) tells us that there is no bound charge on the surfaces dielectric-air in the capacitor, as vectors \mathbf{E} and \mathbf{P} are tangential on these surfaces.

PROBLEM 2.46 Empty and half-filled spherical capacitor. Using Eq.(2.119), the charge of the empty (air-filled) spherical capacitor in the first electrostatic state equals

$$Q = CV = \frac{4\pi\varepsilon_0 abV}{b-a} \quad (V = V_{\text{source}} = 15 \text{ kV}). \quad (\text{P2.96})$$

Eq.(2.176) then gives the following for the voltage across the open-circuited terminals of the capacitor, half filled with a liquid dielectric, in the new state (Q is the same):

$$V_{\text{new}} = \frac{Q}{C_{\text{new}}} = \frac{(b-a)Q}{2\pi(\varepsilon_r + 1)\varepsilon_0 ab} = \frac{2V}{\varepsilon_r + 1} = 8.571 \text{ kV}. \quad (\text{P2.97})$$

PROBLEM 2.47 Metallic sphere half embedded in a dielectric. (a) This is an E -system, and the electric field intensity vector (\mathbf{E}) is entirely radial. Moreover, it can be evaluated in the same way as in Fig.2.29 and Eq.(2.174), and is given in Eq.(2.175). By integrating $E(r)$ from the metallic sphere surface to the reference point at infinity, we can obtain the potential of the sphere and its capacitance. Alternatively, we can use Eq.(2.176) with $b \rightarrow \infty$. In either way, the capacitance of the metallic sphere in Fig.2.49 comes out to be

$$C = 2\pi(\varepsilon_r + 1)\varepsilon_0 a. \quad (\text{P2.98})$$

(b) The two terms in the application of the generalized Gauss' law in Eq.(2.174) actually show how the charge Q of the metallic sphere in Fig.2.49 is distributed between its two halves; the ratio of the charge on the lower half, Q_1 , to the charge of the upper half, Q_2 , is thus

$$\frac{Q_1}{Q_2} = \frac{D_1}{D_2} = \frac{\varepsilon_r \varepsilon_0 E}{\varepsilon_0 E} = \varepsilon_r, \quad (\text{P2.99})$$

and hence the portion of Q that is located on the upper half of the sphere amounts to

$$\frac{Q_2}{Q} = \frac{1}{\varepsilon_r + 1}. \quad (\text{P2.100})$$

PROBLEM 2.48 **Coaxial cable with two coaxial dielectric layers.** This is a cylindrical version of the structure in Fig.2.27, so Eq.(2.162) becomes

$$D(r) = \frac{Q'}{2\pi r}, \quad a < r < c, \quad (\text{P2.101})$$

and the voltage between the conductors of the coaxial cable in Fig.2.50 is

$$V = \int_{r=a}^b \frac{D(r)}{\varepsilon_1} dr + \int_{r=b}^c \frac{D(r)}{\varepsilon_2} dr = \frac{Q'}{2\pi} \left(\frac{1}{\varepsilon_1} \ln \frac{b}{a} + \frac{1}{\varepsilon_2} \ln \frac{c}{b} \right). \quad (\text{P2.102})$$

Hence, the capacitance per unit length of the cable amounts to

$$C' = \frac{Q'}{V} = 2\pi\varepsilon_0 \left(\frac{1}{\varepsilon_{r1}} \ln \frac{b}{a} + \frac{1}{\varepsilon_{r2}} \ln \frac{c}{b} \right)^{-1} = 114.7 \text{ pF/m}. \quad (\text{P2.103})$$

Alternatively, we can find C' of the cable in Fig.2.50 as the equivalent total p.u.l. capacitance of a series connection, Eq.(2.156), of two coaxial cables with homogeneous dielectrics, whose p.u.l. capacitances, from Eq.(2.123), are given by

$$C'_1 = \frac{2\pi\varepsilon_{r1}\varepsilon_0}{\ln(b/a)} \quad \text{and} \quad C'_2 = \frac{2\pi\varepsilon_{r2}\varepsilon_0}{\ln(c/b)}. \quad (\text{P2.104})$$

PROBLEM 2.49 **Coaxial cable with a radial variation of permittivity.**

(a) This, again, is a cylindrical version of the structure analyzed in Example 2.19. The electric flux density vector in the dielectric is radial with respect to the cable axis and its magnitude is given by $D(r) = Q'/(2\pi r)$. Similarly to the integration in Eq.(2.169), the voltage of the cable can be computed as

$$V = \int_a^b E(r) dr = \int_a^b \frac{D(r)}{\varepsilon_r(r)\varepsilon_0} dr = \frac{Q'}{2\pi\varepsilon_0} \int_a^b \frac{dr}{r\varepsilon_r(r)}, \quad (\text{P2.105})$$

and its per-unit-length capacitance as

$$C' = \frac{Q'}{V} = 2\pi\varepsilon_0 \left[\int_a^b \frac{dr}{r\varepsilon_r(r)} \right]^{-1} = \frac{2\pi\varepsilon_0 b}{b-a} = 69.54 \text{ pF/m}. \quad (\text{P2.106})$$

(b) The volume and surface bound charge densities in the dielectric are found as in Eqs.(2.170)-(2.172) [of course, here we use the formula for the divergence in cylindrical coordinates, Eq.(1.170), to compute ρ_p]:

$$\begin{aligned} P(r) &= \frac{\varepsilon_r(r) - 1}{\varepsilon_r(r)} D(r) = \frac{\varepsilon_r(r) - 1}{\varepsilon_r(r)} \frac{C'V}{2\pi r} = \frac{\varepsilon_0 bV}{b-a} \left(\frac{1}{r} - \frac{a}{r^2} \right) \\ \longrightarrow \quad \rho_p &= -\nabla \cdot \mathbf{P} = -\frac{1}{r} \frac{d}{dr} [rP(r)] = -\frac{\varepsilon_0 abV}{(b-a)r^3} = -\frac{5\varepsilon_0 aV}{4r^3}, \\ \rho_{psa} &= -P(a^+) = 0, \quad \rho_{psb} = P(b^-) = \frac{\varepsilon_0 V}{5a}. \end{aligned} \quad (\text{P2.107})$$

PROBLEM 2.50 **Coaxial cable with four dielectric sectors.** (a) This is the same type of structure as the one in Fig.2.30, and we can modify (specialize), according to the permittivity variation in Fig.2.51, either Eqs.(2.177) or just the final result – the expression for the capacitance per unit length of the cable in Eqs.(2.178) with the integral in ϕ , which now reduces to

$$C' = \frac{\int_0^{2\pi} \varepsilon(\phi) d\phi}{\ln(b/a)} = \frac{\varepsilon_{r1}\varepsilon_0\pi/2 + \varepsilon_{r2}\varepsilon_0\pi/2 + \varepsilon_{r3}\varepsilon_0\pi/2 + \varepsilon_{r4}\varepsilon_0\pi/2}{\ln(b/a)}$$

$$= \frac{\pi(\varepsilon_{r1} + \varepsilon_{r2} + \varepsilon_{r3} + \varepsilon_{r4})\varepsilon_0}{2\ln(b/a)} = 211 \text{ pF/m} . \quad (\text{P2.108})$$

(b) As explained in Example 2.21, the electric field intensity, $E(r)$, in the dielectric of the cable in Fig.2.51 is given in Eq.(2.124), so that its value near the inner conductor of the cable amounts to

$$E(a^+) = \frac{V}{a \ln(b/a)} = 9.978 \text{ kV/m} , \quad \text{for } 0 \leq \phi \leq 2\pi . \quad (\text{P2.109})$$

Similarly to Eqs.(2.179) and (2.180), the free surface charge densities on the inner conductor of the cable – for the notation in Fig.P2.12 – are:

$$\rho_{s1} = \varepsilon_{r1}\varepsilon_0 E(a^+) = 530 \text{ nC/m}^2 , \quad \rho_{s2} = \varepsilon_{r2}\varepsilon_0 E(a^+) = 176.7 \text{ nC/m}^2 ,$$

$$\rho_{s3} = \varepsilon_{r3}\varepsilon_0 E(a^+) = 88.35 \text{ nC/m}^2 , \quad \rho_{s4} = \varepsilon_{r4}\varepsilon_0 E(a^+) = 883.5 \text{ nC/m}^2 . \quad (\text{P2.110})$$

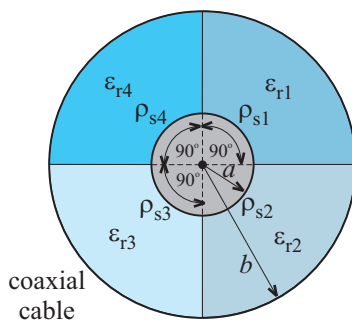

Figure P2.12 Free surface charge densities on the inner conductor of the coaxial cable in Fig.2.51 (cross section of the structure).

PROBLEM 2.51 **Charge distribution for two coated wires.** Since $d \gg a$ in Fig.2.31, we neglect the electric field due to the second conductor (which is far away) while computing the charge distributions near the first conductor and its dielectric coating, and vice versa.

(a) Using Eqs.(2.58), (2.181), and (2.183), the densities of free surface charges on the wire conductors, for the notation in Fig.P2.13, amount to

$$\rho_{s1} = D_1|_{\text{near wire 1}} = D_1(a^+) = \frac{Q'}{2\pi a} = \frac{C'V}{2\pi a} = 16.4 \text{ nC/m}^2 ,$$

$$\rho_{s2} = -D_2|_{\text{near wire 2}} = -\rho_{s1} = -16.4 \text{ nC/m}^2 \quad (C' = 10.3 \text{ pF/m}) . \quad (\text{P2.111})$$

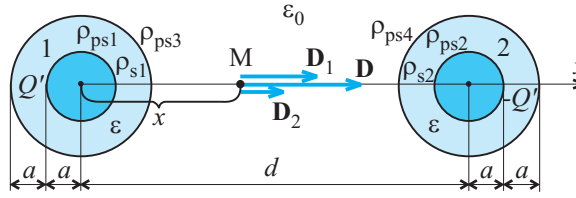

Figure P2.13 Free and bound surface charge densities in the thin two-wire line with dielectric coatings over conductors in Fig.2.31 (cross section of the structure).

(b) From Eq.(2.60), $\rho_p = 0$ (because $\rho = 0$) in the dielectric coatings. By means of Eqs.(2.61), (2.23), (2.59), and (2.47), the bound surface charge densities on individual surfaces of coatings (Fig.P2.13) are

$$\begin{aligned} \rho_{ps1} &= -\frac{\epsilon_r - 1}{\epsilon_r} \rho_{s1} = -12.3 \text{ nC/m}^2, & \rho_{ps2} &= -\rho_{ps1} = 12.3 \text{ nC/m}^2, \\ \rho_{ps3} &= P(2a^-) = \frac{\epsilon_r - 1}{\epsilon_r} D(2a^-) = \frac{\epsilon_r - 1}{\epsilon_r} \frac{Q'}{2\pi(2a)} = \frac{\epsilon_r - 1}{\epsilon_r} \frac{C'V}{4\pi a} = 6.15 \text{ nC/m}^2, \\ \rho_{ps4} &= -\rho_{ps3} = -6.15 \text{ nC/m}^2. \end{aligned} \quad (\text{P2.112})$$

PROBLEM 2.52 Two metallic spheres with dielectric coating. The voltage between the two dielectrically coated spheres can, since $d \gg a$, be computed as the voltage from the positively charged sphere to the reference point for potential (at infinity) plus the voltage from the reference point to the negatively charged sphere. By the same token, the capacitance between the two spheres (C of the associated capacitor) can be obtained as the equivalent capacitance of a series connection of two equal capacitors, using Eq.(2.156), so as

$$C = \frac{C_{\text{one sphere}} C_{\text{one sphere}}}{C_{\text{one sphere}} + C_{\text{one sphere}}} = \frac{C_{\text{one sphere}}}{2} = 1.112 \text{ pF}, \quad (\text{P2.113})$$

where $C_{\text{one sphere}}$ is the capacitance of one (isolated) metallic sphere with the dielectric coating (Fig.2.48), found in Problem 2.44. Of course, the same result (for voltage and capacitance) can be obtained by integrating the electric field vector, between the surfaces of the two metallic spheres, along the line connecting the centers of the two spheres, as in Fig.2.31.

PROBLEM 2.53 Two metallic spheres half embedded in a dielectric. (a) As in the previous problem, the capacitance of the capacitor in Fig.2.52 amounts to

$$C = \frac{C_{\text{one sphere}}}{2} = \pi(\epsilon_r + 1)\epsilon_0 a = 0.695 \text{ pF}, \quad (\text{P2.114})$$

with $C_{\text{one sphere}}$ now being the capacitance of one (isolated) metallic sphere (half embedded in a dielectric half-space) in Fig.2.49, computed in Problem 2.47.

(b)-(c) Because $d \gg a$, we evaluate the charge distributions on and near each of the metallic spheres in Fig.2.52 neglecting the electric field due to the other charged

electrode of the capacitor. Therefore, the electric field intensity $E(r)$ around each of the spheres can in this computation be considered to be that in Eq.(2.175), so

$$E(r) = \frac{Q}{2\pi(\epsilon_r + 1)\epsilon_0 r^2} = \frac{CV}{2\pi(\epsilon_r + 1)\epsilon_0 r^2} = \frac{aV}{2r^2}. \quad (\text{P2.115})$$

Using Eqs.(2.58), (2.60), (2.61), and (2.23), the free and bound charge densities in the system, for the notation in Fig.P2.14, are found to be

$$\begin{aligned} \rho_{s1} = \epsilon_r \epsilon_0 E(a^+) = \frac{\epsilon_r \epsilon_0 V}{2a} = 708 \text{ nC/m}^2, \quad \rho_{s2} = \epsilon_0 E(a^+) = \frac{\epsilon_0 V}{2a} = 177 \text{ nC/m}^2, \\ \rho_p = 0, \quad \rho_{ps1} = -\frac{\epsilon_r - 1}{\epsilon_r} \rho_{s1} = -531 \text{ nC/m}^2, \quad \rho_{ps2} = \rho_{ps3} = 0. \end{aligned} \quad (\text{P2.116})$$

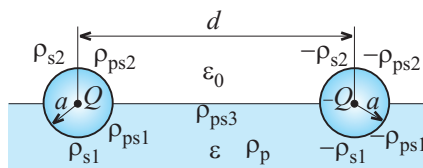

Figure P2.14 Free and bound charge densities in the system of two charged metallic spheres pressed into a dielectric half-space in Fig.2.52.

PROBLEM 2.54 **Permittivity gradient normal to capacitor plates.** Let us subdivide the dielectric into thin slices of thicknesses dx as shown in Fig.P2.15. As each thin layer (slice) can be considered as being homogeneous, of permittivity $\epsilon(x)$, it is obvious that this capacitor represents a D -system and, moreover, a generalization of the parallel-plate capacitor in Fig.2.25(a), which has only two such layers. Therefore, the electric flux density vector in all thin layers is the same, given by Eq.(2.147), with the fringing neglected, that is,

$$\mathbf{D} = D \hat{\mathbf{x}} = \frac{Q}{ab} \hat{\mathbf{x}} \quad (0 \leq x \leq d), \quad (\text{P2.117})$$

which can be confirmed, for instance, applying the generalized Gauss' law, Eq.(2.43), to a rectangular closed surface enclosing the first plate, with the right-hand side positioned in either one of the slices in Fig.P2.15. The electric field intensity vector in the dielectric is

$$\mathbf{E}(x) = \frac{D}{\epsilon(x)} \hat{\mathbf{x}} = \frac{Q}{\epsilon(x)ab} \hat{\mathbf{x}}. \quad (\text{P2.118})$$

The voltage of the capacitor amounts to

$$V = \int_{x=0}^d E(x) dx = \frac{Q}{ab} \int_0^d \frac{dx}{\epsilon(x)} = \frac{Q}{2\epsilon_0 ab} \int_0^d \frac{dx}{1 + 3x/d} = \frac{Qd \ln 4}{6\epsilon_0 ab}, \quad (\text{P2.119})$$

and its capacitance to

$$C = \frac{Q}{V} = \frac{6\epsilon_0 ab}{d \ln 4}. \quad (\text{P2.120})$$

Alternatively, this capacitance can be obtained by modeling each thin layer in Fig.P2.15 (boundary surfaces between layers can be metalized) by a parallel-plate capacitor with a homogeneous dielectric, plate separation dx , and capacitance [Eq.(2.127)]

$$C_{\text{thin layer}} = \epsilon(x) \frac{ab}{dx} \quad (0 \leq x \leq d). \quad (\text{P2.121})$$

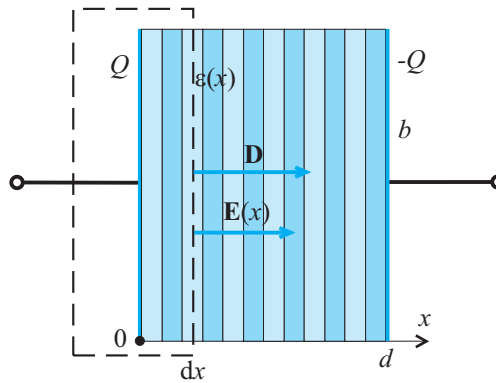

Figure P2.15 Analysis of a parallel-plate capacitor with dielectric permittivity gradient normal to plates [$\varepsilon = \varepsilon(x)$ in Fig.2.53].

Of course, all these capacitors are connected in series, and, in the equivalent circuit representing a generalization of the circuit in Fig.2.26(a), the equivalent resultant capacitance of such a connection equals, having Eqs.(2.155) and (2.156) in mind, the inverse of the sum (integral) of the inverses of individual capacitances,

$$\frac{1}{C} = \int_{x=0}^d \frac{1}{C_{\text{thin layer}}} = \int_0^d \frac{dx}{\varepsilon(x)ab} = \frac{1}{2\varepsilon_0 ab} \int_0^d \frac{dx}{1 + 3x/d} = \frac{d \ln 4}{6\varepsilon_0 ab}. \quad (\text{P2.122})$$

PROBLEM 2.55 **Permittivity gradient parallel to capacitor plates.** We now subdivide the dielectric into thin layers of thicknesses dy as depicted in Fig.P2.16, where each such layer can be considered as being homogeneous, of permittivity $\varepsilon(y)$, which implies that this is an E -system representing a generalization of the parallel-plate capacitor with two homogeneous layers in Fig.2.25(b). The electric field intensity vector in all layers, in both capacitors, equals [Eq.(2.151)]

$$\mathbf{E} = E \hat{\mathbf{x}} = \frac{V}{d} \hat{\mathbf{x}} \quad (0 \leq y \leq b), \quad (\text{P2.123})$$

and the electric flux density vector is

$$\mathbf{D}(y) = \varepsilon(y)E \hat{\mathbf{x}} = \frac{\varepsilon(y)V}{d} \hat{\mathbf{x}}. \quad (\text{P2.124})$$

The generalized Gauss' law applied to a rectangular box surface positioned about the first plate (Fig.P2.16) yields

$$\int_{y=0}^b D(y) \underbrace{a dy}_{dS} = Q \quad \longrightarrow \quad \frac{aV}{d} \int_0^b \varepsilon(y) dy = Q, \quad (\text{P2.125})$$

where dS is the area of an elemental strip of length a and width dy , and Q is the charge of the capacitor, and hence the capacitance of the capacitor

$$C = \frac{Q}{V} = \frac{a}{d} \int_0^b \varepsilon(y) dy = \frac{2\varepsilon_0 a}{d} \int_0^b \left[1 + 3 \sin\left(\frac{\pi}{b} y\right) \right] dy = \frac{2(\pi + 6)\varepsilon_0 ab}{\pi d}. \quad (\text{P2.126})$$

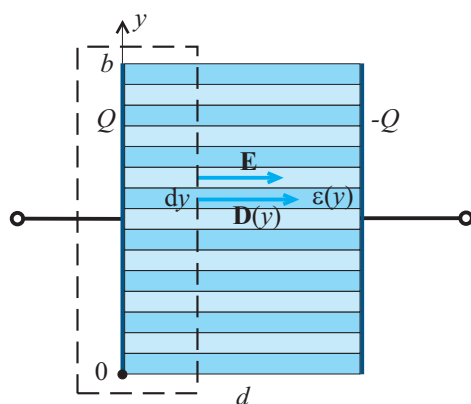

Figure P2.16 Analysis of a parallel-plate capacitor with dielectric permittivity gradient parallel to plates [$\varepsilon = \varepsilon(y)$ in Fig.2.53].

An alternative approach based on an equivalent circuit as in Fig.2.26(b) is also possible, where every thin layer in Fig.P2.16 is modeled by an elementary parallel-plate capacitor with a homogeneous dielectric, plate area $a \, dy$, and plate separation d , whose capacitance, from Eq.(2.127), is

$$dC = \varepsilon(y) \frac{a \, dy}{d} \quad (0 \leq y \leq b). \quad (\text{P2.127})$$

According to Eq.(2.159), the total capacitance of the parallel connection of all the elementary capacitors amounts to

$$C = \int_{y=0}^b dC = \int_0^b \varepsilon(y) \frac{a \, dy}{d} = \frac{2(\pi + 6)\varepsilon_0 ab}{\pi d}. \quad (\text{P2.128})$$

PROBLEM 2.56 Capacitor with a nonlinear dielectric layer. (a)-(b)

This is similar to Example 2.23. Referring to Fig.P2.17, the condition $V = 0$ across the capacitor (it is short-circuited) gives

$$Ed + E_0 d = 0 \quad \longrightarrow \quad E = -E_0. \quad (\text{P2.129})$$

From the boundary condition for the normal components of the vector \mathbf{D} in Eq.(2.81), applied to the interface between the air-filled region and the ferroelectric layer in Fig.P2.17, midway between the capacitor plates, we have

$$D_0 = D. \quad (\text{P2.130})$$

Air is a linear medium and the relationship between \mathbf{D} and \mathbf{E} in Eq.(2.51) holds true. The ferroelectric is nonlinear and the relationship in Eq.(2.47) cannot be used, but we can invoke the definition of \mathbf{D} in Eq.(2.41), so that Eq.(P2.130) becomes

$$\varepsilon_0 E_0 = \varepsilon_0 E + P. \quad (\text{P2.131})$$

Solving Eqs.(P2.129) and (P2.131), we obtain $E_0 = P/(2\varepsilon_0)$ (in air) and $E = -P/(2\varepsilon_0)$ (in the dielectric).

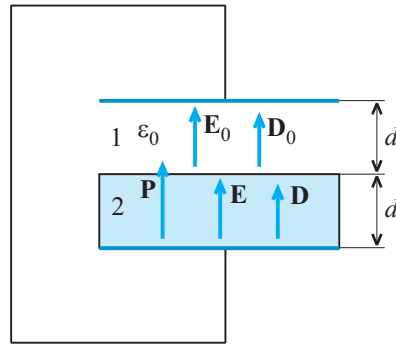

Figure P2.17 Electric field intensities and flux densities in the nonlinear dielectric layer and air region of the short-circuited parallel-plate capacitor in Fig.2.54.

Section 2.16 Electric Energy Density

PROBLEM 2.57 **Energy of a spherical capacitor with two layers.** (a) Based on Eqs.(2.202), (2.199), and (2.162), the electric energy stored in the inner dielectric layer in Fig.2.27 is obtained by integrating the electric energy density, w_{e1} , over the volume (v_1) of this layer as follows:

$$\begin{aligned} W_{e1} &= \int_{v_1} w_{e1} dv = \int_{r=a}^b \frac{D(r)^2}{2\varepsilon_1} \underbrace{4\pi r^2 dr}_{dv} = \int_a^b \frac{Q^2}{2\varepsilon_1(4\pi r^2)^2} 4\pi r^2 dr \\ &= \frac{Q^2}{8\pi\varepsilon_1} \left(\frac{1}{a} - \frac{1}{b} \right) = \frac{(b-a)Q^2}{8\pi\varepsilon_{r1}\varepsilon_0 ab} = 194.5 \text{ pJ}, \end{aligned} \quad (\text{P2.132})$$

where dv is adopted in the form of a thin spherical shell of radius r and thickness dr , Eq.(1.33), and Q is the charge of the capacitor, computed in Eq.(2.164). Similarly, the electric energy of the outer dielectric layer comes out to be

$$W_{e2} = \int_{v_2} w_{e2} dv = \int_b^c \frac{D(r)^2}{2\varepsilon_2} 4\pi r^2 dr = \frac{(c-b)Q^2}{8\pi\varepsilon_{r2}\varepsilon_0 bc} = 74.1 \text{ pJ}. \quad (\text{P2.133})$$

(b) Alternatively, the energies in each of the dielectric layers can be found by representing the capacitor as a series connection [Fig.2.26(a)] of two spherical capacitors with homogeneous dielectrics, whose capacitances, C_1 and C_2 , corresponding to the individual layers, are given in Eqs.(2.165). Thus, using Eq.(2.192), we have

$$W_{e1} = \frac{Q^2}{2C_1} = \frac{(b-a)Q^2}{8\pi\varepsilon_{r1}\varepsilon_0 ab} = 194.5 \text{ pJ} \quad \text{and} \quad W_{e2} = \frac{Q^2}{2C_2} = \frac{(c-b)Q^2}{8\pi\varepsilon_{r2}\varepsilon_0 bc} = 74.1 \text{ pJ}. \quad (\text{P2.134})$$

PROBLEM 2.58 Change in energy of a spherical capacitor. With the use of Eq.(2.192), the change in electric energy of the capacitor between the two electrostatic states turns out to be

$$\Delta W_e = (W_e)_{\text{new}} - (W_e)_{\text{old}} = \frac{1}{2} Q V_{\text{new}} - \frac{1}{2} Q V_{\text{source}} = \frac{1}{2} Q (V_{\text{new}} - V_{\text{source}}) = 21 \text{ nJ}, \quad (\text{P2.135})$$

where $Q = 1.152 \text{ nC}$, $V_{\text{new}} = 136.5 \text{ V}$, and $V_{\text{source}} = 100 \text{ V}$ (Problem 2.42).

PROBLEM 2.59 Energy of a coated metallic sphere. We can metalize the equipotential surface $r = b$ in the structure in Fig.2.48 and thus obtain two spherical capacitors, with electrode radii of the second (air-filled) one being b and $c \rightarrow \infty$. Based on Eq.(2.192), the electric energies stored in the dielectric coating and in air in Fig.2.48 can then, respectively, be expressed as

$$W_{e1} = \frac{Q^2}{2C_1} \quad \text{and} \quad W_{e2} = \frac{Q^2}{2C_2}, \quad (\text{P2.136})$$

where the charges of the two capacitors in the equivalent circuit in Fig.2.26(a) are the same, Q , and their capacitances are obtained from Eqs.(2.165) specifying $\epsilon_{r1} = \epsilon_r$, $\epsilon_{r2} = 1$, and $c \rightarrow \infty$:

$$C_1 = \frac{4\pi\epsilon_r\epsilon_0 ab}{b-a} \quad \text{and} \quad C_2 = 4\pi\epsilon_0 b. \quad (\text{P2.137})$$

The required equality of two energies in Eqs.(P2.136), i.e., the requirement that 1/2 of the total energy of the system is stored in the coating, implies the equality of the capacitances in Eqs(P2.137), which further leads to

$$W_{e1} = W_{e2} \quad \longrightarrow \quad C_1 = C_2 \quad \longrightarrow \quad \frac{\epsilon_r a}{b-a} = 1 \quad \longrightarrow \quad b = (\epsilon_r + 1) a = 5 \text{ cm}. \quad (\text{P2.138})$$

PROBLEM 2.60 Energy of a coaxial cable with two coaxial layers. This is a cylindrical version of the energy computation in Problem 2.57.

(a) Having in mind Eqs.(2.206) and (2.207) and the expression for the electric flux density in the cable dielectric, $D(r) = Q'/(2\pi r)$, we compute the electric energy stored in the inner dielectric layer in Fig.2.50 per unit length of the coaxial cable by integrating the electric energy density over the cross-sectional areas of the individual layers, S_1 and S_2 , which results in

$$\begin{aligned} W'_{e1} &= \int_{S_1} w_{e1} dS = \int_{r=a}^b \frac{D(r)^2}{2\epsilon_1} \underbrace{2\pi r dr}_{dS} = \int_a^b \frac{Q'^2}{2\epsilon_1(2\pi r)^2} 2\pi r dr = \frac{Q'^2}{4\pi\epsilon_1\epsilon_0} \ln \frac{b}{a} \\ &= 164 \text{ nJ/m}, \quad W'_{e2} = \int_{S_2} w_{e2} dS = \int_b^c \frac{D(r)^2}{2\epsilon_2} 2\pi r dr = \frac{Q'^2}{4\pi\epsilon_2\epsilon_0} \ln \frac{c}{b} = 409 \text{ nJ/m}, \end{aligned} \quad (\text{P2.139})$$

where dS is the area of an elementary ring (adopted for integration) of radius r and width dr , Eq.(1.60), $Q' = C'V$, and $C' = 114.7 \text{ pF/m}$ is the capacitance per unit length of the cable, found in Problem 2.48.

(b) In the alternative approach, we represent the cable by the equivalent circuit in Fig.2.26(a) and use the p.u.l. capacitances $C'_1 = 2\pi\epsilon_1\epsilon_0/\ln(b/a)$ and $C'_2 =$

$2\pi\varepsilon_{r2}\varepsilon_0/\ln(c/b)$ (Problem 2.48), to obtain [see also Eq.(2.208)]

$$W'_{e1} = \frac{Q'^2}{2C'_1} = \frac{Q'^2}{4\pi\varepsilon_{r1}\varepsilon_0} \ln \frac{b}{a} = 164 \text{ nJ/m}, \quad W'_{e2} = \frac{Q'^2}{2C'_2} = \frac{Q'^2}{4\pi\varepsilon_{r2}\varepsilon_0} \ln \frac{c}{b} = 409 \text{ nJ/m}. \quad (\text{P2.140})$$

PROBLEM 2.61 **Energy of a half-filled spherical capacitor.** This is a spherical version of the energy computation in Example 2.26. With the electric field intensity $E(r)$ in the capacitor in Fig.2.29 given in Eq.(2.175), the electric energy contained in the liquid, i.e., in the lower half of the space between electrodes (volume v_1), is computed as

$$\begin{aligned} W_{e1} &= \int_{v_1} w_{e1} dv = \int_{r=a}^b \underbrace{\frac{1}{2} \varepsilon_r \varepsilon_0 E(r)^2}_{w_{e1}} \underbrace{2\pi r^2 dr}_{dv} = \int_a^b \frac{1}{2} \varepsilon_r \varepsilon_0 \frac{Q^2}{[2\pi(\varepsilon_r + 1)\varepsilon_0 r^2]^2} 2\pi r^2 dr \\ &= \frac{\varepsilon_r(b-a)Q^2}{4\pi(\varepsilon_r + 1)^2 \varepsilon_0 ab}, \end{aligned} \quad (\text{P2.141})$$

where dv is the volume of a thin hemispherical shell of radius r and thickness dr [$1/2$ of dv in Eq.(1.33)].

PROBLEM 2.62 **Energy of a coaxial cable with four sectors.** Like the coaxial cable in Fig.2.33, this is an E -system, and the electric field (\mathbf{E}) is the same as in the air-filled coaxial cable, Eq.(2.124). Similarly to the energy computation in Eq.(2.210), the per-unit-length electric energy contained in the 90° dielectric sector of relative permittivity ε_{r1} ($\varepsilon_{r1} = 6$) in Fig.2.51 is found to be

$$\begin{aligned} E(r) = \frac{V}{r \ln(b/a)} \quad \longrightarrow \quad W'_{e1} &= \int_{r=a}^b \underbrace{\frac{1}{2} \varepsilon_1 E(r)^2}_{w_{e1}} \underbrace{\frac{\pi}{2} r dr}_{dS_1} = \frac{\pi \varepsilon_{r1} \varepsilon_0 V^2}{4 \ln^2(b/a)} \int_a^b \frac{dr}{r} \\ &= \frac{\pi \varepsilon_{r1} \varepsilon_0 V^2}{4 \ln(b/a)} = 20.82 \text{ nJ/m}, \end{aligned} \quad (\text{P2.142})$$

with dS_1 standing for the surface area of a quarter (determined by the angle $\pi/2$) of a thin ring of radius r and width dr [dS_1 is $1/4$ of dS in Eq.(1.60)]. In the same way, the p.u.l. energies in the remaining three 90° dielectric sectors in Fig.2.51 are

$$\begin{aligned} W'_{e2} &= \frac{\pi \varepsilon_{r2} \varepsilon_0 V^2}{4 \ln(b/a)} = 6.94 \text{ nJ/m}, \quad W'_{e3} = \frac{\pi \varepsilon_{r3} \varepsilon_0 V^2}{4 \ln(b/a)} = 3.47 \text{ nJ/m}, \\ W'_{e4} &= \frac{\pi \varepsilon_{r4} \varepsilon_0 V^2}{4 \ln(b/a)} = 34.7 \text{ nJ/m}. \end{aligned} \quad (\text{P2.143})$$

PROBLEM 2.63 **Energy of a capacitor with a variable permittivity.** Based on Eqs.(2.202) and (2.199) and the fact that $D = \text{const}$ in the capacitor

dielectric (Problem 2.54), the total electric energy of the capacitor (W_e) can be computed as

$$W_e = \int_v w_e dv = \int_{x=0}^d \frac{D^2}{2\varepsilon(x)} \underbrace{ab dx}_{dv} = \frac{abD^2}{2} \int_0^d \frac{dx}{\varepsilon(x)} = \frac{abD^2}{4\varepsilon_0} \int_0^d \frac{dx}{1+3x/d}, \quad (\text{P2.144})$$

where dv is adopted in the form of a thin flat layer (slice) of thickness dx . By the same token, the energy contained in the first half (from $x = 0$ to $x = d/2$) of the dielectric, W_{e1} , can be obtained by replacing the upper limit (d) in the above integrals by $d/2$. Hence, the percentage of W_e contained in the first half of the dielectric turns out to be

$$\frac{W_{e1}}{W_e} = \frac{\int_0^{d/2} \frac{dx}{1+3x/d}}{\int_0^d \frac{dx}{1+3x/d}} = \frac{\ln(5/2)}{\ln 4} = 66.1\%. \quad (\text{P2.145})$$

PROBLEM 2.64 Energy of a capacitor with an inhomogeneous dielectric. Given that now $E = \text{const}$ in the dielectric of the capacitor (Problem 2.55), we have

$$\begin{aligned} W_e &= \int_v w_e dv = \int_{y=0}^b \frac{1}{2} \varepsilon(y) E^2 \underbrace{ad dy}_{dv} = \frac{adE^2}{2} \int_0^b \varepsilon(y) dy \\ &= \varepsilon_0 adE^2 \int_0^b \left[1 + 3 \sin\left(\frac{\pi}{b} y\right) \right] dy, \end{aligned} \quad (\text{P2.146})$$

so that the percentage of this energy stored in the lower half of the dielectric (from $y = 0$ to $y = b/2$) amounts to

$$\frac{W_{e1}}{W_e} = \frac{\int_0^{b/2} [1 + 3 \sin(\pi y/b)] dy}{\int_0^b [1 + 3 \sin(\pi y/b)] dy} = \frac{1/2 + 3/\pi}{1 + 6/\pi} = 50\%. \quad (\text{P2.147})$$

PROBLEM 2.65 Energy of a system of spherical conductors. Using Eq.(2.195), the energy of the system of three spherical conductors in Fig.1.56, in which the third (outer) conductor is grounded (its potential is zero) and for which the charges of the inner and middle conductors are, respectively, $Q_1 = 1.85 \text{ pC}$ and $Q_2 = 24.85 \text{ pC}$ (Problem 1.80), is given by

$$W_e = \frac{1}{2} (Q_1 V_1 + Q_2 V_2 + Q_3 V_3) = \frac{1}{2} (Q_1 V_1 + Q_2 V_2) = 138 \text{ pJ} \quad (V_3 = 0). \quad (\text{P2.148})$$

PROBLEM 2.66 Energy of a system of flat electrodes. (a) Using the electric field intensities between electrodes in the electrostatic system in Fig.1.42, found in Example 1.28, the electric energy stored in the system is

$$W_e = \underbrace{\frac{1}{2} \varepsilon_0 E_1^2}_{w_{e1}} \underbrace{Sd}_{v_1} + \frac{1}{2} \varepsilon_0 E_2^2 Sd + \frac{1}{2} \varepsilon_0 E_3^2 Sd + \frac{1}{2} \varepsilon_0 E_4^2 Sd$$

$$= \frac{\varepsilon_0 S d}{2} (E_1^2 + E_2^2 + E_3^2) = 3.587 \text{ mJ} \quad (E_4 = 0) . \quad (\text{P2.149})$$

(b) Using the equivalent circuit in Fig.2.47, for which the capacitances and charges are computed in Problem 2.40, the energy of the system equals

$$W_e = \frac{Q_1^2}{2C_1} + \frac{Q_2^2}{2C_2} + \frac{Q_3^2}{2C_3} = \frac{1}{2C_1} (Q_1^2 + Q_2^2 + Q_3^2) = 3.587 \text{ mJ} \quad (Q_4 = 0) , \quad (\text{P2.150})$$

which, of course, is the same result as in Eq.(P2.149).

PROBLEM 2.67 Energy of a system with free volume charge. The electric flux density in the dielectric cylinder is given by $D(r) = \rho r/2$ (Problem 2.14), and, similarly to the computation in Eqs.(2.213), (2.206), and (2.207), the electric energy stored in the cylinder per unit of its length is found to be

$$W'_{e1} = \int_{r=0}^a w_e(r) \underbrace{2\pi r \, dr}_{dS} = \int_0^a \frac{D(r)^2}{2\varepsilon_r \varepsilon_0} 2\pi r \, dr = \frac{\pi \rho^2}{4\varepsilon_r \varepsilon_0} \int_0^a r^3 \, dr = \frac{\pi \rho^2 a^4}{16\varepsilon_r \varepsilon_0} , \quad (\text{P2.151})$$

with dS being the area of an elementary ring of radius r and width dr , Eq.(1.60), in the cross section of the cylinder. The electric field and flux density in air (outside the cylinder), from Gauss' law, are proportional to $1/r$, and an integration like that in Eq.(P2.151) results in $W'_{e2} \rightarrow \infty$ for the total per-unit-length energy contained in the field outside the cylinder. This means that such a charged cylinder cannot exist alone in space; in fact, the sum of all charges p.u.l. of very long metallic/dielectric systems in reality must be zero, as expressed by Eq.(11.27) in the field analysis of transmission lines.

PROBLEM 2.68 Energy of a pn junction. This is a planar version of the energy calculation in Example 2.27.

The first way to calculate the electric energy contained in the pn junction is to use Eq.(2.202) and the electric field expressions in Eqs.(2.74) and (2.75), as follows:

$$\begin{aligned} W_e &= \int_v w_e \, dv = \int_{x=-\infty}^{\infty} \frac{1}{2} \varepsilon E_x(x)^2 \underbrace{S \, dx}_{dv} \\ &= \frac{\rho_0^2 a^2 S}{2\varepsilon} \left(\int_{-\infty}^0 e^{2x/a} \, dx + \int_0^{\infty} e^{-2x/a} \, dx \right) = \frac{\rho_0^2 a^3 S}{2\varepsilon} , \end{aligned} \quad (\text{P2.152})$$

where dv is an elementary volume for integration adopted in the form of a slice of thickness dx across the junction [S is the area of the junction cross section perpendicular to the x -axis in Fig.2.9(a)].

The second way is to employ Eq.(2.196) in a combination with the charge density and potential expressions in Eqs.(2.69) and (2.76)-(2.77), respectively,

$$\begin{aligned} W_e &= \frac{1}{2} \int_v \rho V \, dv = \frac{1}{2} \int_{x=-\infty}^{\infty} \rho(x) V(x) \underbrace{S \, dx}_{dv} \\ &= \frac{\rho_0^2 a^2 S}{2\varepsilon} \left[\int_{-\infty}^0 (-e^{x/a}) (e^{x/a} - 1) \, dx + \int_0^{\infty} e^{-x/a} (1 - e^{-x/a}) \, dx \right] = \frac{\rho_0^2 a^3 S}{2\varepsilon} . \end{aligned} \quad (\text{P2.153})$$

Of course, the results are the same.

Section 2.17 Dielectric Breakdown in Electrostatic Systems

PROBLEM 2.69 Breakdown charge and energy of the earth. Based on Eq.(1.193), dielectric breakdown of air near the earth's surface occurs when

$$E(a^+) = \frac{Q}{4\pi\epsilon_0 a^2} = E_{cr0} = 3 \text{ MV/m}, \quad a = R = 6378 \text{ km} \quad (\text{P2.154})$$

[E_{cr0} is the dielectric strength of air, Eq.(2.53)], from which, and Eq.(2.192) and the fact that $C_{\text{earth}} = 709.6 \mu\text{F}$ (Problem 2.25), the maximum possible charge and electric energy that could be stored on the earth turn out to be

$$Q = 4\pi\epsilon_0 R^2 E_{cr0} = 1.36 \times 10^{10} \text{ C} \quad \text{and} \quad W_e = \frac{Q^2}{2C} = 1.3 \times 10^{23} \text{ J}, \quad (\text{P2.155})$$

respectively.

PROBLEM 2.70 Maximum breakdown voltage of a spherical capacitor. This is a spherical version of Example 2.29.

(a) Having in mind Eq.(2.117), the critical charge of the capacitor, at breakdown, is given by

$$E(a^+) = \frac{Q}{4\pi\epsilon_r\epsilon_0 a^2} = E_{cr} \quad \longrightarrow \quad Q_{cr} = 4\pi\epsilon_r\epsilon_0 a^2 E_{cr}. \quad (\text{P2.156})$$

Employing also Eq.(2.119), the breakdown voltage of the capacitor, for a given radius a , is

$$V_{cr}(a) = \frac{Q}{C} = -\frac{E_{cr}}{b} a^2 + E_{cr} a. \quad (\text{P2.157})$$

To optimize a such that V_{cr} is maximum, assuming that b is fixed, we equate to zero the derivative of V_{cr} with respect to a , which yields

$$\frac{dV_{cr}}{da} = 0 \quad \longrightarrow \quad E_{cr} \left(-\frac{2}{b} a + 1 \right) = 0 \quad \longrightarrow \quad a_{opt} = \frac{b}{2} = 5 \text{ cm}. \quad (\text{P2.158})$$

As the second derivative of $V_{cr}(a)$ for $a = a_{opt}$ is negative (equals $-2E_{cr}/b$), this is indeed a maximum (and not a minimum) of the function.

(b) The maximum breakdown voltage of the capacitor amounts to

$$(V_{cr})_{\max} = V_{cr}(a_{opt}) = \frac{E_{cr} b}{4} = 625 \text{ kV}. \quad (\text{P2.159})$$

(c) The corresponding value of the capacitor energy is

$$W_e = \frac{1}{2} C (V_{cr})_{\max}^2 = \frac{1}{2} \frac{4\pi\epsilon_r\epsilon_0 a_{opt} b}{b - a_{opt}} \frac{E_{cr}^2 b^2}{16} = \frac{\pi\epsilon_r\epsilon_0 b^3 E_{cr}^2}{8} = 10.87 \text{ J}. \quad (\text{P2.160})$$

PROBLEM 2.71 Breakdown in a wire-plane transmission line. (a) The electric field intensity of the wire-plane transmission line, in Fig.2.24(a), is the largest very close to the surface of the wire conductor, where it is given by Eq.(2.224). Namely, from the analysis in Problem 1.88, on the other side, the maximum field intensity near the ground plane, that straight below the wire (for $x = 0$), is

$$(E_{\text{near plane}})_{\text{max}} = \frac{Q'}{\varepsilon_0 \pi h} \ll \frac{Q'}{2\pi \varepsilon_0 a} \quad (a \ll h). \quad (\text{P2.161})$$

The capacitance per unit length of the line (C') is computed in Eq.(2.146), so that the breakdown voltage of the line equals

$$\begin{aligned} E_{\text{max}} = \frac{Q'_{\text{cr}}}{2\pi \varepsilon_0 a} = E_{\text{cr}0} = 3 \text{ MV/m} &\longrightarrow V_{\text{cr}} = \frac{Q'_{\text{cr}}}{C'} = \frac{Q'_{\text{cr}}}{2\pi \varepsilon_0} \ln \frac{2h}{a} \\ &= a E_{\text{cr}0} \ln \frac{2h}{a} = 159 \text{ kV}. \end{aligned} \quad (\text{P2.162})$$

(b) The maximum energy per unit length of the line is

$$W'_e = \frac{1}{2} C' V_{\text{cr}}^2 = \frac{\pi \varepsilon_0 V_{\text{cr}}^2}{\ln(2h/a)} = 132.6 \text{ mJ/m}. \quad (\text{P2.163})$$

(c) Using Eqs.(1.224), the largest possible electric force on the wire conductor in Fig.2.24(a) per unit of its length comes out to be

$$F'_e = \frac{Q_{\text{cr}}'^2}{4\pi \varepsilon_0 h} = \frac{(2\pi \varepsilon_0 a E_{\text{cr}0})^2}{4\pi \varepsilon_0 h} = \frac{\pi \varepsilon_0 a^2 E_{\text{cr}0}^2}{h} = 25 \text{ mN/m}. \quad (\text{P2.164})$$

PROBLEM 2.72 Grounded metallic sphere as a lightning arrester. (a) With Q denoting the charge of the grounded small ($a \ll h$) metallic sphere, as shown in Fig.P2.18, the potential of the sphere due to Q and its image in the conducting plane with respect to the plane, that is, the voltage between the surface of the sphere and the plane (point 3 in Fig.P2.18), equals a half of the voltage between the sphere and its image, so $1/2$ of the voltage between two small metallic spheres in air computed in Problem 2.34. It thus equals $Q/(4\pi \varepsilon_0 a)$, so that the total potential V_1 at point 1 in Fig.P2.18 is given, in place of Eq.(2.228), by

$$V_1 = \frac{Q}{4\pi \varepsilon_0 a} - E_0 h. \quad (\text{P2.165})$$

The condition that the sphere is grounded then yields

$$V_1 = 0 \longrightarrow Q = 4\pi \varepsilon_0 E_0 a h. \quad (\text{P2.166})$$

(b) Since $h \gg a$, the electric field intensity on the surface of the sphere can be evaluated using Eq.(1.193), neglecting the field due to the image of Q ,

$$E_1 = \frac{Q}{4\pi \varepsilon_0 a^2} = \frac{E_0 h}{a} = 1200 E_0. \quad (\text{P2.167})$$

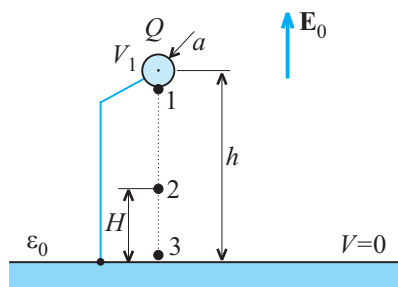

Figure P2.18 Grounded small metallic sphere in a uniform atmospheric electric field above the surface of the earth (lightning arrester).

(c) Based on the electric field expression from Problem 2.34, the field intensities at points 2 ($H = 2$ m) and 3 in Fig.P2.18 amount, for the reference direction of \mathbf{E}_2 upward, to

$$E_2 = -\frac{Q}{4\pi\epsilon_0} \left[\frac{1}{r^2} + \frac{1}{(2h-r)^2} \right] + E_0 = 0.9977E_0 \quad (r = h - H)$$

$$\text{and } E_3 = -\frac{Q}{2\pi\epsilon_0 h^2} + E_0 = 0.9983E_0 \quad (r = h), \quad (\text{P2.168})$$

respectively.

Paralleling the computation in Eqs.(2.233), the field intensities E_2 and E_3 corresponding to an eventual breakdown (in a thunderstorm) near the metallic sphere in Fig.P2.18 [Eq.(2.232)] turn out to be

$$E_2 = 0.9977E_0 = \frac{0.9977}{1200} E_1 = \frac{E_{\text{cr}0}}{1202.8}, \quad E_3 = 0.9983E_0 = \frac{0.9833}{1200} E_1 = \frac{E_{\text{cr}0}}{1202}, \quad (\text{P2.169})$$

and they confirm the protective property of the grounded metallic sphere, serving principally as a lightning arrester, in the same way as the grounded wire conductor in Fig.2.34.

PROBLEM 2.73 Parallel-plate capacitor with two dielectric layers.

From Eq.(2.147), we obtain the following relationship between the electric field intensities in the two dielectric layers in Fig.2.25(a):

$$\epsilon_{r1}E_1 = \epsilon_{r2}E_2. \quad (\text{P2.170})$$

Let us first assume that, for a high enough voltage V of the capacitor, a breakdown occurs in the first layer, which implies that $E_1 = E_{\text{cr}1} = 20$ MV/m. At the same time, Eq.(2.236) gives $E_2 = \epsilon_{r1}E_1/\epsilon_{r2} = 12$ MV/m $>$ $E_{\text{cr}2} = 11$ MV/m, which is impossible. We conclude that the second dielectric layer of the capacitor must break down first, in which case

$$E_2 = E_{\text{cr}2} = 11 \text{ MV/m} \quad \text{and} \quad E_1 = \frac{\epsilon_{r2}}{\epsilon_{r1}} E_2 = 18.33 \text{ MV/m}. \quad (\text{P2.171})$$

The breakdown voltage of the capacitor is thus

$$V_{\text{cr}} = E_1 d_1 + E_2 d_2 = 80.67 \text{ kV}. \quad (\text{P2.172})$$

PROBLEM 2.74 Parallel-plate capacitor with two dielectric sectors.

The electric field intensities in the two dielectric sectors in Fig.2.25(b) are the same, Eq.(2.151), so it is obvious that, after a voltage of critical value is applied across the capacitor plates, a breakdown will occur in the second sector (with a smaller E_{cr}). The corresponding field values are

$$E_2 = E_{cr2} = 11 \text{ MV/m} \quad \text{and} \quad E_1 = E_2 = 11 \text{ MV/m} < E_{cr1} = 20 \text{ MV/m} , \quad (\text{P2.173})$$

and the capacitor breakdown voltage comes out to be

$$V_{cr} = E_1 d = 66 \text{ kV} . \quad (\text{P2.174})$$

PROBLEM 2.75 Breakdown in a spherical capacitor with two layers.

(a) If the inner dielectric layer of the spherical capacitor in Fig.2.27 is made from mica and the outer layer is oil, Eqs.(2.241) give

$$Q_{cr}^{(1)} = 4\pi\epsilon_{r1}\epsilon_0 a^2 E_{cr1} = 48.07 \mu\text{C} \quad \text{and} \quad Q_{cr}^{(2)} = 4\pi\epsilon_{r2}\epsilon_0 b^2 E_{cr2} = 24.57 \mu\text{C} . \quad (\text{P2.175})$$

This means [see Eq.(2.242)] that the breakdown (for sufficiently high applied voltage across the capacitor) occurs in the outer dielectric layer, and the breakdown value of the capacitor charge amounts to

$$Q_{cr} = Q_{cr}^{(2)} = 24.57 \mu\text{C} . \quad (\text{P2.176})$$

The breakdown voltage is

$$V_{cr} = \frac{Q_{cr}}{C_{old}} = 2.134 \text{ MV} , \quad (\text{P2.177})$$

where $C_{old} = 11.52 \text{ pF}$ is the capacitance of the capacitor in the first (old) electrostatic state (Problem 2.42).

(b) After the oil is drained from the capacitor, so that the outer dielectric layer is now air, the second charge in Eqs.(P2.175) becomes

$$Q_{cr}^{(2)} = 4\pi\epsilon_0 b^2 E_{cr0} = 2.14 \mu\text{C} \quad (\epsilon_{r2} = 1 , E_{cr0} = 3 \text{ MV/m}) , \quad (\text{P2.178})$$

indicating that the outer layer breaks down first, again. However, the breakdown voltage changes, to

$$Q_{cr} = Q_{cr}^{(2)} = 2.14 \mu\text{C} \quad \longrightarrow \quad V_{cr} = \frac{Q_{cr}}{C_{new}} = 253.7 \text{ kV} , \quad (\text{P2.179})$$

with $C_{new} = 8.44 \text{ pF}$ being the capacitance of the capacitor in the new state (Problem 2.42).

PROBLEM 2.76 Breakdown potential of a coated metallic sphere. (a)-(b) For breakdown considerations, the value of the radius c in Fig.2.27 is actually irrelevant, so it can even be $c \rightarrow \infty$; hence, we can reuse the expressions $Q_{\text{cr}}^{(1)} = 4\pi\epsilon_{\text{r1}}\epsilon_0 a^2 E_{\text{cr1}}$ and $Q_{\text{cr}}^{(2)} = 4\pi\epsilon_0 b^2 E_{\text{cr0}}$ from the previous problem (for a spherical capacitor with air as the second dielectric layer), which result in $Q_{\text{cr}}^{(1)} = 1.33 \mu\text{C}$ and $Q_{\text{cr}}^{(2)} = 0.3 \mu\text{C}$. We conclude that the breakdown would occur in air, near the interface with the dielectric coating of the metallic sphere, and $Q_{\text{cr}} = Q_{\text{cr}}^{(2)} = 0.3 \mu\text{C}$ [Eq.(2.242)]. Using the capacitance of the sphere computed in Problem 2.44, $C = 2.224 \text{ pF}$, the breakdown potential of the sphere and the maximum electric energy of this structure are

$$V_{\text{cr}} = \frac{Q_{\text{cr}}}{C} = 135 \text{ kV} \quad \text{and} \quad W_{\text{e}} = \frac{Q_{\text{cr}}^2}{2C} = 20.2 \text{ mJ} , \quad (\text{P2.180})$$

respectively.

PROBLEM 2.77 Breakdown in a coaxial cable with two layers. (a) Let us pursue the first way (based on the direct evaluation of the electric field intensities at characteristic locations in the structure) of the breakdown analysis presented for a spherical capacitor with a two-layer dielectric in Example 2.32. For the coaxial cable in Fig.2.50, Eqs.(2.234) and (2.235) take the following form:

$$E_1(r) = \frac{Q'}{2\pi\epsilon_{\text{r1}}\epsilon_0 r} = E_1(a^+) \frac{a}{r} \quad (a < r < b) , \quad (\text{P2.181})$$

$$E_2(r) = \frac{Q'}{2\pi\epsilon_{\text{r2}}\epsilon_0 r} = E_2(b^+) \frac{b}{r} \quad (b < r < c) , \quad (\text{P2.182})$$

and hence the relationship

$$\epsilon_{\text{r1}} a E_1(a^+) = \epsilon_{\text{r2}} b E_2(b^+) . \quad (\text{P2.183})$$

An assumption that a breakdown occurs in the inner layer leads to

$$E_1(a^+) = E_{\text{cr1}} = 40 \text{ MV/m} \quad \longrightarrow \quad E_2(b^+) = E_{\text{cr1}} \frac{\epsilon_{\text{r1}} a}{\epsilon_{\text{r2}} b} = 50 \text{ MV/m} > E_{\text{cr2}} , \quad (\text{P2.184})$$

which is impossible. Hence, an eventual breakdown must be in the outer layer,

$$E_2(b^+) = E_{\text{cr2}} = 20 \text{ MV/m} \quad \longrightarrow \quad E_1(a^+) = E_{\text{cr2}} \frac{\epsilon_{\text{r2}} b}{\epsilon_{\text{r1}} a} = 16 \text{ MV/m} < E_{\text{cr1}} . \quad (\text{P2.185})$$

Similarly to Eq.(2.240), the breakdown voltage of the cable is computed, using the field-intensity values in Eqs.(P2.185), as

$$V_{\text{cr}} = E_1(a^+) a \int_a^b \frac{dr}{r} + E_2(b^+) b \int_b^c \frac{dr}{r} = \epsilon_{\text{r2}} b E_{\text{cr2}} \left(\frac{1}{\epsilon_{\text{r1}}} \ln \frac{b}{a} + \frac{1}{\epsilon_{\text{r2}}} \ln \frac{c}{b} \right) = 38.8 \text{ kV} . \quad (\text{P2.186})$$

(b) The maximum energy that the cable can store per unit of its length amounts to

$$W'_{\text{e}} = \frac{1}{2} C' V_{\text{cr}}^2 = 86.4 \text{ mJ/m} , \quad (\text{P2.187})$$

where $C' = 114.7$ pF/m is the capacitance p.u.l. of the cable, found in Problem 2.48.

PROBLEM 2.78 Simultaneous breakdown in two spherical layers. For a sufficiently large applied voltage, dielectric breakdown will occur in both dielectric layers in the capacitor in Fig.2.27 simultaneously if the two values of charges $Q_{\text{cr}}^{(1)}$ and $Q_{\text{cr}}^{(2)}$ in Eqs.(2.241) are the same, which condition results in the following relationship between the parameters of the capacitor:

$$Q_{\text{cr}}^{(1)} = Q_{\text{cr}}^{(2)} \quad \longrightarrow \quad \varepsilon_{\text{r}1}a^2E_{\text{cr}1} = \varepsilon_{\text{r}2}b^2E_{\text{cr}2} . \quad (\text{P2.188})$$

PROBLEM 2.79 Simultaneous breakdown in two coaxial layers. Let us consider the critical value, for breakdown, of the charge Q' per unit length of the coaxial cable in Fig.2.50, and denote by $Q'_{\text{cr}1}$ and $Q'_{\text{cr}2}$ the charge Q' in the case of an eventual breakdown in the inner and outer dielectric layers, respectively, of the cable. Based on the breakdown analysis in Problem 2.77, we then obtain the following expressions for these charges, analogous to those in Eqs.(2.241) for the corresponding spherical capacitor:

$$Q'_{\text{cr}1} = 2\pi\varepsilon_{\text{r}1}\varepsilon_0aE_{\text{cr}1} \quad \text{and} \quad Q'_{\text{cr}2} = 2\pi\varepsilon_{\text{r}2}\varepsilon_0bE_{\text{cr}2} . \quad (\text{P2.189})$$

Hence, we conclude that the breakdown will occur in both dielectric layers in Fig.2.50 simultaneously if

$$Q'_{\text{cr}1} = Q'_{\text{cr}2} \quad \longrightarrow \quad \varepsilon_{\text{r}1}aE_{\text{cr}1} = \varepsilon_{\text{r}2}bE_{\text{cr}2} . \quad (\text{P2.190})$$

PROBLEM 2.80 Metallic sphere half immersed in a liquid dielectric. Denoting by V_{cr} the maximum potential of the metallic sphere in Fig.2.49 such that dielectric breakdown will not occur after it is removed from the liquid and raised in air high above the interface, the corresponding critical value of the charge of the sphere, using the expression for its capacitance from Problem 2.47, turns out to be

$$Q_{\text{cr}} = CV_{\text{cr}} = 2\pi(\varepsilon_{\text{r}} + 1)\varepsilon_0aV_{\text{cr}} . \quad (\text{P2.191})$$

This charge remains the same upon the elevation of the sphere above the liquid.

In the new electrostatic state, assuming that the sphere is isolated in air (as it is high above the interface), the condition for a breakdown near the sphere surface, expressed as in Problem 2.69, actually determines the value of Q_{cr} , as follows:

$$Q_{\text{cr}} = 4\pi\varepsilon_0a^2E_{\text{cr}0} \quad (E_{\text{cr}0} = 3 \text{ MV/m}) . \quad (\text{P2.192})$$

Substituted back in Eq.(P2.191), for the first electrostatic state, it leads to

$$V_{\text{cr}} = \frac{2aE_{\text{cr}0}}{\varepsilon_{\text{r}} + 1} = 30 \text{ kV} . \quad (\text{P2.193})$$

Finally, we need yet to check whether the system in Fig.2.49 is safe from breakdown in the first state. The electric field intensity near the sphere surface in both the liquid and air is, from Eqs.(2.175) and (P2.192),

$$E(a^+) = \frac{Q_{\text{cr}}}{2\pi(\epsilon_r + 1)\epsilon_0 a^2} = \frac{2E_{\text{cr}0}}{\epsilon_r + 1} = \frac{E_{\text{cr}0}}{2} = 1.5 \text{ MV/m} . \quad (\text{P2.194})$$

Since $E(a^+) < E_{\text{cr}0}$ (for air) and $E(a^+) < E_{\text{cr}} = 20 \text{ MV/m}$ (for the liquid dielectric), we conclude that setting the sphere to the potential V_{cr} or charging it with Q_{cr} while half in the liquid (in the first state) will not cause breakdown of the system, which will occur only after the sphere is raised in air.

PROBLEM 2.81 Breakdown in a coaxial cable with a dielectric spacer.

(a) The electric field intensity near the inner conductor of the cable in Fig.2.33 is given by the expression in Eq.(2.218). This, for $r = a^+$, is the largest electric field intensity in the cable. Since it is the same in both the dielectric spacer and the air-filled part of the cable interior, an eventual dielectric breakdown will occur in air ($E_{\text{cr}0} < E_{\text{cr}}$), if

$$E(a^+) = \frac{V_{\text{cr}}}{a \ln(b/a)} = E_{\text{cr}0} = 3 \text{ MV/m} , \quad (\text{P2.195})$$

and hence the breakdown voltage of the cable

$$V_{\text{cr}} = E_{\text{cr}0} a \ln \frac{b}{a} = 6.59 \text{ kV} . \quad (\text{P2.196})$$

(b) Having in mind Eqs.(2.178), as well as the capacitance found in Problem 2.50, the capacitance per unit length of the cable (Fig.2.33) is

$$C' = \frac{\epsilon_r \epsilon_0 \alpha + \epsilon_0 (2\pi - \alpha)}{\ln(b/a)} = \frac{(\epsilon_r \pi/3 + 5\pi/3) \epsilon_0}{\ln(b/a)} = 84.4 \text{ pF/m} , \quad (\text{P2.197})$$

so that the electric energy per unit length of the cable at breakdown amounts to

$$W'_e = \frac{1}{2} C' V_{\text{cr}}^2 = 1.83 \text{ mJ/m} . \quad (\text{P2.198})$$
