

## Ch. 2 Linear and Quadratic Functions

### 2.1 Properties of Linear Functions and Linear Models

#### 1 Graph Linear Functions

**MULTIPLE CHOICE.** Choose the one alternative that best completes the statement or answers the question.

Determine the slope and y-intercept of the function.

1)  $f(x) = 11x - 8$

A)  $m = 11; b = -8$

B)  $m = 11; b = 8$

C)  $m = -11; b = -8$

D)  $m = -11; b = 8$

2)  $h(x) = -8x + 1$

A)  $m = -8; b = 1$

B)  $m = 8; b = -1$

C)  $m = 8; b = 1$

D)  $m = -8; b = -1$

3)  $p(x) = -x - 10$

A)  $m = -1; b = -10$

B)  $m = 1; b = 10$

C)  $m = -1; b = 10$

D)  $m = 0; b = -10$

4)  $f(x) = -9x - \frac{3}{2}$

A)  $m = -9; b = -\frac{3}{2}$

B)  $m = -\frac{3}{2}; b = -9$

C)  $m = -\frac{1}{9}; b = \frac{3}{2}$

D)  $m = 9; b = \frac{3}{2}$

5)  $F(x) = -10$

A)  $m = 0; b = -10$

B)  $m = -10; b = 0$

C)  $m = 0; b = 0$

D)  $m = -10; b = -10$

6)  $G(x) = 3x$

A)  $m = 3; b = 0$

B)  $m = -3; b = 0$

C)  $m = \frac{1}{3}; b = 0$

D)  $m = 0; b = 3$

7)  $F(x) = -\frac{1}{4}x$

A)  $m = -\frac{1}{4}; b = 0$

B)  $m = -4; b = 0$

C)  $m = \frac{1}{4}; b = 0$

D)  $m = 0; b = -\frac{1}{4}$

Use the slope and y-intercept to graph the linear function.

8)  $f(x) = 3x - 3$

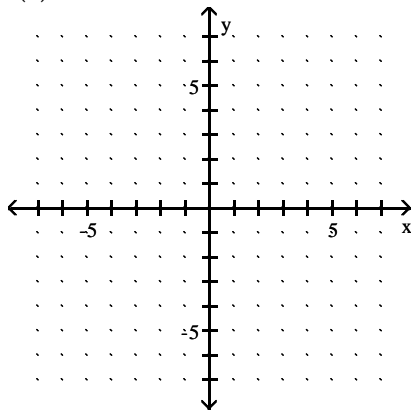

A)

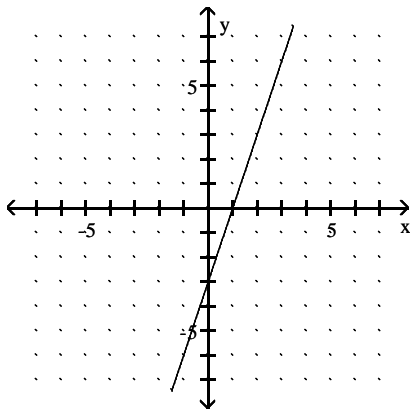

B)

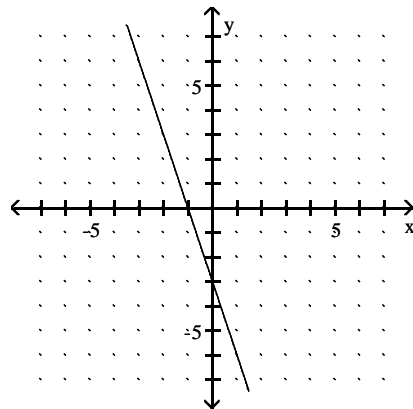

C)

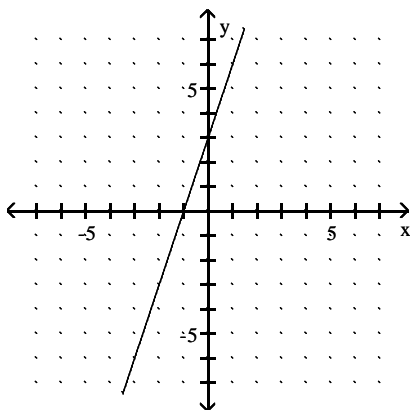

D)

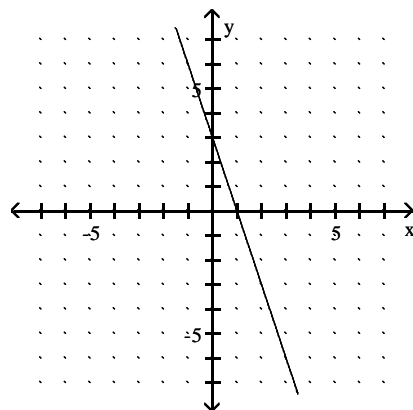

9)  $g(x) = -2x + 3$

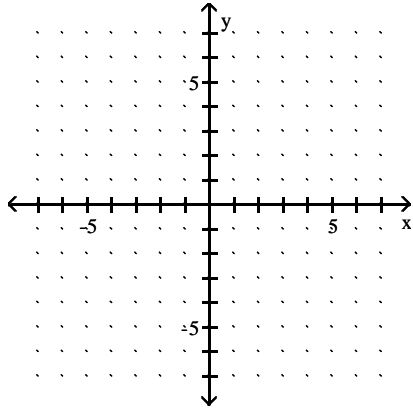

A)

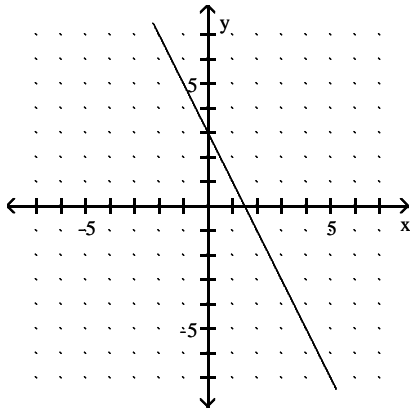

B)

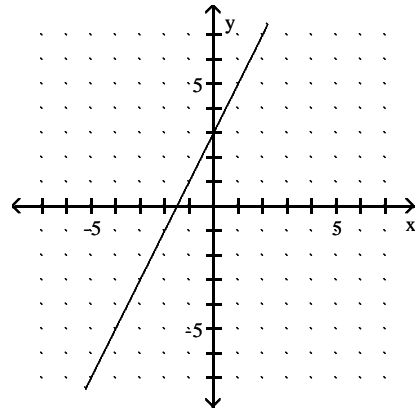

C)

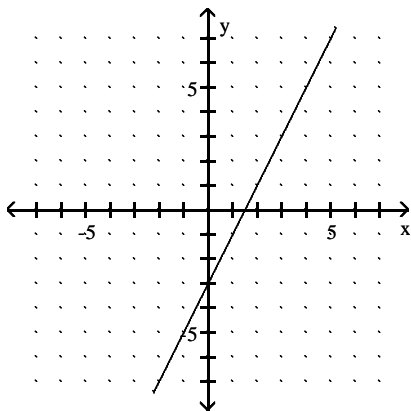

D)

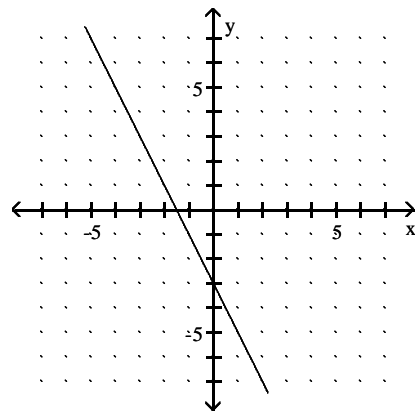

10)  $p(x) = -x + 5$

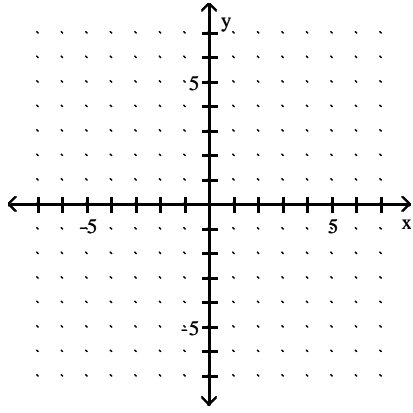

A)

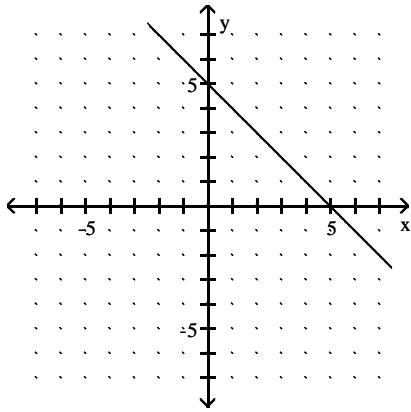

B)

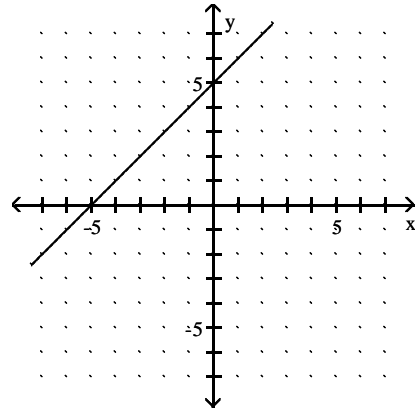

C)

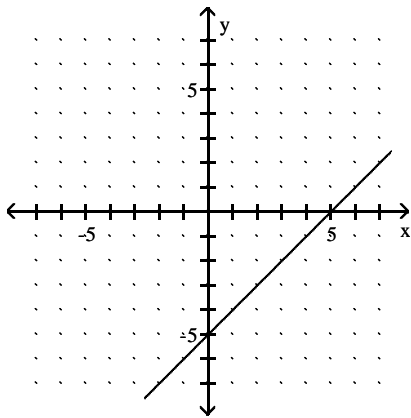

D)

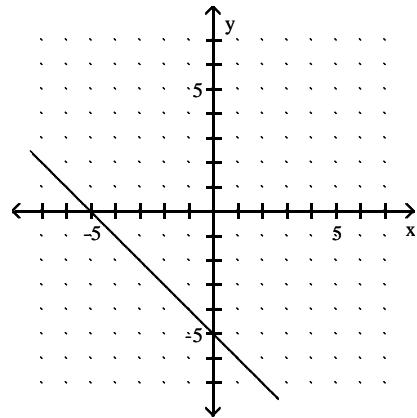

11)  $f(x) = \frac{1}{2}x + 1$

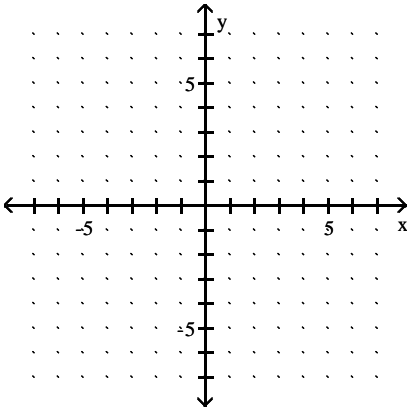

A)

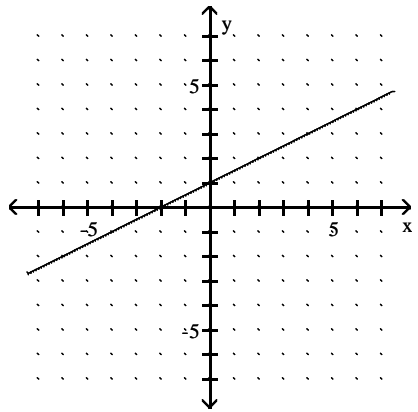

B)

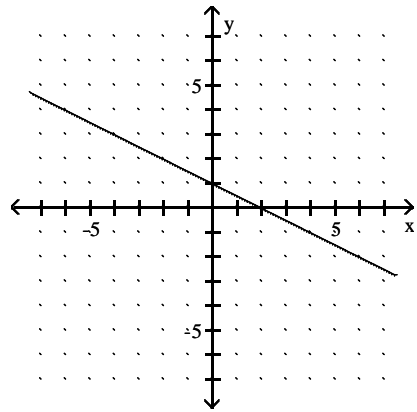

C)

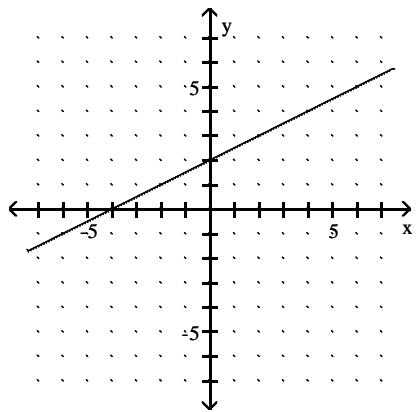

D)

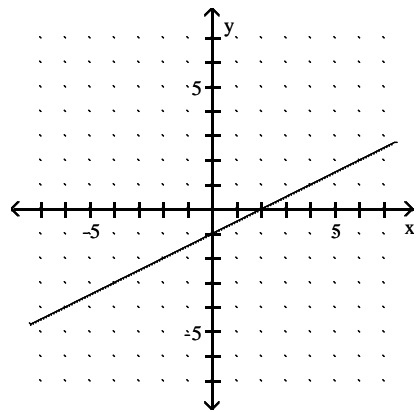

12)  $h(x) = -\frac{3}{4}x + 3$

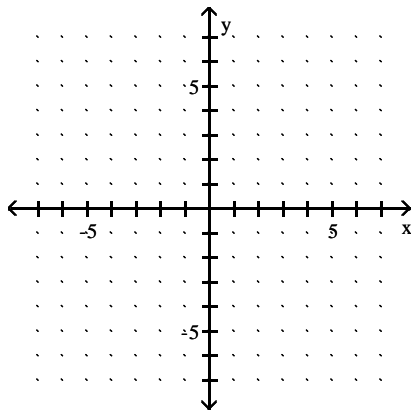

A)

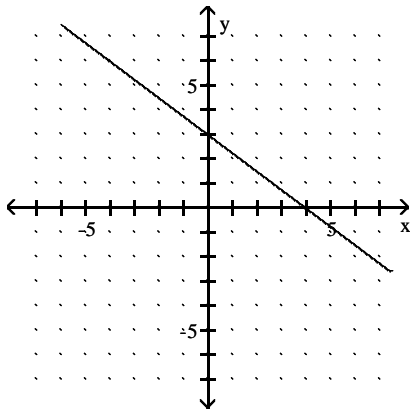

B)

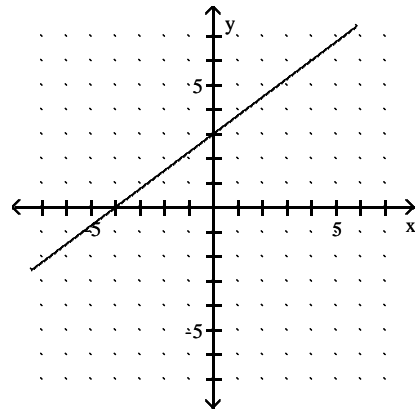

C)

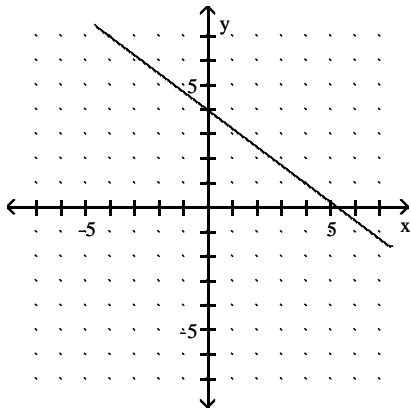

D)

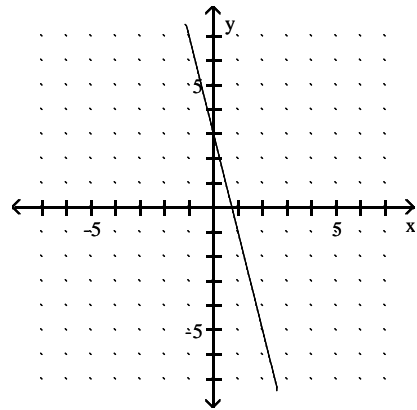

13)  $F(x) = 3$

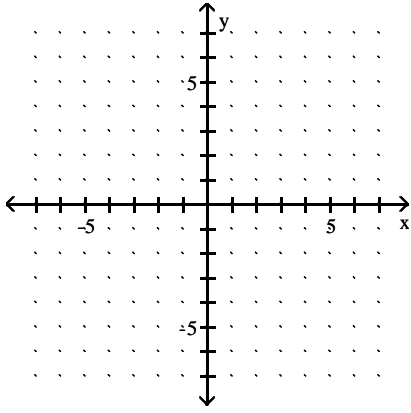

A)

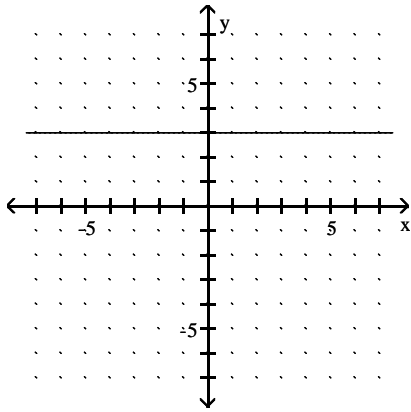

C)

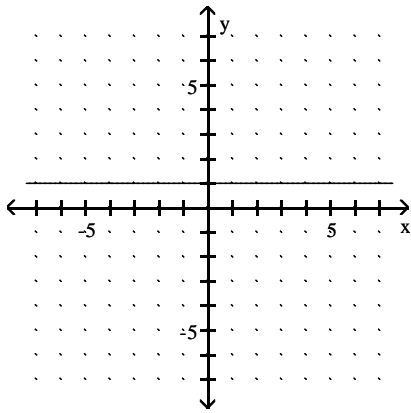

B)

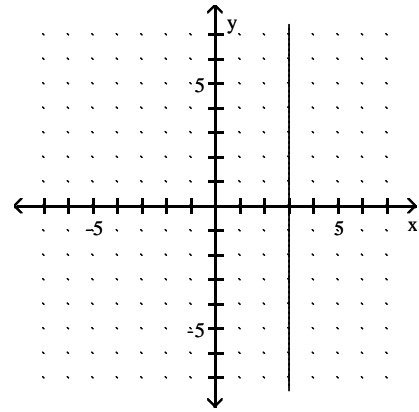

D)

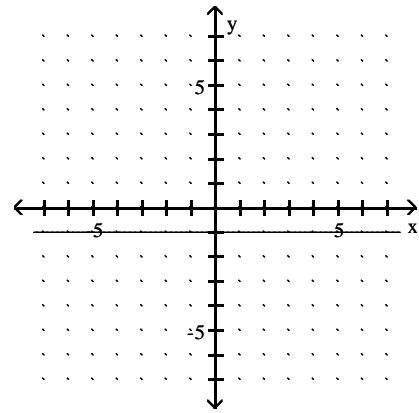

14)  $G(x) = -5x$

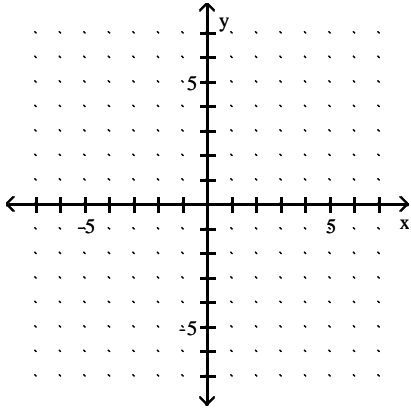

A)

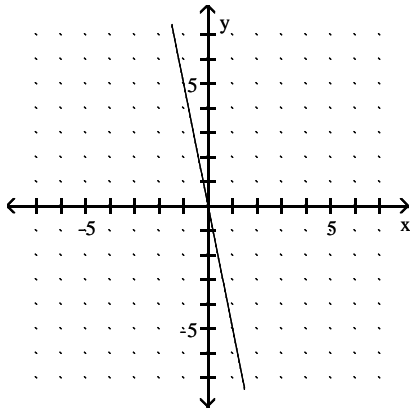

B)

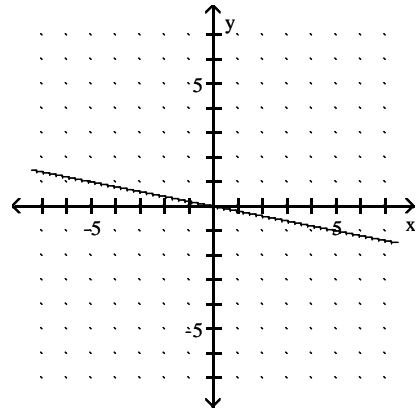

C)

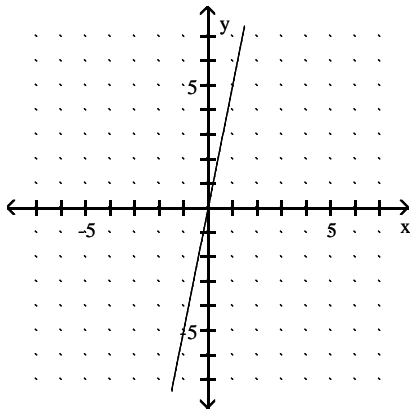

D)

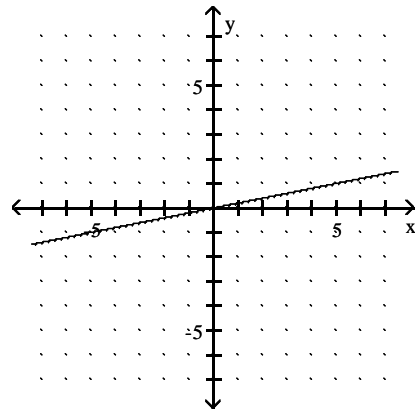



15)  $F(x) = \frac{1}{6}x$

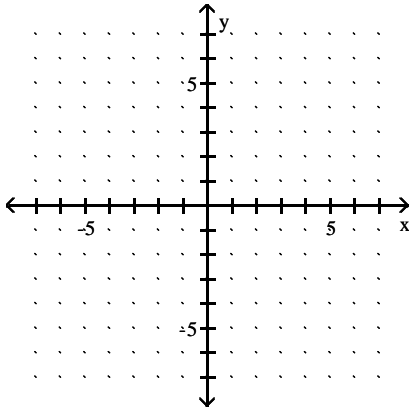

A)

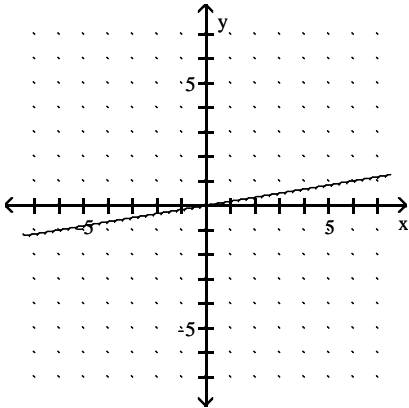

C)

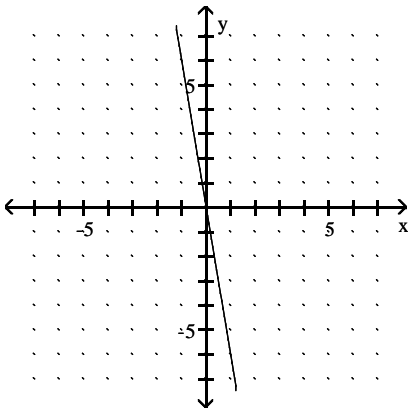

B)

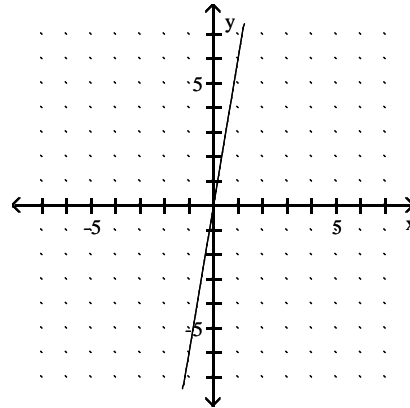

D)

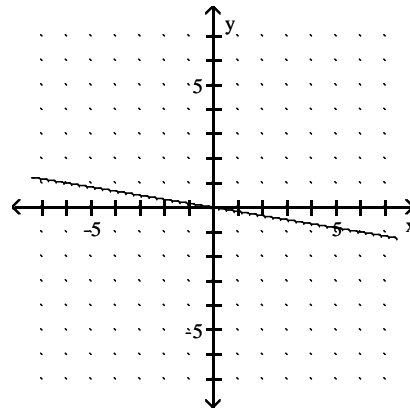

Determine whether the given function is linear or nonlinear.

16)

x	y = f(x)
4	20
7	35
10	50
13	65

A) linear

B) nonlinear

## 2 Use Average Rate of Change to Identify Linear Functions

**MULTIPLE CHOICE.** Choose the one alternative that best completes the statement or answers the question.

**Determine the average rate of change for the function.**

1)  $f(x) = 3x + 12$

A) 3

B) -12

C) 12

D) -3

2)  $h(x) = -8x + 9$

A) -8

B) 8

C) 9

D) -9

3)  $p(x) = -x - 6$

A) -1

B) 1

C) 6

D) -6

4)  $F(x) = -8$

A) 0

B)  $-\frac{1}{8}$

C) 8

D) -8

5)  $f(x) = \frac{1}{2}x - 2$

A)  $\frac{1}{2}$

B)  $-\frac{1}{2}$

C) -2

D) 2

6)  $h(x) = -\frac{1}{2}x + 2$

A)  $-\frac{1}{2}$

B)  $\frac{1}{2}$

C) 2

D) -2

### 3 Determine Whether a Linear Function is Increasing, Decreasing, or Constant

MULTIPLE CHOICE. Choose the one alternative that best completes the statement or answers the question.

Graph the function. State whether it is increasing, decreasing, or constant..

1)  $f(x) = 2x + 3$

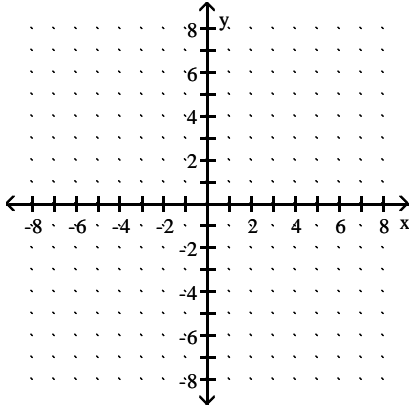

A) increasing

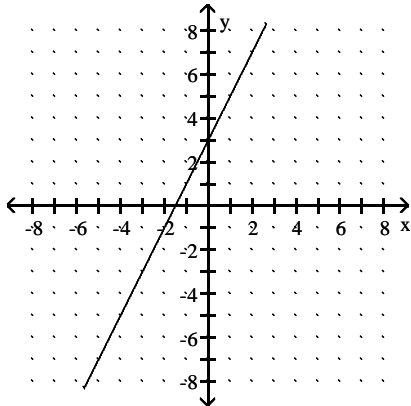

B) increasing

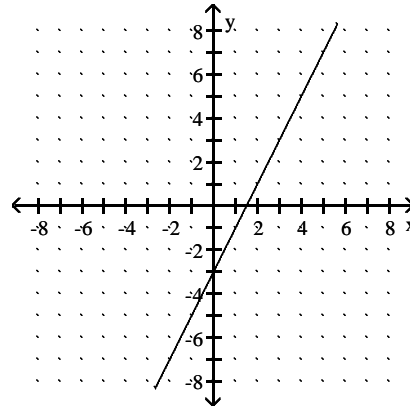

C) decreasing

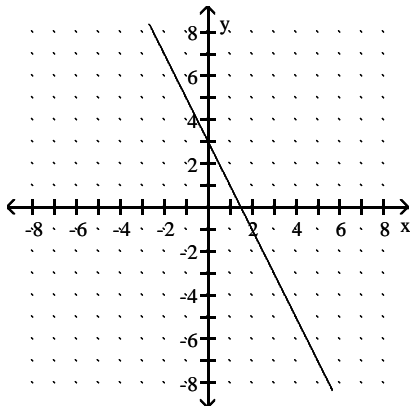

D) increasing

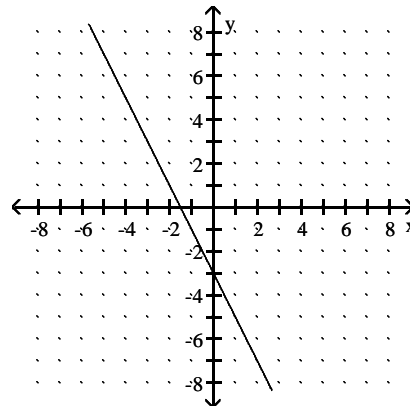

2)  $g(x) = 5x - 3$

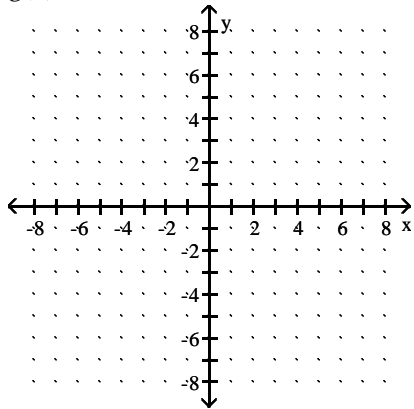

A) increasing

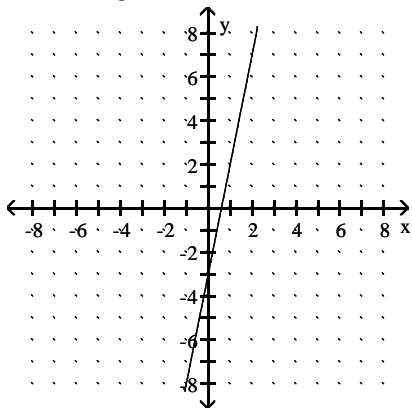

B) increasing

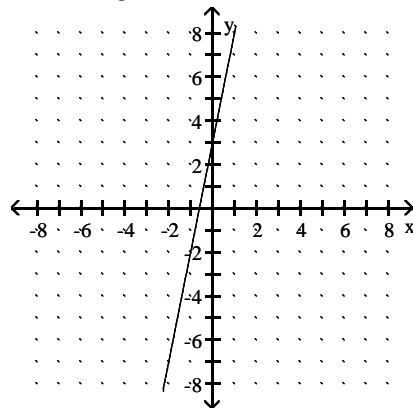

C) decreasing

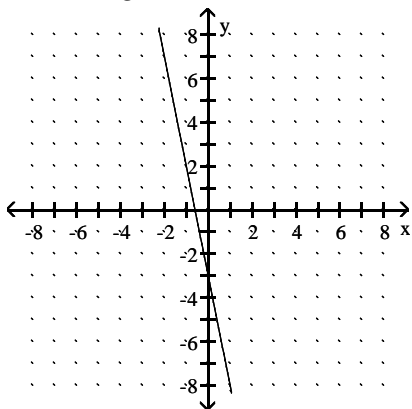

D) decreasing

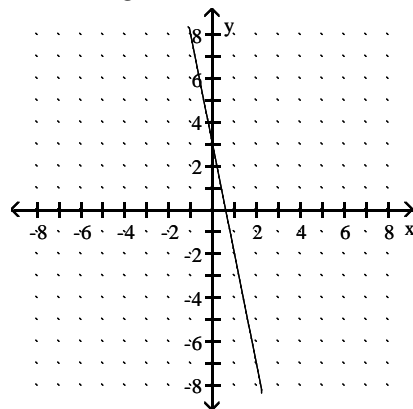

3)  $h(x) = -2x + 4$

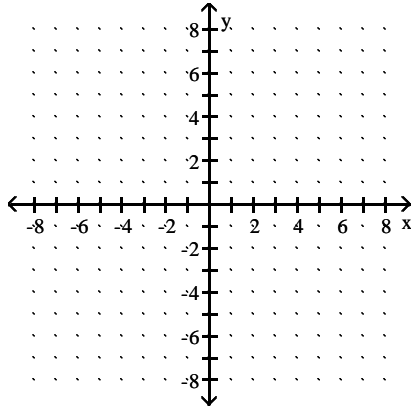

A) decreasing

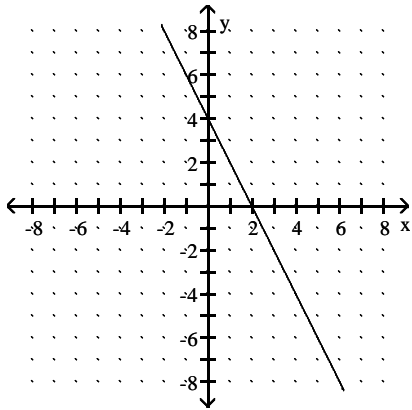

B) decreasing

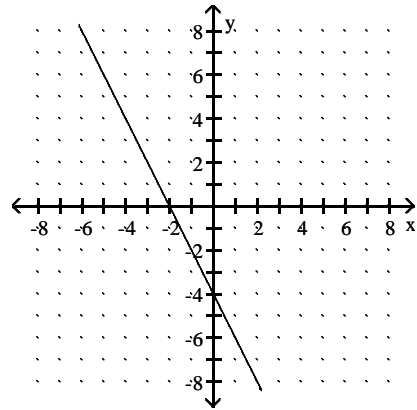

C) increasing

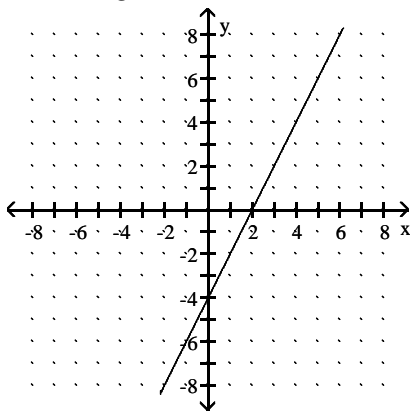

D) increasing

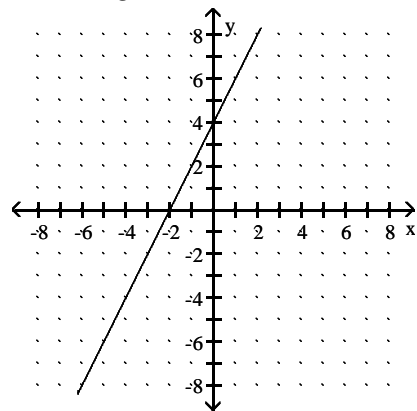

4)  $h(x) = -3x - 6$

A) decreasing

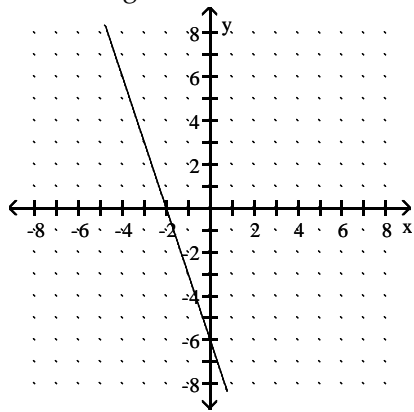

B) decreasing

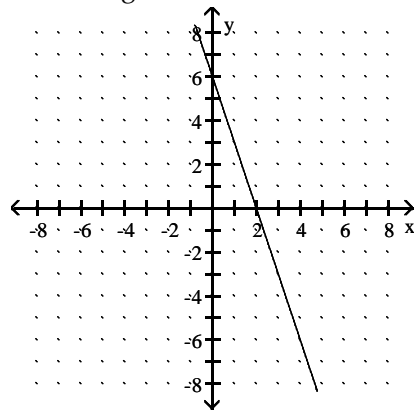

C) increasing

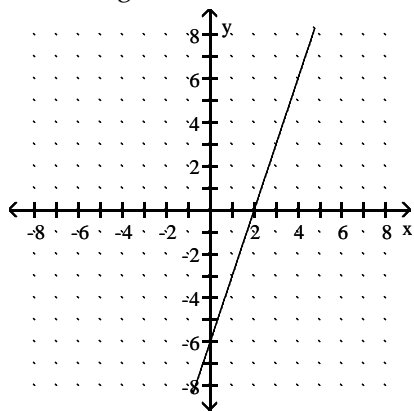

D) increasing

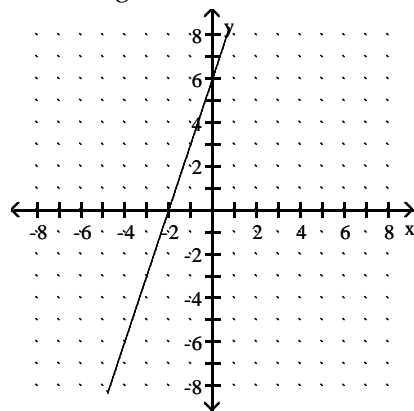

5)  $p(x) = -x - 4$

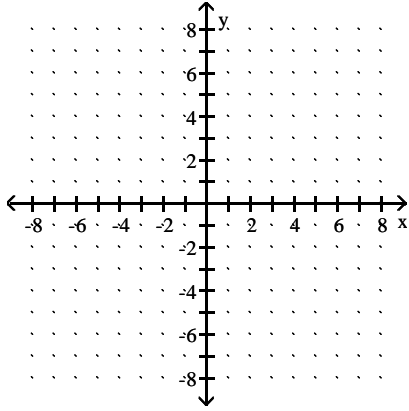

A) decreasing

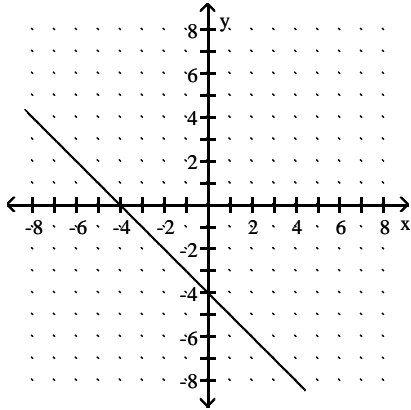

B) increasing

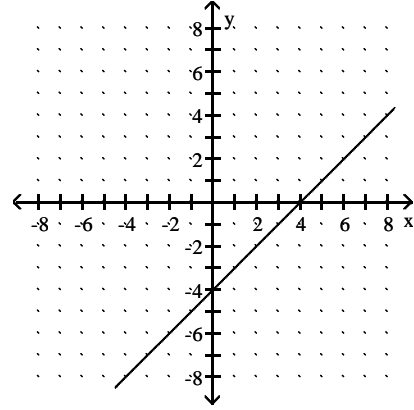

C) increasing

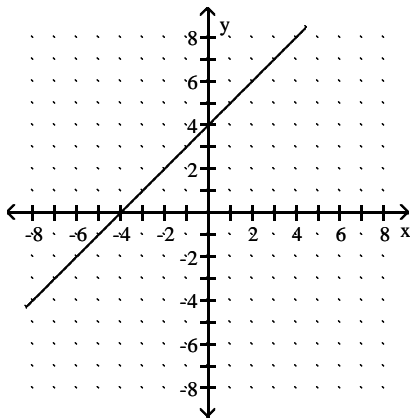

D) decreasing

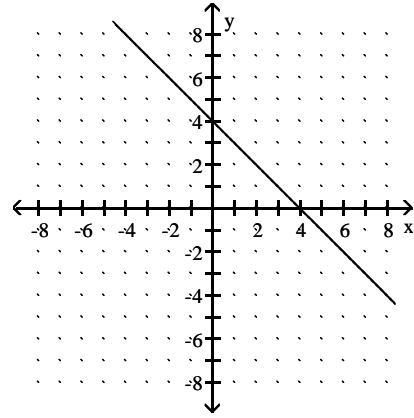

6)  $f(x) = \frac{3}{5}x - 1$

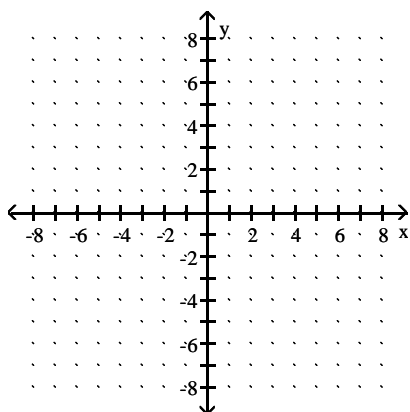

A) increasing

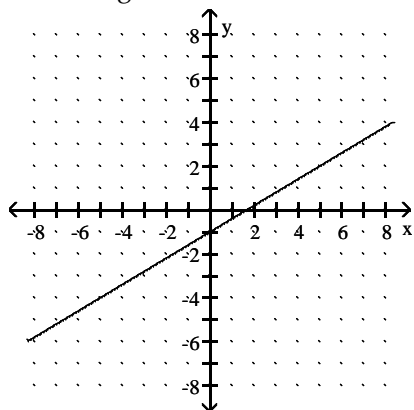

B) decreasing

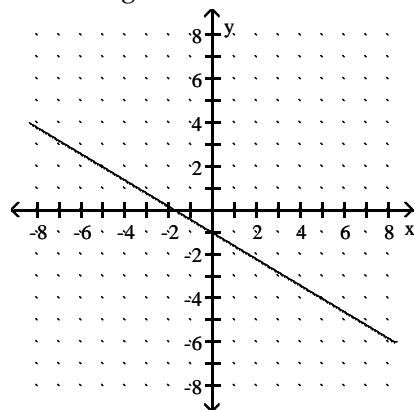

C) increasing

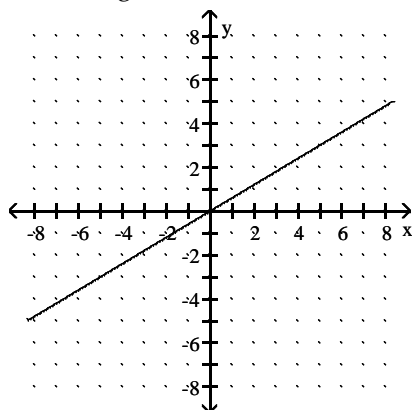

D) increasing

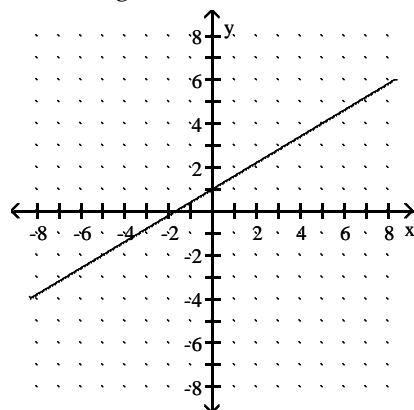



7)  $h(x) = -\frac{1}{2}x - 1$

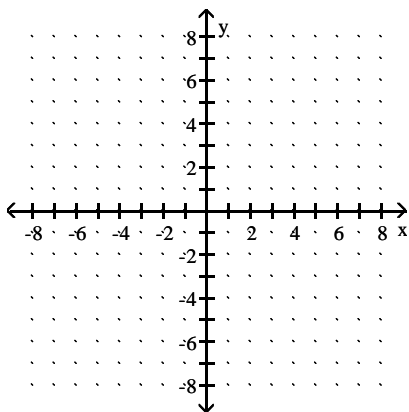

A) decreasing

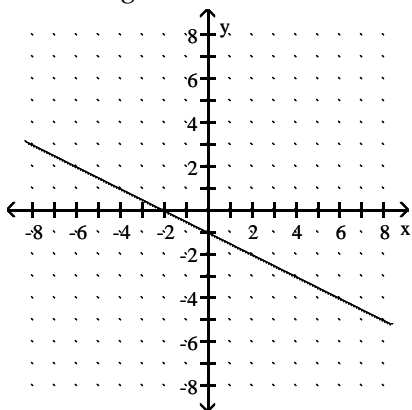

B) increasing

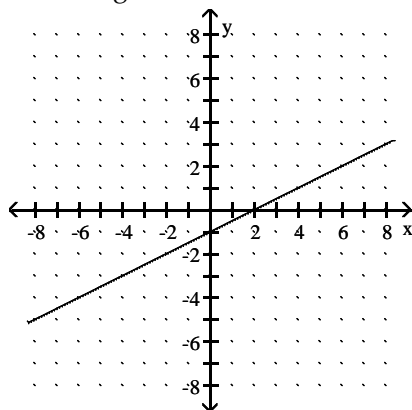

C) decreasing

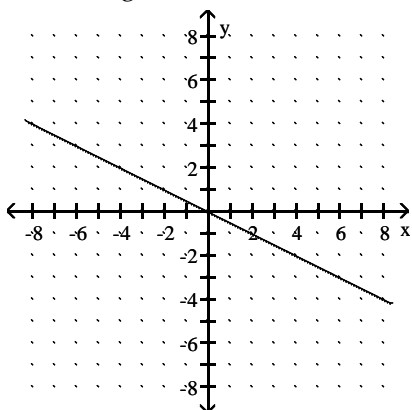

D) decreasing

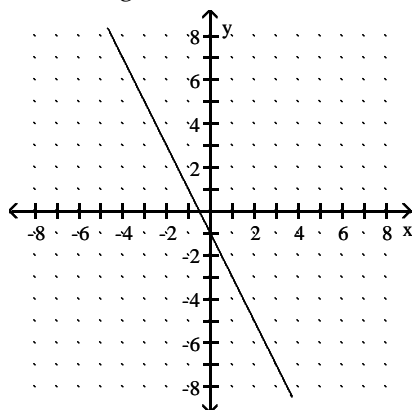

8)  $F(x) = 2$

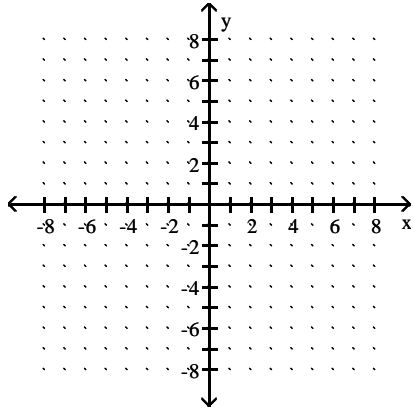

A) constant

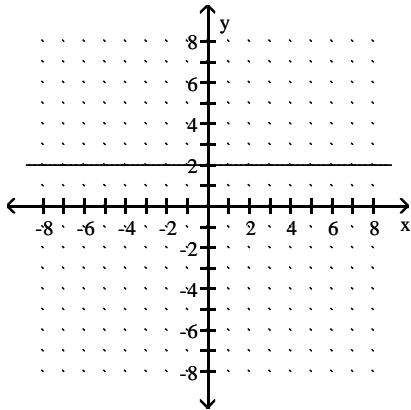

B) constant

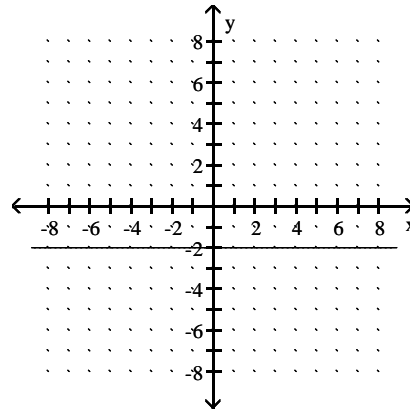

C) constant

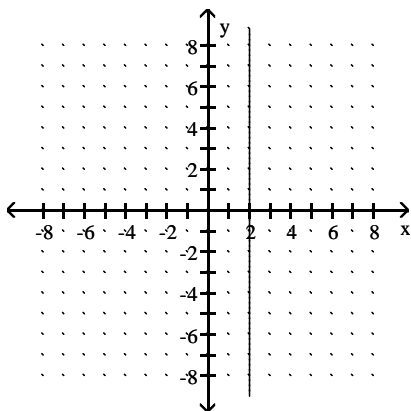

D) decreasing

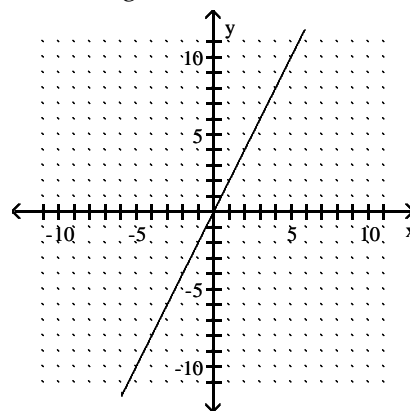

#### 4 Find the Zero of a Linear Function

**MULTIPLE CHOICE.** Choose the one alternative that best completes the statement or answers the question.

Find the zero of the linear function.

1)  $f(x) = x + 5$

A) -5

B) 5

C) 0

D) 10

2)  $g(x) = -x + 5$

A) 5

B) -5

C) 0

D) -10

3)  $h(x) = 14 - x$

A) 14

B) -14

C) 1

D) -28

4)  $f(x) = 9x + 18$

A) -2

B) 2

C) 0

D) 18

5)  $g(x) = 7x - 28$

A) 4

B) -4

C) 0

D) -28

6)  $h(x) = -3x + 4$

A)  $\frac{4}{3}$

B)  $-\frac{3}{4}$

C) 1

D) -1

7)  $F(x) = \frac{1}{6}x - 5$

A) 30

B)  $\frac{5}{6}$

C)  $-\frac{5}{6}$

D) -30

8)  $G(x) = -\frac{1}{6}x - 7$

A) -42

B)  $\frac{7}{6}$

C)  $-\frac{7}{6}$

D) 42

**Solve the problem.**

9) Suppose that  $f(x) = -x - 4$  and  $g(x) = x - 19$ .

(a) Solve  $f(x) = 0$ .

(b) Solve  $g(x) = 0$ .

(c) Solve  $f(x) = g(x)$ .

A) (a)  $x = -4$ ; (b)  $x = 19$ ; (c)  $x = 7.5$

C) (a)  $x = 4$ ; (b)  $x = 19$ ; (c)  $x = 7.5$

B) (a)  $x = -4$ ; (b)  $x = 19$ ; (c)  $x = -11.5$

D) (a)  $x = -4$ ; (b)  $x = -19$ ; (c)  $x = 7.5$

10) Suppose that  $f(x) = -x - 2$  and  $g(x) = x - 14$ .

(a) Solve  $f(x) > 0$ .

(b) Solve  $g(x) > 0$ .

(c) Solve  $f(x) \leq g(x)$ .

A) (a)  $x < -2$ ; (b)  $x > 14$ ; (c)  $x \geq 6$

C) (a)  $x > 2$ ; (b)  $x > 14$ ; (c)  $x > 6$

B) (a)  $x < -2$ ; (b)  $x < 14$ ; (c)  $x \geq -8$

D) (a)  $x < -2$ ; (b)  $x < -14$ ; (c)  $x \leq 6$

11) Let  $f(x)$  be the function represented by the dashed line and  $g(x)$  be the function represented by the solid line. Solve the equation  $f(x) = g(x)$ .

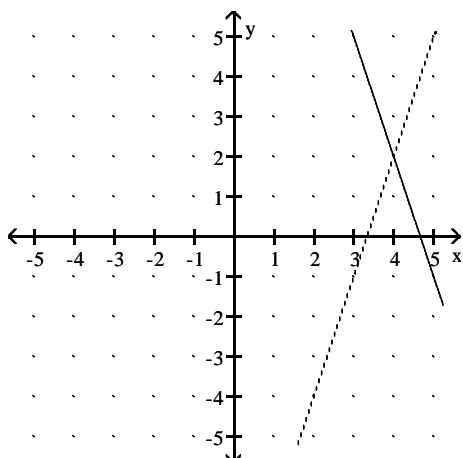

A)  $x = 4$

B)  $x = 2$

C)  $x = -4$

D)  $x = -2$

- 12) Let  $f(x)$  be the function represented by the dashed line and  $g(x)$  be the function represented by the solid line. Solve the equation  $f(x) < g(x)$ .

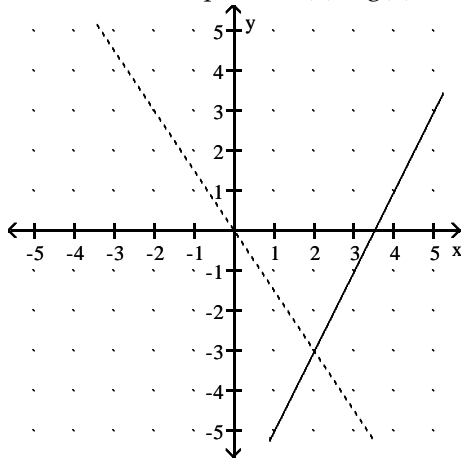

- A)  $x > 2$                       B)  $x < 2$                       C)  $x > -3$                       D)  $x < -3$

- 13) Let  $f(x)$  be the function represented by the dashed line and  $g(x)$  be the function represented by the solid line. Solve the equation  $f(x) \geq g(x)$ .

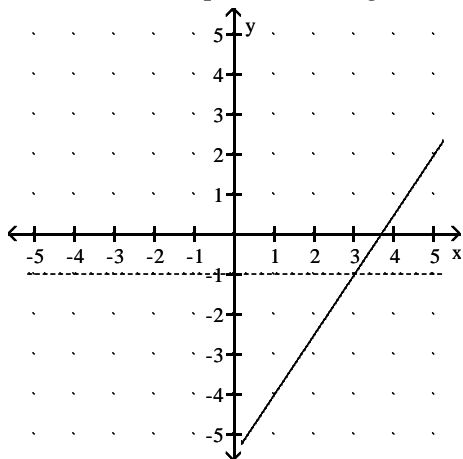

- A)  $x \leq 3$                       B)  $x \geq 3$                       C)  $x \geq -1$                       D)  $x < -1$

## 5 Build Linear Models from Verbal Descriptions

**MULTIPLE CHOICE.** Choose the one alternative that best completes the statement or answers the question.

**Solve the problem.**

- A truck rental company rents a moving truck one day by charging \$35 plus \$0.11 per mile. Write a linear equation that relates the cost  $C$ , in dollars, of renting the truck to the number  $x$  of miles driven. What is the cost of renting the truck if the truck is driven 160 miles?
 

A) $C(x) = 0.11x + 35$ ; \$52.60	B) $C(x) = 35x + 0.11$ ; \$5600.11
C) $C(x) = 0.11x + 35$ ; \$36.76	D) $C(x) = 0.11x - 35$ ; -\$17.40
- Linda needs to have her car towed. Little Town Auto charges a flat fee of \$85 plus \$2 per mile towed. Write a function expressing Linda's towing cost,  $c$ , in terms of miles towed,  $x$ . Find the cost of having a car towed 3 miles.
 

A) $c(x) = 2x + 85$ ; \$91	B) $c(x) = 2x$ ; \$6	C) $c(x) = 2x + 85$ ; \$81	D) $c(x) = 2x$ ; \$87
----------------------------	----------------------	----------------------------	-----------------------

- 3) To convert a temperature from degrees Celsius to degrees Fahrenheit, you multiply the temperature in degrees Celsius by 1.8 and then add 32 to the result. Express  $F$  as a linear function of  $c$ .
- A)  $F(c) = 1.8c + 32$       B)  $F(c) = 1.8 + 32c$       C)  $F(c) = 33.8c$       D)  $F(c) = \frac{c - 32}{1.8}$
- 4) If an object is dropped off of a tower, the velocity,  $V$ , of the object after  $t$  seconds can be obtained by multiplying  $t$  by 32 and adding 10 to the result. Express  $V$  as a linear function of  $t$ .
- A)  $V(t) = 32t + 10$       B)  $V(t) = 32 + 10t$       C)  $V(t) = 42t$       D)  $V(t) = \frac{t - 10}{32}$
- 5) If an object is dropped from a tower, then the velocity,  $V$  (in feet per second), of the object after  $t$  seconds can be obtained by multiplying  $t$  by 32 and adding 10 to the result. Find  $V$  as a linear function of  $t$ , and use this function to evaluate  $V(1.8)$ , the velocity of the object at time  $t = 1.8$  seconds.
- A)  $V(1.8) = 67.6$  feet per second      B)  $V(1.8) = 68.9$  feet per second  
 C)  $V(1.8) = 66.9$  feet per second      D)  $V(1.8) = 65.6$  feet per second
- 6) The cost for labor associated with fixing a washing machine is computed as follows: There is a fixed charge of \$35 for the repairman to come to the house, to which a charge of \$26 per hour is added. Find an equation that can be used to determine the labor cost,  $C(x)$ , of a repair that takes  $x$  hours.
- A)  $C(x) = 35 + 26x$       B)  $C(x) = 26 + 35x$       C)  $C(x) = (35 + 26)x$       D)  $C(x) = 35 - 26x$
- 7) In a certain city, the cost of a taxi ride is computed as follows: There is a fixed charge of \$2.75 as soon as you get in the taxi, to which a charge of \$1.85 per mile is added. Find an equation that can be used to determine the cost,  $C(x)$ , of an  $x$ -mile taxi ride.
- A)  $C(x) = 2.75 + 1.85x$       B)  $C(x) = 1.85 + 2.75x$       C)  $C(x) = 4.60x$       D)  $C(x) = 3.10x$
- 8) In a certain city, the cost of a taxi ride is computed as follows: There is a fixed charge of \$2.20 as soon as you get in the taxi, to which a charge of \$2.05 per mile is added. Find an equation that can be used to determine the cost,  $C(x)$ , of an  $x$ -mile taxi ride, and use this equation to find the cost of a 3-mile taxi ride.
- A) \$8.35      B) \$8.53      C) \$8.23      D) \$9.25
- 9) Marty's Tee Shirt & Jacket Company is to produce a new line of jackets with an embroidery of a Great Pyrenees dog on the front. There are fixed costs of \$600 to set up for production, and variable costs of \$41 per jacket. Write an equation that can be used to determine the total cost,  $C(x)$ , encountered by Marty's Company in producing  $x$  jackets.
- A)  $C(x) = 600 + 41x$       B)  $C(x) = 600x + 41$       C)  $C(x) = (600 + 41)x$       D)  $C(x) = 600 - 41x$
- 10) Marty's Tee Shirt & Jacket Company is to produce a new line of jackets with a embroidery of a Great Pyrenees dog on the front. There are fixed costs of \$690 to set up for production, and variable costs of \$40 per jacket. Write an equation that can be used to determine the total cost,  $C(x)$ , encountered by Marty's Company in producing  $x$  jackets, and use the equation to find the total cost of producing 72 jackets.
- A) \$3570      B) \$3582      C) \$3550      D) \$3562
- 11) Suppose that the quantity supplied  $S$  and quantity demanded  $D$  of baseball caps at a major league game are given by the functions  $S(p) = 5000 - 90p$  and  $D(p) = 110p$ , where  $p$  is the price. Find the equilibrium price for caps at the game. Then find the equilibrium quantity.
- A) \$25, \$2750      B) \$20, \$3200      C) \$45, \$950      D) \$20, \$2750

- 12) Regrind, Inc. regrinds used typewriter platens. The variable cost per platen is \$1.60. The total cost to regrind 110 platens is \$300. Find the linear cost function to regrind platens. If reground platens sell for \$9.50 each, how many must be reground and sold to break even?
- A)  $C(x) = 1.60x + 124$ ; 16 platens  
B)  $C(x) = 1.60x + 300$ ; 38 platens  
C)  $C(x) = 1.60x + 300$ ; 27 platens  
D)  $C(x) = 1.60x + 124$ ; 12 platens
- 13) Northwest Molded molds plastic handles which cost \$0.70 per handle to mold. The fixed cost to run the molding machine is \$7131 per week. If the company sells the handles for \$3.70 each, how many handles must be molded and sold weekly to break even?
- A) 2377 handles  
B) 1584 handles  
C) 10,187 handles  
D) 1620 handles
- 14) A lumber yard has fixed costs of \$5980.60 per day and variable costs of \$0.61 per board-foot produced. Lumber sells for \$2.31 per board-foot. How many board-feet must be produced and sold daily to break even?
- A) 3518 board-feet  
B) 2345 board-feet  
C) 9804 board-feet  
D) 2048 board-feet

## 2.2 Building Linear Models from Data

### 1 Draw and Interpret Scatter Diagrams

**MULTIPLE CHOICE.** Choose the one alternative that best completes the statement or answers the question.

Plot a scatter diagram.

1) x	12	-13	7	-7	-3	15	9	18	-2	1
y	65	29	40	-8	-2	31	7	62	4	2

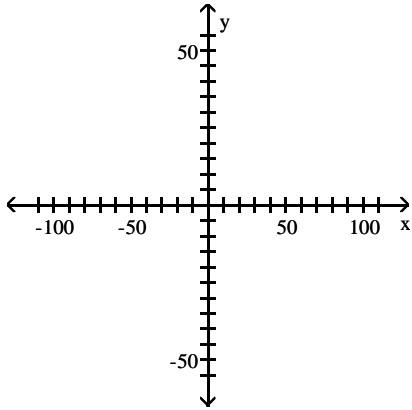

A)

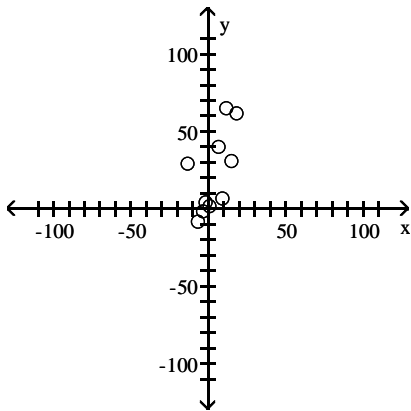

B)

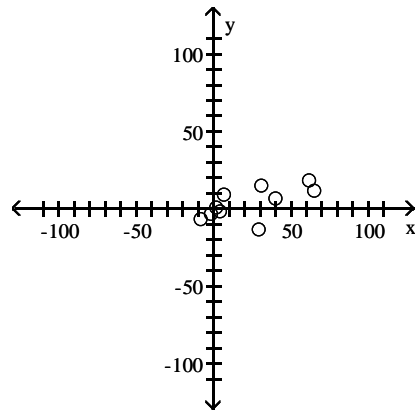

C)

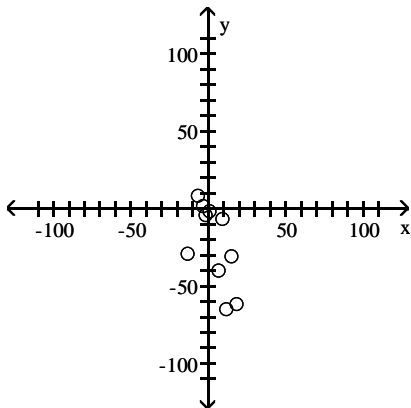

D)

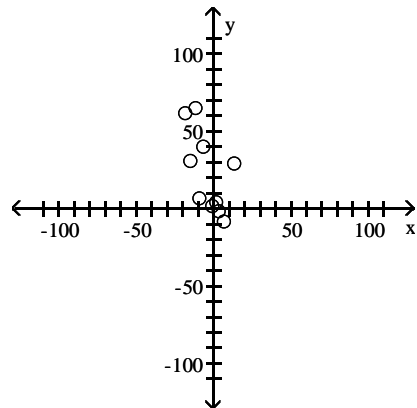

2)

x	19	30	30	45	60	67	74	86	87
y	14	32	36	44	70	52	66	98	77

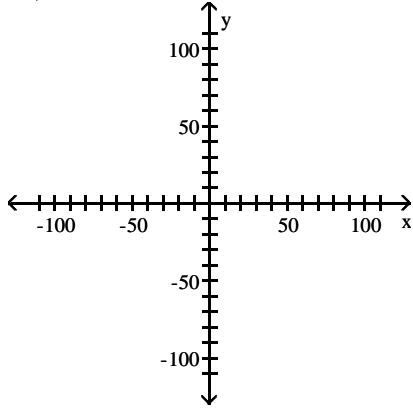

A)

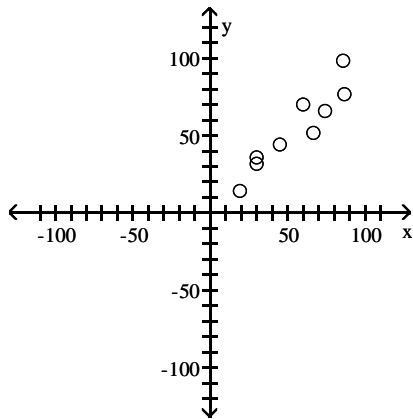

B)

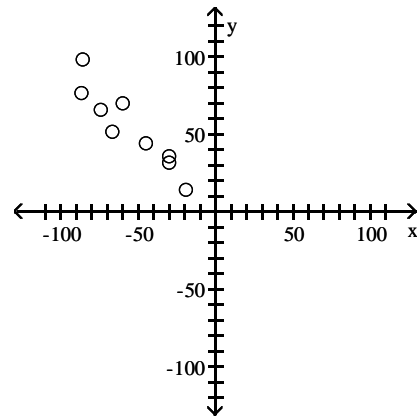

C)

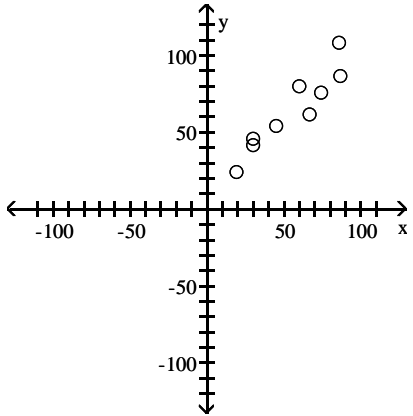

D)

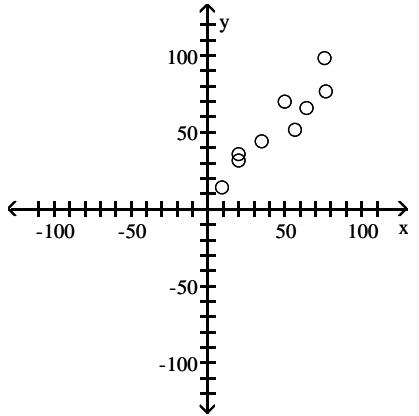

**Plot and interpret the appropriate scatter diagram.**

3) The table gives the times spent watching TV and the grades of several students.

Weekly TV (h)	6	12	18	24	30	36
Grade (%)	92.5	87.5	72.5	77.5	62.5	57.5

Which scatter diagram describes the data and the relationship, if any?



A)

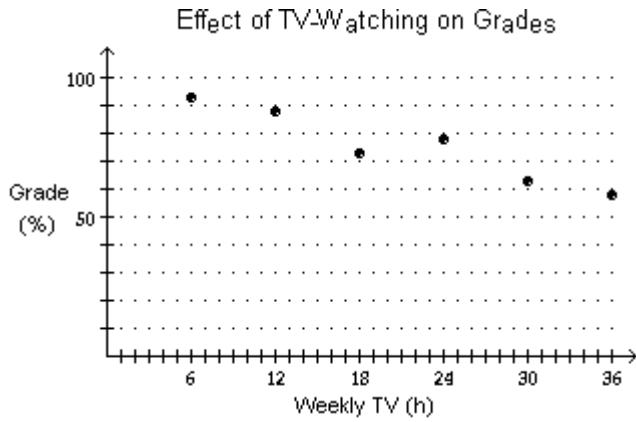

More hours spent watching TV may reduce grades.

B)

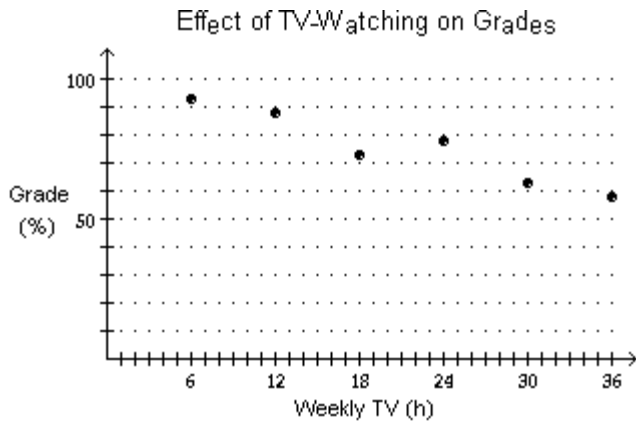

More hours spent watching TV may increase grades.

C)

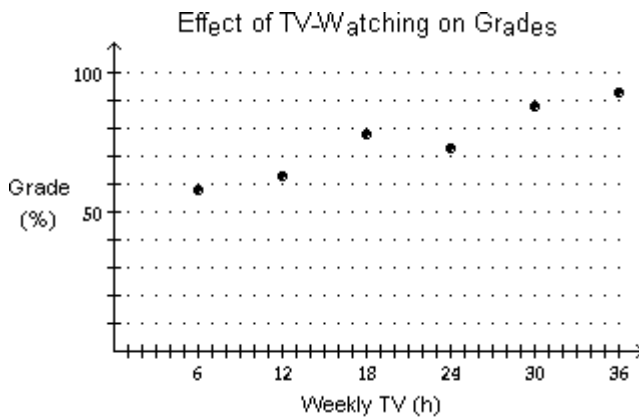

More hours spent watching TV may reduce grades.

D) none of these

**SHORT ANSWER. Write the word or phrase that best completes each statement or answers the question.**

- 4) The table shows the study times and test scores for a number of students. Draw a scatter plot of score versus time treating time as the independent variable.

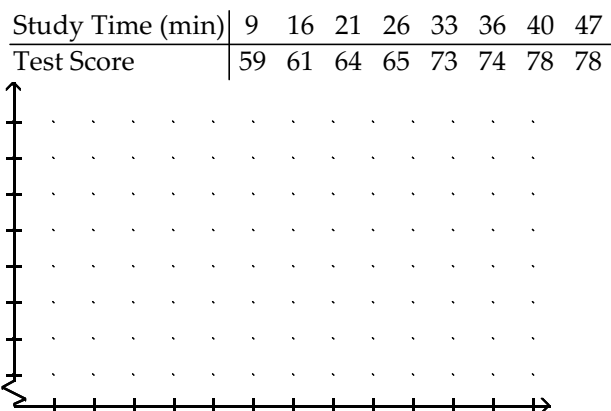

- 5) The one-day temperatures for 12 world cities along with their latitudes are shown in the table below. Make a scatter diagram for the data. Describe what happens to the one-day temperatures as the latitude increases.

City	Temperature (F)	Latitude
Oslo, Norway	30°	59°
Seattle, WA	57°	47°
Anchorage, AK	40°	61°
Paris, France	61°	48°
Vancouver, Canada	54°	49°
London, England	48°	51°
Tokyo, Japan	55°	35°
Cairo, Egypt	82°	30°
Mexico City, Mexico	84°	19°
Miami, FL	81°	25°
New Delhi, India	95°	28°
Manila, Philippines	93°	14°

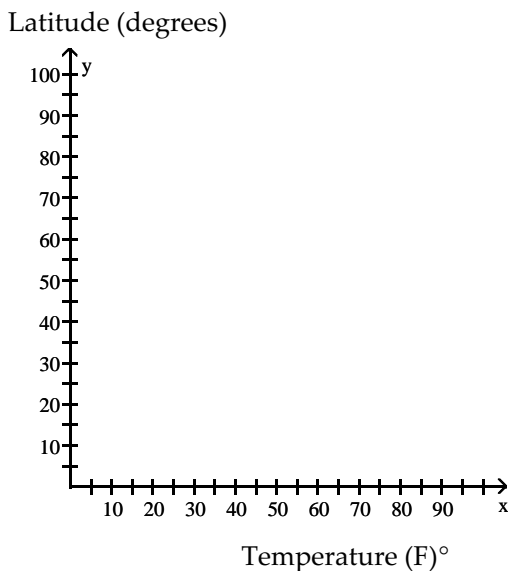

**MULTIPLE CHOICE. Choose the one alternative that best completes the statement or answers the question.**

**Solve the problem.**

6) The following scatter diagram shows heights (in inches) of children and their ages.



What happens to height as age increases?

A) Height increases as age increases.

B) Height decreases as age increases.

C) Height stays the same as age increases.

D) Height and age do not appear to be related.

7) The following scatter diagram shows heights (in inches) of children and their ages.

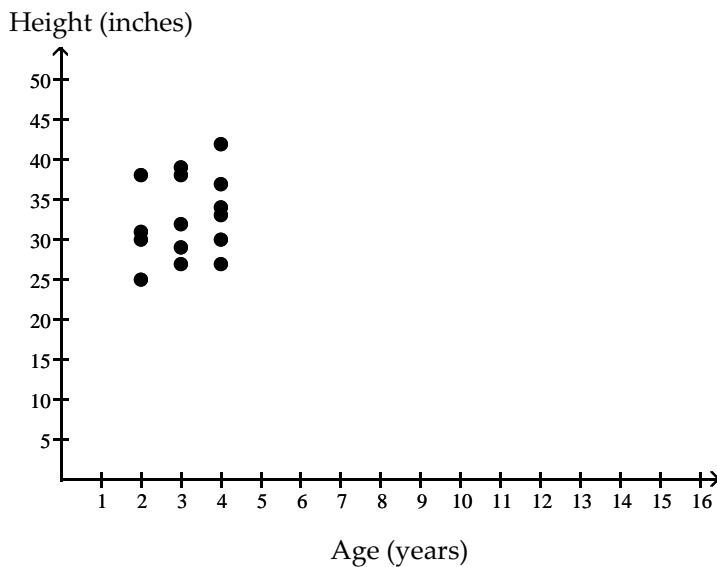

What is the expected height range for a 2-year old child?

A) 25–38 inches

B) 20–30 inches

C) 40–50 inches

D) 35–45 inches

8) The following scatter diagram shows heights (in inches) of children and their ages.

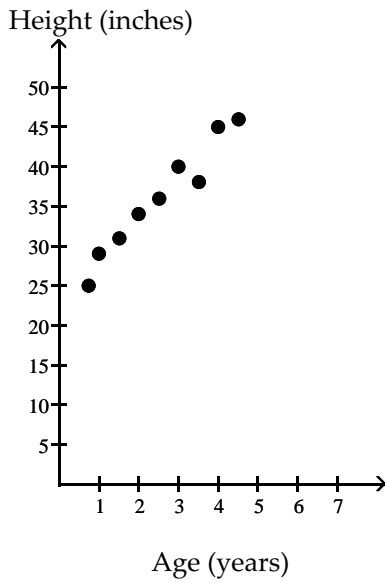

Based on this data, how old do you think a child is who is about 39 inches tall?

- A) 3 years                      B) 3 months                      C) 1 year                      D) 7 years

**2 Distinguish between Linear and Nonlinear Relations**

**MULTIPLE CHOICE. Choose the one alternative that best completes the statement or answers the question.**

**Determine if the type of relation is linear, nonlinear, or none.**

1)

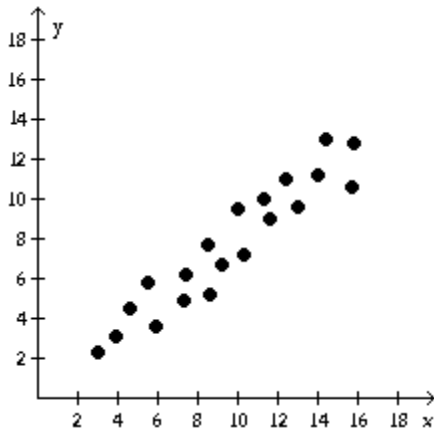

- A) linear                                      B) nonlinear                                      C) none

2)

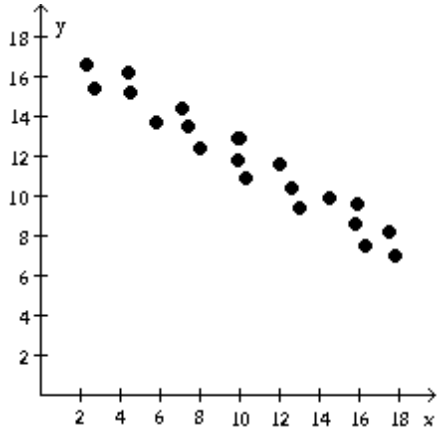

A) linear

B) nonlinear

C) none

3)

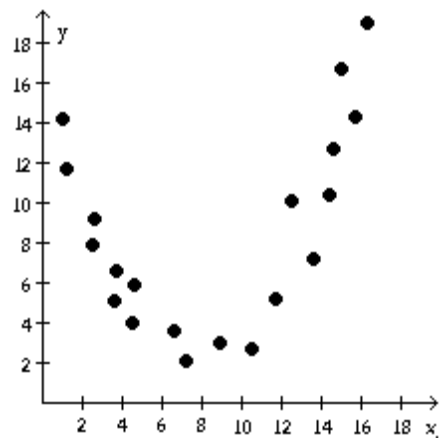

A) nonlinear

B) linear

C) none

4)

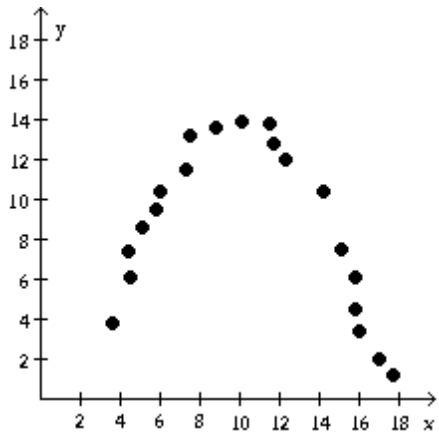

A) nonlinear

B) linear

C) none

5)

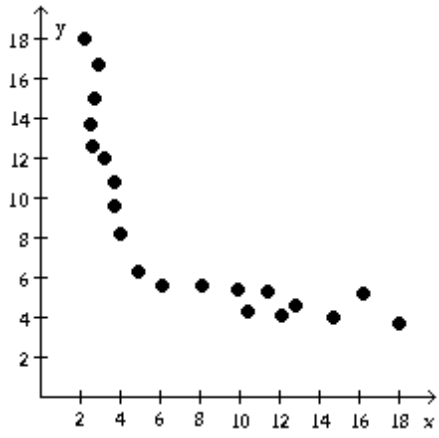

A) nonlinear

B) linear

C) none

6)

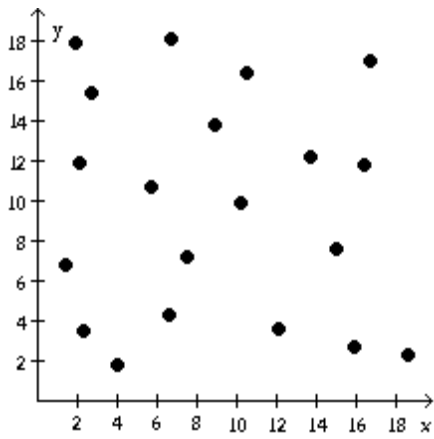

A) none

B) linear

C) nonlinear

**Solve the problem.**

7) Identify the scatter diagram of the relation that appears linear.

A)

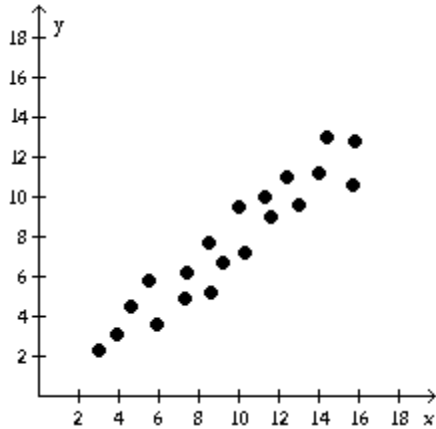

B)

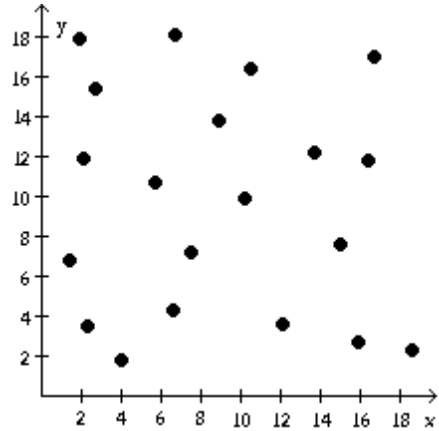

C)

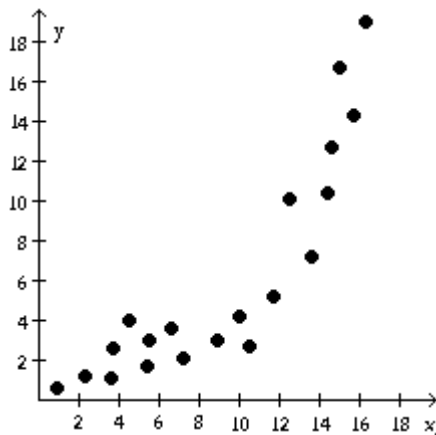

D)

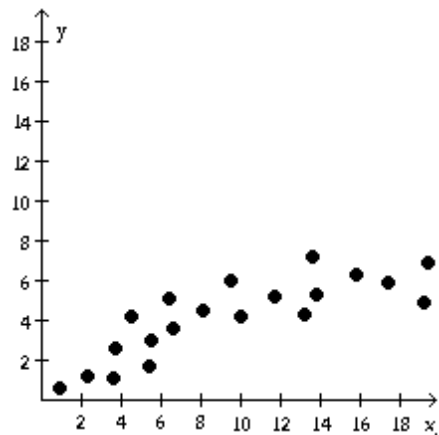

**3 Use a Graphing Utility to Find the Line of Best Fit**

**MULTIPLE CHOICE.** Choose the one alternative that best completes the statement or answers the question.

Use a graphing utility to find the equation of the line of best fit. Round to two decimal places, if necessary.

1) 
$$\begin{array}{c|cccc} x & 2 & 4 & 5 & 6 \\ \hline y & 7 & 11 & 13 & 20 \end{array}$$

A)  $y = 3x$

B)  $y = 2.8x + 0.15$

C)  $y = 2.8x$

D)  $y = 3x + 0.15$

2) 
$$\begin{array}{c|cccc} x & 6 & 8 & 20 & 28 & 36 \\ \hline y & 2 & 4 & 13 & 20 & 30 \end{array}$$

A)  $y = 0.90x - 3.79$

B)  $y = 0.95x - 2.79$

C)  $y = 0.80x - 3.79$

D)  $y = 0.85x - 2.79$

3) 
$$\begin{array}{c|ccccc} x & 1 & 3 & 5 & 7 & 9 \\ \hline y & 143 & 116 & 100 & 98 & 90 \end{array}$$

A)  $y = -6.2x + 140.4$

B)  $y = 6.2x - 140.4$

C)  $y = -6.8x + 150.7$

D)  $y = 6.8x - 150.7$

4) 
$$\begin{array}{c|cccccc} x & 1 & 2 & 3 & 4 & 5 & 6 \\ \hline y & 17 & 20 & 19 & 22 & 21 & 24 \end{array}$$

A)  $y = 1.17x + 16.4$

B)  $y = 1.03x + 18.9$

C)  $y = 1.17x + 18.9$

D)  $y = 1.03x + 16.4$

$$5) \begin{array}{c|c} x & 0 & 3 & 4 & 5 & 12 \\ \hline y & 8 & 2 & 6 & 9 & 12 \end{array}$$

A)  $y = 0.53x + 4.88$

B)  $y = 0.43x + 4.98$

C)  $y = 0.63x + 4.88$

D)  $y = 0.73x + 4.98$

$$6) \begin{array}{c|c} x & 3 & 5 & 7 & 15 & 16 \\ \hline y & 8 & 11 & 7 & 14 & 20 \end{array}$$

A)  $y = 0.75x + 5.07$

B)  $y = 0.75x + 4.07$

C)  $y = 0.85x + 3.07$

D)  $y = 0.95x + 3.07$

$$7) \begin{array}{c|c} x & 24 & 26 & 28 & 30 & 32 \\ \hline y & 15 & 13 & 20 & 16 & 24 \end{array}$$

A)  $y = 1.05x - 11.8$

B)  $y = 1.05x + 11.8$

C)  $y = 0.95x - 11.8$

D)  $y = 0.95x + 11.8$

$$8) \begin{array}{c|c} x & 2 & 4 & 6 & 8 & 10 \\ \hline y & 15 & 37 & 60 & 75 & 94 \end{array}$$

A)  $y = 9.8x - 2.6$

B)  $y = 10x - 3$

C)  $y = 9.2x - 2.1$

D)  $y = 9x - 3$

$$9) \begin{array}{c|c} x & 1.2 & 1.4 & 1.6 & 1.8 & 2.0 \\ \hline y & 54 & 53 & 55 & 54 & 56 \end{array}$$

A)  $y = 2.5x + 50.4$

B)  $y = 54$

C)  $y = 3x + 50$

D)  $y = 55.3$

$$10) \begin{array}{c|c} x & 10 & 20 & 30 & 40 & 50 \\ \hline y & 3.9 & 4.6 & 5.4 & 6.9 & 8.3 \end{array}$$

A)  $y = 0.11x + 2.49$

B)  $y = x - 8$

C)  $y = 0.5x - 2$

D)  $y = 0.17x + 2.11$

$$11) \begin{array}{c|c} x & 2 & 3 & 7 & 8 & 10 \\ \hline y & 3 & 4 & 4 & 5 & 6 \end{array}$$

A)  $y = 0.30x + 4.29$

B)  $y = 0.30x + 2.57$

C)  $y = 0.32x + 4.29$

D)  $y = 0.32x + 2.57$

$$12) \begin{array}{c|c} x & 2 & 3 & 7 & 8 & 10 \\ \hline y & 2 & 4 & 4 & 6 & 6 \end{array}$$

A)  $y = 0.43x + 1.79$

B)  $y = 1.79x - 1.86$

C)  $y = 1.79x + 0.43$

D)  $y = -1.86x + 1.79$

13) Ten students in a graduate program were randomly selected. Their grade point averages (GPAs) when they entered the program were between 3.5 and 4.0. The following data were obtained regarding their GPAs on entering the program versus their current GPAs.

Entering GPA	Current GPA
3.5	3.6
3.8	3.7
3.6	3.9
3.6	3.6
3.5	3.9
3.9	3.8
4.0	3.7
3.9	3.9
3.5	3.8
3.7	4.0

A)  $y = 0.03x + 3.67$

B)  $y = 0.02x + 4.91$

C)  $y = 0.50x + 5.81$

D)  $y = 0.33x + 2.51$



- 14) Two different tests are designed to measure employee productivity and dexterity. Several employees are randomly selected and tested with these results.

Productivity	23	25	28	21	21	25	26	30	34	36
Dexterity	49	53	59	42	47	53	55	63	67	75

- A)  $y = 5.05 + 1.91x$       B)  $y = 2.36 + 2.03x$       C)  $y = 10.7 + 1.53x$       D)  $y = 75.3 - 0.329x$

- 15) Managers rate employees according to job performance and attitude. The results for several randomly selected employees are given below.

Performance	59	63	65	69	58	77	76	69	70	64
Attitude	72	67	78	82	75	87	92	83	87	78

- A)  $y = 11.7 + 1.02x$       B)  $y = 2.81 + 1.35x$       C)  $y = -47.3 + 2.02x$       D)  $y = 92.3 - 0.669x$

**SHORT ANSWER. Write the word or phrase that best completes each statement or answers the question.**

**Solve the problem.**

- 16) The one-day temperatures for 12 world cities along with their latitudes are shown in the table below. Make a scatter diagram for the data. Then find the line of best fit and graph it on the scatter diagram.

City	Temperature (F)	Latitude
Oslo, Norway	30°	59°
Seattle, WA	57°	47°
Anchorage, AK	40°	61°
Paris, France	61°	48°
Vancouver, Canada	54°	49°
London, England	48°	51°
Tokyo, Japan	55°	35°
Cairo, Egypt	82°	30°
Mexico City, Mexico	84°	19°
Miami, FL	81°	25°
New Delhi, India	95°	28°
Manila, Philippines	93°	14°

Latitude (degrees)

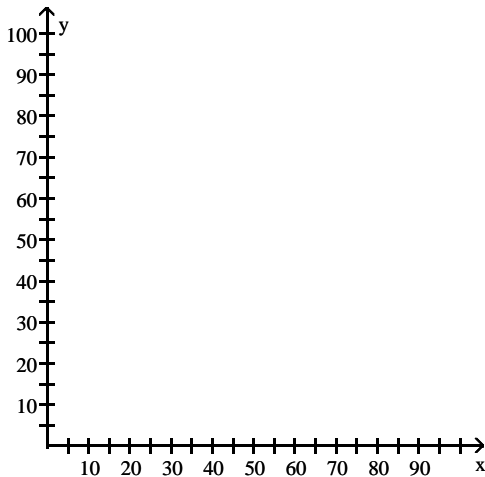

Temperature (F)°

**MULTIPLE CHOICE. Choose the one alternative that best completes the statement or answers the question.**

- 17) A drug company establishes that the most effective dose of a new drug relates to body weight as shown below. Let body weight be the independent variable and drug dosage be the dependent variable. Use a graphing utility to draw a scatter diagram and to find the line of best fit. What is the most effective dosage for a person weighing 130 lbs?

Body Weight (lbs)	Drug Dosage (mg)
50	8
100	10
150	16
200	20
250	23

- A) 13.8 mg                      B) 22.47 mg                      C) 13 mg                      D) 10.07 mg
- 18) A marina owner wishes to estimate a linear function that relates boat length in feet and its draft (depth of boat below water line) in feet. He collects the following data. Let boat length represent the independent variable and draft represent the dependent variable. Use a graphing utility to draw a scatter diagram and to find the line of best fit. What is the draft for a boat 60 ft in length (to the nearest tenth)?

Boat Length (ft)	Draft (ft)
25	2.5
25	2
30	3
30	3.5
45	6
45	7
50	7
50	8

- A) 9.7                      B) 15.7                      C) 10.5                      D) 10.3
- 19) A survey of the interest rates earned by Certificates of Deposit (CDs) showed the following percents for the length of time (in years) for holding the CD. Let length of time represent the independent variable and interest rate represent the dependent variable. Use a graphing utility to draw a scatter diagram and to find the line of best fit. What is the estimate of the interest rate for a CD held for 30 years (to the nearest thousandth)?

CD Maturity (yrs)	Interest rate (%)
5	8.458
10	8.470
15	8.496
20	8.580
25	8.625

- A) 8.669                      B) 8.675                      C) 9.064                      D) 8.874

- 20) Super Sally, a truly amazing individual, picks up a rock and throws it as hard as she can. The table below displays the relationship between the rock's horizontal distance,  $d$  (in feet) from Sally and the initial speed with which she throws.

Initial speed( in ft/sec), $v$	10	15	20	25	30
Horizontal distance of the rock (in feet), $d$	9.9	14.8	19.1	24.5	28.2

Assume that the horizontal distance travelled varies linearly with the speed with which the rock is thrown. Using a graphing utility, find the line of best fit, and estimate, rounded to two decimal places, the horizontal distance of the rock if the initial speed is 33 ft/sec.

- A) 31.34 feet                      B) 26.67 feet                      C) 34.76 feet                      D) 31.33 feet

**SHORT ANSWER. Write the word or phrase that best completes each statement or answers the question.**

- 21) The following data represents the amount of money Tom is saving each month since he graduated from college.

month	1	2	3	4	5	6	7
savings	\$52	\$70	\$81	\$91	\$102	\$118	\$132

Using the line of best fit for the data set, predict the amount he will save in the 24th month after graduating from college.

- 22) The following data represents the amount of money Tom is saving each month since he graduated from college.

month	1	2	3	4	5	6	7
savings	\$52	\$70	\$81	\$91	\$102	\$118	\$132

Find the slope of the line of best fit for the data set and interpret it.

- 23) The following data represents the Olympic winning time in Women's 100 m Freestyle.

year	1972	1976	1980	1984	1988	1992	1996
time	58.59	55.65	54.79	55.92	54.93	54.65	54.50

Using the line of best fit (with slope correct to 5 decimal places) for the data set, predict the Olympic winning time in 2000.

- 24) The following data represents the Olympic winning time in Women's 100 m Freestyle.

year	1972	1976	1980	1984	1988	1992	1996
time	58.59	55.65	54.79	55.92	54.93	54.65	54.50

Find the slope of the line of best fit for the data set and interpret it.

- 25) The following data represents the number of employees at a company at the start of each year since the company began.

month	1	2	3	4	5	6	7
number	3	172	403	571	823	1061	1194

Using the line of best fit for the data set, predict the number of employees at the start of the 10th year.

- 26) The following data represents the number of employees at a company at the start of each year since the company began.

month	1	2	3	4	5	6	7
number	3	172	403	571	823	1061	1194

Find the slope of the line of best fit for the data set and interpret it.

## 2.3 Quadratic Functions and Their Zeros

### 1 Find the Zeros of a Quadratic Function by Factoring

**MULTIPLE CHOICE.** Choose the one alternative that best completes the statement or answers the question.

**Use factoring to find the zeros of the quadratic function. List the x-intercepts of the graph of the function.**

1)  $f(x) = x^2 + 5x - 36$

A)  $x = -9, x = 4$

B)  $x = 9, x = 4$

C)  $x = -9, x = 1$

D)  $x = 9, x = -4$

2)  $g(x) = x^2 - 7x + 10$

A)  $x = 5, x = 2$

B)  $x = -5, x = -2$

C)  $x = -5, x = 2$

D)  $x = 10, x = 0$

3)  $F(x) = x^2 - x - 30$

A)  $x = -5, x = 6$

B)  $x = 5, x = 6$

C)  $x = 1, x = 30$

D)  $x = -5, x = -6$

4)  $h(x) = x^2 + 8x - 33$

A)  $x = -11, x = 3$

B)  $x = 11, x = 3$

C)  $x = -11, x = 1$

D)  $x = 11, x = -3$

5)  $f(x) = x^2 - 8x - 48$

A)  $x = 12, x = -4$

B)  $x = 12, x = 4$

C)  $x = -12, x = 1$

D)  $x = -12, x = 4$

6)  $G(x) = x^2 - 3x$

A)  $x = 0, x = 3$

B)  $x = 0, x = -3$

C)  $x = 3$

D)  $x = -3$

7)  $f(x) = 4x^2 - 3x - 7$

A)  $x = \frac{7}{4}, x = -1$

B)  $x = \frac{4}{7}, x = -1$

C)  $x = \frac{4}{7}, x = 1$

D)  $x = \frac{4}{7}, x = 0$

8)  $g(x) = 121x^2 - 1$

A)  $x = \frac{1}{11}, x = -\frac{1}{11}$

B)  $x = \frac{1}{11}$

C)  $x = -\frac{1}{11}$

D)  $x = \frac{1}{11}, x = 0$

9)  $F(x) = 5x^2 + 10x - 15$

A)  $x = 1, x = -3$

B)  $x = 1, x = 3$

C)  $x = -1, x = -3$

D)  $x = -1, x = 3$

10)  $h(x) = 9x^2 - 27x$   
 A)  $x = 0, x = 3$                       B)  $x = 3$                       C)  $x = 9, x = 3$                       D)  $x = 0$

11)  $f(x) = x^2 - 25$   
 A)  $x = -5, x = 5$                       B)  $x = -625, x = 625$                       C)  $x = 5$                       D)  $x = -5$

## 2 Find the Zeros of a Quadratic Function Using the Square Root Method

**MULTIPLE CHOICE.** Choose the one alternative that best completes the statement or answers the question.

Find the zeros of the quadratic function using the Square Root Method. List the  $x$ -intercepts of the graph of the function.

1)  $f(x) = x^2 - 64$   
 A)  $x = -8, x = 8$                       B)  $x = -4096, x = 4096$   
 C)  $x = 8$                       D)  $x = -8$

2)  $F(x) = x^2 - 11$   
 A)  $x = \sqrt{11}, x = -\sqrt{11}$                       B)  $x = -11, x = 11$                       C)  $x = \sqrt{11}$                       D)  $x = 11$

3)  $g(x) = (x - 6)^2 - 25$   
 A)  $x = 1, x = 11$                       B)  $x = 31$                       C)  $x = -5, x = 5$                       D)  $x = -11, x = 1$

4)  $h(x) = (x + 7)^2 - 49$   
 A)  $x = -14, x = 0$                       B)  $x = 0$                       C)  $x = -7, x = 7$                       D)  $x = -14$

5)  $G(x) = (2x - 1)^2 - 49$   
 A)  $x = -3, x = 4$                       B)  $x = -4, x = 3$                       C)  $x = -6, x = 8$                       D)  $x = -8, x = 6$

## 3 Find the Zeros of a Quadratic Function by Completing the Square

**MULTIPLE CHOICE.** Choose the one alternative that best completes the statement or answers the question.

Find the zeros of the quadratic function by completing the square. List the  $x$ -intercepts of the graph of the function.

1)  $f(x) = x^2 + 4x - 32$   
 A)  $x = 4, x = -8$                       B)  $x = -4, x = 8$                       C)  $x = \sqrt{6}, x = -1$                       D)  $x = -24, x = -8$

2)  $g(x) = 3x^2 - 3x - 6$   
 A)  $x = 2, x = -1$                       B)  $x = \frac{1}{2}, x = -1$                       C)  $x = \frac{1}{2}, x = 1$                       D)  $x = \frac{1}{2}, x = 0$

3)  $F(x) = x^2 + 8x - 9$   
 A)  $x = 1, x = -9$                       B)  $x = -1, x = 9$                       C)  $x = \sqrt{-9}, x = \sqrt{9}$                       D)  $x = 0, x = -9$

4)  $f(x) = x^2 - \frac{10}{3}x + \frac{25}{9}$   
 A)  $x = \frac{5}{3}, x = \frac{5}{3}$                       B)  $x = -\frac{5}{3}, x = \frac{5}{3}$                       C)  $x = \frac{5}{3}, x = -\frac{5}{3}$                       D)  $x = -\frac{5}{3}, x = -\frac{5}{3}$

5)  $g(x) = 36x^2 + 36x + 5$   
 A)  $x = -\frac{1}{6}, x = -\frac{5}{6}$                       B)  $x = -\frac{1}{36}, x = -\frac{5}{36}$                       C)  $x = \frac{1}{6}, x = \frac{5}{6}$                       D)  $x = -\frac{5}{18}, x = \frac{5}{18}$

$$6) f(x) = 16x^2 + 48x + 27$$

$$A) x = -\frac{3}{4}, x = -\frac{9}{4}$$

$$B) x = -\frac{3}{16}, x = -\frac{9}{16}$$

$$C) x = \frac{3}{4}, x = \frac{9}{4}$$

$$D) x = -\frac{9}{4}, x = \frac{9}{4}$$

#### 4 Find the Zeros of a Quadratic Function Using the Quadratic Formula

**MULTIPLE CHOICE.** Choose the one alternative that best completes the statement or answers the question.

Find the real zeros, if any, of each quadratic function using the quadratic formula. List the x-intercepts, if any, of the graph of the function.

$$1) f(x) = 5x^2 - 7x - 6$$

$$A) x = -\frac{3}{5}, x = 2$$

$$B) x = \frac{3}{5}, x = -2$$

$$C) x = -3, x = 2$$

$$D) x = -\frac{6}{5}, x = 4$$

$$2) g(x) = x^2 - 19 - 3x$$

$$A) x = \frac{3 \pm \sqrt{85}}{2}$$

$$B) x = 3, x = 19$$

$$C) x = \frac{3 + \sqrt{85}}{2}$$

D) No real zeros or x-intercepts

$$3) G(x) = x^2 + 2x - 8$$

$$A) x = -4, x = 2$$

$$B) x = 4, x = 2$$

$$C) x = 4, x = -2$$

$$D) x = -4, x = -2$$

$$4) H(x) = 5x^2 - 34x - 7$$

$$A) x = -\frac{1}{5}, x = 7$$

$$B) x = -5, x = 7$$

$$C) x = -\frac{1}{7}, x = 5$$

$$D) x = -\frac{1}{7}, x = -5$$

$$5) F(x) = 5x^2 - 7x - 1$$

$$A) x = \frac{7 \pm \sqrt{69}}{10}$$

$$B) x = \frac{7 + \sqrt{69}}{10}$$

$$C) x = \frac{-7 \pm \sqrt{69}}{10}$$

D) No real zeros or x-intercepts

$$6) h(x) = x^2 - 6x + 45$$

$$A) x = -3, x = 6$$

$$B) x = 6, x = -12$$

$$C) x = 9, x = -3$$

D) No real zeros or x-intercepts

#### 5 Find the Point of Intersection of Two Functions

**MULTIPLE CHOICE.** Choose the one alternative that best completes the statement or answers the question.

Solve  $f(x) = g(x)$ . Find the points of intersection of the graphs of the two functions.

$$1) f(x) = 6x + 7$$

$$g(x) = x^2$$

$$A) x = -1, x = 7$$

$$B) x = 1, x = 7$$

$$C) x = -1, x = \frac{1}{7}$$

$$D) x = 1, x = -\frac{1}{7}$$

$$2) f(x) = x^2 - 12x + 27$$

$$g(x) = 2x^2 - 12x + 18$$

A)  $x = 3, x = -3$

B)  $x = \frac{1}{3}, x = -3$

C)  $x = -\frac{\sqrt{18}}{2}, x = \frac{\sqrt{18}}{2}$

D)  $x = -\frac{\sqrt{10}}{2}, x = \frac{\sqrt{10}}{2}$

$$3) f(x) = 9x^2$$

$$g(x) = -2x$$

A)  $x = -\frac{2}{9}, x = 0$

B)  $x = \pm \frac{2}{9}$

C)  $x = 0$

D)  $x = \frac{2}{9}, x = 0$

$$4) f(x) = x^2 + 6x + 13$$

$$g(x) = 29$$

A)  $x = -8, x = 2$

B)  $x = -2, x = 8$

C)  $x = \frac{6 \pm \sqrt{29}}{2}$

D) no real numbers

## 6 Solve Equations That Are Quadratic in Form

**MULTIPLE CHOICE.** Choose the one alternative that best completes the statement or answers the question.

**Find the real zeros of the function. List the x-intercepts of the graph of the function.**

$$1) f(x) = x^4 - 1296$$

A)  $x = -6, x = 6$

B)  $x = -36, x = 36$

C)  $x = -\sqrt{6}, x = \sqrt{6}$

D) no real solution

$$2) F(x) = x^4 - 50x^2 + 49$$

A)  $x = -1, x = 1, x = -7, x = 7$

B)  $x = -7, x = 7$

C)  $x = -49, x = 49$

D)  $x = -50, x = 50$

$$3) G(x) = x^4 + 2x^2 - 24$$

A)  $x = -2, x = 2$

B)  $x = -\sqrt{6}, x = \sqrt{6}$

C)  $x = -4, x = 6$

D) no real solution

$$4) h(x) = 2x^4 - 69x^2 - 108$$

A)  $x = -6, x = 6$

B)  $x = -\frac{\sqrt{6}}{2}, x = \frac{\sqrt{6}}{2}, x = -6, x = 6$

C)  $x = 6$

D) no real solution

$$5) H(x) = x^6 + 7x^3 - 8$$

A)  $x = -2, x = 1$

B)  $x = 8$

C)  $x = 2$

D)  $x = 2, x = -1$

$$6) f(x) = 2(x + 1)^2 + 12(x + 1) + 16$$

A)  $x = -3, x = -5$

B)  $x = \frac{3}{2}, x = 3$

C)  $x = -2, x = -5$

D)  $x = -\frac{3}{2}, x = -4$

$$7) P(x) = (2x - 7)^2 + 4(2x - 7) - 12$$

A)  $x = \frac{1}{2}, x = \frac{9}{2}$

B)  $x = -\frac{1}{2}, x = -\frac{9}{2}$

C)  $x = \frac{13}{2}, x = -\frac{5}{2}$

D)  $x = -\frac{13}{7}, x = \frac{5}{2}$

- 8)  $Q(x) = (-9x + 3)^2 + 6(-9x + 3) + 8$
- A)  $x = \frac{7}{9}, x = \frac{5}{9}$       B)  $x = -\frac{7}{9}, x = -\frac{5}{9}$       C)  $x = -4, x = -2$       D)  $x = \frac{1}{9}, x = -\frac{1}{9}$

**Solve the problem.**

- 9) The length of a vegetable garden is 4 feet longer than its width. If the area of the garden is 165 square feet, find its dimensions.
- A) 11 ft by 15 ft      B) 10 ft by 16 ft      C) 12 ft by 16 ft      D) 10 ft by 14 ft
- 10) An open box is to be constructed from a square sheet of plastic by removing a square of side 4 inches from each corner, and then turning up the sides. If the box must have a volume of 1600 cubic inches, find the length of one side of the open box.
- A) 20 in.      B) 24 in.      C) 28 in.      D) 19 in.
- 11) A ball is thrown vertically upward from the top of a building 112 feet tall with an initial velocity of 96 feet per second. The distance  $s$  (in feet) of the ball from the ground after  $t$  seconds is  $s = 112 + 96t - 16t^2$ . After how many seconds does the ball strike the ground?
- A) 7 sec      B) 113 sec      C) 6 sec      D) 9 sec
- 12) As part of a physics experiment, Ming drops a baseball from the top of a 305-foot building. To the nearest tenth of a second, for how many seconds will the baseball fall? (Hint: Use the formula  $h = 16t^2$ , which gives the distance  $h$ , in feet, that a free-falling object travels in  $t$  seconds.)
- A) 4.4 sec      B) 76.3 sec      C) 19.1 sec      D) 1.1 sec
- 13) If a polygon, of  $n$  sides has  $\frac{1}{2}n(n - 3)$  diagonals, how many sides will a polygon with 560 diagonals have?
- A) 35 sides      B) 36 sides      C) 34 sides      D) 37 sides

## 2.4 Properties of Quadratic Functions

### 1 Graph a Quadratic Function Using Transformations

**MULTIPLE CHOICE.** Choose the one alternative that best completes the statement or answers the question.

Match the graph to one of the listed functions.

1)

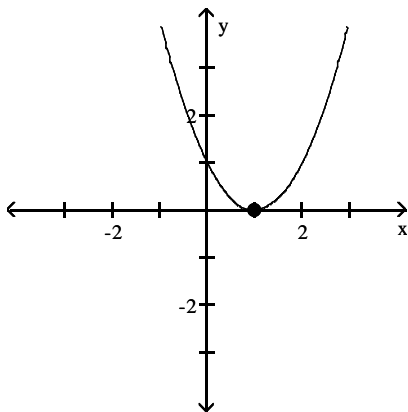

- A)  $f(x) = x^2 - 2x + 1$       B)  $f(x) = x^2 + 2x + 1$       C)  $f(x) = x^2 - 2x$       D)  $f(x) = x^2 + 2x$



2)

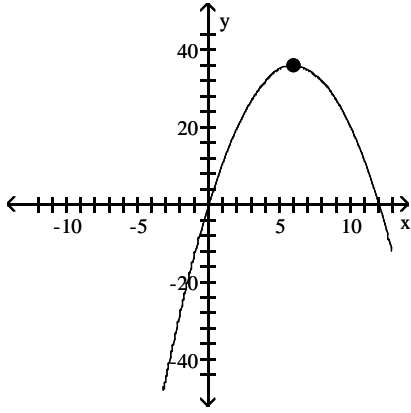

A)  $f(x) = -x^2 + 12x$

B)  $f(x) = x^2 + 12x$

C)  $f(x) = -x^2 + 12$

D)  $f(x) = x^2 + 12$

3)

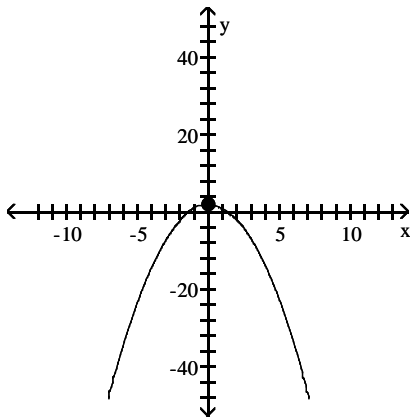

A)  $f(x) = -x^2 + 2$

B)  $f(x) = x^2 + 2x$

C)  $f(x) = -x^2 + 2x$

D)  $f(x) = x^2 + 2$

4)

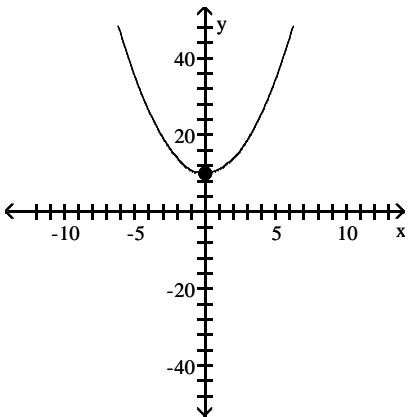

A)  $f(x) = x^2 + 10$

B)  $f(x) = x^2 + 10x$

C)  $f(x) = -x^2 + 10x$

D)  $f(x) = -x^2 + 10$

Graph the function  $f$  by starting with the graph of  $y = x^2$  and using transformations (shifting, compressing, stretching, and/or reflection).

5)  $f(x) = x^2 - 2$

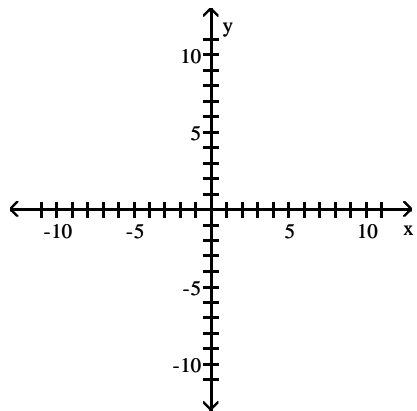

A)

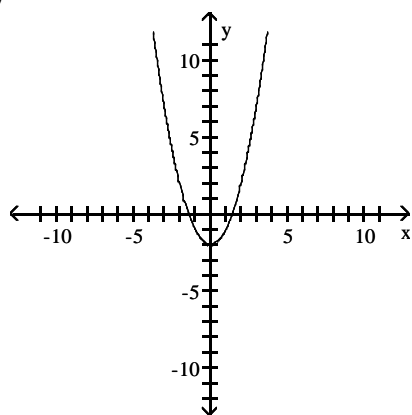

B)

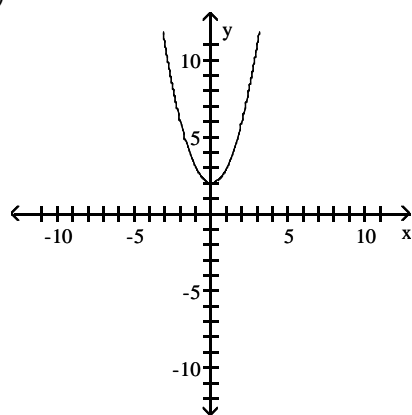

C)

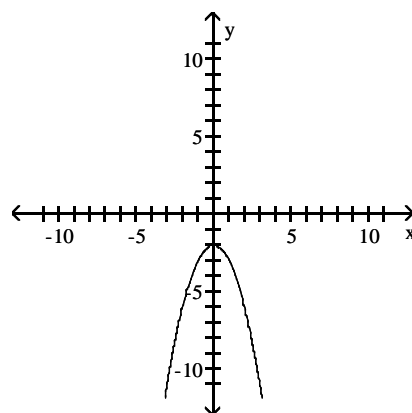

D)

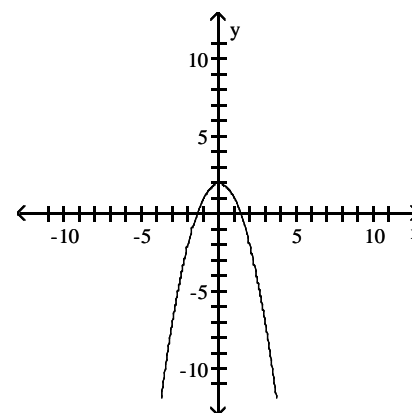

6)  $f(x) = -5x^2$

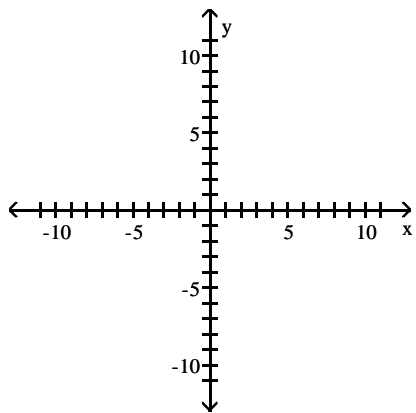

A)

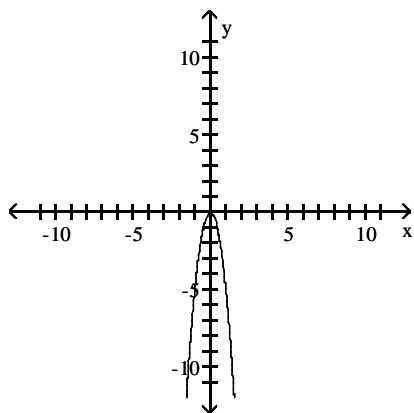

B)

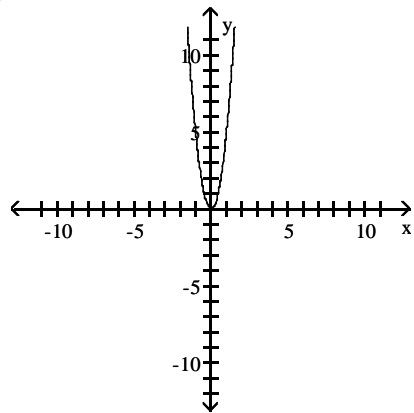

C)

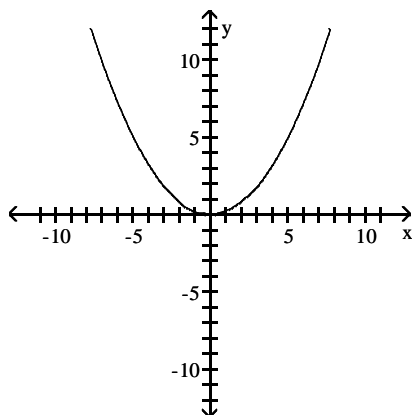

D)

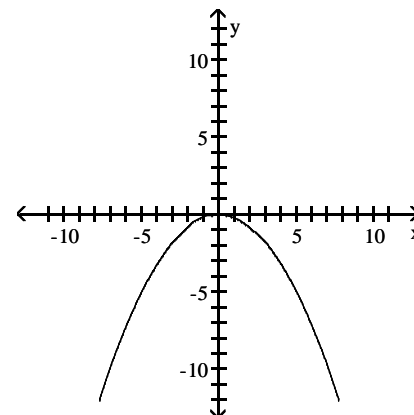

7)  $f(x) = \frac{1}{4}x^2$

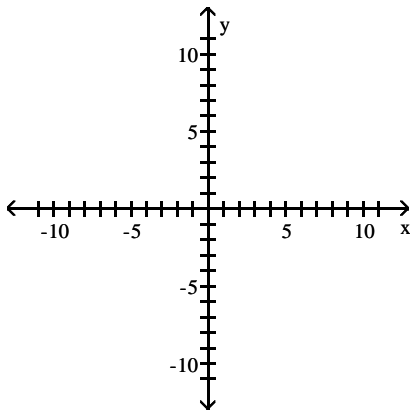

A)

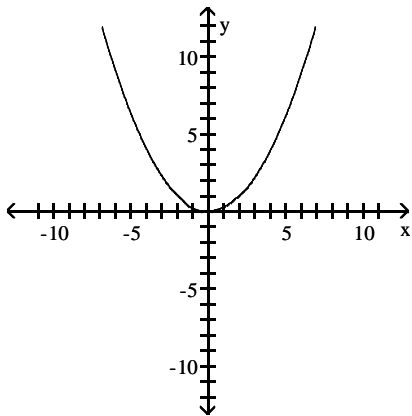

B)

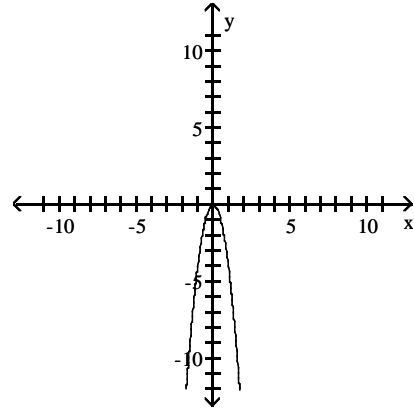

C)

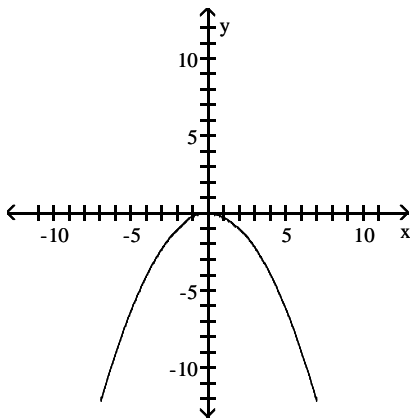

D)

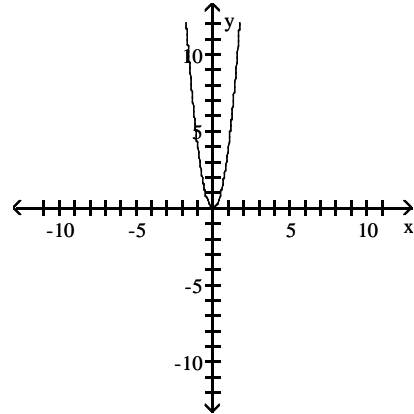

8)  $f(x) = \frac{1}{3}x^2 + 2$

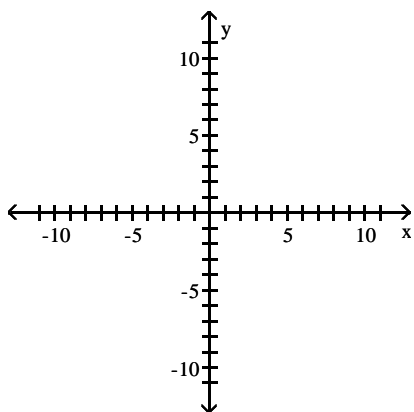

A)

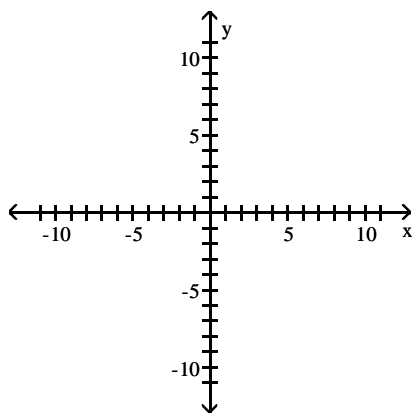

C)

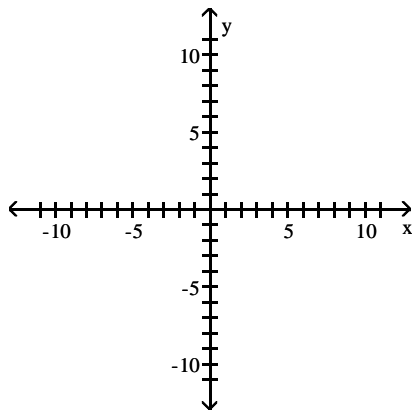

B)

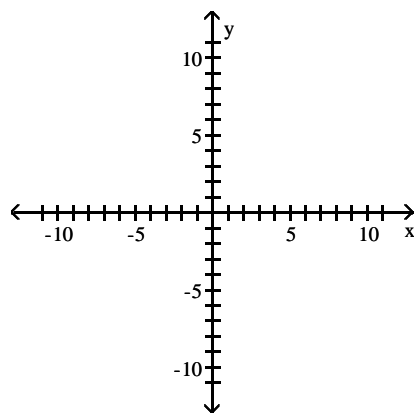

D)

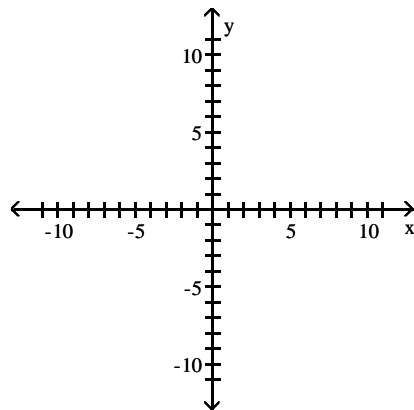

9)  $f(x) = -3x^2 - 1$

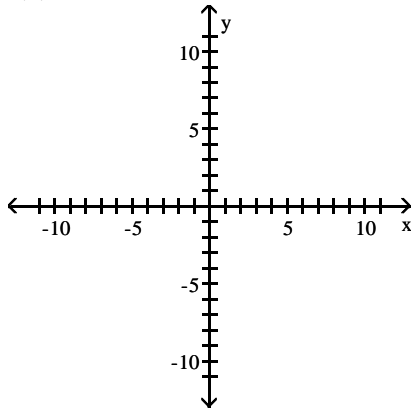

A)

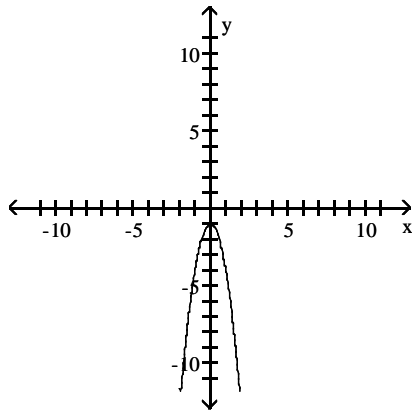

C)

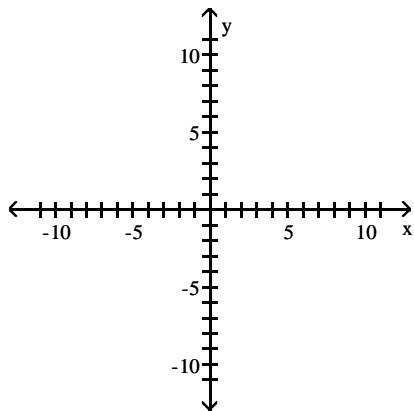

B)

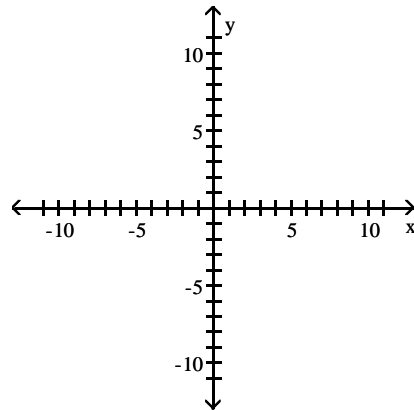

D)

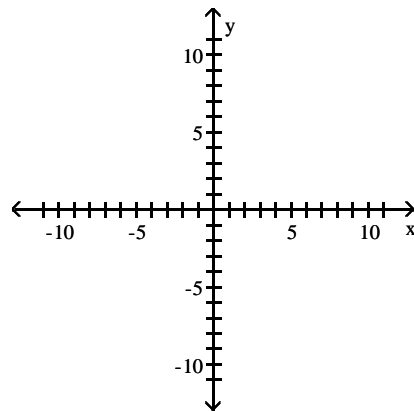

10)  $f(x) = 4x^2 - 6$

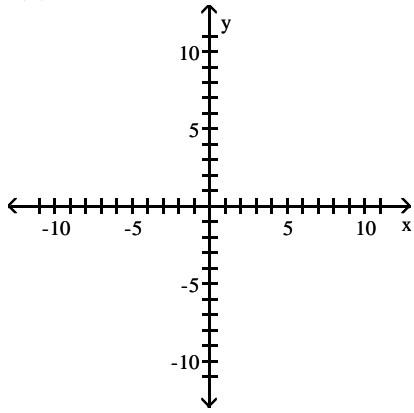

A)

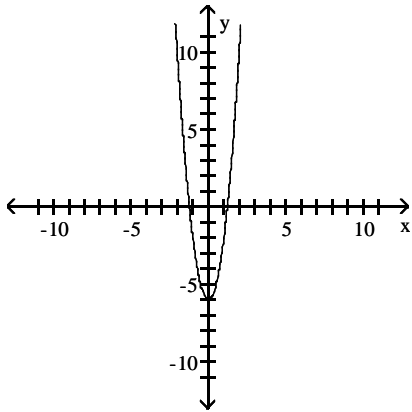

C)

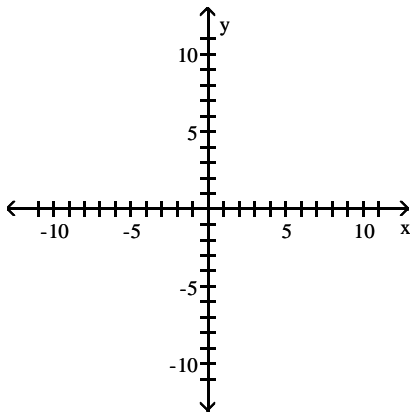

B)

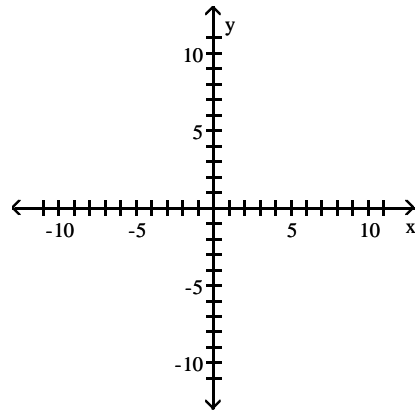

D)

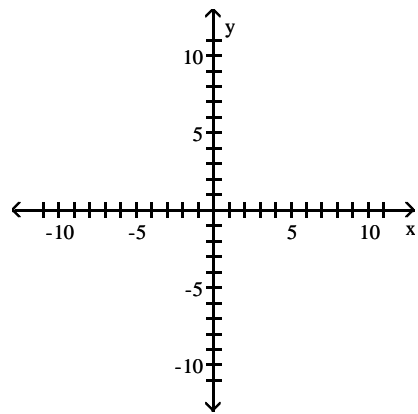

11)  $f(x) = -x^2 - 2x$

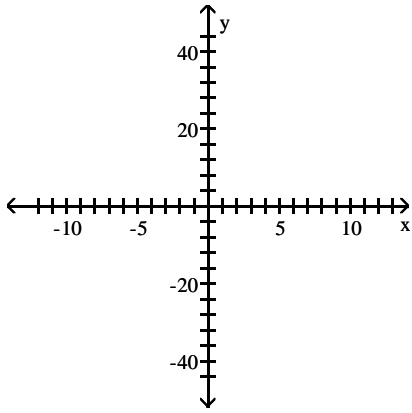

A)

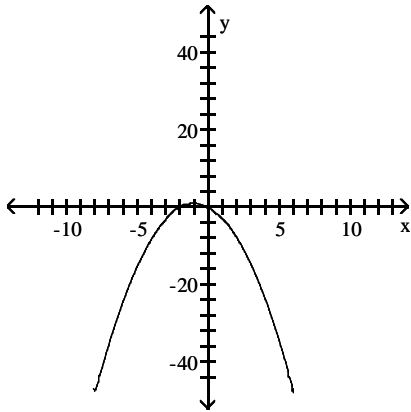

B)

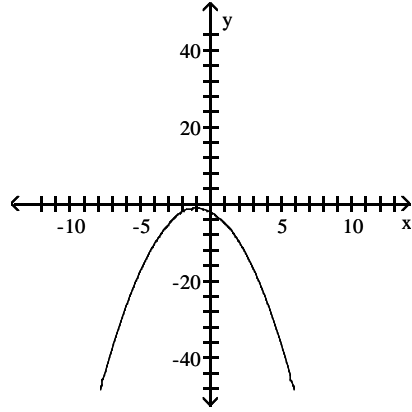

C)

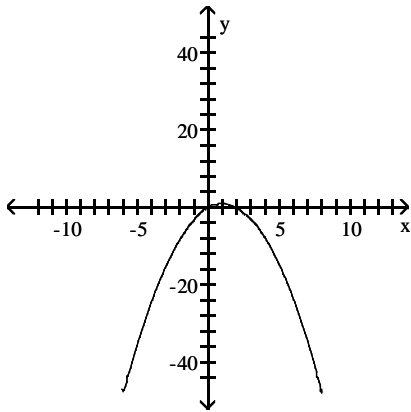

D)

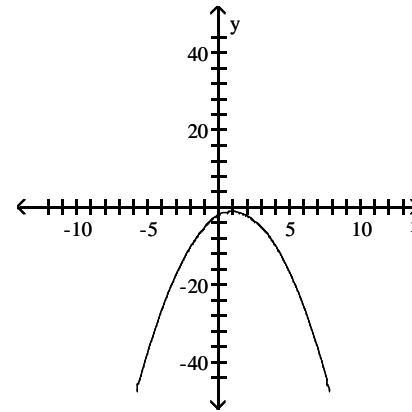

12)  $f(x) = x^2 + 2x - 3$

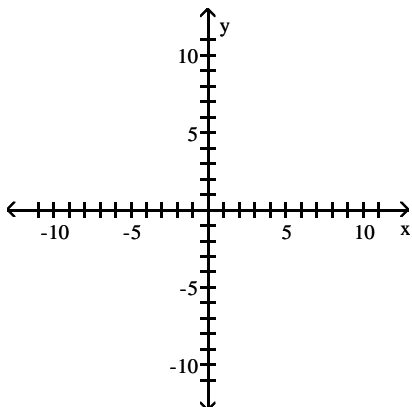



A)

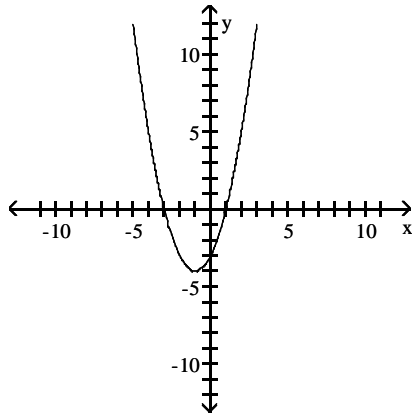

B)

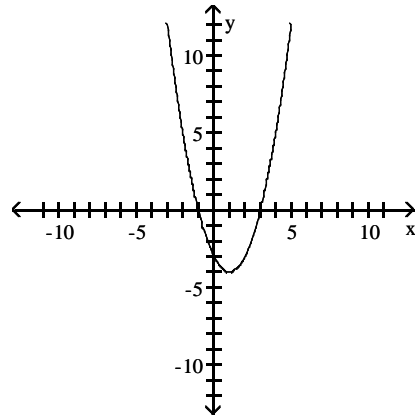

C)

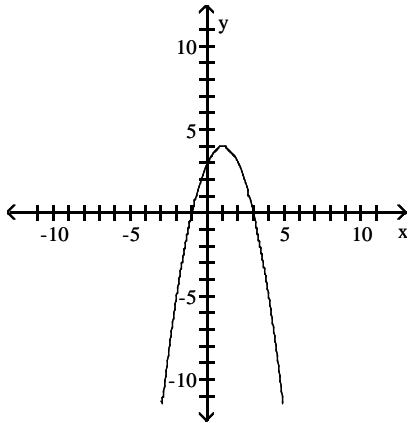

D)

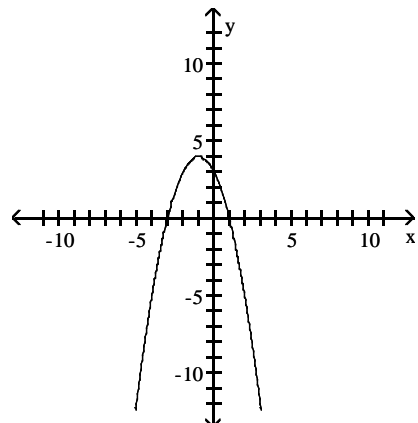

13)  $f(x) = -2x^2 - 4x - 4$

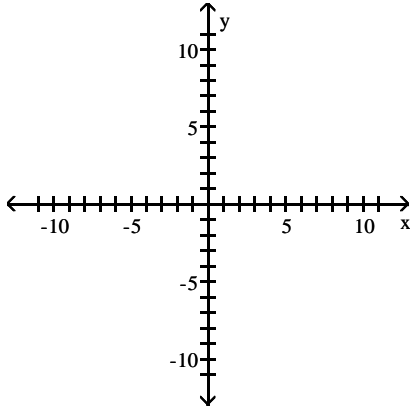

A)

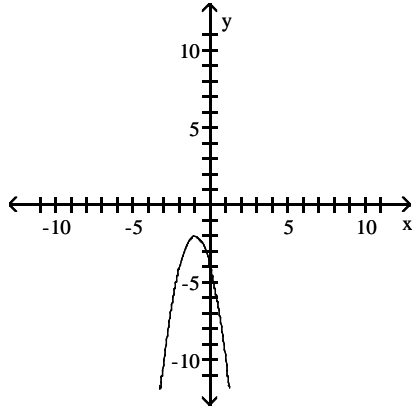

B)

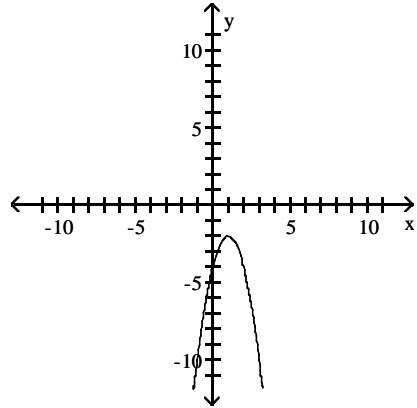

C)

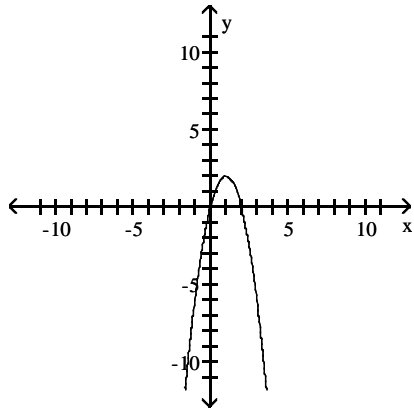

D)

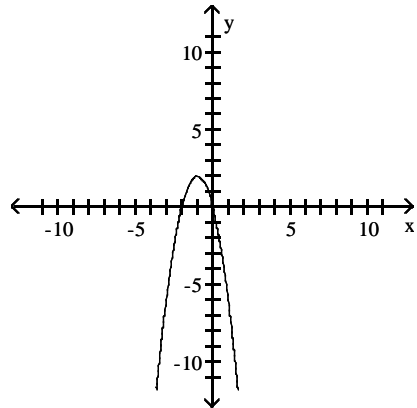

$$14) f(x) = \frac{5}{7}x^2 + \frac{10}{7}x - 1$$

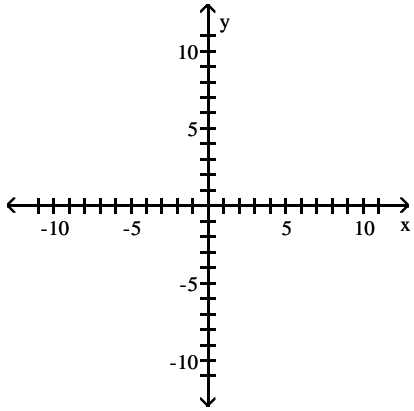

A)

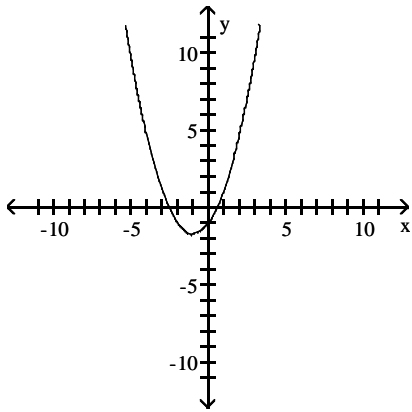

B)

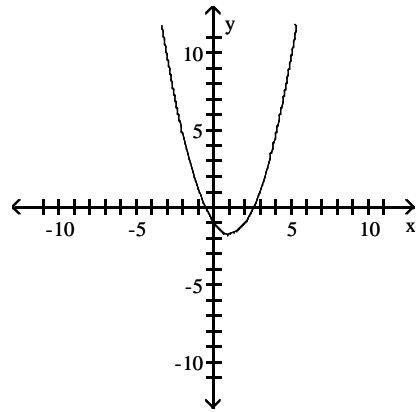

C)

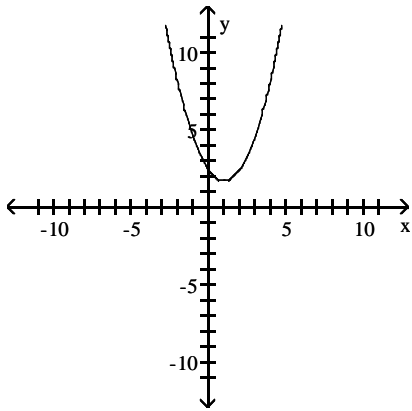

D)

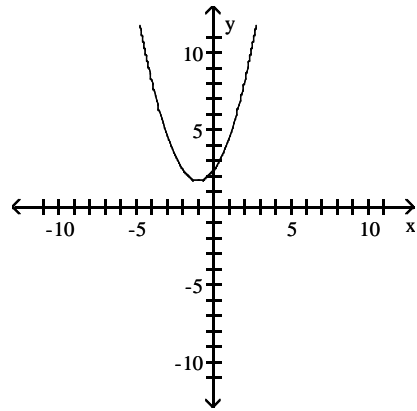

15)  $f(x) = -x^2 + 8x - 10$

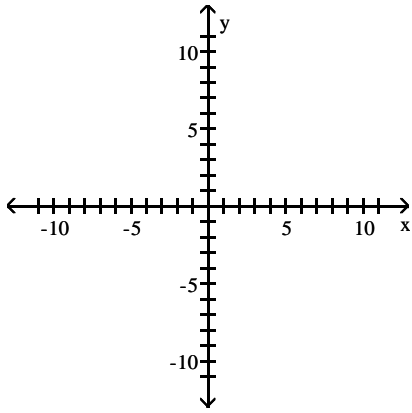

A)

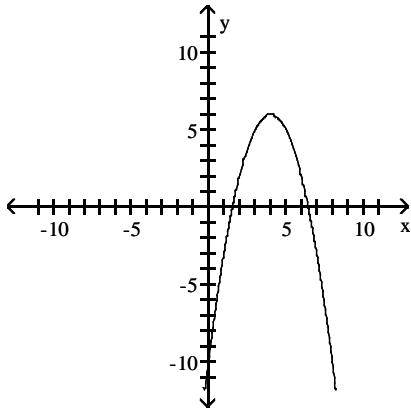

B)

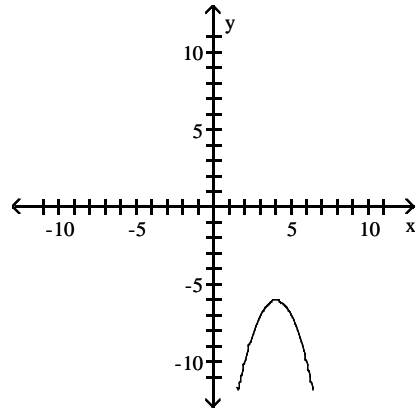

C)

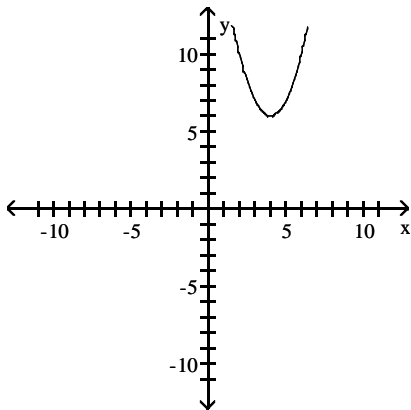

D)

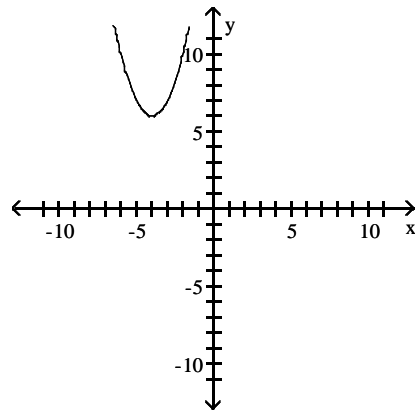

## 2 Identify the Vertex and Axis of Symmetry of a Quadratic Function

**MULTIPLE CHOICE.** Choose the one alternative that best completes the statement or answers the question.

Find the vertex and axis of symmetry of the graph of the function.

1)  $f(x) = x^2 + 6x$

A)  $(-3, -9)$ ;  $x = -3$

B)  $(-9, 3)$ ;  $x = -9$

C)  $(3, -9)$ ;  $x = 3$

D)  $(9, -3)$ ;  $x = 9$

2)  $f(x) = x^2 - 4x$

A)  $(2, -4)$ ;  $x = 2$

B)  $(-4, 2)$ ;  $x = -4$

C)  $(-2, 4)$ ;  $x = -2$

D)  $(4, -2)$ ;  $x = 4$

$$3) f(x) = -x^2 + 6x$$

$$A) (3, 9); x = 3$$

$$B) (-9, 3); x = -9$$

$$C) (-3, -9); x = -3$$

$$D) (9, -3); x = 9$$

$$4) f(x) = -x^2 - 10x$$

$$A) (-5, 25); x = -5$$

$$B) (-25, 5); x = -25$$

$$C) (5, -25); x = 5$$

$$D) (25, -5); x = 25$$

$$5) f(x) = 3x^2 - 12x$$

$$A) (2, -12); x = 2$$

$$B) (-2, -12); x = -2$$

$$C) (2, 0); x = 2$$

$$D) (-2, 0); x = -2$$

$$6) f(x) = x^2 + 4x - 5$$

$$A) (-2, -9); x = -2$$

$$B) (2, -9); x = 2$$

$$C) (2, 9); x = 2$$

$$D) (-2, 9); x = -2$$

$$7) f(x) = -x^2 - 10x + 4$$

$$A) (-5, 29); x = -5$$

$$B) (5, -71); x = 5$$

$$C) (-10, 4); x = -10$$

$$D) (5, -21); x = 5$$

$$8) f(x) = -4x^2 - 8x - 9$$

$$A) (-1, -5); x = -1$$

$$B) (1, -21); x = 1$$

$$C) (-2, -17); x = -2$$

$$D) (2, -41); x = 2$$

$$9) f(x) = x^2 - 5x - 4$$

$$A) \left( \frac{5}{2}, -\frac{41}{4} \right); x = \frac{5}{2}$$

$$B) \left( -\frac{5}{2}, \frac{59}{4} \right); x = -\frac{5}{2}$$

$$C) (7, -4); x = 7$$

$$D) (-5, 46); x = -5$$

$$10) f(x) = -3x^2 - 2x - 12$$

$$A) \left( -\frac{1}{3}, -\frac{35}{3} \right); x = -\frac{1}{3}$$

$$B) (3, -12); x = 3$$

$$C) \left( \frac{1}{3}, \frac{35}{3} \right); x = \frac{1}{3}$$

$$D) \left( -3, -\frac{35}{3} \right); x = -3$$

### 3 Graph a Quadratic Function Using Its Vertex, Axis, and Intercepts

MULTIPLE CHOICE. Choose the one alternative that best completes the statement or answers the question.

Graph the function using its vertex, axis of symmetry, and intercepts.

1)  $f(x) = x^2 - 6x$

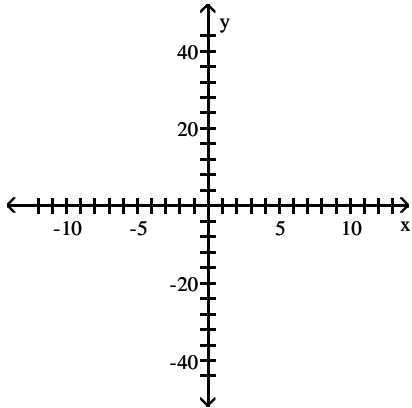

A) vertex (3, -9)  
intercepts (0, 0), (6, 0)

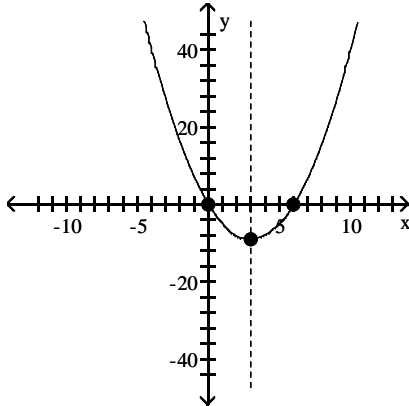

B) vertex (-3, -9)  
intercepts (0, 0), (-6, 0)

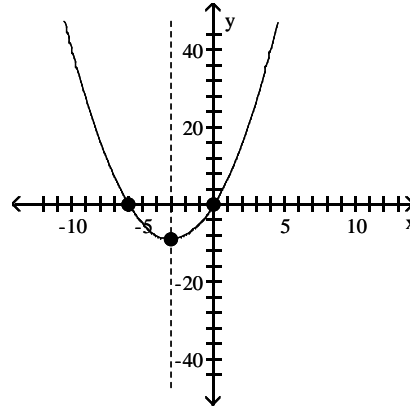

C) vertex (-3, 9)  
intercept (0, 18)

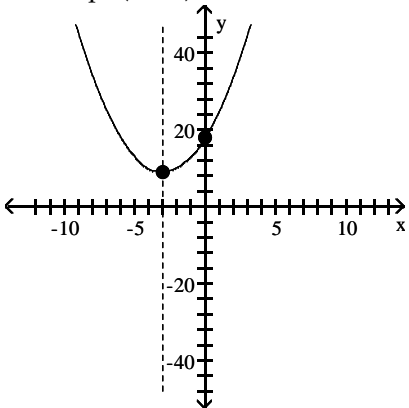

D) vertex (3, 9)  
intercept (0, 18)

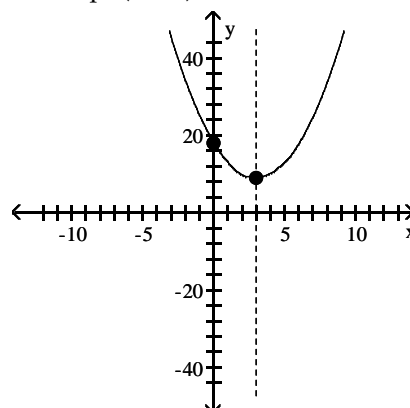

2)  $f(x) = -x^2 - 8x$

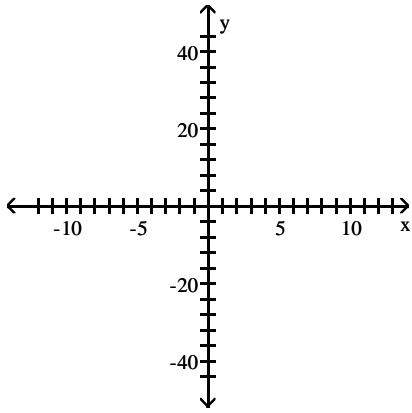

A) vertex  $(-4, 16)$   
intercepts  $(0, 0), (-8, 0)$

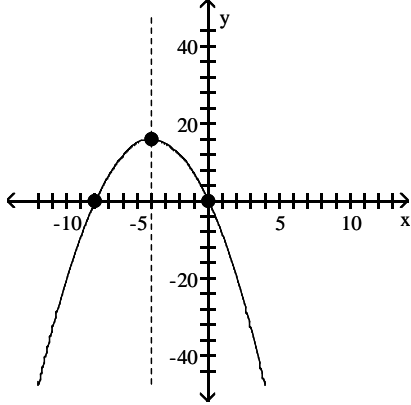

B) vertex  $(-4, -16)$   
intercept  $(0, -32)$

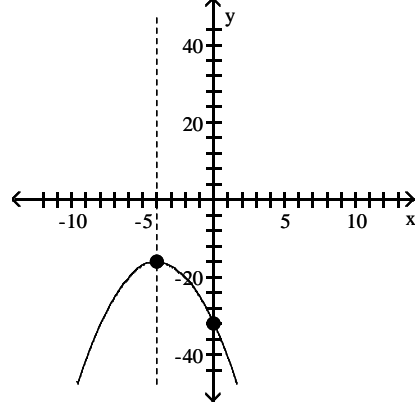

C) vertex  $(4, 16)$   
intercepts  $(0, 0), (8, 0)$

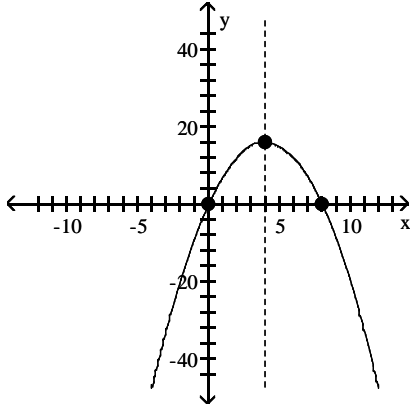

D) vertex  $(4, -16)$   
intercept  $(0, -32)$

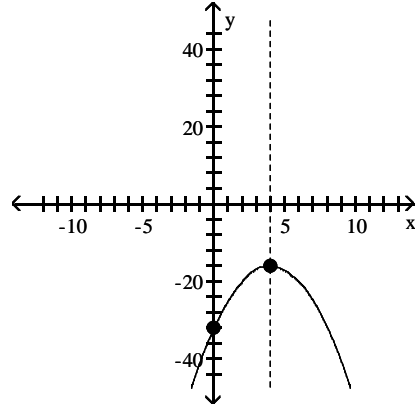

3)  $f(x) = x^2 + 8x + 16$

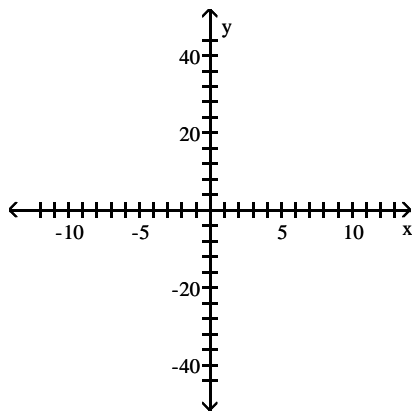

A) vertex  $(-4, 0)$   
intercepts  $(0, 16), (-4, 0)$

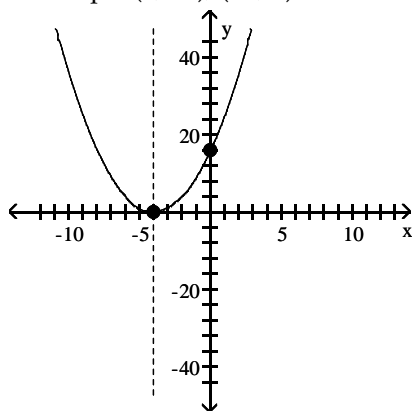

B) vertex  $(4, 0)$   
intercepts  $(0, 16), (4, 0)$

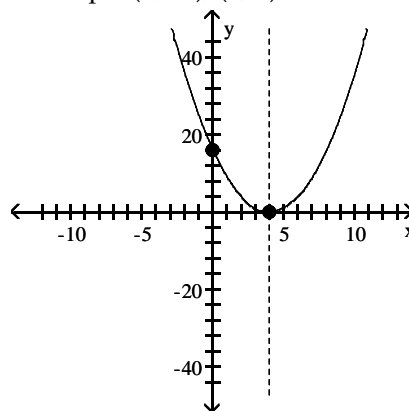

C) vertex  $(4, 16)$   
intercept  $(0, 32)$

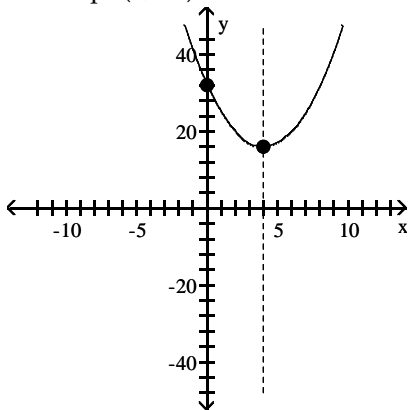

D) vertex  $(-4, 16)$   
intercept  $(0, 32)$

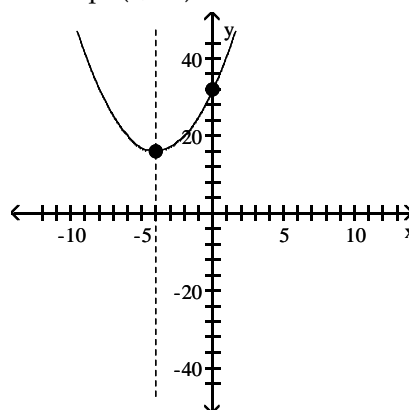



4)  $f(x) = x^2 + 8x + 7$

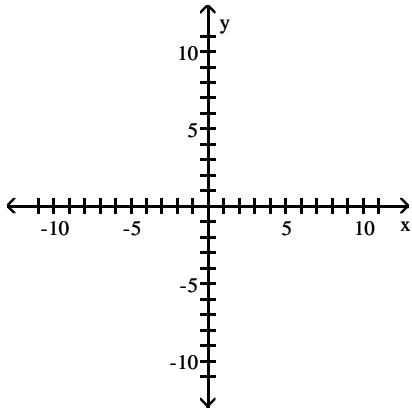

A) vertex  $(-4, -9)$   
intercepts  $(-1, 0)$ ,  $(-7, 0)$ ,  $(0, 7)$

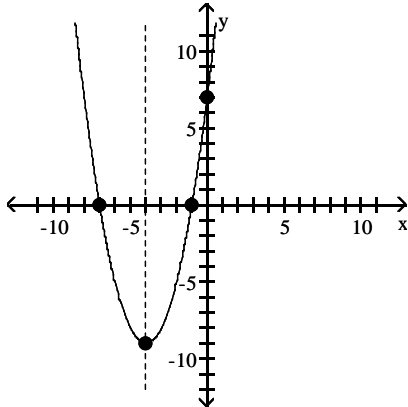

B) vertex  $(4, -9)$   
intercepts  $(1, 0)$ ,  $(7, 0)$ ,  $(0, 7)$

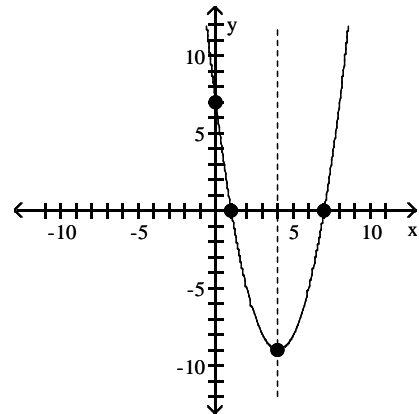

C) vertex  $(4, 9)$   
intercepts  $(1, 0)$ ,  $(7, 0)$ ,  $(0, -7)$

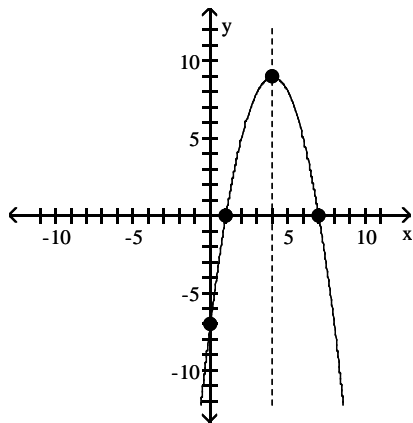

D) vertex  $(-4, 9)$   
intercepts  $(-1, 0)$ ,  $(-7, 0)$ ,  $(0, -7)$

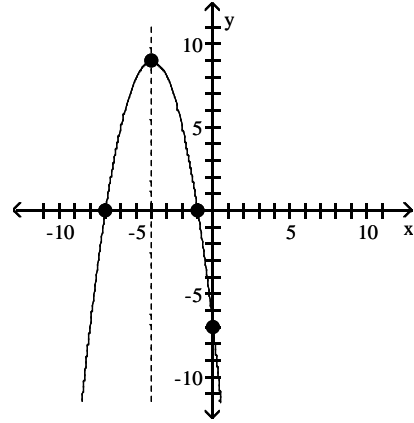

5)  $f(x) = -x^2 - 8x - 7$

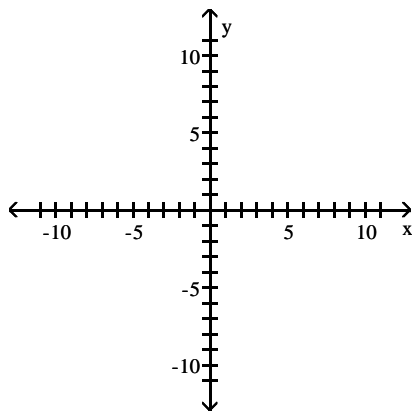

A) vertex  $(-4, 9)$   
intercepts  $(-1, 0)$ ,  $(-7, 0)$ ,  $(0, -7)$

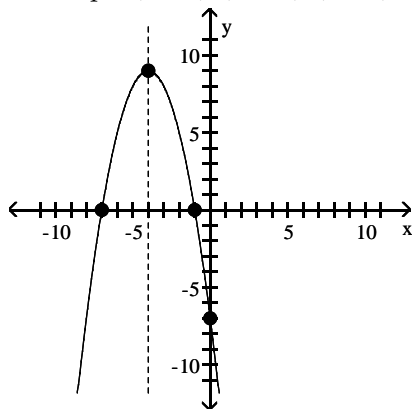

B) vertex  $(4, -9)$   
intercepts  $(1, 0)$ ,  $(7, 0)$ ,  $(0, 7)$

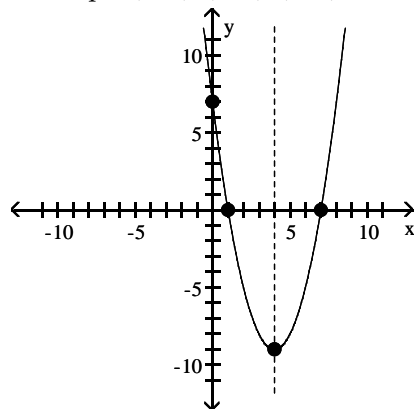

C) vertex  $(4, 9)$   
intercepts  $(1, 0)$ ,  $(7, 0)$ ,  $(0, -7)$

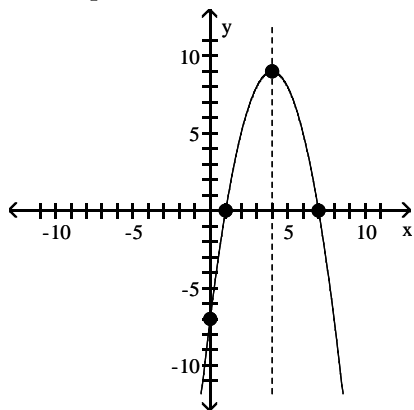

D) vertex  $(-4, -9)$   
intercepts  $(-1, 0)$ ,  $(-7, 0)$ ,  $(0, 7)$

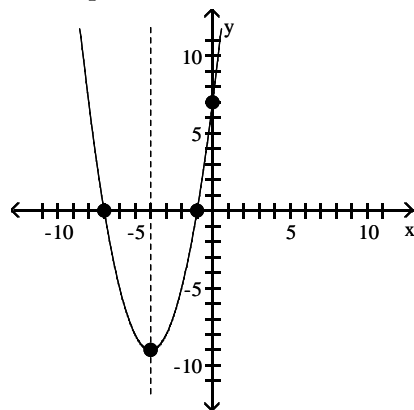

6)  $f(x) = x^2 - 4x - 5$

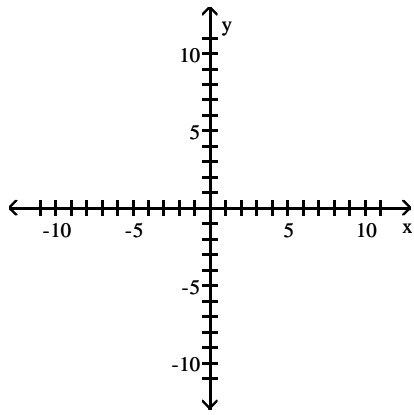

A) vertex  $(2, -9)$   
intercepts  $(5, 0)$ ,  $(-1, 0)$ ,  $(0, -5)$

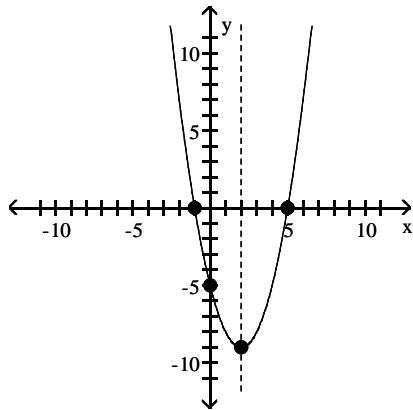

B) vertex  $(-2, -9)$   
intercepts  $(-5, 0)$ ,  $(1, 0)$ ,  $(0, -5)$

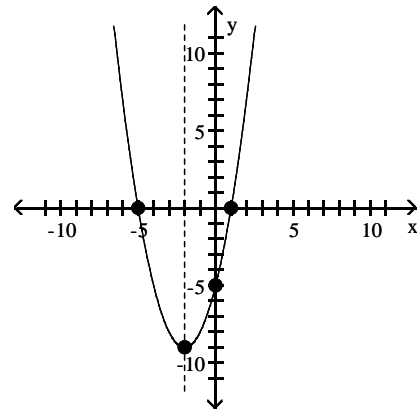

C) vertex  $(-2, 9)$   
intercepts  $(-5, 0)$ ,  $(1, 0)$ ,  $(0, 5)$

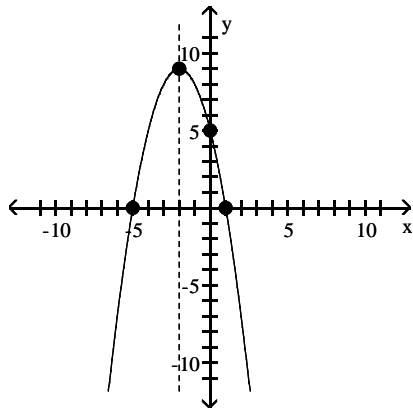

D) vertex  $(2, 9)$   
intercepts  $(5, 0)$ ,  $(-1, 0)$ ,  $(0, 5)$

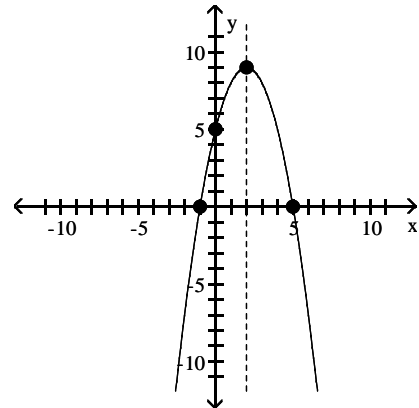

7)  $f(x) = -x^2 + 8x - 7$

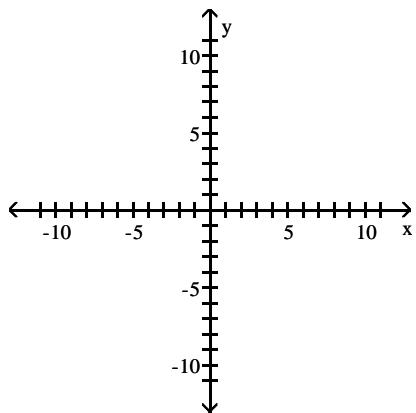

A) vertex (4, 9)  
intercepts (7, 0), (1, 0), (0, -7)

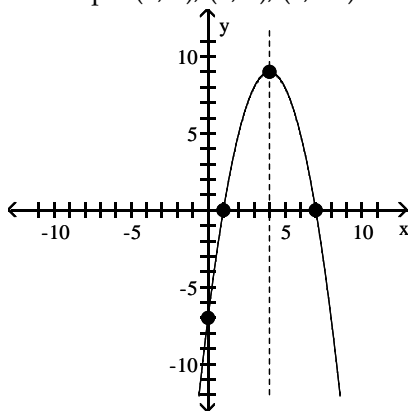

B) vertex (-4, -9)  
intercepts (-7, 0), (-1, 0), (0, 7)

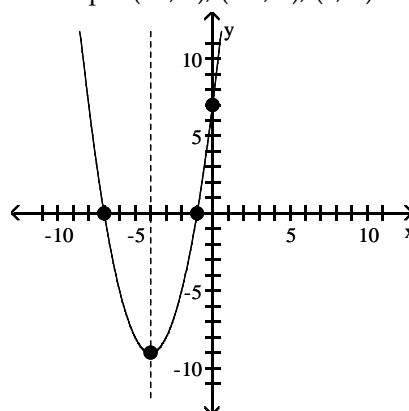

C) vertex (-4, 9)  
intercepts (-7, 0), (-1, 0), (0, -7)

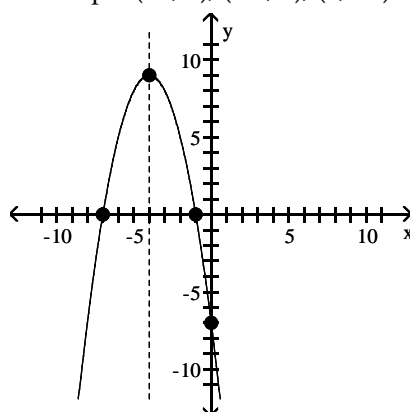

D) vertex (4, -9)  
intercepts (7, 0), (1, 0), (0, 7)

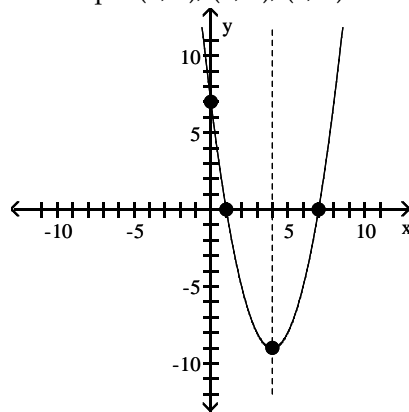

8)  $f(x) = 4x^2 + 40x + 103$

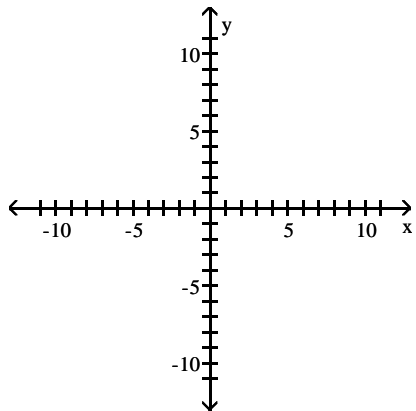

A) vertex  $(-5, 3)$   
intercept  $(0, 103)$

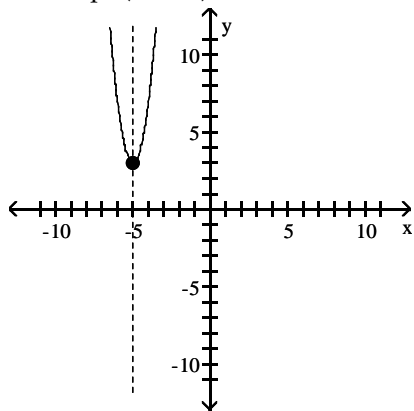

B) vertex  $(5, 3)$   
intercept  $(0, 103)$

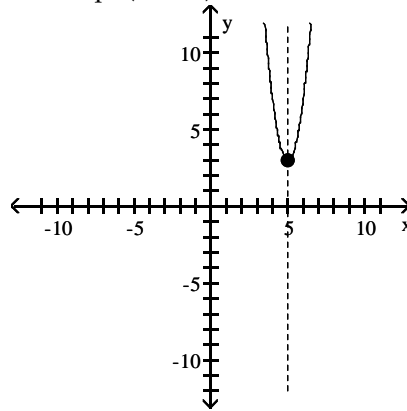

C) vertex  $(-5, 3)$   
intercept  $(0, \frac{37}{4})$

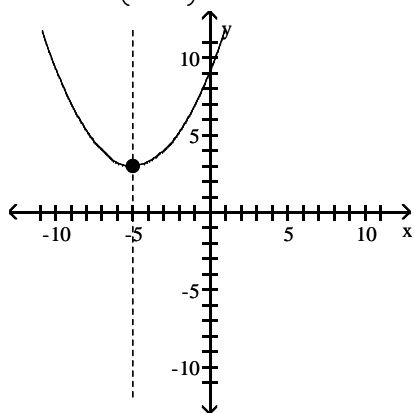

D) vertex  $(5, 3)$   
intercept  $(0, \frac{37}{4})$

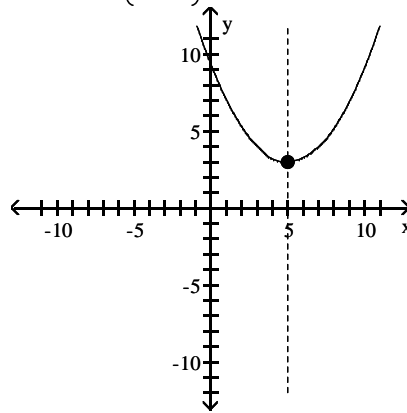

9)  $f(x) = -10x^2 - 2x - 5$

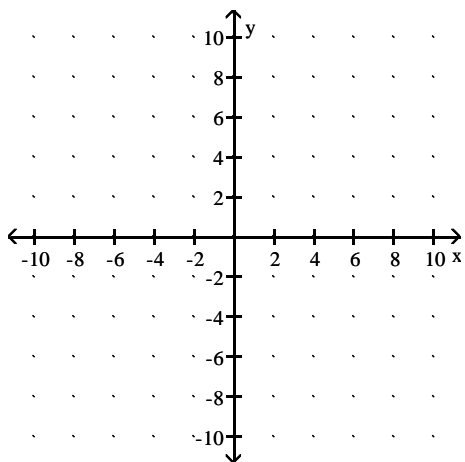

A) vertex  $\left(-\frac{1}{10}, -\frac{49}{10}\right)$   
intercept  $(0, -5)$

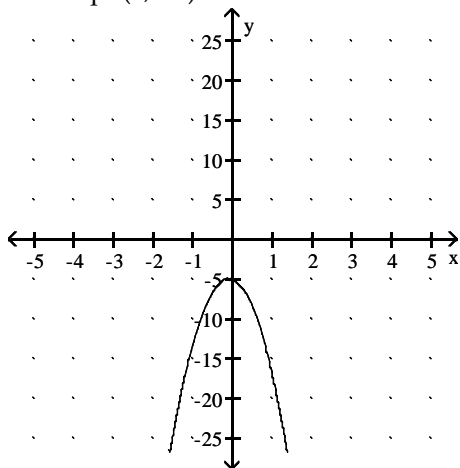

C) vertex  $\left(\frac{1}{10}, -\frac{49}{10}\right)$   
intercept  $(0, -5)$

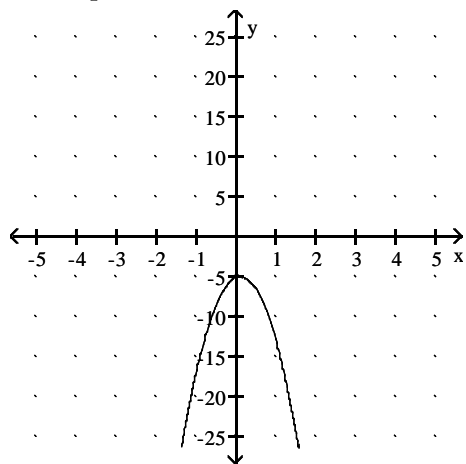

B) vertex  $\left(-\frac{1}{10}, \frac{49}{10}\right)$   
intercept  $(0, 5)$

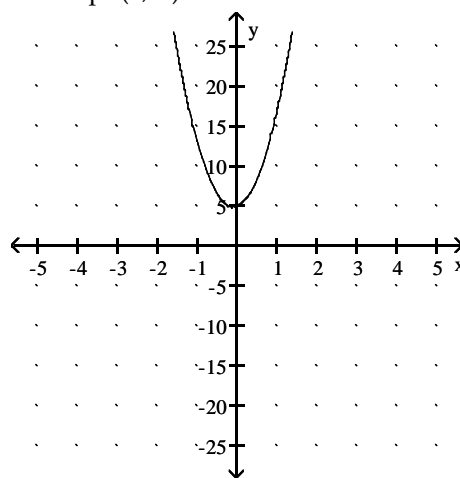

D) vertex  $\left(\frac{1}{10}, \frac{49}{10}\right)$   
intercept  $(0, 5)$

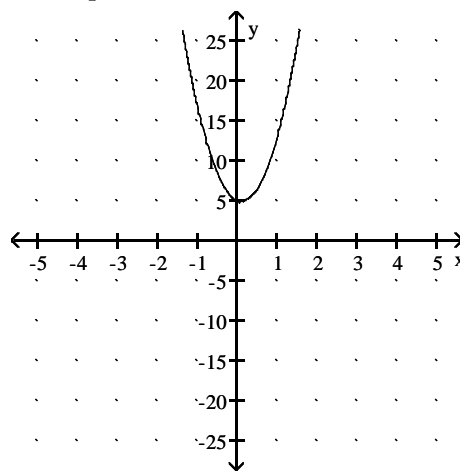

**Determine the domain and the range of the function.**

10)  $f(x) = x^2 + 10x$

- A) domain: all real numbers  
range:  $\{y \mid y \geq -25\}$   
C) domain:  $\{x \mid x \geq 5\}$   
range:  $\{y \mid y \geq 25\}$

- B) domain:  $\{x \mid x \geq -5\}$   
range:  $\{y \mid y \geq -25\}$   
D) domain: all real numbers  
range:  $\{y \mid y \geq 25\}$

11)  $f(x) = -x^2 + 12x$

- A) domain: all real numbers  
range:  $\{y \mid y \leq 36\}$   
C) domain:  $\{x \mid x \leq -6\}$   
range:  $\{y \mid y \leq 36\}$

- B) domain:  $\{x \mid x \leq 6\}$   
range:  $\{y \mid y \leq 36\}$   
D) domain: all real numbers  
range:  $\{y \mid y \leq -36\}$

12)  $f(x) = x^2 - 12x + 36$

- A) domain: all real numbers  
range:  $\{y \mid y \geq 0\}$   
C) domain:  $\{x \mid x \geq -6\}$   
range:  $\{y \mid y \geq 0\}$

- B) domain:  $\{x \mid x \geq 6\}$   
range:  $\{y \mid y \geq 0\}$   
D) domain: all real numbers  
range:  $\{y \mid y \geq 36\}$

13)  $f(x) = x^2 + 4x - 5$

- A) domain: all real numbers  
range:  $\{y \mid y \geq -9\}$   
C) domain: range:  $\{x \mid x \geq 2\}$   
range:  $\{y \mid y \geq 9\}$

- B) domain: range:  $\{x \mid x \geq 2\}$   
range:  $\{y \mid y \geq -9\}$   
D) domain: all real numbers  
range:  $\{y \mid y \geq 9\}$

14)  $f(x) = -x^2 - 4x - 3$

- A) domain: all real numbers  
range:  $\{y \mid y \leq 1\}$   
C) domain:  $\{x \mid x \leq -2\}$   
range:  $\{y \mid y \leq -1\}$

- B) domain:  $\{x \mid x \leq -2\}$   
range:  $\{y \mid y \leq 1\}$   
D) domain: all real numbers  
range:  $\{y \mid y \leq -1\}$

15)  $f(x) = x^2 - 2x - 8$

- A) domain: all real numbers  
range:  $\{y \mid y \geq -9\}$   
C) domain: all real numbers  
range:  $\{y \mid y \leq 9\}$

- B) domain:  $\{x \mid x \geq -1\}$   
range:  $\{y \mid y \geq -9\}$   
D) domain: all real numbers  
range: all real numbers

16)  $f(x) = -x^2 + 4x + 5$

- A) domain: all real numbers  
range:  $\{y \mid y \leq 9\}$   
C) domain: all real numbers  
range:  $\{y \mid y \leq -9\}$

- B) domain:  $\{x \mid x \leq -2\}$   
range:  $\{y \mid y \leq 9\}$   
D) domain: all real numbers  
range: all real numbers

17)  $f(x) = -4x^2 - 2x - 8$

- A) domain: all real numbers  
range:  $\left\{y \mid y \leq -\frac{31}{4}\right\}$   
C) domain: all real numbers  
range:  $\left\{y \mid y \geq \frac{31}{4}\right\}$

- B) domain: all real numbers  
range:  $\left\{y \mid y \geq -\frac{31}{4}\right\}$   
D) domain: all real numbers  
range:  $\left\{y \mid y \leq \frac{31}{4}\right\}$

Determine where the function is increasing and where it is decreasing.

18)  $f(x) = x^2 - 4x$

- A) increasing on  $(2, \infty)$   
decreasing on  $(-\infty, 2)$
- C) increasing on  $(-\infty, -2)$   
decreasing on  $(-2, \infty)$

- B) increasing on  $(-\infty, 2)$   
decreasing on  $(2, \infty)$
- D) increasing on  $(-2, \infty)$   
decreasing on  $(-\infty, -2)$

19)  $f(x) = -x^2 + 10x$

- A) increasing on  $(-\infty, 5)$   
decreasing on  $(5, \infty)$
- C) increasing on  $(-5, \infty)$   
decreasing on  $(-\infty, -5)$

- B) increasing on  $(5, \infty)$   
decreasing on  $(-\infty, 5)$
- D) increasing on  $(-\infty, -5)$   
decreasing on  $(-5, \infty)$

20)  $f(x) = x^2 - 6x + 9$

- A) increasing on  $(3, \infty)$   
decreasing on  $(-\infty, 3)$
- C) increasing on  $(-\infty, -3)$   
decreasing on  $(-3, \infty)$

- B) increasing on  $(-\infty, 3)$   
decreasing on  $(3, \infty)$
- D) increasing on  $(-3, \infty)$   
decreasing on  $(-\infty, -3)$

21)  $f(x) = x^2 + 2x - 8$

- A) increasing on  $(-1, \infty)$   
decreasing on  $(-\infty, -1)$
- C) increasing on  $(-9, \infty)$   
decreasing on  $(-\infty, -9)$

- B) increasing on  $(-\infty, -1)$   
decreasing on  $(-1, \infty)$
- D) increasing on  $(-\infty, -9)$   
decreasing on  $(-9, \infty)$

22)  $f(x) = -x^2 - 6x - 8$

- A) increasing on  $(-\infty, -3)$   
decreasing on  $(-3, \infty)$
- C) increasing on  $(-\infty, 1)$   
decreasing on  $(1, \infty)$

- B) increasing on  $(-3, \infty)$   
decreasing on  $(-\infty, -3)$
- D) increasing on  $(1, \infty)$   
decreasing on  $(-\infty, 1)$

23)  $f(x) = x^2 - 8x + 7$

- A) increasing on  $(4, \infty)$   
decreasing on  $(-\infty, 4)$
- C) increasing on  $(-\infty, -9)$   
decreasing on  $(-9, \infty)$

- B) increasing on  $(-\infty, 4)$   
decreasing on  $(4, \infty)$
- D) increasing on  $(-9, \infty)$   
decreasing on  $(-\infty, -9)$

24)  $f(x) = -x^2 + 2x + 8$

- A) increasing on  $(-\infty, 1)$   
decreasing on  $(1, \infty)$
- C) increasing on  $(9, \infty)$   
decreasing on  $(-\infty, 9)$

- B) increasing on  $(1, \infty)$   
decreasing on  $(-\infty, 1)$
- D) increasing on  $(-\infty, 9)$   
decreasing on  $(9, \infty)$

25)  $g(x) = 6x^2 + 96x + 348$

- A) decreasing on  $(-\infty, -8)$   
increasing on  $(-8, \infty)$
- C) decreasing on  $(-\infty, 8)$   
increasing on  $(8, \infty)$

- B) increasing on  $(-\infty, -48)$   
decreasing on  $(-48, \infty)$
- D) increasing on  $(-\infty, -8)$   
decreasing on  $(-8, \infty)$



26)  $f(x) = -12x^2 - 2x - 2$

- A) increasing on  $\left(-\infty, -\frac{1}{12}\right)$   
decreasing on  $\left(-\frac{1}{12}, \infty\right)$
- C) increasing on  $\left(-\infty, \frac{1}{12}\right)$   
decreasing on  $\left(\frac{1}{12}, \infty\right)$

- B) decreasing on  $\left(-\infty, -\frac{1}{12}\right)$   
increasing on  $\left(-\frac{1}{12}, \infty\right)$
- D) increasing on  $\left(-\infty, -\frac{23}{12}\right)$   
decreasing on  $\left(-\frac{23}{12}, \infty\right)$

**4 Find a Quadratic Function Given Its Vertex and One Other Point**

**MULTIPLE CHOICE.** Choose the one alternative that best completes the statement or answers the question.

Determine the quadratic function whose graph is given.

1)

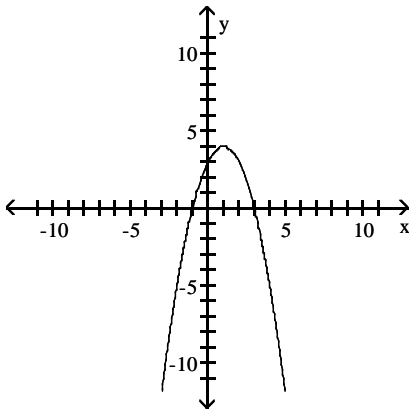

Vertex: (1, 4)

y-intercept: (0, 3)

A)  $f(x) = -x^2 + 2x + 3$

B)  $f(x) = -x^2 + 2x - 3$

C)  $f(x) = x^2 - 4x + 3$

D)  $f(x) = -x^2 - 4x + 3$

2)

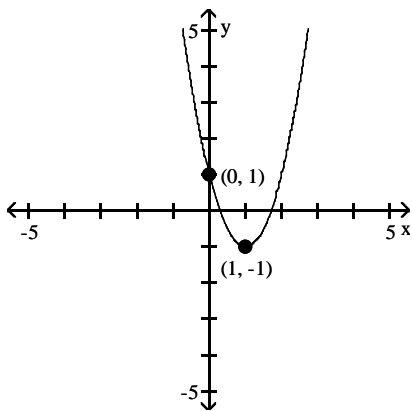

A)  $f(x) = 2x^2 - 4x + 1$

B)  $f(x) = -2x^2 + 4x - 1$

C)  $f(x) = 2x^2 + 8x + 1$

D)  $f(x) = -2x^2 - 4x + 1$

## 5 Find the Maximum or Minimum Value of a Quadratic Function

**MULTIPLE CHOICE.** Choose the one alternative that best completes the statement or answers the question.

**Determine, without graphing, whether the given quadratic function has a maximum value or a minimum value and then find that value.**

1)  $f(x) = x^2 + 7$

A) minimum; 7

B) minimum; 0

C) maximum; 0

D) maximum; 7

2)  $f(x) = x^2 - 7$

A) minimum; -7

B) minimum; 0

C) maximum; -7

D) maximum; 0

3)  $f(x) = x^2 - 2x + 1$

A) minimum; 0

B) maximum; 0

C) minimum; 1

D) maximum; 1

4)  $f(x) = -x^2 - 2x - 1$

A) maximum; 0

B) minimum; 0

C) minimum; -1

D) maximum; -1

5)  $f(x) = 4x^2 + 2x - 5$

A) minimum;  $-\frac{21}{4}$

B) maximum;  $-\frac{21}{4}$

C) minimum;  $-\frac{1}{4}$

D) maximum;  $-\frac{1}{4}$

6)  $f(x) = 5x^2 + 15x$

A) minimum;  $-\frac{45}{4}$

B) maximum;  $-\frac{45}{4}$

C) minimum;  $-\frac{3}{2}$

D) maximum;  $-\frac{3}{2}$

7)  $f(x) = -2x^2 - 2x$

A) maximum;  $\frac{1}{2}$

B) minimum;  $\frac{1}{2}$

C) minimum;  $-\frac{1}{2}$

D) maximum;  $-\frac{1}{2}$

8)  $f(x) = -2x^2 - 2x - 9$

A) maximum;  $-\frac{17}{2}$

B) minimum;  $-\frac{17}{2}$

C) maximum;  $\frac{17}{2}$

D) minimum;  $\frac{17}{2}$

**Solve the problem.**

9) The manufacturer of a CD player has found that the revenue  $R$  (in dollars) is

$R(p) = -5p^2 + 1450p$ , when the unit price is  $p$  dollars. If the manufacturer sets the price  $p$  to maximize revenue, what is the maximum revenue to the nearest whole dollar?

A) \$105,125

B) \$210,250

C) \$420,500

D) \$841,000

10) The owner of a video store has determined that the cost  $C$ , in dollars, of operating the store is approximately given by  $C(x) = 2x^2 - 26x + 510$ , where  $x$  is the number of videos rented daily. Find the lowest cost to the nearest dollar.

A) \$426

B) \$172

C) \$341

D) \$595

11) The price  $p$  and the quantity  $x$  sold of a certain product obey the demand equation

$$p = -\frac{1}{3}x + 200, \quad 0 \leq x \leq 600.$$

What quantity  $x$  maximizes revenue? What is the maximum revenue?

A) 300; \$30,000

B) 150; \$22,500

C) 450; \$22,500

D) 600; \$30,000

12) The price  $p$  and the quantity  $x$  sold of a certain product obey the demand equation

$$p = -\frac{1}{8}x + 140, \quad 0 \leq x \leq 1120.$$

What price should the company charge to maximize revenue?

- A) \$70                                      B) \$84                                      C) \$105                                      D) \$35

13) The price  $p$  (in dollars) and the quantity  $x$  sold of a certain product obey the demand equation

$$x = -9p + 216, \quad 0 \leq p \leq 24.$$

What quantity  $x$  maximizes revenue? What is the maximum revenue?

- A) 108; \$1296                                      B) 54; \$972                                      C) 162; \$972                                      D) 216; \$1296

14) The price  $p$  (in dollars) and the quantity  $x$  sold of a certain product obey the demand equation

$$p = -5x + 120, \quad 0 \leq x \leq 24.$$

What price should the company charge to maximize revenue?

- A) \$12                                      B) \$14.4                                      C) \$18                                      D) \$6

15) The profit that the vendor makes per day by selling  $x$  pretzels is given by the function

$$P(x) = -0.004x^2 + 2.4x - 300. \text{ Find the number of pretzels that must be sold to maximize profit.}$$

- A) 300 pretzels                                      B) 600 pretzels                                      C) 1.2 pretzels                                      D) 60 pretzels

16) The owner of a video store has determined that the profits  $P$  of the store are approximately given by

$$P(x) = -x^2 + 110x + 51, \text{ where } x \text{ is the number of videos rented daily. Find the maximum profit to the nearest dollar.}$$

- A) \$3076                                      B) \$3025                                      C) \$6101                                      D) \$6050

17) You have 288 feet of fencing to enclose a rectangular region. Find the dimensions of the rectangle that maximize the enclosed area.

- A) 72 ft by 72 ft                                      B) 144 ft by 144 ft                                      C) 144 ft by 36 ft                                      D) 74 ft by 70 ft

18) A developer wants to enclose a rectangular grassy lot that borders a city street for parking. If the developer has 344 feet of fencing and does not fence the side along the street, what is the largest area that can be enclosed?

- A) 14,792 ft<sup>2</sup>                                      B) 29,584 ft<sup>2</sup>                                      C) 7396 ft<sup>2</sup>                                      D) 22,188 ft<sup>2</sup>

19) You have 212 feet of fencing to enclose a rectangular region. What is the maximum area?

- A) 2809 square feet                                      B) 11,236 square feet                                      C) 44,944 square feet                                      D) 2805 square feet

20) You have 64 feet of fencing to enclose a rectangular plot that borders on a river. If you do not fence the side along the river, find the length and width of the plot that will maximize the area.

- A) length: 32 feet, width: 16 feet                                      B) length: 48 feet, width: 16 feet  
C) length: 32 feet, width: 32 feet                                      D) length: 16 feet, width: 16 feet

21) A projectile is fired from a cliff 100 feet above the water at an inclination of 45° to the horizontal, with a muzzle velocity of 100 feet per second. The height  $h$  of the projectile above the water is given by

$$h(x) = \frac{-32x^2}{(100)^2} + x + 100, \text{ where } x \text{ is the horizontal distance of the projectile from the base of the cliff. Find}$$

the maximum height of the projectile.

- A) 178.13 ft                                      B) 156.25 ft                                      C) 78.13 ft                                      D) 334.38 ft

- 22) A projectile is fired from a cliff 400 feet above the water at an inclination of  $45^\circ$  to the horizontal, with a muzzle velocity of 130 feet per second. The height  $h$  of the projectile above the water is given by

$$h(x) = \frac{-32x^2}{(130)^2} + x + 400, \text{ where } x \text{ is the horizontal distance of the projectile from the base of the cliff. How}$$

far from the base of the cliff is the height of the projectile a maximum?

- A) 264.06 ft                      B) 532.03 ft                      C) 132.03 ft                      D) 796.09 ft
- 23) Consider the quadratic model  $h(t) = -16t^2 + 40t + 50$  for the height (in feet),  $h$ , of an object  $t$  seconds after the object has been projected straight up into the air. Find the maximum height attained by the object. How much time does it take to fall back to the ground? Assume that it takes the same time for going up and coming down.
- A) maximum height = 75 ft; time to reach ground = 2.5 seconds  
B) maximum height = 75 ft; time to reach ground = 1.25 seconds  
C) maximum height = 50 ft; time to reach ground = 1.25 seconds  
D) maximum height = 50 ft; time to reach ground = 2.5 seconds

- 24) An object is propelled vertically upward from the top of a 32-foot building. The quadratic function  $s(t) = -16t^2 + 96t + 32$  models the ball's height above the ground,  $s(t)$ , in feet,  $t$  seconds after it was thrown. How many seconds does it take until the object finally hits the ground? Round to the nearest tenth of a second if necessary.

- A) 6.3 seconds                      B) 0.3 seconds                      C) 3 seconds                      D) 2 seconds

**SHORT ANSWER. Write the word or phrase that best completes each statement or answers the question.**

- 25) A suspension bridge has twin towers that are 1300 feet apart. Each tower extends 180 feet above the road surface. The cables are parabolic in shape and are suspended from the tops of the towers. The cables touch the road surface at the center of the bridge. Find the height of the cable at a point 200 feet from the center of the bridge.

**MULTIPLE CHOICE. Choose the one alternative that best completes the statement or answers the question.**

- 26) Alan is building a garden shaped like a rectangle with a semicircle attached to one short side. If he has 40 feet of fencing to go around it, what dimensions will give him the maximum area in the garden?
- A) width =  $\frac{80}{\pi + 4} \approx 11.2$ , length = 5.6                      B) width =  $\frac{40}{\pi + 4} \approx 5.6$ , length = 11.2  
C) width =  $\frac{80}{\pi + 8} \approx 7.2$ , length = 10.8                      D) width =  $\frac{80}{\pi + 4} \approx 11.2$ , length = 14.4
- 27) The quadratic function  $f(x) = 0.0039x^2 - 0.44x + 36.40$  models the median, or average, age,  $y$ , at which U.S. men were first married  $x$  years after 1900. In which year was this average age at a minimum? (Round to the nearest year.) What was the average age at first marriage for that year? (Round to the nearest tenth.)
- A) 1956, 24 years old                      B) 1956, 48.8 years old  
C) 1936, 48.8 years old                      D) 1952, 36 years old

## 2.5 Inequalities Involving Quadratic Functions

### 1 Solve Inequalities Involving a Quadratic Function

**MULTIPLE CHOICE.** Choose the one alternative that best completes the statement or answers the question.

**Solve the inequality.**

1)  $x^2 - 3x - 28 \leq 0$

A)  $[-4, 7]$

B)  $(-\infty, -4]$

C)  $[7, \infty)$

D)  $(-\infty, -4]$  or  $[7, \infty)$

2)  $x^2 + 9x + 18 > 0$

A)  $(-\infty, -6)$  or  $(-3, \infty)$

B)  $(-6, -3)$

C)  $(-\infty, -6)$

D)  $(-3, \infty)$

3)  $x^2 - 6x \geq 0$

A)  $(-\infty, 0]$  or  $[6, \infty)$

B)  $[0, 6]$

C)  $(-\infty, -6]$  or  $[0, \infty)$

D)  $[-6, 0]$

4)  $x^2 + 8x \geq 0$

A)  $(-\infty, -8]$  or  $[0, \infty)$

B)  $[0, 8]$

C)  $(-\infty, 0]$  or  $[8, \infty)$

D)  $[-8, 0]$

5)  $x^2 + 6x \leq 0$

A)  $[-6, 0]$

B)  $[0, 6]$

C)  $(-\infty, -6]$  or  $[0, \infty)$

D)  $(-\infty, 0]$  or  $[6, \infty)$

6)  $x^2 - 6x \leq 0$

A)  $[0, 6]$

B)  $[-6, 0]$

C)  $(-\infty, -6]$  or  $[0, \infty)$

D)  $(-\infty, 0]$  or  $[6, \infty)$

7)  $x^2 - 25 > 0$

A)  $(-\infty, -5)$  or  $(5, \infty)$

C)  $(-\infty, -25)$  or  $(25, \infty)$

B)  $(-5, 5)$

D)  $(-25, 25)$

8)  $x^2 - 9 \leq 0$

A)  $[-3, 3]$

B)  $(-\infty, -3]$  or  $[3, \infty)$

C)  $(-\infty, -9]$  or  $[9, \infty)$

D)  $[-9, 9]$

9)  $x^2 + 5x \geq -6$

A)  $(-\infty, -3]$  or  $[-2, \infty)$

B)  $[-3, -2]$

C)  $(-\infty, -3]$

D)  $[-2, \infty)$

10)  $5x^2 - 2 < -9x$

A)  $\left(-2, \frac{1}{5}\right)$

B)  $\left(\frac{1}{5}, 2\right)$

C)  $\left(-2, -\frac{1}{5}\right)$

D)  $\left(-\frac{1}{5}, 2\right)$

11)  $16x^2 + 25 < 40x$

A) No real solution

B)  $\left(-\infty, \frac{5}{4}\right)$

C)  $\left(-\infty, -\frac{5}{4}\right)$

D)  $\left(-\frac{5}{4}, \infty\right)$

12)  $42(x^2 - 1) > 13x$

A)  $\left(-\infty, -\frac{6}{7}\right)$  or  $\left(\frac{7}{6}, \infty\right)$

B)  $\left(-\frac{6}{7}, \frac{7}{6}\right)$

C)  $\left(-\infty, -\frac{7}{6}\right)$  or  $\left(\frac{6}{7}, \infty\right)$

D)  $\left(-\frac{7}{6}, \frac{6}{7}\right)$

**Solve the problem.**

- 13) If  $f(x) = 6x^2 - 5x$  and  $g(x) = 2x + 3$ , solve for  $f(x) = g(x)$   
A)  $\left\{-\frac{1}{2}, 1\right\}$  B)  $\left\{\frac{3}{2}, -\frac{1}{3}\right\}$  C)  $\left\{\frac{1}{6}, 1\right\}$  D)  $\left\{\frac{1}{3}, -\frac{3}{2}\right\}$
- 14) If  $f(x) = 6x^2 - 5x$  and  $g(x) = 2x + 3$ , solve  $f(x) \leq g(x)$ .  
A)  $\left[-\frac{1}{3}, \frac{3}{2}\right]$  B)  $\left[-\frac{3}{2}, \frac{1}{3}\right]$  C)  $\left[-\frac{1}{3}, \frac{3}{2}\right]$  D)  $\left[-\frac{1}{3}, \frac{3}{2}\right]$
- 15) If  $g(x) = 28x^2 - 28$  and  $h(x) = 33x$ , then solve  $g(x) > h(x)$ .  
A)  $\left(-\infty, -\frac{4}{7}\right)$  or  $\left(\frac{7}{4}, \infty\right)$  B)  $\left(-\frac{7}{4}, \frac{4}{7}\right)$  C)  $\left(-\frac{4}{7}, \frac{7}{4}\right)$  D)  $\left(-\infty, -\frac{7}{4}\right)$  or  $\left(\frac{4}{7}, \infty\right)$
- 16) If  $h(x) = x^2 - 9x + 20$ , solve  $h(x) > 0$ .  
A)  $(-\infty, 4)$  or  $(5, \infty)$  B)  $(4, 5)$  C)  $(-\infty, 4)$  D)  $(5, \infty)$
- 17) If  $g(x) = x^2 - 2x - 15$ , solve  $g(x) \leq 0$ .  
A)  $[-3, 5]$  B)  $(-\infty, -3]$  C)  $[5, \infty)$  D)  $(-\infty, -3]$  or  $[5, \infty)$
- 18) The revenue achieved by selling  $x$  graphing calculators is figured to be  $x(45 - 0.2x)$  dollars. The cost of each calculator is \$29. How many graphing calculators must be sold to make a profit (revenue - cost) of at least \$312.80?  
A)  $\{x | 34 < x < 46\}$  B)  $\{x | 14 < x < 26\}$  C)  $\{x | 35 < x < 33\}$  D)  $\{x | 36 < x < 44\}$
- 19) A rock falls from a tower that is 304 ft high. As it is falling, its height is given by the formula  $h = 304 - 16t^2$ . How many seconds will it take for the rock to hit the ground ( $h=0$ )?  
A) 4.4 s B) 17.4 s C) 5776 s D) 17 s
- 20) A rock falls from a tower that is 68.6 m high. As it is falling, its height is given by the formula  $h = 68.6 - 4.9t^2$ . How many seconds will it take for the rock to hit the ground ( $h=0$ )?  
A) 3.7 s B) 8.3 s C) 1000 s D) 8 s
- 21) A flare fired from the bottom of a gorge is visible only when the flare is above the rim. If it is fired with an initial velocity of 128 ft/sec, and the gorge is 192 ft deep, during what interval can the flare be seen? ( $h = -16t^2 + v_0t + h_0$ )  
A)  $2 < t < 6$  B)  $4 < t < 8$  C)  $0 < t < 2$  D)  $6 < t < 10$
- 22) A coin is tossed upward from a balcony 188 ft high with an initial velocity of 32 ft/sec. During what interval of time will the coin be at a height of at least 60 ft? ( $h = -16t^2 + v_0t + h_0$ )  
A)  $0 \leq t \leq 4$  B)  $0 \leq t \leq 1$  C)  $4 \leq t \leq 8$  D)  $3 \leq t \leq 4$
- 23) If a rocket is propelled upward from ground level, its height in meters after  $t$  seconds is given by  $h = -9.8t^2 + 49t$ . During what interval of time will the rocket be higher than 58.8 m?  
A)  $2 < t < 3$  B)  $0 < t < 2$  C)  $3 < t < 4$  D)  $4 < t < 5$
- 24) A flare fired from the bottom of a gorge is visible only when the flare is above the rim. If it is fired with an initial velocity of 96 ft/sec, and the gorge is 128 ft deep, during what interval can the flare be seen? ( $h = -16t^2 + v_0t + h_0$ )  
A)  $2 < t < 4$  B)  $4 < t < 6$  C)  $0 < t < 2$  D)  $6 < t < 8$

- 25) A coin is tossed upward from a balcony 230 ft high with an initial velocity of 48 ft/sec. During what interval of time will the coin be at a height of at least 70 ft?

$$(h = -16t^2 + v_0t + h_0.)$$

- A)  $0 \leq t \leq 5$                       B)  $0 \leq t \leq 1$                       C)  $5 \leq t \leq 10$                       D)  $4 \leq t \leq 5$

- 26) If a rocket is propelled upward from ground level, its height in meters after  $t$  seconds is given by  $h = -9.8t^2 + 107.8t$ . During what interval of time will the rocket be higher than 274.4 m?

- A)  $4 < t < 7$                       B)  $0 < t < 4$                       C)  $7 < t < 8$                       D)  $8 < t < 11$

## 2.6 Building Quadratic Models from Verbal Descriptions and from Data

### 1 Build Quadratic Models from Verbal Descriptions

**MULTIPLE CHOICE.** Choose the one alternative that best completes the statement or answers the question.

**Solve the problem.**

- 1) A projectile is thrown upward so that its distance above the ground after  $t$  seconds is  $h = -11t^2 + 484t$ . After how many seconds does it reach its maximum height?  
A) 22 s                      B) 11 s                      C) 33 s                      D) 44 s
- 2) Alan is building a garden shaped like a rectangle with a semicircle attached to one short side along its diameter. The diameter of the semicircle is equal to the width of the short side of the rectangle. If he has 80 feet of fencing to go around the garden, what dimensions will give him the maximum area in the garden?  
A) width =  $\frac{160}{\pi + 4} \approx 22.4$ , length = 11.2                      B) width =  $\frac{80}{\pi + 4} \approx 11.2$ , length = 22.4  
C) width =  $\frac{160}{\pi + 8} \approx 14.4$ , length = 21.5                      D) width =  $\frac{160}{\pi + 4} \approx 22.4$ , length = 28.8
- 3) The number of mosquitoes  $M(x)$ , in millions, in a certain area depends on the June rainfall  $x$ , in inches:  $M(x) = 6x - x^2$ . What rainfall produces the maximum number of mosquitoes?  
A) 3 in.                      B) 0 in.                      C) 36 in.                      D) 6 in.
- 4) The manufacturer of a CD player has found that the revenue  $R$  (in dollars) is  $R(p) = -4p^2 + 1120p$ , when the unit price is  $p$  dollars. If the manufacturer sets the price  $p$  to maximize revenue, what is the maximum revenue to the nearest whole dollar?  
A) \$78,400                      B) \$156,800                      C) \$313,600                      D) \$627,200
- 5) A projectile is thrown upward so that its distance above the ground after  $t$  seconds is  $h = -10t^2 + 300t$ . After how many seconds does it reach its maximum height?  
A) 15 s                      B) 7 s                      C) 22.5 s                      D) 30 s
- 6) The owner of a video store has determined that the cost  $C$ , in dollars, of operating the store is approximately given by  $C(x) = 2x^2 - 30x + 600$ , where  $x$  is the number of videos rented daily. Find the lowest cost to the nearest dollar.  
A) \$488                      B) \$150                      C) \$375                      D) \$713
- 7) A developer wants to enclose a rectangular grassy lot that borders a city street for parking. If the developer has 304 feet of fencing and does not fence the side along the street, what is the largest area that can be enclosed?  
A) 11,552 ft<sup>2</sup>                      B) 23,104 ft<sup>2</sup>                      C) 5776 ft<sup>2</sup>                      D) 17,328 ft<sup>2</sup>





- 4) The number of housing starts in one beachside community remained fairly level until 1992 and then began to increase. The following data shows the number of housing starts since 1992 ( $x = 1$ ). Use a graphing calculator to plot a scatter diagram. What is the quadratic function of best fit?

Year, $x$	Housing Starts, $H$
1	200
2	205
3	210
4	240
5	245
6	230
7	220
8	210

A)  $H(x) = -2.679x^2 + 26.607x + 168.571$

B)  $H(x) = 2.679x^2 + 26.607x + 168.571$

C)  $H(x) = -2.679x^2 - 26.607x + 168.571$

D)  $H(x) = -2.679x^2 + 26.607x - 168.571$

- 5) The number of housing starts in one beachside community remained fairly level until 1992 and then began to increase. The following data shows the number of housing starts since 1992 ( $x = 1$ ). Use a graphing calculator to plot a scatter diagram. What is the quadratic function of best fit?

Year, $x$	Housing Starts, $H$
1	200
2	210
3	230
4	240
5	250
6	230
7	215
8	208

A)  $H(x) = -3.268x^2 + 30.494x + 168.982$

B)  $H(x) = 3.268x^2 + 30.494x + 168.982$

C)  $H(x) = -3.268x^2 - 30.494x + 168.982$

D)  $H(x) = -3.268x^2 + 30.494x - 168.982$

- 6) A small manufacturing firm collected the following data on advertising expenditures (in thousands of dollars) and total revenue (in thousands of dollars).

Advertising, $x$	Total Revenue, $R$
25	6430
28	6432
31	6434
32	6434
34	6434
39	6431
40	6432
45	6420

Find the quadratic function of best fit.

A)  $R(x) = -0.091x^2 + 5.95x + 6337$

B)  $R(x) = -0.024x^2 + 7.13x + 6209$

C)  $R(x) = -0.31x^2 + 2.63x + 6128$

D)  $R(x) = -0.015x^2 + 4.53x + 6123$

**SHORT ANSWER. Write the word or phrase that best completes each statement or answers the question.**

- 7) The following data represents the total revenue,  $R$  (in dollars), received from selling  $x$  bicycles at Tunney's Bicycle Shop. Using a graphing utility, find the quadratic function of best fit using coefficients rounded to the nearest hundredth.

Number of Bicycles, $x$	Total Revenue, $R$ (in dollars)
0	0
22	27,000
70	46,000
96	55,200
149	61,300
200	64,000
230	64,500
250	67,000

- 8) The following table shows the median number of hours of leisure time that Americans had each week in various years.

Year	1973	1980	1987	1993	1997
Median # of Leisure hrs per Week	26.2	19.2	16.6	18.8	19.5

Use  $x = 0$  to represent the year 1973. Using a graphing utility, determine the quadratic regression equation for the data given. What year corresponds to the time when Americans had the least time to spend on leisure?

## 2.7 Complex Zeros of a Quadratic Function

### 1 Find the Complex Zeros of a Quadratic Function

**MULTIPLE CHOICE. Choose the one alternative that best completes the statement or answers the question.**

**Find the complex zeros of the quadratic function.**

1)  $f(x) = x^2 - 16$

A)  $x = 4, x = -4$

B)  $x = 4$

C)  $x = -4$

D)  $x = 16$

2)  $G(x) = x^2 + 9$

A)  $x = -3i, x = 3i$

B)  $x = 3i$

C)  $x = 3$

D)  $x = -3, x = 3$

3)  $h(x) = x^2 - 4x + 13$

A)  $x = 2 + 3i, x = 2 - 3i$

C)  $x = 2 + 3i$

B)  $x = 2 - 9i, x = 2 + 9i$

D)  $x = 5, x = -1$

4)  $g(x) = 2x^2 - x + 4$

A)  $x = \frac{1}{4} \pm \frac{\sqrt{31}}{4}i$

B)  $x = 1 \pm \sqrt{31}$

C)  $x = \frac{1}{2} \pm \frac{\sqrt{31}}{2}i$

D)  $x = -\frac{1}{2}, x = \frac{1}{4}$

5)  $F(x) = x^2 - 12x + 40$

A)  $x = 6 \pm 2i$

B)  $x = 12 \pm 4i$

C)  $x = 8, x = 4$

D)  $x = -6 \pm 2i$

Without solving, determine the character of the solutions of the equation.

6)  $x^2 + 3x - 4 = 0$

- A) two unequal real solutions
- B) a repeated real solution
- C) two complex solutions that are conjugates of each other

7)  $f(x) = x^2 - 6x + 3$

- A) two unequal real solutions
- B) a repeated real solution
- C) two complex solutions that are conjugates of each other

8)  $x^2 - 8x + 16 = 0$

- A) a repeated real solution
- B) two unequal real solutions
- C) two complex solutions that are conjugates of each other

9)  $x^2 - 4x + 5 = 0$

- A) two complex solutions that are conjugates of each other
- B) two unequal real solutions
- C) a repeated real solution

10)  $x^2 + 5x - 7 = 0$

- A) two unequal real solutions
- B) a repeated real solution
- C) two complex solutions that are conjugates of each other

Solve the problem.

11)  $3 + 7i$  is a zero of a quadratic function with real coefficients. Find the other zero.

- A)  $3 - 7i$
- B)  $7i - 3$
- C) 10
- D)  $-3 - 7i$

## 2.8 Equations and Inequalities Involving the Absolute Value Function

### 1 Solve Absolute Value Equations

**MULTIPLE CHOICE.** Choose the one alternative that best completes the statement or answers the question.

Solve the equation.

1)  $|x| = 10$

- A)  $\{-10, 10\}$
- B)  $\{10\}$
- C)  $\{-10\}$
- D)  $\{100\}$

2)  $|x| = 0.69$

- A)  $\{-0.69, 0.69\}$
- B)  $\{0.69\}$
- C)  $\{-0.69\}$
- D)  $\{-1.44, 1.44\}$

3)  $|b + 3| + 9 = 11$

- A)  $\{-5, -1\}$
- B)  $\emptyset$
- C)  $\{-1\}$
- D)  $\{1, 5\}$

4)  $|7m + 6| = 8$

- A)  $\left\{-2, \frac{2}{7}\right\}$
- B)  $\emptyset$
- C)  $\left\{-\frac{2}{7}, 2\right\}$
- D)  $\left\{-\frac{7}{3}, \frac{1}{3}\right\}$

5)  $\left|\frac{1}{4}x - 7\right| = 2$

- A)  $\{20, 36\}$
- B)  $\{20\}$
- C)  $\{36\}$
- D)  $\{20, 36, 0\}$

6)  $|5x| = 0$

A)  $\{0\}$

B)  $\{0, 5\}$

C)  $\{-5, 5\}$

D)  $\{-5, 0\}$

7)  $|6x| = 4$

A)  $\left\{-\frac{2}{3}, \frac{2}{3}\right\}$

B)  $\left\{\frac{2}{3}\right\}$

C)  $\left\{-\frac{2}{3}\right\}$

D)  $\left\{-\frac{3}{2}, \frac{3}{2}\right\}$

8)  $|x + 5| - 4 = 12$

A)  $\{-21, 11\}$

B)  $\{13, 11\}$

C)  $\{-3, 11\}$

D)  $\{-11, 11\}$

9)  $|x^2 - 7x + 10| = 0$

A)  $\{5, 2\}$

B)  $\{-5, -2\}$

C)  $\{-10, -4\}$

D)  $\{10, 4\}$

10)  $|10x| = 2x^2$

A)  $\{0, 5, -5\}$

B)  $\{0, 5\}$

C)  $\{0, -5\}$

D) No real solutions

## 2 Solve Absolute Value Inequalities

**MULTIPLE CHOICE.** Choose the one alternative that best completes the statement or answers the question.

**Solve.**

1) If  $f(x) = |x|$  (solid line) and  $g(x) = 6$  (dashed line), find when  $f(x) = g(x)$  and when  $f(x) > g(x)$ .

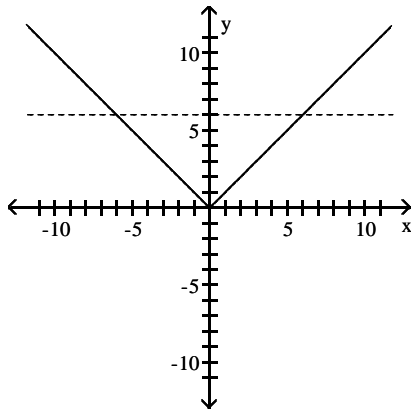

A)  $f(x) = g(x)$  when  $x = 6$  and  $x = -6$

$f(x) > g(x)$  when  $x < -6$  or  $x > 6$

C)  $f(x) = g(x)$  when  $x = 6$

$f(x) > g(x)$  when  $x < -6$

B)  $f(x) = g(x)$  when  $x = 6$  and  $x = -6$

$f(x) > g(x)$  when  $x > -6$  and  $x < 6$

D)  $f(x) = g(x)$  when  $x = -6$

$f(x) > g(x)$  when  $x > 6$

Solve the inequality. Express your answer using interval notation. Graph the solution set.

2)  $|x| < 4$

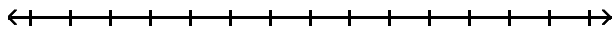

A)  $(-4, 4)$

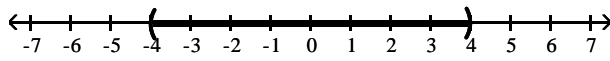

B)  $(-\infty, 4]$

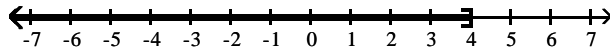

C)  $(-\infty, -4) \cup (4, \infty)$

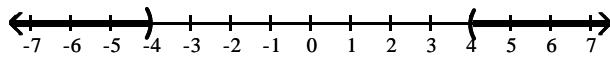

D)  $[-4, 4]$

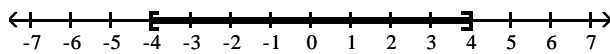

3)  $|x| > 2$

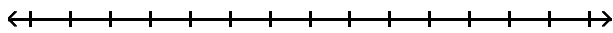

A)  $(-\infty, -2) \cup (2, \infty)$

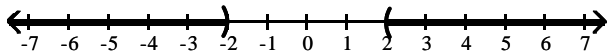

B)  $[2, \infty)$

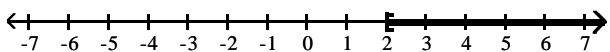

C)  $(-2, 2)$

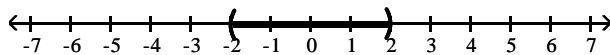

D)  $[-2, 2]$

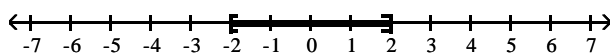

4)  $|x| > -3$

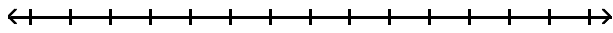

A)  $(-3, 3)$

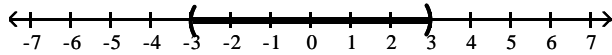

B)  $[-3, \infty)$

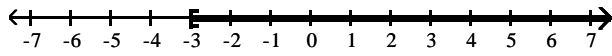

C)  $(-\infty, -3) \cup (3, \infty)$

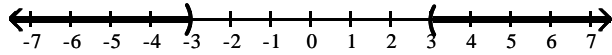

D)  $(-\infty, \infty)$

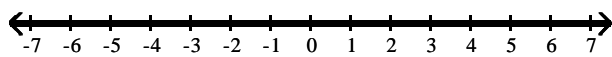

5)  $|x| < -2$

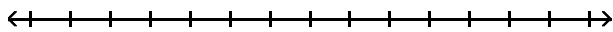

A)  $(-2, 2)$

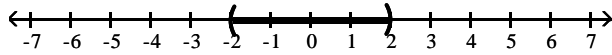

B)  $(-\infty, -2]$

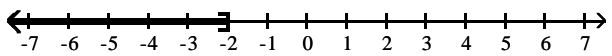

C)  $(-\infty, -2) \cup (2, \infty)$

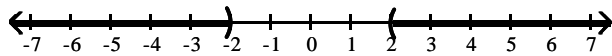

D)  $\emptyset$

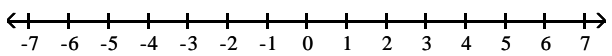

6)  $|3x| < 24$

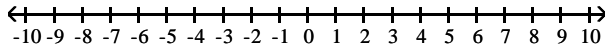

A)  $(-8, 8)$

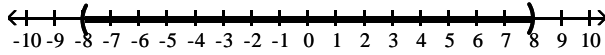

B)  $(-\infty, 8)$

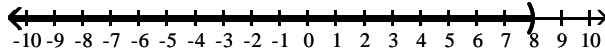

C)  $(-\infty, -8)$  or  $(8, \infty)$

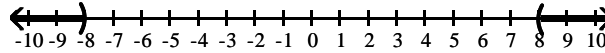

D)  $(-8, 8)$

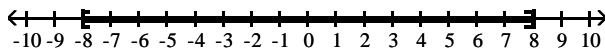

7)  $|7x| > 63$

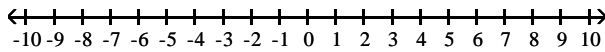

A)  $(-\infty, -9)$  or  $(9, \infty)$

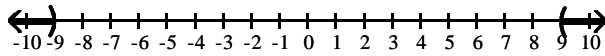

B)  $(9, \infty)$

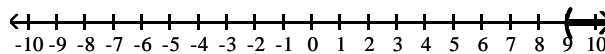

C)  $(-9, 9)$

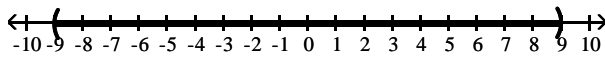

D)  $(-\infty, -9]$  or  $[9, \infty)$

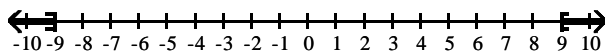

8)  $|x - 11| < 10$

A)  $(-9, 11)$

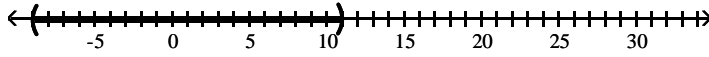

B)  $(-11, 9)$

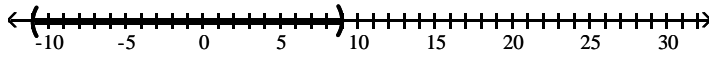

C)  $(-\infty, 11)$

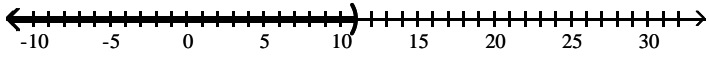

D)  $(-\infty, -9)$

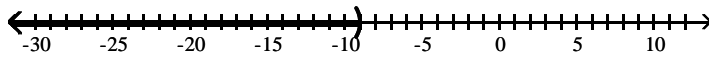

9)  $|x - 14| > 19$

A)  $(-\infty, -5) \cup (33, \infty)$

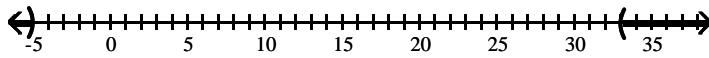

B)  $(-33, 5)$

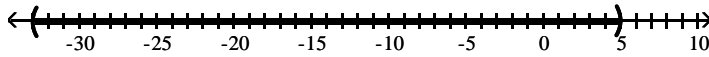

C)  $(-5, 33)$

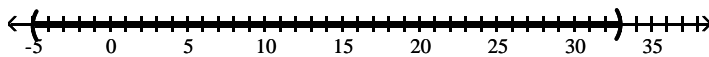

D)  $(33, \infty)$

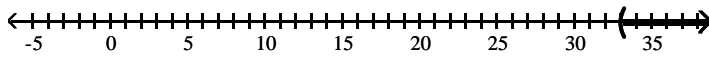



10)  $|3k - 4| \geq 3$

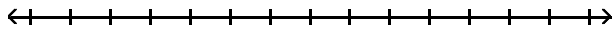

A)  $(-\infty, \frac{1}{3}] \cup [\frac{7}{3}, \infty)$

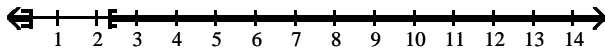

B)  $[\frac{1}{3}, \frac{7}{3}]$

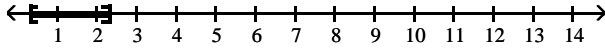

C)  $(\frac{1}{3}, \frac{7}{3})$

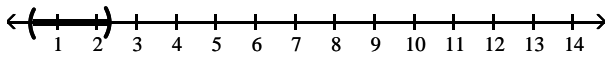

D)  $[\frac{7}{3}, \infty)$

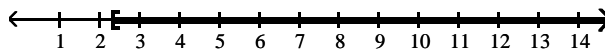

11)  $|6k + 3| \leq 8$

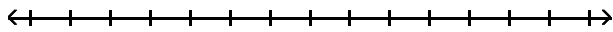

A)  $[-\frac{11}{6}, \frac{5}{6}]$

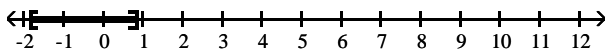

B)  $(-\infty, -\frac{11}{6}] \cup [\frac{5}{6}, \infty)$

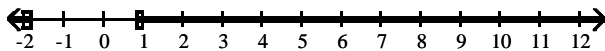

C)  $(-\frac{11}{6}, \frac{5}{6})$

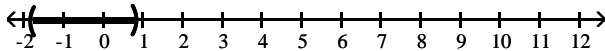

D)  $(-\infty, \frac{5}{6}]$

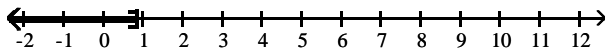

12)  $|x + 3| - 1 \leq 3$

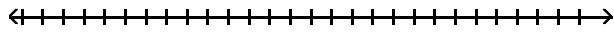

A)  $[-7, 1]$

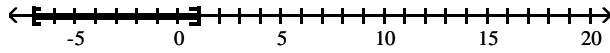

B)  $(-7, 1)$

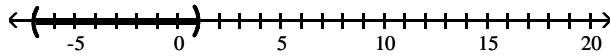

C)  $[-7, 3]$

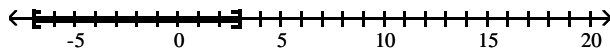

D)  $\emptyset$

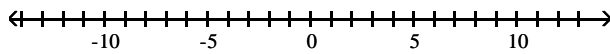

13)  $|x + 3| - 9 \geq -4$

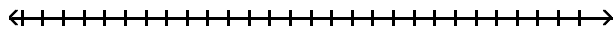

A)  $(-\infty, -8] \cup [2, \infty)$

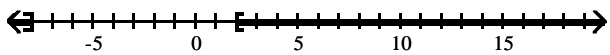

B)  $[-8, 2]$

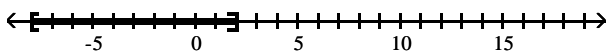

C)  $(-8, 2)$

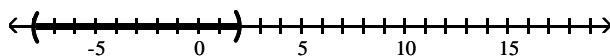

D)  $[2, \infty)$

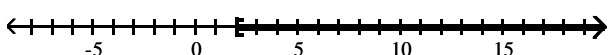

14)  $|2k + 6| - 3 > 4$

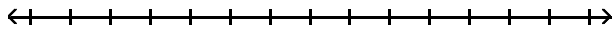

A)  $(-\infty, -\frac{13}{2}) \cup (\frac{1}{2}, \infty)$

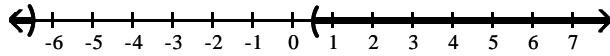

B)  $(-\frac{13}{2}, \frac{1}{2})$

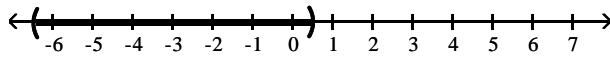

C)  $(-\infty, -\frac{13}{2}] \cup [\frac{1}{2}, \infty)$

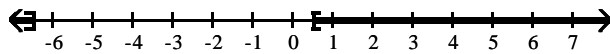

D)  $(\frac{1}{2}, \infty)$

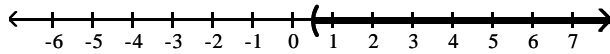

15)  $|2k + 8| + 4 < 7$

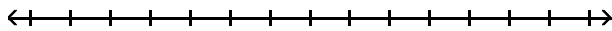

A)  $(-\frac{11}{2}, -\frac{5}{2})$

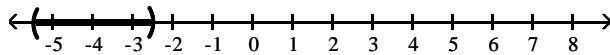

B)  $(-\infty, -\frac{11}{2}) \cup (-\frac{5}{2}, \infty)$

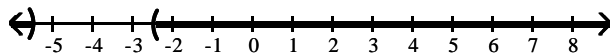

C)  $(-\infty, -\frac{11}{2})$

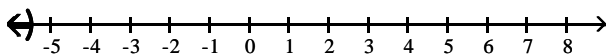

D)  $(-\infty, -\frac{5}{2})$

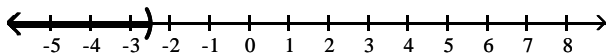

16)  $|x + 4| \geq 0$

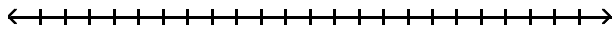

A) -4

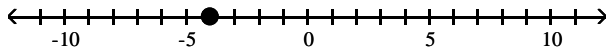

B)  $(-\infty, 4) \cup (4, \infty)$

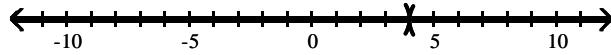

C)  $(-\infty, -4) \cup (-4, \infty)$

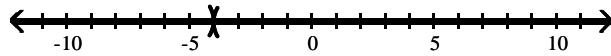

D)  $(-\infty, \infty)$

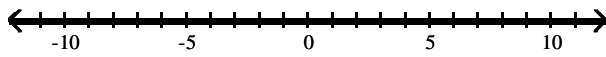

## Ch. 2 Linear and Quadratic Functions

### Answer Key

#### 2.1 Properties of Linear Functions and Linear Models

##### 1 Graph Linear Functions

- 1) A
- 2) A
- 3) A
- 4) A
- 5) A
- 6) A
- 7) A
- 8) A
- 9) A
- 10) A
- 11) A
- 12) A
- 13) A
- 14) A
- 15) A
- 16) A

##### 2 Use Average Rate of Change to Identify Linear Functions

- 1) A
- 2) A
- 3) A
- 4) A
- 5) A
- 6) A

##### 3 Determine Whether a Linear Function is Increasing, Decreasing, or Constant

- 1) A
- 2) A
- 3) A
- 4) A
- 5) A
- 6) A
- 7) A
- 8) A

##### 4 Find the Zero of a Linear Function

- 1) A
- 2) A
- 3) A
- 4) A
- 5) A
- 6) A
- 7) A
- 8) A
- 9) A
- 10) A
- 11) A
- 12) A
- 13) A

##### 5 Build Linear Models from Verbal Descriptions

- 1) A

- 2) A
- 3) A
- 4) A
- 5) A
- 6) A
- 7) A
- 8) A
- 9) A
- 10) A
- 11) A
- 12) A
- 13) A
- 14) A

## 2.2 Building Linear Models from Data

### 1 Draw and Interpret Scatter Diagrams

- 1) A
- 2) A
- 3) A
- 4)

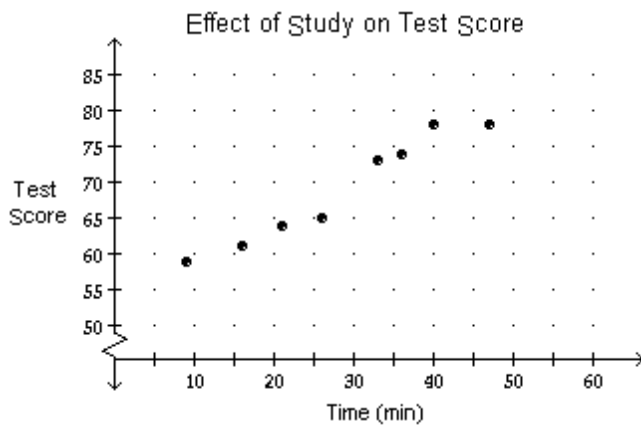

More time spent studying may increase test scores.

### 5) Latitude (degrees)

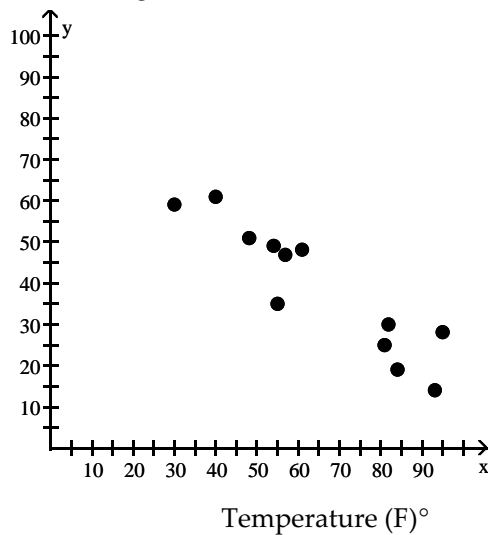

As the latitude increases, the one-day temperatures decrease.

- 6) A

- 7) A
- 8) A

**2 Distinguish between Linear and Nonlinear Relations**

- 1) A
- 2) A
- 3) A
- 4) A
- 5) A
- 6) A
- 7) A

**3 Use a Graphing Utility to Find the Line of Best Fit**

- 1) A
- 2) A
- 3) A
- 4) A
- 5) A
- 6) A
- 7) A
- 8) A
- 9) A
- 10) A
- 11) B
- 12) A
- 13) A
- 14) A
- 15) A

16) Latitude (degrees)

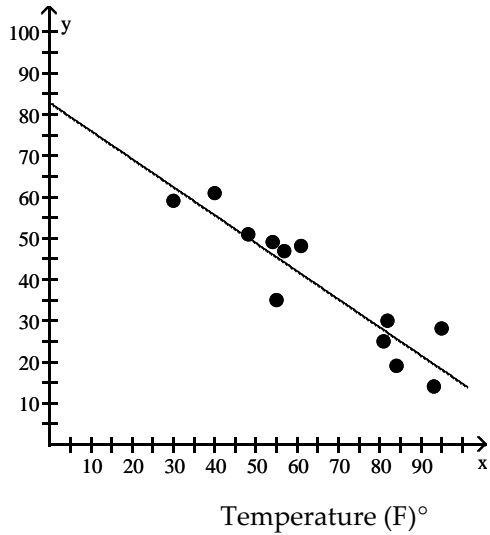

Line of best fit =  $-0.68x + 82.91$

- 17) A
- 18) A
- 19) A
- 20) A
- 21) \$347.29
- 22) The slope is 12.75 which means that the amount Tom saves increases \$12.75 each month.
- 23) 53.56
- 24) The slope is about  $-0.12616$  which means that the winning time is decreasing by 0.12616 of a second each year.

25) 1840

26) The slope is about 206.1 which means that the number of employees is increasing by about 206 employees each year.

## 2.3 Quadratic Functions and Their Zeros

### 1 Find the Zeros of a Quadratic Function by Factoring

- 1) A
- 2) A
- 3) A
- 4) A
- 5) A
- 6) A
- 7) A
- 8) A
- 9) A
- 10) A
- 11) A

### 2 Find the Zeros of a Quadratic Function Using the Square Root Method

- 1) A
- 2) A
- 3) A
- 4) A
- 5) A

### 3 Find the Zeros of a Quadratic Function by Completing the Square

- 1) A
- 2) A
- 3) A
- 4) A
- 5) A
- 6) A

### 4 Find the Zeros of a Quadratic Function Using the Quadratic Formula

- 1) A
- 2) A
- 3) A
- 4) A
- 5) A
- 6) D

### 5 Find the Point of Intersection of Two Functions

- 1) A
- 2) A
- 3) A
- 4) A

### 6 Solve Equations That Are Quadratic in Form

- 1) A
- 2) A
- 3) A
- 4) A
- 5) A
- 6) A
- 7) A
- 8) A
- 9) A
- 10) A



- 11) A
- 12) A
- 13) A

## 2.4 Properties of Quadratic Functions

### 1 Graph a Quadratic Function Using Transformations

- 1) A
- 2) A
- 3) A
- 4) A
- 5) A
- 6) A
- 7) A
- 8) A
- 9) A
- 10) A
- 11) A
- 12) A
- 13) A
- 14) A
- 15) A

### 2 Identify the Vertex and Axis of Symmetry of a Quadratic Function

- 1) A
- 2) A
- 3) A
- 4) A
- 5) A
- 6) A
- 7) A
- 8) A
- 9) A
- 10) A

### 3 Graph a Quadratic Function Using Its Vertex, Axis, and Intercepts

- 1) A
- 2) A
- 3) A
- 4) A
- 5) A
- 6) A
- 7) A
- 8) A
- 9) A
- 10) A
- 11) A
- 12) A
- 13) A
- 14) A
- 15) A
- 16) A
- 17) A
- 18) A
- 19) A
- 20) A

- 21) A
- 22) A
- 23) A
- 24) A
- 25) A
- 26) A

**4 Find a Quadratic Function Given Its Vertex and One Other Point**

- 1) A
- 2) A

**5 Find the Maximum or Minimum Value of a Quadratic Function**

- 1) A
- 2) A
- 3) A
- 4) A
- 5) A
- 6) A
- 7) A
- 8) A
- 9) A
- 10) A
- 11) A
- 12) A
- 13) A
- 14) A
- 15) A
- 16) A
- 17) A
- 18) A
- 19) A
- 20) A
- 21) A
- 22) A
- 23) A
- 24) A
- 25) The height is approximately 17 ft.
- 26) A
- 27) A

**2.5 Inequalities Involving Quadratic Functions**

**1 Solve Inequalities Involving a Quadratic Function**

- 1) A
- 2) A
- 3) A
- 4) A
- 5) A
- 6) A
- 7) A
- 8) A
- 9) A
- 10) A
- 11) A
- 12) A
- 13) B

- 14) A
- 15) A
- 16) A
- 17) A
- 18) A
- 19) A
- 20) A
- 21) A
- 22) A
- 23) A
- 24) A
- 25) A
- 26) A

## 2.6 Building Quadratic Models from Verbal Descriptions and from Data

### 1 Build Quadratic Models from Verbal Descriptions

- 1) A
- 2) A
- 3) A
- 4) A
- 5) A
- 6) A
- 7) A
- 8) A

### 2 Build Quadratic Models from Data

- 1) A
- 2) A
- 3) A
- 4) A
- 5) A
- 6) A
- 7)  $R(x) = -1.65x^2 + 634.42x + 7089.93$
- 8)  $M(x) = 0.04x^2 - 1.21x + 26.03$ ; 1988

## 2.7 Complex Zeros of a Quadratic Function

### 1 Find the Complex Zeros of a Quadratic Function

- 1) A
- 2) A
- 3) A
- 4) A
- 5) A
- 6) A
- 7) A
- 8) A
- 9) A
- 10) A
- 11) A

## 2.8 Equations and Inequalities Involving the Absolute Value Function

### 1 Solve Absolute Value Equations

- 1) A
- 2) A
- 3) A
- 4) A
- 5) A

- 6) A
- 7) A
- 8) A
- 9) A
- 10) A

**2 Solve Absolute Value Inequalities**

- 1) A
- 2) A
- 3) A
- 4) D
- 5) D
- 6) A
- 7) A
- 8) A
- 9) A
- 10) A
- 11) A
- 12) A
- 13) A
- 14) A
- 15) A
- 16) D