

Chapter 2

Graphs

Section 2.1

1. $|5 - (-3)| = |8| = 8$

2. $\sqrt{3^2 + 4^2} = \sqrt{25} = 5$

3. $11^2 + 60^2 = 121 + 3600 = 3721 = 61^2$

Since the sum of the squares of two of the sides of the triangle equals the square of the third side, the triangle is a right triangle.

4. $(0, 0)$

5. $\frac{1}{2}bh$

6. true

7. midpoint

8. False; the distance between two points is never negative.

9. True; $M = \left(\frac{x_1 + x_2}{2}, \frac{y_1 + y_2}{2}\right)$

10. a

11. $d(P_1, P_2) = \sqrt{(2-0)^2 + (1-0)^2}$
 $= \sqrt{2^2 + 1^2} = \sqrt{4+1} = \sqrt{5}$

12. $d(P_1, P_2) = \sqrt{(-2-0)^2 + (1-0)^2}$
 $= \sqrt{(-2)^2 + 1^2} = \sqrt{4+1} = \sqrt{5}$

13. $d(P_1, P_2) = \sqrt{(-2-1)^2 + (2-1)^2}$
 $= \sqrt{(-3)^2 + 1^2} = \sqrt{9+1} = \sqrt{10}$

14. $d(P_1, P_2) = \sqrt{(2-(-1))^2 + (2-1)^2}$
 $= \sqrt{3^2 + 1^2} = \sqrt{9+1} = \sqrt{10}$

15. $d(P_1, P_2) = \sqrt{(5-3)^2 + (4-(-4))^2}$
 $= \sqrt{2^2 + (8)^2} = \sqrt{4+64} = \sqrt{68} = 2\sqrt{17}$

16. $d(P_1, P_2) = \sqrt{(2-(-1))^2 + (4-0)^2}$
 $= \sqrt{(3)^2 + 4^2} = \sqrt{9+16} = \sqrt{25} = 5$

17. $d(P_1, P_2) = \sqrt{(4-(-7))^2 + (0-3)^2}$
 $= \sqrt{11^2 + (-3)^2} = \sqrt{121+9} = \sqrt{130}$

18. $d(P_1, P_2) = \sqrt{(4-2)^2 + (2-(-3))^2}$
 $= \sqrt{2^2 + 5^2} = \sqrt{4+25} = \sqrt{29}$

19. $d(P_1, P_2) = \sqrt{(6-5)^2 + (1-(-2))^2}$
 $= \sqrt{1^2 + 3^2} = \sqrt{1+9} = \sqrt{10}$

20. $d(P_1, P_2) = \sqrt{(6-(-4))^2 + (2-(-3))^2}$
 $= \sqrt{10^2 + 5^2} = \sqrt{100+25}$
 $= \sqrt{125} = 5\sqrt{5}$

21. $d(P_1, P_2) = \sqrt{(2.3-(-0.2))^2 + (1.1-(0.3))^2}$
 $= \sqrt{2.5^2 + 0.8^2} = \sqrt{6.25+0.64}$
 $= \sqrt{6.89} \approx 2.62$

22. $d(P_1, P_2) = \sqrt{(-0.3-1.2)^2 + (1.1-2.3)^2}$
 $= \sqrt{(-1.5)^2 + (-1.2)^2} = \sqrt{2.25+1.44}$
 $= \sqrt{3.69} \approx 1.92$

23. $d(P_1, P_2) = \sqrt{(0-a)^2 + (0-b)^2}$
 $= \sqrt{(-a)^2 + (-b)^2} = \sqrt{a^2 + b^2}$

24. $d(P_1, P_2) = \sqrt{(0-a)^2 + (0-a)^2}$
 $= \sqrt{(-a)^2 + (-a)^2}$
 $= \sqrt{a^2 + a^2} = \sqrt{2a^2} = |a|\sqrt{2}$

Section 2.1: The Distance and Midpoint Formulas

25. $A = (-2, 5)$, $B = (1, 3)$, $C = (-1, 0)$

$$d(A, B) = \sqrt{(1 - (-2))^2 + (3 - 5)^2}$$

$$= \sqrt{3^2 + (-2)^2} = \sqrt{9 + 4} = \sqrt{13}$$

$$d(B, C) = \sqrt{(-1 - 1)^2 + (0 - 3)^2}$$

$$= \sqrt{(-2)^2 + (-3)^2} = \sqrt{4 + 9} = \sqrt{13}$$

$$d(A, C) = \sqrt{(-1 - (-2))^2 + (0 - 5)^2}$$

$$= \sqrt{1^2 + (-5)^2} = \sqrt{1 + 25} = \sqrt{26}$$

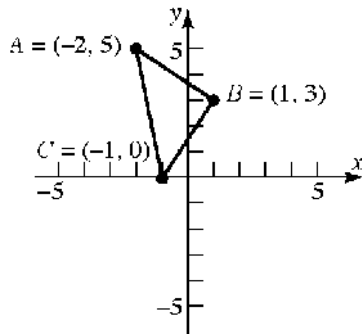

Verifying that $\triangle ABC$ is a right triangle by the Pythagorean Theorem:

$$[d(A, B)]^2 + [d(B, C)]^2 = [d(A, C)]^2$$

$$(\sqrt{13})^2 + (\sqrt{13})^2 = (\sqrt{26})^2$$

$$13 + 13 = 26$$

$$26 = 26$$

The area of a triangle is $A = \frac{1}{2} \cdot bh$. In this problem,

$$A = \frac{1}{2} \cdot [d(A, B)] \cdot [d(B, C)]$$

$$= \frac{1}{2} \cdot \sqrt{13} \cdot \sqrt{13} = \frac{1}{2} \cdot 13$$

$$= \frac{13}{2} \text{ square units}$$

26. $A = (-2, 5)$, $B = (12, 3)$, $C = (10, -11)$

$$d(A, B) = \sqrt{(12 - (-2))^2 + (3 - 5)^2}$$

$$= \sqrt{14^2 + (-2)^2}$$

$$= \sqrt{196 + 4} = \sqrt{200}$$

$$= 10\sqrt{2}$$

$$d(B, C) = \sqrt{(10 - 12)^2 + (-11 - 3)^2}$$

$$= \sqrt{(-2)^2 + (-14)^2}$$

$$= \sqrt{4 + 196} = \sqrt{200}$$

$$= 10\sqrt{2}$$

$$d(A, C) = \sqrt{(10 - (-2))^2 + (-11 - 5)^2}$$

$$= \sqrt{12^2 + (-16)^2}$$

$$= \sqrt{144 + 256} = \sqrt{400}$$

$$= 20$$

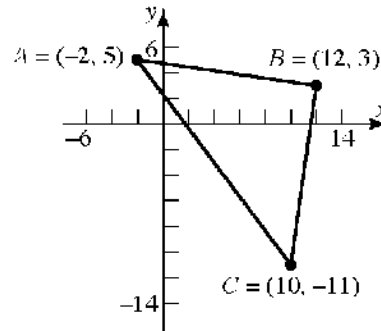

Verifying that $\triangle ABC$ is a right triangle by the Pythagorean Theorem:

$$[d(A, B)]^2 + [d(B, C)]^2 = [d(A, C)]^2$$

$$(10\sqrt{2})^2 + (10\sqrt{2})^2 = (20)^2$$

$$200 + 200 = 400$$

$$400 = 400$$

The area of a triangle is $A = \frac{1}{2}bh$. In this problem,

$$A = \frac{1}{2} \cdot [d(A, B)] \cdot [d(B, C)]$$

$$= \frac{1}{2} \cdot 10\sqrt{2} \cdot 10\sqrt{2}$$

$$= \frac{1}{2} \cdot 100 \cdot 2 = 100 \text{ square units}$$

Chapter 2: Graphs

27. $A = (-5, 3)$, $B = (6, 0)$, $C = (5, 5)$

$$\begin{aligned} d(A, B) &= \sqrt{(6 - (-5))^2 + (0 - 3)^2} \\ &= \sqrt{11^2 + (-3)^2} = \sqrt{121 + 9} \\ &= \sqrt{130} \end{aligned}$$

$$\begin{aligned} d(B, C) &= \sqrt{(5 - 6)^2 + (5 - 0)^2} \\ &= \sqrt{(-1)^2 + 5^2} = \sqrt{1 + 25} \\ &= \sqrt{26} \end{aligned}$$

$$\begin{aligned} d(A, C) &= \sqrt{(5 - (-5))^2 + (5 - 3)^2} \\ &= \sqrt{10^2 + 2^2} = \sqrt{100 + 4} \\ &= \sqrt{104} \\ &= 2\sqrt{26} \end{aligned}$$

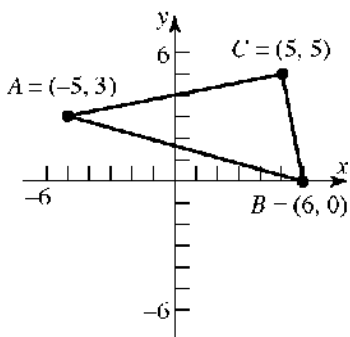

Verifying that $\triangle ABC$ is a right triangle by the Pythagorean Theorem:

$$\begin{aligned} [d(A, C)]^2 + [d(B, C)]^2 &= [d(A, B)]^2 \\ (\sqrt{104})^2 + (\sqrt{26})^2 &= (\sqrt{130})^2 \\ 104 + 26 &= 130 \\ 130 &= 130 \end{aligned}$$

The area of a triangle is $A = \frac{1}{2}bh$. In this problem,

$$\begin{aligned} A &= \frac{1}{2} \cdot [d(A, C)] \cdot [d(B, C)] \\ &= \frac{1}{2} \cdot \sqrt{104} \cdot \sqrt{26} \\ &= \frac{1}{2} \cdot 2\sqrt{26} \cdot \sqrt{26} \\ &= \frac{1}{2} \cdot 2 \cdot 26 \\ &= 26 \text{ square units} \end{aligned}$$

28. $A = (-6, 3)$, $B = (3, -5)$, $C = (-1, 5)$

$$\begin{aligned} d(A, B) &= \sqrt{(3 - (-6))^2 + (-5 - 3)^2} \\ &= \sqrt{9^2 + (-8)^2} = \sqrt{81 + 64} \\ &= \sqrt{145} \end{aligned}$$

$$\begin{aligned} d(B, C) &= \sqrt{(-1 - 3)^2 + (5 - (-5))^2} \\ &= \sqrt{(-4)^2 + 10^2} = \sqrt{16 + 100} \\ &= \sqrt{116} = 2\sqrt{29} \end{aligned}$$

$$\begin{aligned} d(A, C) &= \sqrt{(-1 - (-6))^2 + (5 - 3)^2} \\ &= \sqrt{5^2 + 2^2} = \sqrt{25 + 4} \\ &= \sqrt{29} \end{aligned}$$

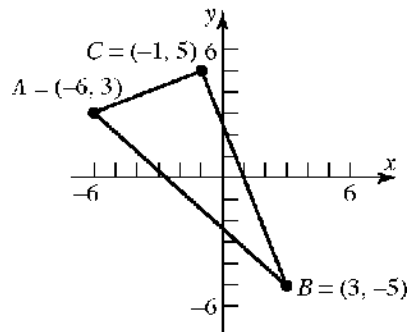

Verifying that $\triangle ABC$ is a right triangle by the Pythagorean Theorem:

$$\begin{aligned} [d(A, C)]^2 + [d(B, C)]^2 &= [d(A, B)]^2 \\ (\sqrt{29})^2 + (2\sqrt{29})^2 &= (\sqrt{145})^2 \\ 29 + 4 \cdot 29 &= 145 \\ 29 + 116 &= 145 \\ 145 &= 145 \end{aligned}$$

The area of a triangle is $A = \frac{1}{2}bh$. In this problem,

$$\begin{aligned} A &= \frac{1}{2} \cdot [d(A, C)] \cdot [d(B, C)] \\ &= \frac{1}{2} \cdot \sqrt{29} \cdot 2\sqrt{29} \\ &= \frac{1}{2} \cdot 2 \cdot 29 \\ &= 29 \text{ square units} \end{aligned}$$

Section 2.1: The Distance and Midpoint Formulas

29. $A = (4, -3), B = (0, -3), C = (4, 2)$

$$\begin{aligned} d(A, B) &= \sqrt{(0-4)^2 + (-3-(-3))^2} \\ &= \sqrt{(-4)^2 + 0^2} = \sqrt{16+0} \\ &= \sqrt{16} \\ &= 4 \end{aligned}$$

$$\begin{aligned} d(B, C) &= \sqrt{(4-0)^2 + (2-(-3))^2} \\ &= \sqrt{4^2 + 5^2} = \sqrt{16+25} \\ &= \sqrt{41} \end{aligned}$$

$$\begin{aligned} d(A, C) &= \sqrt{(4-4)^2 + (2-(-3))^2} \\ &= \sqrt{0^2 + 5^2} = \sqrt{0+25} \\ &= \sqrt{25} \\ &= 5 \end{aligned}$$

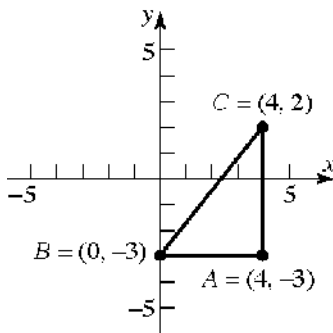

Verifying that $\triangle ABC$ is a right triangle by the Pythagorean Theorem:

$$\begin{aligned} [d(A, B)]^2 + [d(A, C)]^2 &= [d(B, C)]^2 \\ 4^2 + 5^2 &= (\sqrt{41})^2 \\ 16 + 25 &= 41 \\ 41 &= 41 \end{aligned}$$

The area of a triangle is $A = \frac{1}{2}bh$. In this problem,

$$\begin{aligned} A &= \frac{1}{2} \cdot [d(A, B)] \cdot [d(A, C)] \\ &= \frac{1}{2} \cdot 4 \cdot 5 \\ &= 10 \text{ square units} \end{aligned}$$

30. $A = (4, -3), B = (4, 1), C = (2, 1)$

$$\begin{aligned} d(A, B) &= \sqrt{(4-4)^2 + (1-(-3))^2} \\ &= \sqrt{0^2 + 4^2} \\ &= \sqrt{0+16} \\ &= \sqrt{16} \\ &= 4 \end{aligned}$$

$$\begin{aligned} d(B, C) &= \sqrt{(2-4)^2 + (1-1)^2} \\ &= \sqrt{(-2)^2 + 0^2} = \sqrt{4+0} \\ &= \sqrt{4} \\ &= 2 \end{aligned}$$

$$\begin{aligned} d(A, C) &= \sqrt{(2-4)^2 + (1-(-3))^2} \\ &= \sqrt{(-2)^2 + 4^2} = \sqrt{4+16} \\ &= \sqrt{20} \\ &= 2\sqrt{5} \end{aligned}$$

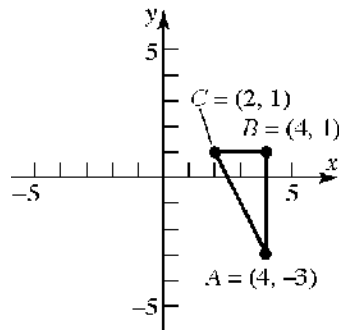

Verifying that $\triangle ABC$ is a right triangle by the Pythagorean Theorem:

$$\begin{aligned} [d(A, B)]^2 + [d(B, C)]^2 &= [d(A, C)]^2 \\ 4^2 + 2^2 &= (2\sqrt{5})^2 \\ 16 + 4 &= 20 \\ 20 &= 20 \end{aligned}$$

The area of a triangle is $A = \frac{1}{2}bh$. In this problem,

$$\begin{aligned} A &= \frac{1}{2} \cdot [d(A, B)] \cdot [d(B, C)] \\ &= \frac{1}{2} \cdot 4 \cdot 2 \\ &= 4 \text{ square units} \end{aligned}$$

Chapter 2: Graphs

31. The coordinates of the midpoint are:

$$\begin{aligned}(x, y) &= \left(\frac{x_1 + x_2}{2}, \frac{y_1 + y_2}{2} \right) \\ &= \left(\frac{3+5}{2}, \frac{-4+4}{2} \right) \\ &= \left(\frac{8}{2}, \frac{0}{2} \right) \\ &= (4, 0)\end{aligned}$$

32. The coordinates of the midpoint are:

$$\begin{aligned}(x, y) &= \left(\frac{x_1 + x_2}{2}, \frac{y_1 + y_2}{2} \right) \\ &= \left(\frac{-2+2}{2}, \frac{0+4}{2} \right) \\ &= \left(\frac{0}{2}, \frac{4}{2} \right) \\ &= (0, 2)\end{aligned}$$

33. The coordinates of the midpoint are:

$$\begin{aligned}(x, y) &= \left(\frac{x_1 + x_2}{2}, \frac{y_1 + y_2}{2} \right) \\ &= \left(\frac{-1+8}{2}, \frac{4+0}{2} \right) \\ &= \left(\frac{7}{2}, \frac{4}{2} \right) \\ &= \left(\frac{7}{2}, 2 \right)\end{aligned}$$

34. The coordinates of the midpoint are:

$$\begin{aligned}(x, y) &= \left(\frac{x_1 + x_2}{2}, \frac{y_1 + y_2}{2} \right) \\ &= \left(\frac{2+4}{2}, \frac{-3+2}{2} \right) \\ &= \left(\frac{6}{2}, \frac{-1}{2} \right) \\ &= \left(3, -\frac{1}{2} \right)\end{aligned}$$

35. The coordinates of the midpoint are:

$$\begin{aligned}(x, y) &= \left(\frac{x_1 + x_2}{2}, \frac{y_1 + y_2}{2} \right) \\ &= \left(\frac{7+9}{2}, \frac{-5+1}{2} \right) \\ &= \left(\frac{16}{2}, \frac{-4}{2} \right) \\ &= (8, -2)\end{aligned}$$

36. The coordinates of the midpoint are:

$$\begin{aligned}(x, y) &= \left(\frac{x_1 + x_2}{2}, \frac{y_1 + y_2}{2} \right) \\ &= \left(\frac{-4+2}{2}, \frac{-3+2}{2} \right) \\ &= \left(\frac{-2}{2}, \frac{-1}{2} \right) \\ &= \left(-1, -\frac{1}{2} \right)\end{aligned}$$

37. The coordinates of the midpoint are:

$$\begin{aligned}(x, y) &= \left(\frac{x_1 + x_2}{2}, \frac{y_1 + y_2}{2} \right) \\ &= \left(\frac{a+0}{2}, \frac{b+0}{2} \right) \\ &= \left(\frac{a}{2}, \frac{b}{2} \right)\end{aligned}$$

38. The coordinates of the midpoint are:

$$\begin{aligned}(x, y) &= \left(\frac{x_1 + x_2}{2}, \frac{y_1 + y_2}{2} \right) \\ &= \left(\frac{a+0}{2}, \frac{a+0}{2} \right) \\ &= \left(\frac{a}{2}, \frac{a}{2} \right)\end{aligned}$$

39. $P_1 = (1, 3); P_2 = (5, 15)$

$$\begin{aligned}d(P_1, P_2) &= \sqrt{(5-1)^2 + (15-3)^2} \\ &= \sqrt{(4)^2 + (12)^2} \\ &= \sqrt{16+144} \\ &= \sqrt{160} = 4\sqrt{10}\end{aligned}$$

The coordinates of the midpoint are:

$$\begin{aligned}(x, y) &= \left(\frac{x_1 + x_2}{2}, \frac{y_1 + y_2}{2} \right) \\ &= \left(\frac{1+5}{2}, \frac{3+15}{2} \right) \\ &= \left(\frac{6}{2}, \frac{18}{2} \right) \\ &= (3, 9)\end{aligned}$$

Section 2.1: The Distance and Midpoint Formulas

40. $P_1 = (-8, -4); P_2 = (2, 3)$

$$\begin{aligned} d(P_1, P_2) &= \sqrt{(2 - (-8))^2 + (3 - (-4))^2} \\ &= \sqrt{(10)^2 + (7)^2} \\ &= \sqrt{100 + 49} \\ &= \sqrt{149} \end{aligned}$$

The coordinates of the midpoint are:

$$\begin{aligned} (x, y) &= \left(\frac{x_1 + x_2}{2}, \frac{y_1 + y_2}{2} \right) \\ &= \left(\frac{-8 + 2}{2}, \frac{-4 + 3}{2} \right) \\ &= \left(\frac{-6}{2}, \frac{-1}{2} \right) \\ &= \left(-3, -\frac{1}{2} \right) \end{aligned}$$

41. $P_1 = (-4, 6); P_2 = (4, -8)$

$$\begin{aligned} d(P_1, P_2) &= \sqrt{(4 - (-4))^2 + (-8 - 6)^2} \\ &= \sqrt{(8)^2 + (-14)^2} \\ &= \sqrt{64 + 196} \\ &= \sqrt{260} = 2\sqrt{65} \end{aligned}$$

The coordinates of the midpoint are:

$$\begin{aligned} (x, y) &= \left(\frac{x_1 + x_2}{2}, \frac{y_1 + y_2}{2} \right) \\ &= \left(\frac{-4 + 4}{2}, \frac{6 + (-8)}{2} \right) \\ &= \left(\frac{0}{2}, \frac{-2}{2} \right) \\ &= (0, -1) \end{aligned}$$

42. $P_1 = (0, 6); P_2 = (3, -8)$

$$\begin{aligned} d(P_1, P_2) &= \sqrt{(3 - 0)^2 + (-8 - 6)^2} \\ &= \sqrt{(3)^2 + (-14)^2} \\ &= \sqrt{9 + 196} \\ &= \sqrt{205} \end{aligned}$$

The coordinates of the midpoint are:

$$\begin{aligned} (x, y) &= \left(\frac{x_1 + x_2}{2}, \frac{y_1 + y_2}{2} \right) \\ &= \left(\frac{0 + 3}{2}, \frac{6 + (-8)}{2} \right) \\ &= \left(\frac{3}{2}, \frac{-2}{2} \right) \\ &= \left(\frac{3}{2}, -1 \right) \end{aligned}$$

43. a. If we use a right triangle to solve the problem, we know the hypotenuse is 13 units in length. One of the legs of the triangle will be $2+3=5$. Thus the other leg will be:

$$\begin{aligned} 5^2 + b^2 &= 13^2 \\ 25 + b^2 &= 169 \\ b^2 &= 144 \\ b &= 12 \end{aligned}$$

Thus the coordinates will have an y value of $-1-12 = -13$ and $-1+12 = 11$. So the points are $(3, 11)$ and $(3, -13)$.

- b. Consider points of the form $(3, y)$ that are a distance of 13 units from the point $(-2, -1)$.

$$\begin{aligned} d &= \sqrt{(x_2 - x_1)^2 + (y_2 - y_1)^2} \\ &= \sqrt{(3 - (-2))^2 + (-1 - y)^2} \\ &= \sqrt{(5)^2 + (-1 - y)^2} \\ &= \sqrt{25 + 1 + 2y + y^2} \\ &= \sqrt{y^2 + 2y + 26} \\ 13 &= \sqrt{y^2 + 2y + 26} \end{aligned}$$

$$13^2 = (\sqrt{y^2 + 2y + 26})^2$$

$$169 = y^2 + 2y + 26$$

$$0 = y^2 + 2y - 143$$

$$0 = (y - 11)(y + 13)$$

$$y - 11 = 0 \quad \text{or} \quad y + 13 = 0$$

$$y = 11 \quad \quad \quad y = -13$$

Thus, the points $(3, 11)$ and $(3, -13)$ are a distance of 13 units from the point $(-2, -1)$.

Chapter 2: Graphs

- 44. a.** If we use a right triangle to solve the problem, we know the hypotenuse is 17 units in length. One of the legs of the triangle will be $2+6=8$. Thus the other leg will be:

$$8^2 + b^2 = 17^2$$

$$64 + b^2 = 289$$

$$b^2 = 225$$

$$b = 15$$

Thus the coordinates will have an x value of $1-15 = -14$ and $1+15 = 16$. So the points are $(-14, -6)$ and $(16, -6)$.

- b.** Consider points of the form $(x, -6)$ that are a distance of 17 units from the point $(1, 2)$.

$$d = \sqrt{(x_2 - x_1)^2 + (y_2 - y_1)^2}$$

$$= \sqrt{(1-x)^2 + (2-(-6))^2}$$

$$= \sqrt{x^2 - 2x + 1 + (8)^2}$$

$$= \sqrt{x^2 - 2x + 1 + 64}$$

$$= \sqrt{x^2 - 2x + 65}$$

$$17 = \sqrt{x^2 - 2x + 65}$$

$$17^2 = (\sqrt{x^2 - 2x + 65})^2$$

$$289 = x^2 - 2x + 65$$

$$0 = x^2 - 2x - 224$$

$$0 = (x+14)(x-16)$$

$$x+14 = 0 \quad \text{or} \quad x-16 = 0$$

$$x = -14 \quad \quad \quad x = 16$$

Thus, the points $(-14, -6)$ and $(16, -6)$ are a distance of 17 units from the point $(1, 2)$.

- 45.** Points on the x -axis have a y -coordinate of 0. Thus, we consider points of the form $(x, 0)$ that are a distance of 6 units from the point $(4, -3)$.

$$d = \sqrt{(x_2 - x_1)^2 + (y_2 - y_1)^2}$$

$$= \sqrt{(4-x)^2 + (-3-0)^2}$$

$$= \sqrt{16 - 8x + x^2 + (-3)^2}$$

$$= \sqrt{16 - 8x + x^2 + 9}$$

$$= \sqrt{x^2 - 8x + 25}$$

$$6 = \sqrt{x^2 - 8x + 25}$$

$$6^2 = (\sqrt{x^2 - 8x + 25})^2$$

$$36 = x^2 - 8x + 25$$

$$0 = x^2 - 8x - 11$$

$$x = \frac{-(-8) \pm \sqrt{(-8)^2 - 4(1)(-11)}}{2(1)}$$

$$= \frac{8 \pm \sqrt{64 + 44}}{2} = \frac{8 \pm \sqrt{108}}{2}$$

$$= \frac{8 \pm 6\sqrt{3}}{2} = 4 \pm 3\sqrt{3}$$

$$x = 4 + 3\sqrt{3} \quad \text{or} \quad x = 4 - 3\sqrt{3}$$

Thus, the points $(4 + 3\sqrt{3}, 0)$ and $(4 - 3\sqrt{3}, 0)$ are on the x -axis and a distance of 6 units from the point $(4, -3)$.

- 46.** Points on the y -axis have an x -coordinate of 0. Thus, we consider points of the form $(0, y)$ that are a distance of 6 units from the point $(4, -3)$.

$$d = \sqrt{(x_2 - x_1)^2 + (y_2 - y_1)^2}$$

$$= \sqrt{(4-0)^2 + (-3-y)^2}$$

$$= \sqrt{4^2 + 9 + 6y + y^2}$$

$$= \sqrt{16 + 9 + 6y + y^2}$$

$$= \sqrt{y^2 + 6y + 25}$$

Section 2.1: The Distance and Midpoint Formulas

$$6 = \sqrt{y^2 + 6y + 25}$$

$$6^2 = (\sqrt{y^2 + 6y + 25})^2$$

$$36 = y^2 + 6y + 25$$

$$0 = y^2 + 6y - 11$$

$$y = \frac{(-6) \pm \sqrt{(6)^2 - 4(1)(-11)}}{2(1)}$$

$$= \frac{-6 \pm \sqrt{36 + 44}}{2} = \frac{-6 \pm \sqrt{80}}{2}$$

$$= \frac{-6 \pm 4\sqrt{5}}{2} = -3 \pm 2\sqrt{5}$$

$$y = -3 + 2\sqrt{5} \quad \text{or} \quad y = -3 - 2\sqrt{5}$$

Thus, the points $(0, -3 + 2\sqrt{5})$ and $(0, -3 - 2\sqrt{5})$ are on the y -axis and a distance of 6 units from the point $(4, -3)$.

47. For the x coordinate of B : $\frac{2+x_2}{2} = 5$

$$2+x_2 = 10$$

$$x_2 = 8$$

For the y coordinate of B : $\frac{1+y_2}{2} = 4$

$$1+y_2 = 8$$

$$y_2 = 7$$

Thus, the point B is $(8, 7)$

48. Let the coordinates of point B be (x, y) . Using the midpoint formula, we can write

$$(2, 3) = \left(\frac{-1+x}{2}, \frac{8+y}{2} \right).$$

This leads to two equations we can solve.

$$\frac{-1+x}{2} = 2 \qquad \frac{8+y}{2} = 3$$

$$-1+x = 4 \qquad 8+y = 6$$

$$x = 5 \qquad y = -2$$

Point B has coordinates $(5, -2)$.

49. $M = (x, y) = \left(\frac{x_1+x_2}{2}, \frac{y_1+y_2}{2} \right).$

$P_1 = (x_1, y_1) = (-3, 6)$ and $(x, y) = (-1, 4)$, so

$$x = \frac{x_1+x_2}{2} \quad \text{and} \quad y = \frac{y_1+y_2}{2}$$

$$-1 = \frac{-3+x_2}{2} \qquad 4 = \frac{6+y_2}{2}$$

$$-2 = -3+x_2 \qquad 8 = 6+y_2$$

$$1 = x_2 \qquad 2 = y_2$$

Thus, $P_2 = (1, 2)$.

50. $M = (x, y) = \left(\frac{x_1+x_2}{2}, \frac{y_1+y_2}{2} \right).$

$P_2 = (x_2, y_2) = (7, -2)$ and $(x, y) = (5, -4)$, so

$$x = \frac{x_1+x_2}{2} \quad \text{and} \quad y = \frac{y_1+y_2}{2}$$

$$5 = \frac{x_1+7}{2} \qquad -4 = \frac{y_1+(-2)}{2}$$

$$10 = x_1+7 \qquad -8 = y_1+(-2)$$

$$3 = x_1 \qquad -6 = y_1$$

Thus, $P_1 = (3, -6)$.

51. The midpoint of AB is: $D = \left(\frac{0+6}{2}, \frac{0+0}{2} \right)$

$$= (3, 0)$$

The midpoint of AC is: $E = \left(\frac{0+4}{2}, \frac{0+4}{2} \right)$

$$= (2, 2)$$

The midpoint of BC is: $F = \left(\frac{6+4}{2}, \frac{0+4}{2} \right)$

$$= (5, 2)$$

$$d(C, D) = \sqrt{(0-4)^2 + (3-4)^2}$$

$$= \sqrt{(-4)^2 + (-1)^2} = \sqrt{16+1} = \sqrt{17}$$

$$d(B, E) = \sqrt{(2-6)^2 + (2-0)^2}$$

$$= \sqrt{(-4)^2 + 2^2} = \sqrt{16+4}$$

$$= \sqrt{20} = 2\sqrt{5}$$

$$d(A, F) = \sqrt{(2-0)^2 + (5-0)^2}$$

$$= \sqrt{2^2 + 5^2} = \sqrt{4+25}$$

$$= \sqrt{29}$$

Chapter 2: Graphs

52. Let $P_1 = (0, 0)$, $P_2 = (0, 4)$, $P = (x, y)$

$$d(P_1, P_2) = \sqrt{(0-0)^2 + (4-0)^2} \\ = \sqrt{16} = 4$$

$$d(P_1, P) = \sqrt{(x-0)^2 + (y-0)^2} \\ = \sqrt{x^2 + y^2} = 4 \\ \rightarrow x^2 + y^2 = 16$$

$$d(P_2, P) = \sqrt{(x-0)^2 + (y-4)^2} \\ = \sqrt{x^2 + (y-4)^2} = 4 \\ \rightarrow x^2 + (y-4)^2 = 16$$

Therefore,

$$y^2 = (y-4)^2$$

$$y^2 = y^2 - 8y + 16$$

$$8y = 16$$

$$y = 2$$

which gives

$$x^2 + 2^2 = 16$$

$$x^2 = 12$$

$$x = \pm 2\sqrt{3}$$

Two triangles are possible. The third vertex is $(-2\sqrt{3}, 2)$ or $(2\sqrt{3}, 2)$.

53. $d(P_1, P_2) = \sqrt{(-4-2)^2 + (1-1)^2}$
 $= \sqrt{(-6)^2 + 0^2}$
 $= \sqrt{36}$
 $= 6$

$$d(P_2, P_3) = \sqrt{(-4-(-4))^2 + (-3-1)^2} \\ = \sqrt{0^2 + (-4)^2} \\ = \sqrt{16} \\ = 4$$

$$d(P_1, P_3) = \sqrt{(-4-2)^2 + (-3-1)^2} \\ = \sqrt{(-6)^2 + (-4)^2} \\ = \sqrt{36+16} \\ = \sqrt{52} \\ = 2\sqrt{13}$$

Since $[d(P_1, P_2)]^2 + [d(P_2, P_3)]^2 = [d(P_1, P_3)]^2$, the triangle is a right triangle.

54. $d(P_1, P_2) = \sqrt{(6-(-1))^2 + (2-4)^2}$
 $= \sqrt{7^2 + (-2)^2}$
 $= \sqrt{49+4}$
 $= \sqrt{53}$

$$d(P_2, P_3) = \sqrt{(4-6)^2 + (-5-2)^2} \\ = \sqrt{(-2)^2 + (-7)^2} \\ = \sqrt{4+49} \\ = \sqrt{53}$$

$$d(P_1, P_3) = \sqrt{(4-(-1))^2 + (-5-4)^2} \\ = \sqrt{5^2 + (-9)^2} \\ = \sqrt{25+81} \\ = \sqrt{106}$$

Since $[d(P_1, P_2)]^2 + [d(P_2, P_3)]^2 = [d(P_1, P_3)]^2$, the triangle is a right triangle.

Since $d(P_1, P_2) = d(P_2, P_3)$, the triangle is isosceles.

Therefore, the triangle is an isosceles right triangle.

55. $d(P_1, P_2) = \sqrt{(0-(-2))^2 + (7-(-1))^2}$
 $= \sqrt{2^2 + 8^2} = \sqrt{4+64} = \sqrt{68}$
 $= 2\sqrt{17}$

$$d(P_2, P_3) = \sqrt{(3-0)^2 + (2-7)^2} \\ = \sqrt{3^2 + (-5)^2} = \sqrt{9+25} \\ = \sqrt{34}$$

$$d(P_1, P_3) = \sqrt{(3-(-2))^2 + (2-(-1))^2} \\ = \sqrt{5^2 + 3^2} = \sqrt{25+9} \\ = \sqrt{34}$$

Since $d(P_2, P_3) = d(P_1, P_3)$, the triangle is isosceles.

Since $[d(P_1, P_3)]^2 + [d(P_2, P_3)]^2 = [d(P_1, P_2)]^2$, the triangle is also a right triangle.

Therefore, the triangle is an isosceles right triangle.

Section 2.1: The Distance and Midpoint Formulas

$$\begin{aligned}
 56. \quad d(P_1, P_2) &= \sqrt{(-4-7)^2 + (0-2)^2} \\
 &= \sqrt{(-11)^2 + (-2)^2} \\
 &= \sqrt{121+4} = \sqrt{125} \\
 &= 5\sqrt{5}
 \end{aligned}$$

$$\begin{aligned}
 d(P_2, P_3) &= \sqrt{(4-(-4))^2 + (6-0)^2} \\
 &= \sqrt{8^2 + 6^2} = \sqrt{64+36} \\
 &= \sqrt{100} \\
 &= 10
 \end{aligned}$$

$$\begin{aligned}
 d(P_1, P_3) &= \sqrt{(4-7)^2 + (6-2)^2} \\
 &= \sqrt{(-3)^2 + 4^2} = \sqrt{9+16} \\
 &= \sqrt{25} \\
 &= 5
 \end{aligned}$$

Since $[d(P_1, P_3)]^2 + [d(P_2, P_3)]^2 = [d(P_1, P_2)]^2$, the triangle is a right triangle.

57. Using the Pythagorean Theorem:

$$90^2 + 90^2 = d^2$$

$$8100 + 8100 = d^2$$

$$16200 = d^2$$

$$d = \sqrt{16200} = 90\sqrt{2} \approx 127.28 \text{ feet}$$

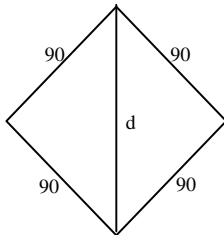

58. Using the Pythagorean Theorem:

$$60^2 + 60^2 = d^2$$

$$3600 + 3600 = d^2 \rightarrow 7200 = d^2$$

$$d = \sqrt{7200} = 60\sqrt{2} \approx 84.85 \text{ feet}$$

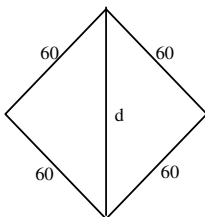

59. a. First: (90, 0), Second: (90, 90), Third: (0, 90)

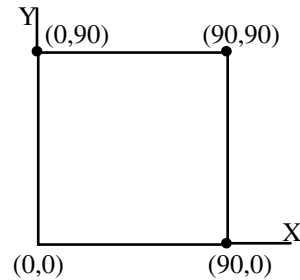

b. Using the distance formula:

$$\begin{aligned}
 d &= \sqrt{(310-90)^2 + (15-90)^2} \\
 &= \sqrt{220^2 + (-75)^2} = \sqrt{54025} \\
 &= 5\sqrt{2161} \approx 232.43 \text{ feet}
 \end{aligned}$$

c. Using the distance formula:

$$\begin{aligned}
 d &= \sqrt{(300-0)^2 + (300-90)^2} \\
 &= \sqrt{300^2 + 210^2} = \sqrt{134100} \\
 &= 30\sqrt{149} \approx 366.20 \text{ feet}
 \end{aligned}$$

60. a. First: (60, 0), Second: (60, 60), Third: (0, 60)

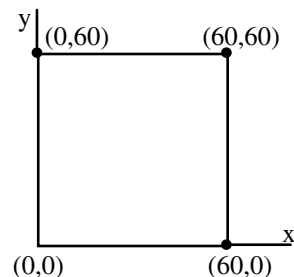

b. Using the distance formula:

$$\begin{aligned}
 d &= \sqrt{(180-60)^2 + (20-60)^2} \\
 &= \sqrt{120^2 + (-40)^2} = \sqrt{16000} \\
 &= 40\sqrt{10} \approx 126.49 \text{ feet}
 \end{aligned}$$

c. Using the distance formula:

$$\begin{aligned}
 d &= \sqrt{(220-0)^2 + (220-60)^2} \\
 &= \sqrt{220^2 + 160^2} = \sqrt{74000} \\
 &= 20\sqrt{185} \approx 272.03 \text{ feet}
 \end{aligned}$$

Chapter 2: Graphs

- 61.** The Focus heading east moves a distance $60t$ after t hours. The truck heading south moves a distance $45t$ after t hours. Their distance apart after t hours is:

$$\begin{aligned} d &= \sqrt{(60t)^2 + (45t)^2} \\ &= \sqrt{3600t^2 + 2025t^2} \\ &= \sqrt{5625t^2} \\ &= 75t \text{ miles} \end{aligned}$$

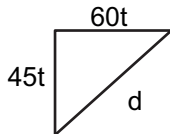

- 62.** $\frac{15 \text{ miles}}{1 \text{ hr}} \cdot \frac{5280 \text{ ft}}{1 \text{ mile}} \cdot \frac{1 \text{ hr}}{3600 \text{ sec}} = 22 \text{ ft/sec}$

$$\begin{aligned} d &= \sqrt{100^2 + (22t)^2} \\ &= \sqrt{10000 + 484t^2} \text{ feet} \end{aligned}$$

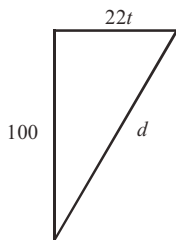

- 63. a.** The shortest side is between $P_1 = (2.6, 1.5)$ and $P_2 = (2.7, 1.7)$. The estimate for the desired intersection point is:

$$\begin{aligned} \left(\frac{x_1 + x_2}{2}, \frac{y_1 + y_2}{2} \right) &= \left(\frac{2.6 + 2.7}{2}, \frac{1.5 + 1.7}{2} \right) \\ &= \left(\frac{5.3}{2}, \frac{3.2}{2} \right) \\ &= (2.65, 1.6) \end{aligned}$$

- b.** Using the distance formula:

$$\begin{aligned} d &= \sqrt{(2.65 - 1.4)^2 + (1.6 - 1.3)^2} \\ &= \sqrt{(1.25)^2 + (0.3)^2} \\ &= \sqrt{1.5625 + 0.09} \\ &= \sqrt{1.6525} \\ &\approx 1.285 \text{ units} \end{aligned}$$

- 64.** Let $P_1 = (2014, 110.21)$ and $P_2 = (2018, 138.43)$. The midpoint is:

$$\begin{aligned} (x, y) &= \left(\frac{x_1 + x_2}{2}, \frac{y_1 + y_2}{2} \right) \\ &= \left(\frac{2014 + 2018}{2}, \frac{110.21 + 138.43}{2} \right) \\ &= \left(\frac{4032}{2}, \frac{248.64}{2} \right) \\ &= (2016, 124.32) \end{aligned}$$

The estimate for 2016 is \$124.32 billion. The estimate net sales of Costco Wholesale Corporation in 2016 is higher than the reported value of \$116.07 billion.

- 65.** For 2010 we have the ordered pair $(2010, 22113)$ and for 2018 we have the ordered pair $(2018, 25465)$. The midpoint is

$$\begin{aligned} (\text{year}, \$) &= \left(\frac{2010 + 2018}{2}, \frac{22113 + 25465}{2} \right) \\ &= \left(\frac{4028}{2}, \frac{47578}{2} \right) \\ &= (2014, 23789) \end{aligned}$$

Using the midpoint, we estimate the poverty level in 2014 to be \$23,789. This is lower than the actual value.

- 66.** Let $P_1 = (0, 0)$, $P_2 = (a, 0)$, and

$$P_3 = \left(\frac{a}{2}, \frac{\sqrt{3}a}{2} \right). \text{ Then}$$

$$\begin{aligned} d(P_1, P_2) &= \sqrt{(x_2 - x_1)^2 + (y_2 - y_1)^2} \\ &= \sqrt{(a - 0)^2 + (0 - 0)^2} = \sqrt{a^2} = |a| \end{aligned}$$

$$\begin{aligned} d(P_2, P_3) &= \sqrt{(x_2 - x_1)^2 + (y_2 - y_1)^2} \\ &= \sqrt{\left(\frac{a}{2} - a \right)^2 + \left(\frac{\sqrt{3}a}{2} - 0 \right)^2} \\ &= \sqrt{\frac{a^2}{4} + \frac{3a^2}{4}} = \sqrt{\frac{4a^2}{4}} = \sqrt{a^2} = |a| \end{aligned}$$

Section 2.1: The Distance and Midpoint Formulas

$$\begin{aligned} d(P_1, P_3) &= \sqrt{(x_2 - x_1)^2 + (y_2 - y_1)^2} \\ &= \sqrt{\left(\frac{a}{2} - 0\right)^2 + \left(\frac{\sqrt{3}a}{2} - 0\right)^2} \\ &= \sqrt{\frac{a^2}{4} + \frac{3a^2}{4}} = \sqrt{\frac{4a^2}{4}} = \sqrt{a^2} = |a| \end{aligned}$$

Since the lengths of the three sides are all equal, the triangle is an equilateral triangle.

The midpoints of the sides are

$$\begin{aligned} M_{P_1P_2} &= \left(\frac{0+a}{2}, \frac{0+0}{2}\right) = \left(\frac{a}{2}, 0\right) \\ M_{P_2P_3} &= \left(\frac{a+\frac{a}{2}}{2}, \frac{0+\frac{\sqrt{3}a}{2}}{2}\right) = \left(\frac{3a}{4}, \frac{\sqrt{3}a}{4}\right) \\ M_{P_1P_3} &= \left(\frac{0+\frac{a}{2}}{2}, \frac{0+\frac{\sqrt{3}a}{2}}{2}\right) = \left(\frac{a}{4}, \frac{\sqrt{3}a}{4}\right) \end{aligned}$$

Then,

$$\begin{aligned} d(M_{P_1P_2}, M_{P_2P_3}) &= \sqrt{\left(\frac{3a}{4} - \frac{a}{2}\right)^2 + \left(\frac{\sqrt{3}a}{4} - 0\right)^2} \\ &= \sqrt{\left(\frac{a}{4}\right)^2 + \left(\frac{\sqrt{3}a}{4}\right)^2} \\ &= \sqrt{\frac{a^2}{16} + \frac{3a^2}{16}} = \frac{|a|}{2} \\ d(M_{P_2P_3}, M_{P_1P_3}) &= \sqrt{\left(\frac{3a}{4} - \frac{a}{4}\right)^2 + \left(\frac{\sqrt{3}a}{4} - \frac{\sqrt{3}a}{4}\right)^2} \\ &= \sqrt{\left(\frac{a}{2}\right)^2 + 0^2} \\ &= \sqrt{\frac{a^2}{4}} = \frac{|a|}{2} \\ d(M_{P_1P_2}, M_{P_1P_3}) &= \sqrt{\left(\frac{a}{4} - \frac{a}{2}\right)^2 + \left(\frac{\sqrt{3}a}{4} - 0\right)^2} \\ &= \sqrt{\left(-\frac{a}{4}\right)^2 + \left(\frac{\sqrt{3}a}{4}\right)^2} \\ &= \sqrt{\frac{a^2}{16} + \frac{3a^2}{16}} = \frac{|a|}{2} \end{aligned}$$

Since the lengths of the sides of the triangle formed by the midpoints are all equal, the triangle is equilateral.

67. Let $P_1 = (0, 0)$, $P_2 = (0, s)$, $P_3 = (s, 0)$, and $P_4 = (s, s)$ be the vertices of the square.

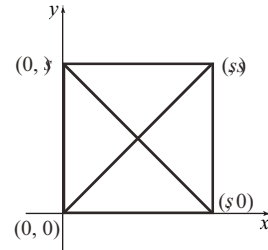

The points P_1 and P_4 are endpoints of one diagonal and the points P_2 and P_3 are the endpoints of the other diagonal.

$$\begin{aligned} M_{P_1P_4} &= \left(\frac{0+s}{2}, \frac{0+s}{2}\right) = \left(\frac{s}{2}, \frac{s}{2}\right) \\ M_{P_2P_3} &= \left(\frac{0+s}{2}, \frac{s+0}{2}\right) = \left(\frac{s}{2}, \frac{s}{2}\right) \end{aligned}$$

The midpoints of the diagonals are the same. Therefore, the diagonals of a square intersect at their midpoints.

68. Let $P = (a, 2a)$. Then

$$\begin{aligned} \sqrt{(a+5)^2 + (2a-1)^2} &= \sqrt{(a-4)^2 + (2a+4)^2} \\ (a+5)^2 + (2a-1)^2 &= (a-4)^2 + (2a+4)^2 \\ 5a^2 + 6a + 26 &= 5a^2 + 8a + 32 \\ 6a + 26 &= 8a + 32 \\ -2a &= 6 \\ a &= -3 \end{aligned}$$

Then $P = (-3, -6)$.

69. Arrange the parallelogram on the coordinate plane so that the vertices are $P_1 = (0, 0)$, $P_2 = (a, 0)$, $P_3 = (a+b, c)$ and $P_4 = (b, c)$. Then the lengths of the sides are:

$$\begin{aligned} d(P_1, P_2) &= \sqrt{(a-0)^2 + (0-0)^2} \\ &= \sqrt{a^2} = |a| \\ d(P_2, P_3) &= \sqrt{[(a+b)-a]^2 + (c-0)^2} \\ &= \sqrt{b^2 + c^2} \end{aligned}$$

Chapter 2: Graphs

$$d(P_3, P_4) = \sqrt{[b - (a + b)]^2 + (c - c)^2}$$

$$= \sqrt{a^2} = |a|$$

and

$$d(P_1, P_4) = \sqrt{(b - 0)^2 + (c - 0)^2}$$

$$= \sqrt{b^2 + c^2}$$

P_1 and P_3 are the endpoints of one diagonal, and P_2 and P_4 are the endpoints of the other diagonal. The lengths of the diagonals are

$$d(P_1, P_3) = \sqrt{[(a + b) - 0]^2 + (c - 0)^2}$$

$$= \sqrt{a^2 + 2ab + b^2 + c^2}$$

and

$$d(P_2, P_4) = \sqrt{(b - a)^2 + (c - 0)^2}$$

$$= \sqrt{a^2 - 2ab + b^2 + c^2}$$

Sum of the squares of the sides:

$$a^2 + (\sqrt{b^2 + c^2})^2 + a^2 + (\sqrt{b^2 + c^2})^2$$

$$= 2a^2 + 2b^2 + 2c^2$$

Sum of the squares of the diagonals:

$$\left(\sqrt{a^2 + 2ab + b^2 + c^2}\right)^2 + \left(\sqrt{a^2 - 2ab + b^2 + c^2}\right)^2$$

$$= 2a^2 + 2b^2 + 2c^2$$

- 70.** To find the domain, we know the denominator cannot be zero.

$$2x - 5 = 0$$

$$2x = 5$$

$$x = \frac{5}{2}$$

So the domain is all real numbers not equal to $\frac{5}{2}$

or $\left\{x \mid x \neq \frac{5}{2}\right\}$.

71. $\frac{(4)^2 - 3(4)(7) + 2}{5(4) - 2(7)} = \frac{16 - 84 + 2}{20 - 14}$

$$= \frac{-66}{6} = -11$$

72. $(5x - 2)(3x + 7) = 15x^2 + 35x - 6x - 14$

$$= 15x^2 + 29x - 14$$

73. $\frac{3x^2 + 7x + 2}{3x^2 - 11x - 4} = \frac{(3x + 1)(x + 2)}{(3x + 1)(x - 4)}$

$$= \frac{x + 2}{x - 4}$$

74. $6(x + 1)^3(2x - 7)^7 - 6(x + 1)^3(2x - 7)^7 =$

$$(x + 1)^3(2x - 5)^6 [6(2x - 5) - 5(x + 1)] =$$

$$(x + 1)^3(2x - 5)^6 [12x - 30 - 5x - 5] =$$

$$(x + 1)^3(2x - 5)^6 [7x - 35] =$$

$$7(x + 1)^3(2x - 5)^6(x - 5)$$

75. $3x^2 - 7x - 20 = 0$

$$(3x + 5)(x - 4) = 0$$

$$(3x + 5) = 0 \text{ or } (x - 4) = 0$$

$$x = -\frac{5}{3} \text{ or } x = 4$$

So the solution set is: $\left\{-\frac{5}{3}, 4\right\}$

76. $\frac{x}{x + 3} + \frac{1}{x - 3} = 1$

$$x(x - 3) + 1(x + 3) = 1(x + 3)(x - 3)$$

$$x^2 - 3x + x + 3 = x^2 - 9$$

$$-3x + x + 3 = -9$$

$$-2x = -12$$

$$x = 6$$

Section 2.2: Intercepts; Symmetry; Graphing Key Equations

77. $|7x - 4| = 31$
 $7x - 4 = -31$ or $7x - 4 = 31$
 $7x = -27$ $7x = 35$
 $x = -\frac{27}{7}$ $x = 5$

The solution set is $\left\{-\frac{27}{7}, 5\right\}$

78. $5(x - 3) + 2x \geq 6(2x - 3) - 7$
 $5x - 15 + 2x \geq 12x - 18 - 7$
 $7x - 15 \geq 12x - 25$
 $-5x \geq -10$



79. $(7 + 3i)(1 - 2i) = 7 - 14i + 3i - 6i^2$
 $= 7 - 11i - 6(-1)$
 $= 7 - 11i + 6$
 $= 13 - 11i$

Section 2.2

1. $2(x + 3) - 1 = -7$
 $2(x + 3) = -6$
 $x + 3 = -3$
 $x = -6$

The solution set is $\{-6\}$.

2. $x^2 - 9 = 0$
 $x^2 = 9$
 $x = \pm\sqrt{9} = \pm 3$

The solution set is $\{-3, 3\}$.

3. intercepts

4. $y = 0$

5. y -axis

6. 4

7. $(-3, 4)$

8. True

9. False; the y -coordinate of a point at which the graph crosses or touches the x -axis is always 0. The x -coordinate of such a point is an x -intercept.

10. False; a graph can be symmetric with respect to both coordinate axes (in such cases it will also be symmetric with respect to the origin).

For example: $x^2 + y^2 = 1$

11. d

12. c

13. $y = x + 2$

x -intercept:

$0 = x + 2$

$-2 = x$

y -intercept:

$y = 0 + 2$

$y = 2$

The intercepts are $(-2, 0)$ and $(0, 2)$.

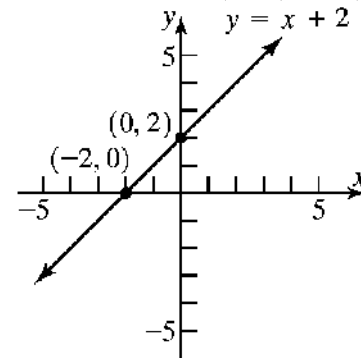

14. $y = x - 6$

x -intercept:

$0 = x - 6$

$6 = x$

y -intercept:

$y = 0 - 6$

$y = -6$

The intercepts are $(6, 0)$ and $(0, -6)$.

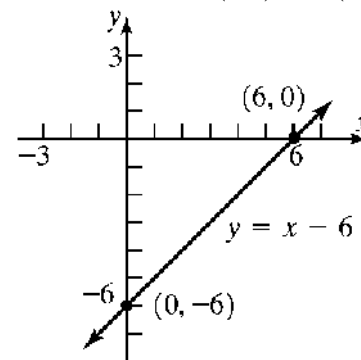

Chapter 2: Graphs

15. $y = 2x + 8$

x-intercept:	y-intercept:
$0 = 2x + 8$	$y = 2(0) + 8$
$2x = -8$	$y = 8$
$x = -4$	

The intercepts are $(-4, 0)$ and $(0, 8)$.

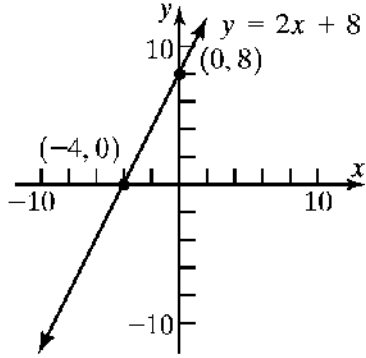

16. $y = 3x - 9$

x-intercept:	y-intercept:
$0 = 3x - 9$	$y = 3(0) - 9$
$3x = 9$	$y = -9$
$x = 3$	

The intercepts are $(3, 0)$ and $(0, -9)$.

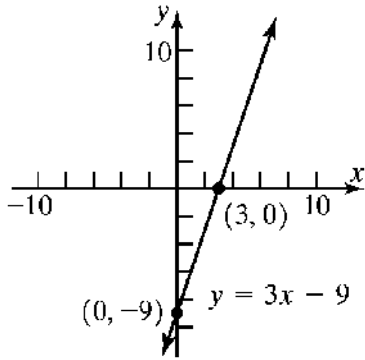

17. $y = x^2 - 1$

x-intercepts:	y-intercept:
$0 = x^2 - 1$	$y = 0^2 - 1$
$x^2 = 1$	$y = -1$
$x = \pm 1$	

The intercepts are $(-1, 0)$, $(1, 0)$, and $(0, -1)$.

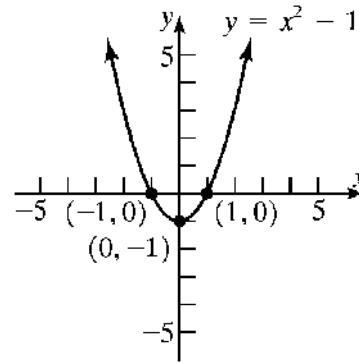

18. $y = x^2 - 9$

x-intercepts:	y-intercept:
$0 = x^2 - 9$	$y = 0^2 - 9$
$x^2 = 9$	$y = -9$
$x = \pm 3$	

The intercepts are $(-3, 0)$, $(3, 0)$, and $(0, -9)$.

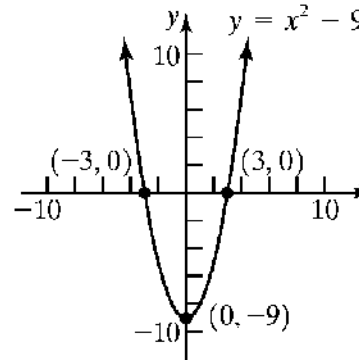

19. $y = -x^2 + 4$

x-intercepts:	y-intercept:
$0 = -x^2 + 4$	$y = -(0)^2 + 4$
$x^2 = 4$	$y = 4$
$x = \pm 2$	

The intercepts are $(-2, 0)$, $(2, 0)$, and $(0, 4)$.

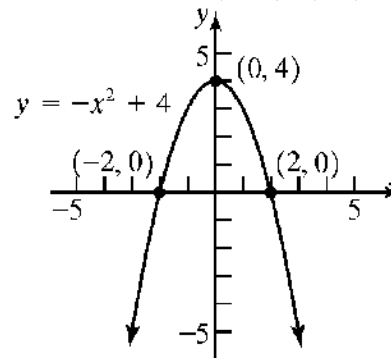

Section 2.2: Intercepts; Symmetry; Graphing Key Equations

20. $y = -x^2 + 1$

x-intercepts:

$$0 = -x^2 + 1$$

$$x^2 = 1$$

$$x = \pm 1$$

y-intercept:

$$y = -(0)^2 + 1$$

$$y = 1$$

The intercepts are $(-1, 0)$, $(1, 0)$, and $(0, 1)$.

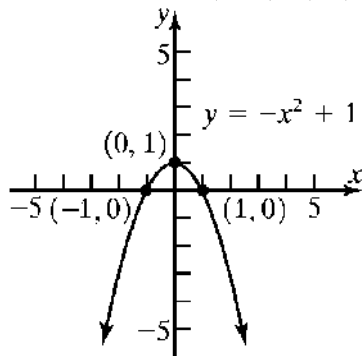

21. $2x + 3y = 6$

x-intercepts:

$$2x + 3(0) = 6$$

$$2x = 6$$

$$x = 3$$

y-intercept:

$$2(0) + 3y = 6$$

$$3y = 6$$

$$y = 2$$

The intercepts are $(3, 0)$ and $(0, 2)$.

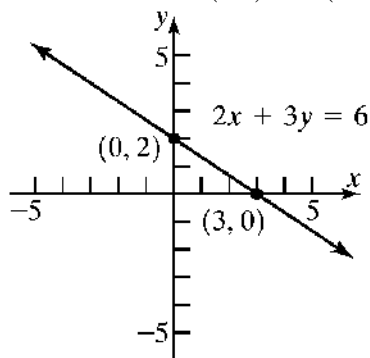

22. $5x + 2y = 10$

x-intercepts:

$$5x + 2(0) = 10$$

$$5x = 10$$

$$x = 2$$

y-intercept:

$$5(0) + 2y = 10$$

$$2y = 10$$

$$y = 5$$

The intercepts are $(2, 0)$ and $(0, 5)$.

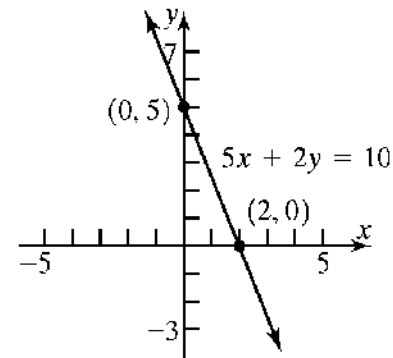

23. $9x^2 + 4y = 36$

x-intercepts:

$$9x^2 + 4(0) = 36$$

$$9x^2 = 36$$

$$x^2 = 4$$

$$x = \pm 2$$

y-intercept:

$$9(0)^2 + 4y = 36$$

$$4y = 36$$

$$y = 9$$

The intercepts are $(-2, 0)$, $(2, 0)$, and $(0, 9)$.

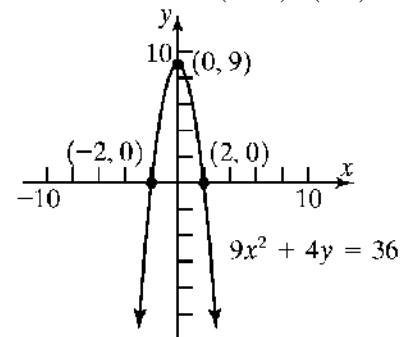

24. $4x^2 + y = 4$

x-intercepts:

$$4x^2 + 0 = 4$$

$$4x^2 = 4$$

$$x^2 = 1$$

$$x = \pm 1$$

y-intercept:

$$4(0)^2 + y = 4$$

$$y = 4$$

Chapter 2: Graphs

The intercepts are $(-1, 0)$, $(1, 0)$, and $(0, 4)$.

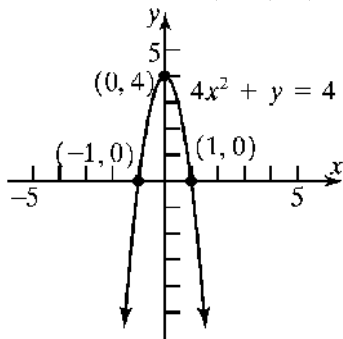

25.

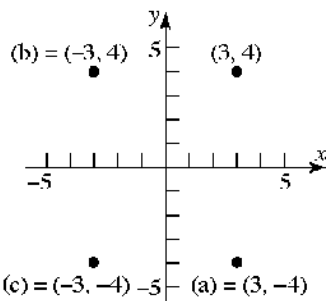

26.

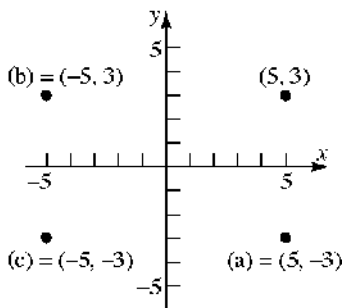

27.

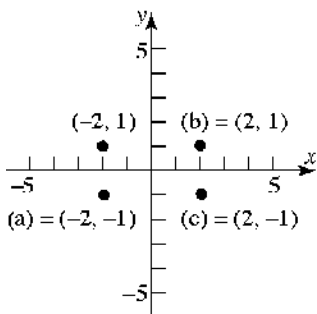

28.

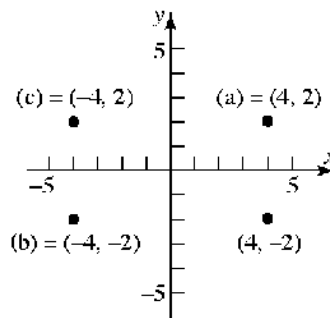

29.

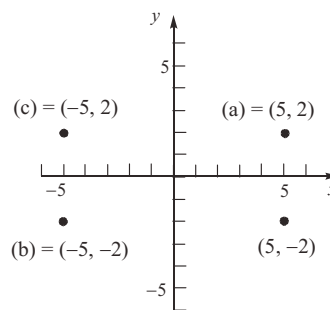

30.

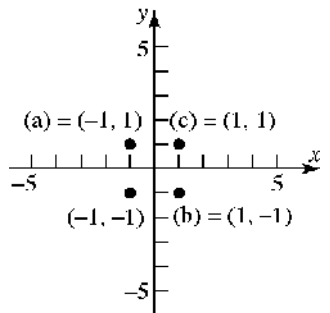

31.

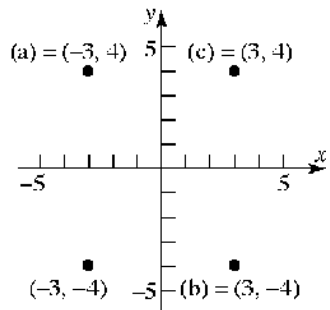

32.

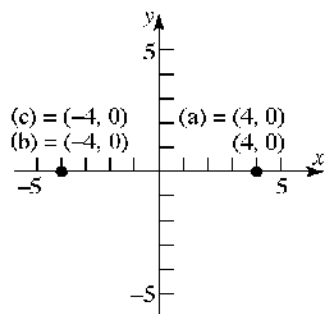

Section 2.2: Intercepts; Symmetry; Graphing Key Equations

33.

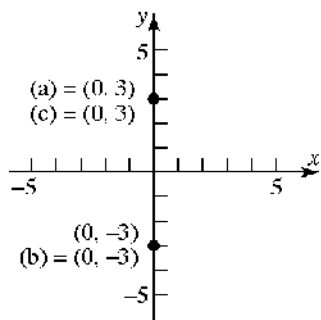

34.

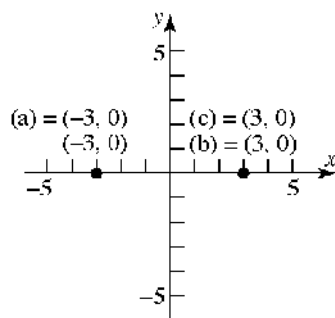

35. a. Intercepts: $(-1, 0)$ and $(1, 0)$
 b. Symmetric with respect to the x -axis, y -axis, and the origin.
36. a. Intercepts: $(0, 1)$
 b. Not symmetric to the x -axis, the y -axis, nor the origin
37. a. Intercepts: $(-\frac{\pi}{2}, 0)$, $(0, 1)$, and $(\frac{\pi}{2}, 0)$
 b. Symmetric with respect to the y -axis.
38. a. Intercepts: $(-2, 0)$, $(0, -3)$, and $(2, 0)$
 b. Symmetric with respect to the y -axis.
39. a. Intercepts: $(0, 0)$
 b. Symmetric with respect to the x -axis.
40. a. Intercepts: $(-2, 0)$, $(0, 2)$, $(0, -2)$, and $(2, 0)$
 b. Symmetric with respect to the x -axis, y -axis, and the origin.
41. a. Intercepts: $(-2, 0)$, $(0, 0)$, and $(2, 0)$
 b. Symmetric with respect to the origin.
42. a. Intercepts: $(-4, 0)$, $(0, 0)$, and $(4, 0)$
 b. Symmetric with respect to the origin.

43. a. x -intercepts: $[-2, 1]$, y -intercept 0
 b. Not symmetric to x -axis, y -axis, or origin.
44. a. x -intercepts: $[-1, 2]$, y -intercept 0
 b. Not symmetric to x -axis, y -axis, or origin.
45. a. Intercepts: none
 b. Symmetric with respect to the origin.
46. a. Intercepts: none
 b. Symmetric with respect to the x -axis.

47.

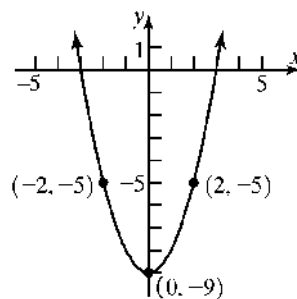

48.

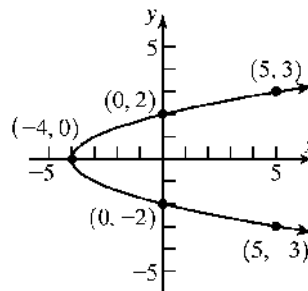

49.

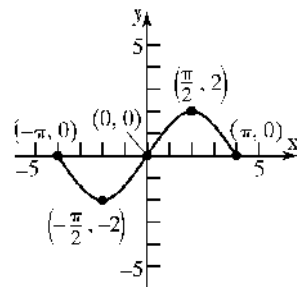

50.

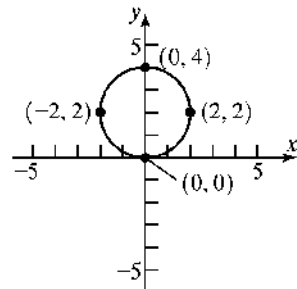

Chapter 2: Graphs

51. $y^2 = x + 16$

x -intercepts:	y -intercepts:
$0^2 = x + 16$	$y^2 = 0 + 16$
$-16 = x$	$y^2 = 16$
	$y = \pm 4$

The intercepts are $(-16, 0)$, $(0, -4)$ and $(0, 4)$.

Test x -axis symmetry: Let $y = -y$

$$(-y)^2 = x + 16$$

$$y^2 = x + 16 \text{ same}$$

Test y -axis symmetry: Let $x = -x$

$$y^2 = -x + 16 \text{ different}$$

Test origin symmetry: Let $x = -x$ and $y = -y$.

$$(-y)^2 = -x + 16$$

$$y^2 = -x + 16 \text{ different}$$

Therefore, the graph will have x -axis symmetry.

52. $y^2 = x + 9$

x -intercepts:	y -intercepts:
$(0)^2 = -x + 9$	$y^2 = 0 + 9$
$0 = -x + 9$	$y^2 = 9$
$x = 9$	$y = \pm 3$

The intercepts are $(-9, 0)$, $(0, -3)$ and $(0, 3)$.

Test x -axis symmetry: Let $y = -y$

$$(-y)^2 = x + 9$$

$$y^2 = x + 9 \text{ same}$$

Test y -axis symmetry: Let $x = -x$

$$y^2 = -x + 9 \text{ different}$$

Test origin symmetry: Let $x = -x$ and $y = -y$.

$$(-y)^2 = -x + 9$$

$$y^2 = -x + 9 \text{ different}$$

Therefore, the graph will have x -axis symmetry.

53. $y = \sqrt[3]{x}$

x -intercepts:	y -intercepts:
$0 = \sqrt[3]{x}$	$y = \sqrt[3]{0} = 0$
$0 = x$	

The only intercept is $(0, 0)$.

Test x -axis symmetry: Let $y = -y$

$$-y = \sqrt[3]{x} \text{ different}$$

Test y -axis symmetry: Let $x = -x$

$$y = \sqrt[3]{-x} = -\sqrt[3]{x} \text{ different}$$

Test origin symmetry: Let $x = -x$ and $y = -y$

$$-y = \sqrt[3]{-x} = -\sqrt[3]{x}$$

$$y = \sqrt[3]{x} \text{ same}$$

Therefore, the graph will have origin symmetry.

54. $y = \sqrt[5]{x}$

x -intercepts:	y -intercepts:
$0 = \sqrt[5]{x}$	$y = \sqrt[5]{0} = 0$
$0 = x$	

The only intercept is $(0, 0)$.

Test x -axis symmetry: Let $y = -y$

$$-y = \sqrt[5]{x} \text{ different}$$

Test y -axis symmetry: Let $x = -x$

$$y = \sqrt[5]{-x} = -\sqrt[5]{x} \text{ different}$$

Test origin symmetry: Let $x = -x$ and $y = -y$

$$-y = \sqrt[5]{-x} = -\sqrt[5]{x}$$

$$y = \sqrt[5]{x} \text{ same}$$

Therefore, the is symmetric with respect to the origin.

55. $x^2 + y - 9 = 0$

x -intercepts:	y -intercepts:
$x^2 - 9 = 0$	$0^2 + y - 9 = 0$
$x^2 = 9$	$y = 9$
$x = \pm 3$	

The intercepts are $(-3, 0)$, $(3, 0)$, and $(0, 9)$.

Test x -axis symmetry: Let $y = -y$

$$x^2 - y - 9 = 0 \text{ different}$$

Test y -axis symmetry: Let $x = -x$

$$(-x)^2 + y - 9 = 0$$

$$x^2 + y - 9 = 0 \text{ same}$$

Test origin symmetry: Let $x = -x$ and $y = -y$

$$(-x)^2 - y - 9 = 0$$

$$x^2 - y - 9 = 0 \text{ different}$$

Therefore, the graph has y -axis symmetry.

56. $x^2 - y - 4 = 0$

x -intercepts:	y -intercept:
------------------	-----------------

Section 2.2: Intercepts; Symmetry; Graphing Key Equations

$$\begin{array}{ll} x^2 - 0 - 4 = 0 & 0^2 - y - 4 = 0 \\ x^2 = 4 & -y = 4 \\ x = \pm 2 & y = -4 \end{array}$$

The intercepts are $(-2, 0)$, $(2, 0)$, and $(0, -4)$.

Test x-axis symmetry: Let $y = -y$

$$\begin{array}{l} x^2 - (-y) - 4 = 0 \\ x^2 + y - 4 = 0 \text{ different} \end{array}$$

Test y-axis symmetry: Let $x = -x$

$$\begin{array}{l} (-x)^2 - y - 4 = 0 \\ x^2 - y - 4 = 0 \text{ same} \end{array}$$

Test origin symmetry: Let $x = -x$ and $y = -y$

$$\begin{array}{l} (-x)^2 - (-y) - 4 = 0 \\ x^2 + y - 4 = 0 \text{ different} \end{array}$$

Therefore, the graph has y-axis symmetry.

57. $25x^2 + 4y^2 = 100$

x-intercepts:	y-intercepts:
$25x^2 + 4(0)^2 = 100$	$25(0)^2 + 4y^2 = 100$
$25x^2 = 100$	$4y^2 = 25$
$x^2 = 4$	$y^2 = 5$
$x = \pm 2$	$y = \pm 5$

The intercepts are $(-2, 0)$, $(2, 0)$, $(0, -5)$, and $(0, 5)$.

Test x-axis symmetry: Let $y = -y$

$$\begin{array}{l} 25x^2 + 4(-y)^2 = 100 \\ 25x^2 + 4y^2 = 100 \text{ same} \end{array}$$

Test y-axis symmetry: Let $x = -x$

$$\begin{array}{l} 25(-x)^2 + 4y^2 = 100 \\ 25x^2 + 4y^2 = 100 \text{ same} \end{array}$$

Test origin symmetry: Let $x = -x$ and $y = -y$

$$\begin{array}{l} 25(-x)^2 + 4(-y)^2 = 100 \\ 25x^2 + 4y^2 = 100 \text{ same} \end{array}$$

Therefore, the graph has x-axis, y-axis, and origin symmetry.

58. $4x^2 + y^2 = 4$

x-intercepts:	y-intercepts:
$4x^2 + 0^2 = 4$	$4(0)^2 + y^2 = 4$
$4x^2 = 4$	$y^2 = 4$
$x^2 = 1$	$y = \pm 2$
$x = \pm 1$	

The intercepts are $(-1, 0)$, $(1, 0)$, $(0, -2)$, and $(0, 2)$.

Test x-axis symmetry: Let $y = -y$

$$\begin{array}{l} 4x^2 + (-y)^2 = 4 \\ 4x^2 + y^2 = 4 \text{ same} \end{array}$$

Test y-axis symmetry: Let $x = -x$

$$\begin{array}{l} 4(-x)^2 + y^2 = 4 \\ 4x^2 + y^2 = 4 \text{ same} \end{array}$$

Test origin symmetry: Let $x = -x$ and $y = -y$

$$\begin{array}{l} 4(-x)^2 + (-y)^2 = 4 \\ 4x^2 + y^2 = 4 \text{ same} \end{array}$$

Therefore, the graph has x-axis, y-axis, and origin symmetry.

59. $y = x^3 - 64$

x-intercepts:	y-intercepts:
$0 = x^3 - 64$	$y = 0^3 - 64$
$x^3 = 64$	$y = -64$
$x = 4$	

The intercepts are $(4, 0)$ and $(0, -64)$.

Test x-axis symmetry: Let $y = -y$

$$-y = x^3 - 64 \text{ different}$$

Test y-axis symmetry: Let $x = -x$

$$\begin{array}{l} y = (-x)^3 - 64 \\ y = -x^3 - 64 \text{ different} \end{array}$$

Test origin symmetry: Let $x = -x$ and $y = -y$

$$\begin{array}{l} -y = (-x)^3 - 64 \\ y = x^3 + 64 \text{ different} \end{array}$$

Therefore, the graph has no symmetry.

60. $y = x^4 - 1$

x-intercepts:	y-intercepts:
$0 = x^4 - 1$	$y = 0^4 - 1$
$x^4 = 1$	$y = -1$
$x = \pm 1$	

The intercepts are $(-1, 0)$, $(1, 0)$, and $(0, -1)$.

Test x-axis symmetry: Let $y = -y$

$$-y = x^4 - 1 \text{ different}$$

Chapter 2: Graphs

Test y-axis symmetry: Let $x = -x$

$$y = (-x)^4 - 1$$

$$y = x^4 - 1 \text{ same}$$

Test origin symmetry: Let $x = -x$ and $y = -y$

$$-y = (-x)^4 - 1$$

$$-y = x^4 - 1 \text{ different}$$

Therefore, the graph has y-axis symmetry.

61. $y = x^2 - 2x - 8$

x-intercepts: y-intercepts:

$$0 = x^2 - 2x - 8 \qquad y = 0^2 - 2(0) - 8$$

$$0 = (x - 4)(x + 2) \qquad y = -8$$

$$x = 4 \text{ or } x = -2$$

The intercepts are (4, 0), (-2, 0), and (0, -8).

Test x-axis symmetry: Let $y = -y$

$$-y = x^2 - 2x - 8 \text{ different}$$

Test y-axis symmetry: Let $x = -x$

$$y = (-x)^2 - 2(-x) - 8$$

$$y = x^2 + 2x - 8 \text{ different}$$

Test origin symmetry: Let $x = -x$ and $y = -y$

$$-y = (-x)^2 - 2(-x) - 8$$

$$-y = x^2 + 2x - 8 \text{ different}$$

Therefore, the graph has no symmetry.

62. $y = x^2 + 4$

x-intercepts: y-intercepts:

$$0 = x^2 + 4 \qquad y = 0^2 + 4$$

$$x^2 = -4 \qquad y = 4$$

no real solution

The only intercept is (0, 4).

Test x-axis symmetry: Let $y = -y$

$$-y = x^2 + 4 \text{ different}$$

Test y-axis symmetry: Let $x = -x$

$$y = (-x)^2 + 4$$

$$y = x^2 + 4 \text{ same}$$

Test origin symmetry: Let $x = -x$ and $y = -y$

$$-y = (-x)^2 + 4$$

$$-y = x^2 + 4 \text{ different}$$

Therefore, the graph has y-axis symmetry.

63. $y = \frac{4x}{x^2 + 16}$

x-intercepts:

$$0 = \frac{4x}{x^2 + 16}$$

$$4x = 0$$

$$x = 0$$

The only intercept is (0, 0).

Test x-axis symmetry: Let $y = -y$

$$-y = \frac{4x}{x^2 + 16} \text{ different}$$

Test y-axis symmetry: Let $x = -x$

$$y = \frac{4(-x)}{(-x)^2 + 16}$$

$$y = -\frac{4x}{x^2 + 16} \text{ different}$$

Test origin symmetry: Let $x = -x$ and $y = -y$

$$-y = \frac{4(-x)}{(-x)^2 + 16}$$

$$-y = -\frac{4x}{x^2 + 16}$$

$$y = \frac{4x}{x^2 + 16} \text{ same}$$

Therefore, the graph has origin symmetry.

64. $y = \frac{x^2 - 4}{2x}$

x-intercepts:

$$0 = \frac{x^2 - 4}{2x}$$

$$x^2 - 4 = 0$$

$$x^2 = 4$$

$$x = \pm 2$$

The intercepts are (-2, 0) and (2, 0).

Test x-axis symmetry: Let $y = -y$

$$-y = \frac{x^2 - 4}{2x} \text{ different}$$

Test y-axis symmetry: Let $x = -x$

$$y = \frac{(-x)^2 - 4}{2(-x)}$$

$$y = -\frac{x^2 - 4}{2x} \text{ different}$$

y-intercepts:

$$y = \frac{4(0)}{0^2 + 16} = \frac{0}{16} = 0$$

y-intercepts:

$$y = \frac{0^2 - 4}{2(0)} = \frac{-4}{0}$$

undefined

Section 2.2: Intercepts; Symmetry; Graphing Key Equations

Test origin symmetry: Let $x = -x$ and $y = -y$

$$-y = \frac{(-x)^2 - 4}{2(-x)}$$

$$-y = \frac{x^2 - 4}{-2x}$$

$$y = \frac{x^2 - 4}{2x} \text{ same}$$

Therefore, the graph has origin symmetry.

65. $y = \frac{-x^3}{x^2 - 9}$

x-intercepts:

$$0 = \frac{-x^3}{x^2 - 9}$$

$$-x^3 = 0$$

$$x = 0$$

The only intercept is $(0, 0)$.

Test x-axis symmetry: Let $y = -y$

$$-y = \frac{-x^3}{x^2 - 9}$$

$$y = \frac{x^3}{x^2 - 9} \text{ different}$$

Test y-axis symmetry: Let $x = -x$

$$y = \frac{-(-x)^3}{(-x)^2 - 9}$$

$$y = \frac{x^3}{x^2 - 9} \text{ different}$$

Test origin symmetry: Let $x = -x$ and $y = -y$

$$-y = \frac{-(-x)^3}{(-x)^2 - 9}$$

$$-y = \frac{x^3}{x^2 - 9}$$

$$y = \frac{-x^3}{x^2 - 9} \text{ same}$$

Therefore, the graph has origin symmetry.

66. $y = \frac{x^4 + 1}{2x^5}$

x-intercepts:

y-intercepts:

$$0 = \frac{x^4 + 1}{2x^5} \quad y = \frac{0^4 + 1}{2(0)^5} = \frac{1}{0}$$

$$x^4 = -1$$

no real solution

There are no intercepts for the graph of this equation.

Test x-axis symmetry: Let $y = -y$

$$-y = \frac{x^4 + 1}{2x^5} \text{ different}$$

Test y-axis symmetry: Let $x = -x$

$$y = \frac{(-x)^4 + 1}{2(-x)^5}$$

$$y = \frac{x^4 + 1}{-2x^5} \text{ different}$$

Test origin symmetry: Let $x = -x$ and $y = -y$

$$-y = \frac{(-x)^4 + 1}{2(-x)^5}$$

$$-y = \frac{x^4 + 1}{-2x^5}$$

$$y = \frac{x^4 + 1}{2x^5} \text{ same}$$

Therefore, the graph has origin symmetry.

67. $y = x^3$

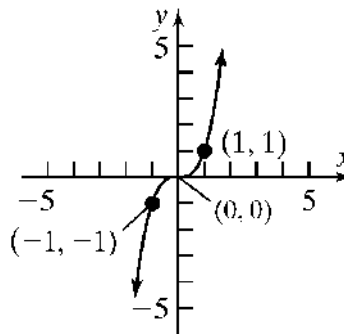

Chapter 2: Graphs

68. $x = y^2$

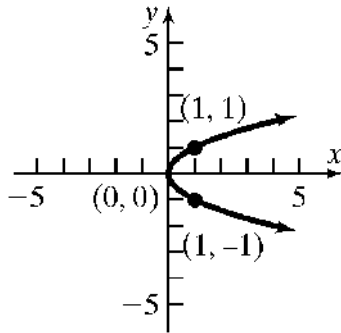

69. $y = \sqrt{x}$

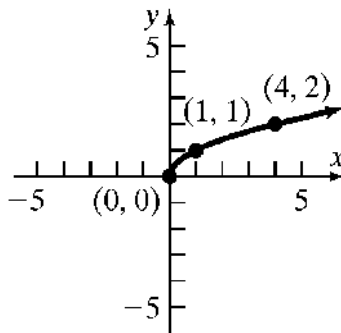

70. $y = \frac{1}{x}$

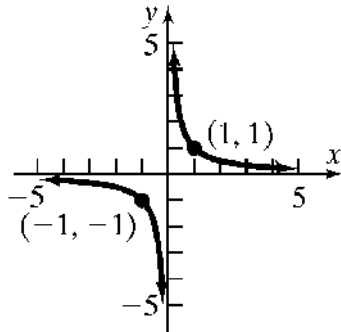

71. If the point $(a, 4)$ is on the graph of

$y = x^2 + 3x$, then we have

$4 = a^2 + 3a$

$0 = a^2 + 3a - 4$

$0 = (a + 4)(a - 1)$

$a + 4 = 0$ or $a - 1 = 0$

$a = -4$ or $a = 1$

Thus, $a = -4$ or $a = 1$.

72. If the point $(a, -5)$ is on the graph of

$y = x^2 + 6x$, then we have

$-5 = a^2 + 6a$

$0 = a^2 + 6a + 5$

$0 = (a + 5)(a + 1)$

$a + 5 = 0$ or $a + 1 = 0$

$a = -5$ or $a = -1$

Thus, $a = -5$ or $a = -1$.

73. a. $0 = x^2 - 5$

$x^2 = 5$

$x = \pm\sqrt{5}$

The x-intercepts are $x = -\sqrt{5}$ and $x = \sqrt{5}$.

$y = (0)^2 - 5 = -5$

The y-intercept is $y = -5$.

The intercepts are $(-\sqrt{5}, 0)$, $(\sqrt{5}, 0)$, and $(0, -5)$.

b. x-axis (replace y by $-y$):

$-y = x^2 - 5$

$y = 5 - x^2$ different

y-axis (replace x by $-x$):

$y = (-x)^2 - 5 = x^2 - 5$ same

origin (replace x by $-x$ and y by $-y$):

$-y = (-x)^2 - 5$

$y = 5 - x^2$ different

The equation has y-axis symmetry.

c. $y = x^2 - 5$

Additional points:

Section 2.2: Intercepts; Symmetry; Graphing Key Equations

x	$y = x^2 - 5$	(x, y)
1	$y = 1^2 - 5 = -4$	$(1, -4)$
-1	from symmetry	$(-1, -4)$
2	$y = 2^2 - 5 = -1$	$(2, -1)$
-2	from symmetry	$(-2, -1)$

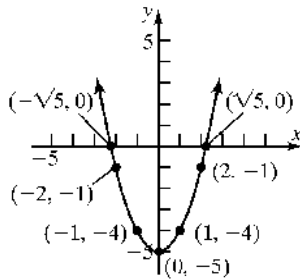

x	$y = x^2 - 8$	(x, y)
1	$y = 1^2 - 8 = -7$	$(1, -7)$
-1	from symmetry	$(-1, -7)$
2	$y = 2^2 - 8 = -4$	$(2, -4)$
-2	from symmetry	$(-2, -4)$

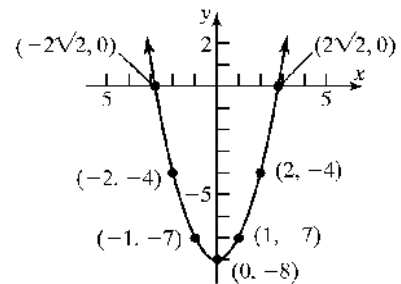

- 74. a.** $0 = x^2 - 8$
 $x^2 = 8$
 $x = \pm 2\sqrt{2}$
 The x-intercepts are $x = -2\sqrt{2}$ and $x = 2\sqrt{2}$.
 $y = (0)^2 - 8 = -8$
 The y-intercept is $y = -8$.
 The intercepts are $(-2\sqrt{2}, 0)$, $(2\sqrt{2}, 0)$, and $(0, -8)$.

- b.** x-axis (replace y by $-y$):
 $-y = x^2 - 8$
 $y = 8 - x^2$ different
 y-axis (replace x by $-x$):
 $y = (-x)^2 - 8 = x^2 - 8$ same
 origin (replace x by $-x$ and y by $-y$):
 $-y = (-x)^2 - 8$
 $y = 8 - x^2$ different
 The equation has y-axis symmetry.

- c.** $y = x^2 - 8$
 Additional points:

- 75. a.** $x - (0)^2 = -9$
 $x = -9$
 The x-intercept is $x = -9$.
 $(0) - y^2 = -9$
 $-y^2 = -9$
 $y^2 = 9 \rightarrow y = \pm 3$
 The y-intercepts are $y = -3$ and $y = 3$.
 The intercepts are $(-9, 0)$, $(0, -3)$, and $(0, 3)$.

- b.** x-axis (replace y by $-y$):
 $x - (-y)^2 = -9$
 $x - y^2 = -9$ same
 y-axis (replace x by $-x$):
 $-x - y^2 = -9$
 $x + y^2 = 9$ different
 origin (replace x by $-x$ and y by $-y$):
 $-x - (-y)^2 = -9$
 $-x - y^2 = -9$
 $x + y^2 = 9$ different
 The equation has x-axis symmetry.

Chapter 2: Graphs

c. $x - y^2 = -9$ or $x = y^2 - 9$

Additional points:

y	$x = y^2 - 9$	(x, y)
2	$x = 2^2 - 9 = -5$	$(-5, 2)$
-2	from symmetry	$(-5, -2)$

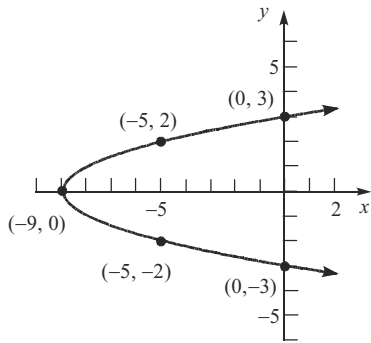

76. a. $x + (0)^2 = 4$
 $x = 4$

The x-intercept is $x = 4$.

$(0) + y^2 = 4$

$y^2 = 4 \rightarrow y = \pm 2$

The y-intercepts are $y = -2$ and $y = 2$.

The intercepts are $(4, 0)$, $(0, -2)$, and $(0, 2)$.

b. x-axis (replace y by $-y$):

$x + (-y)^2 = 4$

$x + y^2 = 4$ same

y-axis (replace x by $-x$):

$-x + y^2 = 4$

$x - y^2 = -4$ different

origin (replace x by $-x$ and y by $-y$):

$-x + (-y)^2 = 4$

$-x + y^2 = 4$

$x - y^2 = -4$ different

The equation has x-axis symmetry.

c. $x + y^2 = 4$ or $x = 4 - y^2$

Additional points:

y	$x = 4 - y^2$	(x, y)
1	$x = 4 - 1^2 = 3$	$(3, 1)$
-1	from symmetry	$(3, -1)$

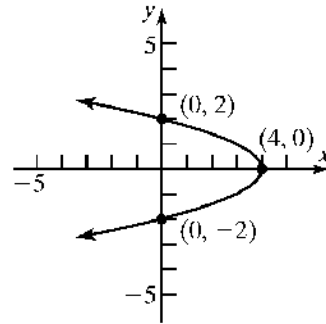

77. a. $x^2 + (0)^2 = 9$
 $x^2 = 9$

$x = \pm 3$

The x-intercepts are $x = -3$ and $x = 3$.

$(0)^2 + y^2 = 9$

$y^2 = 9$

$y = \pm 3$

The y-intercepts are $y = -3$ and $y = 3$.

The intercepts are $(-3, 0)$, $(3, 0)$, $(0, -3)$, and $(0, 3)$.

b. x-axis (replace y by $-y$):

$x^2 + (-y)^2 = 9$

$x^2 + y^2 = 9$ same

y-axis (replace x by $-x$):

$(-x)^2 + y^2 = 9$

$x^2 + y^2 = 9$ same

origin (replace x by $-x$ and y by $-y$):

$(-x)^2 + (-y)^2 = 9$

$x^2 + y^2 = 9$ same

The equation has x-axis symmetry, y-axis symmetry, and origin symmetry.

Section 2.2: Intercepts; Symmetry; Graphing Key Equations

c. $x^2 + y^2 = 9$

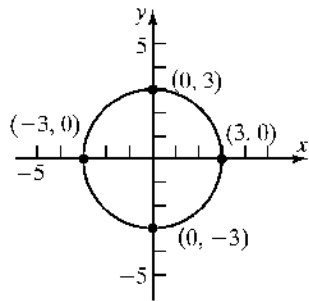

78. a. $x^2 + (0)^2 = 16$

$$x^2 = 16$$

$$x = \pm 4$$

The x-intercepts are $x = -4$ and $x = 4$.

$$(0)^2 + y^2 = 16$$

$$y^2 = 16$$

$$y = \pm 4$$

The y-intercepts are $y = -4$ and $y = 4$.

The intercepts are $(-4, 0)$, $(4, 0)$, $(0, -4)$, and $(0, 4)$.

b. x-axis (replace y by $-y$):

$$x^2 + (-y)^2 = 16$$

$$x^2 + y^2 = 16 \text{ same}$$

y-axis (replace x by $-x$):

$$(-x)^2 + y^2 = 16$$

$$x^2 + y^2 = 16 \text{ same}$$

origin (replace x by $-x$ and y by $-y$):

$$(-x)^2 + (-y)^2 = 16$$

$$x^2 + y^2 = 16 \text{ same}$$

The equation has x-axis symmetry, y-axis symmetry, and origin symmetry.

c. $x^2 + y^2 = 16$

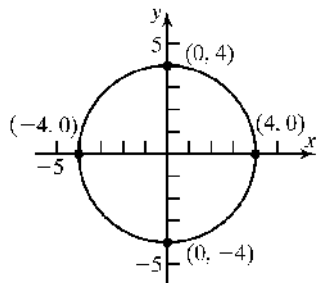

79. a. $0 = x^3 - 4x$

$$0 = x(x^2 - 4)$$

$$x = 0 \text{ or } x^2 - 4 = 0$$

$$x^2 = 4$$

$$x = \pm 2$$

The x-intercepts are $x = 0$, $x = -2$, and $x = 2$.

$$y = 0^3 - 4(0) = 0$$

The y-intercept is $y = 0$.

The intercepts are $(0, 0)$, $(-2, 0)$, and $(2, 0)$.

b. x-axis (replace y by $-y$):

$$-y = x^3 - 4x$$

$$y = 4x - x^3 \text{ different}$$

y-axis (replace x by $-x$):

$$y = (-x)^3 - 4(-x)$$

$$y = -x^3 + 4x \text{ different}$$

origin (replace x by $-x$ and y by $-y$):

$$-y = (-x)^3 - 4(-x)$$

$$-y = -x^3 + 4x$$

$$y = x^3 - 4x \text{ same}$$

The equation has origin symmetry.

c. $y = x^3 - 4x$

Additional points:

x	$y = x^3 - 4x$	(x, y)
1	$y = 1^3 - 4(1) = -3$	$(1, -3)$
-1	from symmetry	$(-1, 3)$

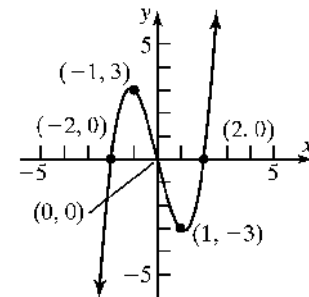

Chapter 2: Graphs

80. a. $0 = x^3 - x$

$$0 = x(x^2 - 1)$$

$$x = 0 \text{ or } x^2 - 1 = 0$$

$$x^2 = 1$$

$$x = \pm 1$$

The x -intercepts are $x = 0$, $x = -1$, and $x = 1$.

$$y = 0^3 - (0) = 0$$

The y -intercept is $y = 0$.

The intercepts are $(0,0)$, $(-1,0)$, and $(1,0)$.

b. x -axis (replace y by $-y$):

$$-y = x^3 - x$$

$$y = x - x^3 \text{ different}$$

y -axis (replace x by $-x$):

$$y = (-x)^3 - (-x)$$

$$y = -x^3 + x \text{ different}$$

origin (replace x by $-x$ and y by $-y$):

$$-y = (-x)^3 - (-x)$$

$$-y = -x^3 + x$$

$$y = x^3 - x \text{ same}$$

The equation has origin symmetry.

c. $y = x^3 - 4x$

Additional points:

x	$y = x^3 - 4x$	(x, y)
2	$y = 2^3 - (2) = 6$	$(2, 6)$
-2	from symmetry	$(-2, -6)$

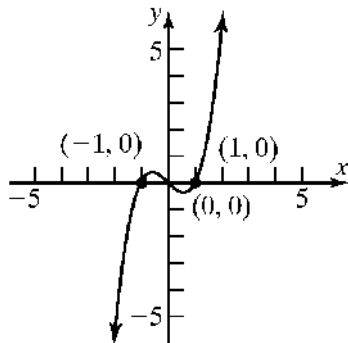

81. For a graph with origin symmetry, if the point (a,b) is on the graph, then so is the point $(-a,-b)$. Since the point $(1,2)$ is on the graph of an equation with origin symmetry, the point $(-1,-2)$ must also be on the graph.

82. For a graph with y -axis symmetry, if the point (a,b) is on the graph, then so is the point $(-a,b)$. Since 6 is an x -intercept in this case, the point $(6,0)$ is on the graph of the equation. Due to the y -axis symmetry, the point $(-6,0)$ must also be on the graph. Therefore, -6 is another x -intercept.

83. For a graph with origin symmetry, if the point (a,b) is on the graph, then so is the point $(-a,-b)$. Since -4 is an x -intercept in this case, the point $(-4,0)$ is on the graph of the equation. Due to the origin symmetry, the point $(4,0)$ must also be on the graph. Therefore, 4 is another x -intercept.

84. For a graph with x -axis symmetry, if the point (a,b) is on the graph, then so is the point $(a,-b)$. Since 2 is a y -intercept in this case, the point $(0,2)$ is on the graph of the equation. Due to the x -axis symmetry, the point $(0,-2)$ must also be on the graph. Therefore, -2 is another y -intercept.

85. a. $(x^2 + y^2 - x)^2 = x^2 + y^2$

x -intercepts:

$$(x^2 + (0)^2 - x)^2 = x^2 + (0)^2$$

$$(x^2 - x)^2 = x^2$$

$$x^4 - 2x^3 + x^2 = x^2$$

$$x^4 - 2x^3 = 0$$

$$x^3(x - 2) = 0$$

$$x^3 = 0 \text{ or } x - 2 = 0$$

$$x = 0 \qquad x = 2$$

Section 2.2: Intercepts; Symmetry; Graphing Key Equations

y -intercepts:

$$\left((0)^2 + y^2 - 0\right)^2 = (0)^2 + y^2$$

$$(y^2)^2 = y^2$$

$$y^4 = y^2$$

$$y^4 - y^2 = 0$$

$$y^2(y^2 - 1) = 0$$

$$y^2 = 0 \quad \text{or} \quad y^2 - 1 = 0$$

$$y = 0 \quad y^2 = 1$$

$$y = \pm 1$$

The intercepts are $(0, 0)$, $(2, 0)$, $(0, -1)$, and $(0, 1)$.

b. Test x -axis symmetry: Let $y = -y$

$$(x^2 + (-y)^2 - x)^2 = x^2 + (-y)^2$$

$$(x^2 + y^2 - x)^2 = x^2 + y^2 \quad \text{same}$$

Test y -axis symmetry: Let $x = -x$

$$\left((-x)^2 + y^2 - (-x)\right)^2 = (-x)^2 + y^2$$

$$(x^2 + y^2 + x)^2 = x^2 + y^2 \quad \text{different}$$

Test origin symmetry: Let $x = -x$ and $y = -y$

$$\left((-x)^2 + (-y)^2 - (-x)\right)^2 = (-x)^2 + (-y)^2$$

$$(x^2 + y^2 + x)^2 = x^2 + y^2 \quad \text{different}$$

Thus, the graph will have x -axis symmetry.

86. a. $16y^2 = 120x - 225$

y -intercepts:

$$16y^2 = 120(0) - 225$$

$$16y^2 = -225$$

$$y^2 = -\frac{225}{16}$$

no real solution

x -intercepts:

$$16(0)^2 = 120x - 225$$

$$0 = 120x - 225$$

$$-120x = -225$$

$$x = \frac{-225}{-120} = \frac{15}{8}$$

The only intercept is $\left(\frac{15}{8}, 0\right)$.

b. Test x -axis symmetry: Let $y = -y$

$$16(-y)^2 = 120x - 225$$

$$16y^2 = 120x - 225 \quad \text{same}$$

Test y -axis symmetry: Let $x = -x$

$$16y^2 = 120(-x) - 225$$

$$16y^2 = -120x - 225 \quad \text{different}$$

Test origin symmetry: Let $x = -x$ and $y = -y$

$$16(-y)^2 = 120(-x) - 225$$

$$16y^2 = -120x - 225 \quad \text{different}$$

Thus, the graph has x -axis symmetry.

87. Let $y = 0$.

$$(x^2 + 0^2)^2 = a^2(x^2 - 0^2)$$

$$x^4 = a^2(x^2)$$

$$x^4 - a^2x^2 = 0$$

$$x^2(x^2 - a^2) = 0$$

$$x^2 = 0 \quad \text{or} \quad (x^2 - a^2) = 0$$

$$x = 0 \quad \text{or} \quad x^2 = a^2$$

$$x = -a, a$$

Let $x = 0$.

$$(0^2 + y^2)^2 = a^2(0^2 - y^2)$$

$$y^4 = a^2(-y^2)$$

$$y^4 + a^2y^2 = 0$$

$$y^2(y^2 + a^2) = 0$$

$$y = 0$$

(Note that the solutions to $y^2 + a^2 = 0$ are not real)

So the intercepts are $(0, 0)$, $(a, 0)$ and $(-a, 0)$.

Test x -axis symmetry: Replace y by $-y$

$$(x^2 + (-y)^2)^2 = a^2(x^2 - (-y)^2)$$

$$(x^2 + y^2)^2 = a^2(x^2 - y^2) \quad \text{equivalent}$$

Chapter 2: Graphs

Test y-axis symmetry: replace x by $-x$

$$((-x)^2 + y^2)^2 = a^2((-x)^2 - y^2)$$

$$(x^2 + y^2)^2 = a^2(x^2 - y^2) \text{ equivalent}$$

Test origin symmetry: replace x by $-x$ and y by $-y$

$$((-x)^2 + (-y)^2)^2 = a^2((-x)^2 - (-y)^2)$$

$$(x^2 + y^2)^2 = a^2(x^2 - y^2) \text{ equivalent}$$

The graph is symmetric by respect to the x -axis, the y -axis, and the origin.

88. Let $y = 0$.

$$(x^2 + 0^2 - ax)^2 = b^2(x^2 + 0^2)$$

$$x^4 - 2ax^3 + a^2x^2 - b^2x^2 = 0$$

$$x^2[(x - (a + b))(x - (a - b))] = 0$$

$$x = 0 \text{ or } x = a + b$$

$$\text{or } x = a - b$$

Let $x = 0$.

$$(0^2 + y^2 - a \cdot 0)^2 = b^2(0^2 + y^2)$$

$$y^4 - b^2y^2 = 0$$

$$y^2(y + b)(y - b) = 0$$

$$y = 0, y = -b, y = b$$

So the intercepts are $(0,0)$, $(a-b,0)$, $(a+b,0)$, $(0,-b)$, $(0,b)$.

Test x-axis symmetry: replace y by $-y$

$$[x^2 + (-y)^2 - ax]^2 = b^2[x^2 + (-y)^2]$$

$$(x^2 + y^2 - ax)^2 = b^2(x^2 + y^2) \text{ Equivalent}$$

Test y-axis symmetry: replace x by $-x$

$$[(-x)^2 + y^2 - a(-x)]^2 = b^2[(-x)^2 + y^2]$$

$$(x^2 + y^2 + ax)^2 = b^2(x^2 + y^2) \text{ Not equivalent}$$

Test origin symmetry: replace x by $-x$ and y by $-y$

$$[(-x)^2 + (-y)^2 - a(-x)]^2 = b^2[(-x)^2 + (-y)^2]$$

$$(x^2 + y^2 + ax)^2 = b^2(x^2 + y^2) \text{ No equivalent}$$

The graph is symmetric with respect to the x -axis only.

89. Answers will vary. One example:

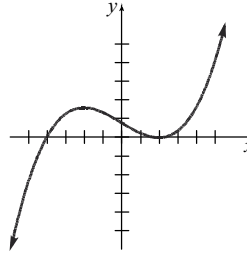

90. Answers will vary.

Case 1: Graph has x -axis and y -axis symmetry, show origin symmetry.

$$(x, y) \text{ on graph} \rightarrow (x, -y) \text{ on graph}$$

(from x -axis symmetry)

$$(x, -y) \text{ on graph} \rightarrow (-x, -y) \text{ on graph}$$

(from y -axis symmetry)

Since the point $(-x, -y)$ is also on the graph, the graph has origin symmetry.

Case 2: Graph has x -axis and origin symmetry, show y -axis symmetry.

$$(x, y) \text{ on graph} \rightarrow (x, -y) \text{ on graph}$$

(from x -axis symmetry)

$$(x, -y) \text{ on graph} \rightarrow (-x, y) \text{ on graph}$$

(from origin symmetry)

Since the point $(-x, y)$ is also on the graph, the graph has y -axis symmetry.

Case 3: Graph has y -axis and origin symmetry, show x -axis symmetry.

$$(x, y) \text{ on graph} \rightarrow (-x, y) \text{ on graph}$$

(from y -axis symmetry)

$$(-x, y) \text{ on graph} \rightarrow (x, -y) \text{ on graph}$$

(from origin symmetry)

Since the point $(x, -y)$ is also on the graph, the graph has x -axis symmetry.

91. Answers may vary. The graph must contain the points $(-2,5)$, $(-1,3)$, and $(0,2)$. For the graph to be symmetric about the y -axis, the graph must also contain the points $(2,5)$ and $(1,3)$ (note that $(0,2)$ is on the y -axis).

For the graph to also be symmetric with respect to the x -axis, the graph must also contain the

Section 2.2: Intercepts; Symmetry; Graphing Key Equations

points $(-2, -5)$, $(-1, -3)$, $(0, -2)$, $(2, -5)$, and $(1, -3)$. Recall that a graph with two of the symmetries (x-axis, y-axis, origin) will necessarily have the third. Therefore, if the original graph with y-axis symmetry also has x-axis symmetry, then it will also have origin symmetry.

92. $\frac{6+(-2)}{6-(-2)} = \frac{4}{8} = \frac{1}{2}$

93. $3x^2 - 30x + 75 =$
 $3(x^2 - 10x + 25) =$
 $3(x-5)(x-5) = 3(x-5)^2$

94. $(2x^2y^3)^3(3x^3y)^2 = (2x^2)^3(y^3)^3(3x^3)^2(y)^2$
 $= (8x^6)(y^9)(9x^6)(y^2)$
 $= 72x^{12}y^{11}$

95.
$$\begin{array}{r} 3 \overline{) 2 \ -7 \ 0 \ 7 \ 6} \\ \underline{6 \ -3 \ -9 \ 6} \\ 2 \ -1 \ -3 \ -2 \ 0 \end{array}$$

The quotient is $2x^3 - x^2 - 3x - 2$ and the remainder is 0.

96. $\sqrt{2x+5} - 1 = x$
 $\sqrt{2x+5} = x+1$
 $2x+5 = (x+1)^2$
 $2x+5 = x^2 + 2x+1$
 $x^2 = 4$
 $x = \pm 2$

Check each solution:

$\sqrt{2(2)+5} - 1 =$
 $\sqrt{4+5} - 1 =$
 $\sqrt{9} - 1 = 3 - 1 = 2$
 $\sqrt{2(-2)+5} - 1 =$
 $\sqrt{-4+5} - 1 =$
 $\sqrt{1} - 1 = 1 - 1 \neq -2$

The solution set is $\{2\}$.

97. $1 < 3(4-x) - 5 \leq 19$
 $1 < 12 - 3x - 5 \leq 19$
 $1 < 7 - 3x \leq 19$
 $-6 < -3x \leq 12$
 $2 > x \geq -4$
 $-4 \leq x < 2$

The solution set in interval notation is: $[-4, 2)$

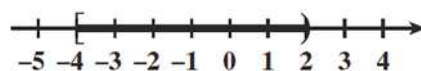

98. $x^2 - 8x + 4 = 0$
 $x^2 - 8x = -4$
 $x^2 - 8x + 16 = -4 + 16$
 $(x-4)^2 = 12$
 $x-4 = \pm\sqrt{12}$
 $x = 4 \pm\sqrt{12}$
 $= 4 \pm 2\sqrt{3}$

The solution set is $\{4 - 2\sqrt{3}, 4 + 2\sqrt{3}\}$.

99. $3x^2 + x - 1 = 0$
 $a = 3, \quad b = 1, \quad c = -1$
 $x = \frac{-1 \pm \sqrt{1^2 - 4(3)(-1)}}{2(3)} = \frac{-1 \pm \sqrt{1+12}}{6} = \frac{-1 \pm \sqrt{13}}{6}$

The solution set is $\left\{ \frac{-1 - \sqrt{13}}{6}, \frac{-1 + \sqrt{13}}{6} \right\}$.

100. Let r be the radius of the pipe with the deposits and $r + 2$ be the original radius. Then the area of the cross section of the pipe with the deposits is $A = \pi r^2$ and the area of the cross section of the original pipe is $A = \pi(r + 2)^2$. Since the area of the pipe with deposits is 30% less than the area of the original pipe, we have $\pi r^2 = .7\pi(r + 2)^2$. Solving for r we have

$$\begin{aligned} \pi r^2 &= .7\pi(r + 2)^2 \\ r^2 &= .7(r^2 + 4r + 4) \\ r^2 &= .7r^2 + 2.8r + 2.8 \\ 0 &= -0.3r^2 + 2.8r + 2.8 \\ r &= \frac{-2.8 \pm \sqrt{2.8^2 - 4(-0.3)(2.8)}}{2(-0.3)} \\ &= \frac{-2.8 \pm \sqrt{11.2}}{-0.6} = 10.2444 \end{aligned}$$

Chapter 2: Graphs

The radius without the deposit is
 $10.2444 + 2 = 12.2444$ and the diameter is
 $2(12.2444) = 24.49$ mm.

101. $\sqrt{-196} = \sqrt{(-1)(196)} = 14i$

Section 2.3

1. a. 2; 2; 1
 b. -2
 c. 0
 d. ii, iv
 e. ii

2. undefined; 0

3. 3; 2

x-intercept: $2x + 3(0) = 6$

$$2x = 6$$

$$x = 3$$

y-intercept: $2(0) + 3y = 6$

$$3y = 6$$

$$y = 2$$

4. True

5. False; the slope is $\frac{3}{2}$.

$$2y = 3x + 5$$

$$y = \frac{3}{2}x + \frac{5}{2}$$

6. True; $2(1) + (2) = 4$

$$2 + 2 = 4$$

$$4 = 4 \text{ True}$$

7. $m_1 = m_2$; y-intercepts; $m_1 \cdot m_2 = -1$

8. 2

9. $-\frac{1}{2}$

10. d

11. b

12. d

13. a. Slope = $\frac{1-0}{2-0} = \frac{1}{2}$

b. If x increases by 2 units, y will increase by 1 unit.

14. a. Slope = $\frac{1-0}{-2-0} = -\frac{1}{2}$

b. If x increases by 2 units, y will decrease by 1 unit.

15. a. Slope = $\frac{1-2}{1-(-2)} = -\frac{1}{3}$

b. If x increases by 3 units, y will decrease by 1 unit.

16. a. Slope = $\frac{2-1}{2-(-1)} = \frac{1}{3}$

b. If x increases by 3 units, y will increase by 1 unit.

17. Slope = $\frac{y_2 - y_1}{x_2 - x_1} = \frac{0-3}{4-2} = -\frac{3}{2}$

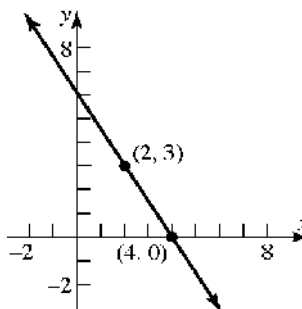

18. Slope = $\frac{y_2 - y_1}{x_2 - x_1} = \frac{4-2}{3-4} = \frac{2}{-1} = -2$

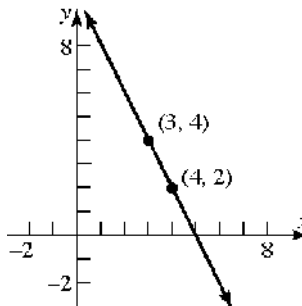

19. Slope = $\frac{y_2 - y_1}{x_2 - x_1} = \frac{1 - 3}{2 - (-2)} = \frac{-2}{4} = -\frac{1}{2}$

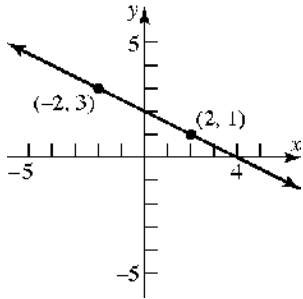

23. Slope = $\frac{y_2 - y_1}{x_2 - x_1} = \frac{-2 - 2}{-1 - (-1)} = \frac{-4}{0}$ undefined.

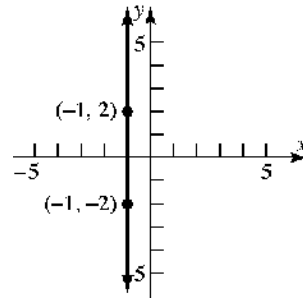

20. Slope = $\frac{y_2 - y_1}{x_2 - x_1} = \frac{3 - 1}{2 - (-1)} = \frac{2}{3}$

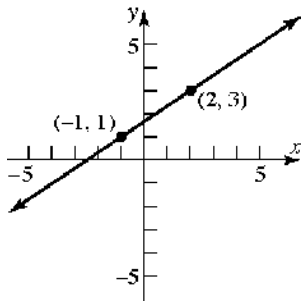

24. Slope = $\frac{y_2 - y_1}{x_2 - x_1} = \frac{2 - 0}{2 - 2} = \frac{2}{0}$ undefined.

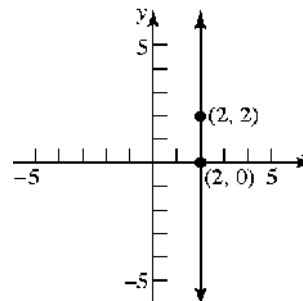

21. Slope = $\frac{y_2 - y_1}{x_2 - x_1} = \frac{-1 - (-1)}{2 - (-3)} = \frac{0}{5} = 0$

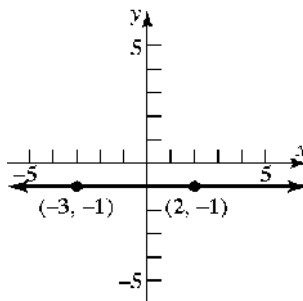

25. $P = (1, 2); m = 3$

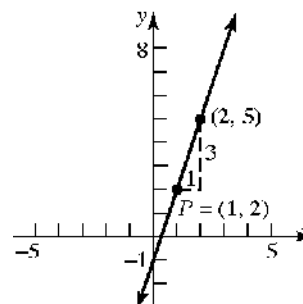

22. Slope = $\frac{y_2 - y_1}{x_2 - x_1} = \frac{2 - 2}{-5 - 4} = \frac{0}{-9} = 0$

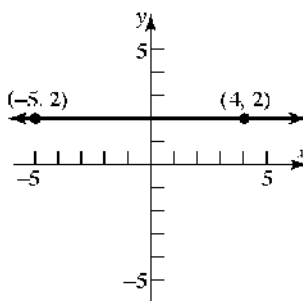

26. $P = (2, 1); m = 4$

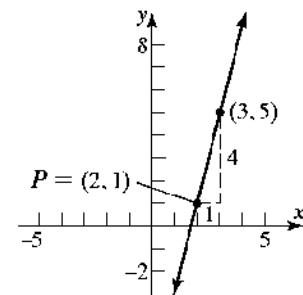

Chapter 2: Graphs

27. $P = (2, 4); m = -\frac{3}{4}$

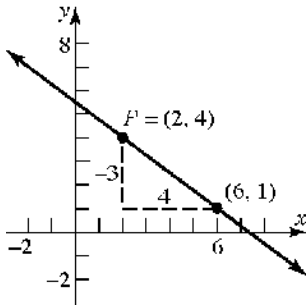

28. $P = (1, 3); m = -\frac{2}{5}$

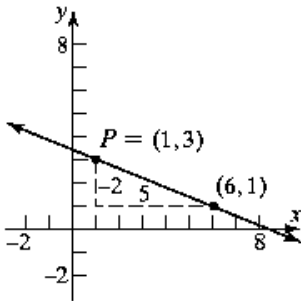

29. $P = (-1, 3); m = 0$

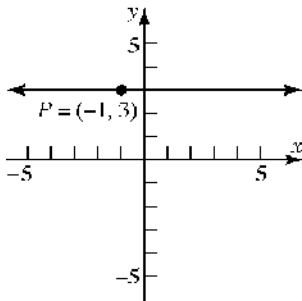

30. $P = (2, -4); m = 0$

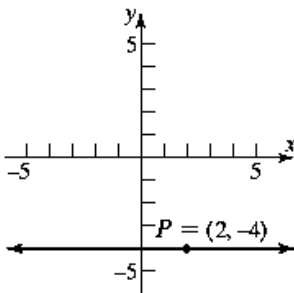

31. $P = (0, 3);$ slope undefined

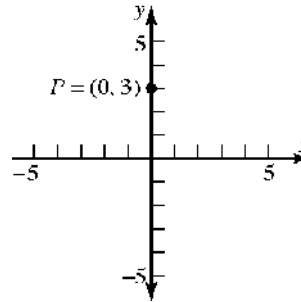

(note: the line is the y -axis)

32. $P = (-2, 0);$ slope undefined

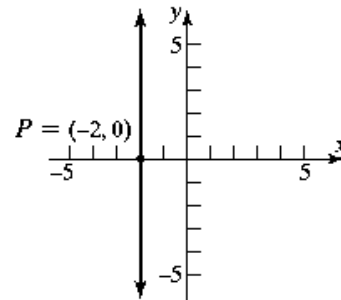

33. $P = (1, 2); m = 3; y - 2 = 3(x - 1)$

34. $P = (2, 1); m = 4; y - 1 = 4(x - 2)$

35. $P = (2, 4); m = -\frac{3}{4}; y - 4 = -\frac{3}{4}(x - 2)$

36. $P = (1, 3); m = -\frac{2}{5}; y - 3 = -\frac{2}{5}(x - 1)$

37. $P = (-1, 3); m = 0; y - 3 = 0$

38. $P = (2, -4); m = 0; y + 4 = 0$

39. Slope = $4 = \frac{4}{1}$; point: $(1, 2)$

If x increases by 1 unit, then y increases by 4 units.

Answers will vary. Three possible points are:

$$x = 1 + 1 = 2 \text{ and } y = 2 + 4 = 6$$

$$(2, 6)$$

$$x = 2 + 1 = 3 \text{ and } y = 6 + 4 = 10$$

$$(3, 10)$$

$$x = 3 + 1 = 4 \text{ and } y = 10 + 4 = 14$$

$$(4, 14)$$

40. Slope = $2 = \frac{2}{1}$; point: $(-2, 3)$

If x increases by 1 unit, then y increases by 2 units.

Answers will vary. Three possible points are:

$$x = -2 + 1 = -1 \text{ and } y = 3 + 2 = 5$$

$$(-1, 5)$$

$$x = -1 + 1 = 0 \text{ and } y = 5 + 2 = 7$$

$$(0, 7)$$

$$x = 0 + 1 = 1 \text{ and } y = 7 + 2 = 9$$

$$(1, 9)$$

41. Slope = $-\frac{3}{2} = \frac{-3}{2}$; point: $(2, -4)$

If x increases by 2 units, then y decreases by 3 units.

Answers will vary. Three possible points are:

$$x = 2 + 2 = 4 \text{ and } y = -4 - 3 = -7$$

$$(4, -7)$$

$$x = 4 + 2 = 6 \text{ and } y = -7 - 3 = -10$$

$$(6, -10)$$

$$x = 6 + 2 = 8 \text{ and } y = -10 - 3 = -13$$

$$(8, -13)$$

42. Slope = $\frac{4}{3}$; point: $(-3, 2)$

If x increases by 3 units, then y increases by 4 units.

Answers will vary. Three possible points are:

$$x = -3 + 3 = 0 \text{ and } y = 2 + 4 = 6$$

$$(0, 6)$$

$$x = 0 + 3 = 3 \text{ and } y = 6 + 4 = 10$$

$$(3, 10)$$

$$x = 3 + 3 = 6 \text{ and } y = 10 + 4 = 14$$

$$(6, 14)$$

43. Slope = $-2 = \frac{-2}{1}$; point: $(-2, -3)$

If x increases by 1 unit, then y decreases by 2 units.

Answers will vary. Three possible points are:

$$x = -2 + 1 = -1 \text{ and } y = -3 - 2 = -5$$

$$(-1, -5)$$

$$x = -1 + 1 = 0 \text{ and } y = -5 - 2 = -7$$

$$(0, -7)$$

$$x = 0 + 1 = 1 \text{ and } y = -7 - 2 = -9$$

$$(1, -9)$$

44. Slope = $-1 = \frac{-1}{1}$; point: $(4, 1)$

If x increases by 1 unit, then y decreases by 1 unit.

Answers will vary. Three possible points are:

$$x = 4 + 1 = 5 \text{ and } y = 1 - 1 = 0$$

$$(5, 0)$$

$$x = 5 + 1 = 6 \text{ and } y = 0 - 1 = -1$$

$$(6, -1)$$

$$x = 6 + 1 = 7 \text{ and } y = -1 - 1 = -2$$

$$(7, -2)$$

45. $(0, 0)$ and $(2, 1)$ are points on the line.

$$\text{Slope} = \frac{1-0}{2-0} = \frac{1}{2}$$

y -intercept is 0; using $y = mx + b$:

$$y = \frac{1}{2}x + 0$$

$$2y = x$$

$$0 = x - 2y$$

$$x - 2y = 0 \text{ or } y = \frac{1}{2}x$$

46. $(0, 0)$ and $(-2, 1)$ are points on the line.

$$\text{Slope} = \frac{1-0}{-2-0} = \frac{1}{-2} = -\frac{1}{2}$$

y -intercept is 0; using $y = mx + b$:

$$y = -\frac{1}{2}x + 0$$

$$2y = -x$$

$$x + 2y = 0$$

$$x + 2y = 0 \text{ or } y = -\frac{1}{2}x$$

Chapter 2: Graphs

47. $(-1, 3)$ and $(1, 1)$ are points on the line.

$$\text{Slope} = \frac{1-3}{1-(-1)} = \frac{-2}{2} = -1$$

$$\text{Using } y - y_1 = m(x - x_1)$$

$$y - 1 = -1(x - 1)$$

$$y - 1 = -x + 1$$

$$y = -x + 2$$

$$x + y = 2 \text{ or } y = -x + 2$$

48. $(-1, 1)$ and $(2, 2)$ are points on the line.

$$\text{Slope} = \frac{2-1}{2-(-1)} = \frac{1}{3}$$

$$\text{Using } y - y_1 = m(x - x_1)$$

$$y - 1 = \frac{1}{3}(x - (-1))$$

$$y - 1 = \frac{1}{3}(x + 1)$$

$$y - 1 = \frac{1}{3}x + \frac{1}{3}$$

$$y = \frac{1}{3}x + \frac{4}{3}$$

$$x - 3y = -4 \text{ or } y = \frac{1}{3}x + \frac{4}{3}$$

49. $y - y_1 = m(x - x_1)$, $m = 2$

$$y - 3 = 2(x - 3)$$

$$y - 3 = 2x - 6$$

$$y = 2x - 3$$

$$2x - y = 3 \text{ or } y = 2x - 3$$

50. $y - y_1 = m(x - x_1)$, $m = -1$

$$y - 2 = -1(x - 1)$$

$$y - 2 = -x + 1$$

$$y = -x + 3$$

$$x + y = 3 \text{ or } y = -x + 3$$

51. $y - y_1 = m(x - x_1)$, $m = -\frac{1}{2}$

$$y - 2 = -\frac{1}{2}(x - 1)$$

$$y - 2 = -\frac{1}{2}x + \frac{1}{2}$$

$$y = -\frac{1}{2}x + \frac{5}{2}$$

$$x + 2y = 5 \text{ or } y = -\frac{1}{2}x + \frac{5}{2}$$

52. $y - y_1 = m(x - x_1)$, $m = 1$

$$y - 1 = 1(x - (-1))$$

$$y - 1 = x + 1$$

$$y = x + 2$$

$$x - y = -2 \text{ or } y = x + 2$$

53. Slope = 3; containing $(-2, 3)$

$$y - y_1 = m(x - x_1)$$

$$y - 3 = 3(x - (-2))$$

$$y - 3 = 3x + 6$$

$$y = 3x + 9$$

$$3x - y = -9 \text{ or } y = 3x + 9$$

54. Slope = 2; containing the point $(4, -3)$

$$y - y_1 = m(x - x_1)$$

$$y - (-3) = 2(x - 4)$$

$$y + 3 = 2x - 8$$

$$y = 2x - 11$$

$$2x - y = 11 \text{ or } y = 2x - 11$$

55. Slope = $\frac{1}{2}$; containing the point $(3, 1)$

$$y - y_1 = m(x - x_1)$$

$$y - 1 = \frac{1}{2}(x - 3)$$

$$y - 1 = \frac{1}{2}x - \frac{3}{2}$$

$$y = \frac{1}{2}x - \frac{1}{2}$$

$$x - 2y = 1 \text{ or } y = \frac{1}{2}x - \frac{1}{2}$$

56. Slope = $-\frac{2}{3}$; containing $(1, -1)$

$$y - y_1 = m(x - x_1)$$

$$y - (-1) = -\frac{2}{3}(x - 1)$$

$$y + 1 = -\frac{2}{3}x + \frac{2}{3}$$

$$y = -\frac{2}{3}x - \frac{1}{3}$$

$$2x + 3y = -1 \text{ or } y = -\frac{2}{3}x - \frac{1}{3}$$

57. Containing (1, 3) and (-1, 2)

$$m = \frac{2-3}{-1-1} = \frac{-1}{-2} = \frac{1}{2}$$

$$y - y_1 = m(x - x_1)$$

$$y - 3 = \frac{1}{2}(x - 1)$$

$$y - 3 = \frac{1}{2}x - \frac{1}{2}$$

$$y = \frac{1}{2}x + \frac{5}{2}$$

$$x - 2y = -5 \text{ or } y = \frac{1}{2}x + \frac{5}{2}$$

58. Containing the points (-3, 4) and (2, 5)

$$m = \frac{5-4}{2-(-3)} = \frac{1}{5}$$

$$y - y_1 = m(x - x_1)$$

$$y - 5 = \frac{1}{5}(x - 2)$$

$$y - 5 = \frac{1}{5}x - \frac{2}{5}$$

$$y = \frac{1}{5}x + \frac{23}{5}$$

$$x - 5y = -23 \text{ or } y = \frac{1}{5}x + \frac{23}{5}$$

59. Slope = -3; y-intercept = 3

$$y = mx + b$$

$$y = -3x + 3$$

$$3x + y = 3 \text{ or } y = -3x + 3$$

60. Slope = -2; y-intercept = -2

$$y = mx + b$$

$$y = -2x + (-2)$$

$$2x + y = -2 \text{ or } y = -2x - 2$$

61. x-intercept = -4; y-intercept = 4

Points are (-4, 0) and (0, 4)

$$m = \frac{4-0}{0-(-4)} = \frac{4}{4} = 1$$

$$y = mx + b$$

$$y = 1x + 4$$

$$y = x + 4$$

$$x - y = -4 \text{ or } y = x + 4$$

62. x-intercept = 2; y-intercept = -1

Points are (2, 0) and (0, -1)

$$m = \frac{-1-0}{0-2} = \frac{-1}{-2} = \frac{1}{2}$$

$$y = mx + b$$

$$y = \frac{1}{2}x - 1$$

$$x - 2y = 2 \text{ or } y = \frac{1}{2}x - 1$$

63. Slope undefined; containing the point (2, 4)

This is a vertical line.

$$x = 2 \quad \text{No slope-intercept form.}$$

64. Slope undefined; containing the point (3, 8)

This is a vertical line.

$$x = 3 \quad \text{No slope-intercept form.}$$

65. Horizontal lines have slope
- $m = 0$
- and take the

form $y = b$. Therefore, the horizontal linepassing through the point (-3, 2) is $y = 2$.

66. Vertical lines have an undefined slope and take

the form $x = a$. Therefore, the vertical linepassing through the point (4, -5) is $x = 4$.

67. Parallel to
- $y = 2x$
- ; Slope = 2

Containing (-1, 2)

$$y - y_1 = m(x - x_1)$$

$$y - 2 = 2(x - (-1))$$

$$y - 2 = 2x + 2 \rightarrow y = 2x + 4$$

$$2x - y = -4 \text{ or } y = 2x + 4$$

68. Parallel to
- $y = -3x$
- ; Slope = -3; Containing the

point (-1, 2)

$$y - y_1 = m(x - x_1)$$

$$y - 2 = -3(x - (-1))$$

$$y - 2 = -3x - 3 \rightarrow y = -3x - 1$$

$$3x + y = -1 \text{ or } y = -3x - 1$$

69. Parallel to
- $x - 2y = -5$
- ;

Slope = $\frac{1}{2}$; Containing the point (0, 0)

$$y - y_1 = m(x - x_1)$$

$$y - 0 = \frac{1}{2}(x - 0) \rightarrow y = \frac{1}{2}x$$

$$x - 2y = 0 \text{ or } y = \frac{1}{2}x$$

Chapter 2: Graphs

- 70.** Parallel to $2x - y = -2$; Slope = 2

Containing the point $(0, 0)$

$$y - y_1 = m(x - x_1)$$

$$y - 0 = 2(x - 0)$$

$$y = 2x$$

$$2x - y = 0 \text{ or } y = 2x$$

- 71.** Parallel to $x = 5$; Containing $(4, 2)$

This is a vertical line.

$$x = 4 \text{ No slope-intercept form.}$$

- 72.** Parallel to $y = 5$; Containing the point $(4, 2)$

This is a horizontal line. Slope = 0

$$y = 2$$

- 73.** Perpendicular to $y = \frac{1}{2}x + 4$; Containing $(1, -2)$

Slope of perpendicular = -2

$$y - y_1 = m(x - x_1)$$

$$y - (-2) = -2(x - 1)$$

$$y + 2 = -2x + 2 \rightarrow y = -2x$$

$$2x + y = 0 \text{ or } y = -2x$$

- 74.** Perpendicular to $y = 2x - 3$; Containing the point $(1, -2)$

Slope of perpendicular = $-\frac{1}{2}$

$$y - y_1 = m(x - x_1)$$

$$y - (-2) = -\frac{1}{2}(x - 1)$$

$$y + 2 = -\frac{1}{2}x + \frac{1}{2} \rightarrow y = -\frac{1}{2}x - \frac{3}{2}$$

$$x + 2y = -3 \text{ or } y = -\frac{1}{2}x - \frac{3}{2}$$

- 75.** Perpendicular to $x - 2y = -5$; Containing the point $(0, 4)$

Slope of perpendicular = -2

$$y = mx + b$$

$$y = -2x + 4$$

$$2x + y = 4 \text{ or } y = -2x + 4$$

- 76.** Perpendicular to $2x + y = 2$; Containing the point $(-3, 0)$

Slope of perpendicular = $\frac{1}{2}$

$$y - y_1 = m(x - x_1)$$

$$y - 0 = \frac{1}{2}(x - (-3)) \rightarrow y = \frac{1}{2}x + \frac{3}{2}$$

$$x - 2y = -3 \text{ or } y = \frac{1}{2}x + \frac{3}{2}$$

- 77.** Perpendicular to $x = 8$; Containing $(3, 4)$
Slope of perpendicular = 0 (horizontal line)
 $y = 4$

- 78.** Perpendicular to $y = 8$;
Containing the point $(3, 4)$
Slope of perpendicular is undefined (vertical line). $x = 3$ No slope-intercept form.

- 79.** $y = 2x + 3$; Slope = 2; y -intercept = 3

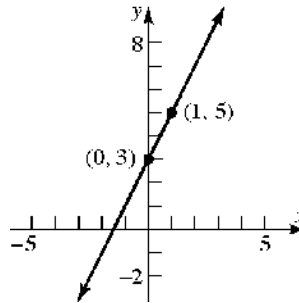

- 80.** $y = -3x + 4$; Slope = -3 ; y -intercept = 4

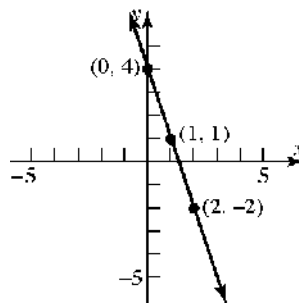

81. $\frac{1}{2}y = x - 1$; $y = 2x - 2$

Slope = 2; y-intercept = -2

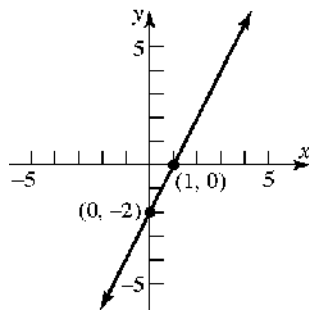

85. $x + 2y = 4$; $2y = -x + 4 \rightarrow y = -\frac{1}{2}x + 2$

Slope = $-\frac{1}{2}$; y-intercept = 2

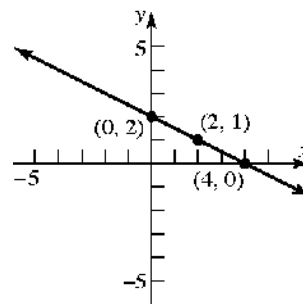

82. $\frac{1}{3}x + y = 2$; $y = -\frac{1}{3}x + 2$

Slope = $-\frac{1}{3}$; y-intercept = 2

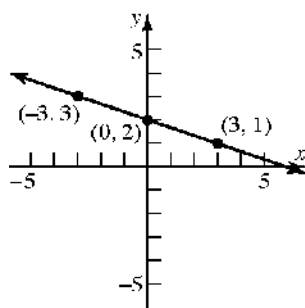

86. $-x + 3y = 6$; $3y = x + 6 \rightarrow y = \frac{1}{3}x + 2$

Slope = $\frac{1}{3}$; y-intercept = 2

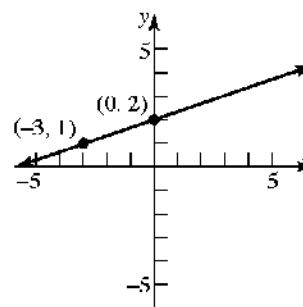

83. $y = \frac{1}{2}x + 2$; Slope = $\frac{1}{2}$; y-intercept = 2

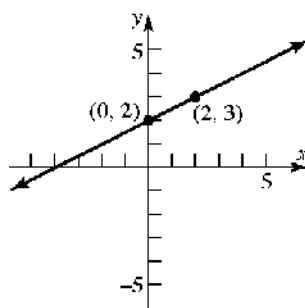

87. $2x - 3y = 6$; $-3y = -2x + 6 \rightarrow y = \frac{2}{3}x - 2$

Slope = $\frac{2}{3}$; y-intercept = -2

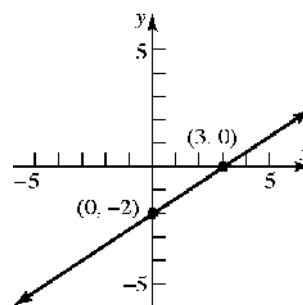

84. $y = 2x + \frac{1}{2}$; Slope = 2; y-intercept = $\frac{1}{2}$

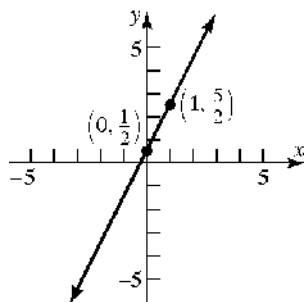

Chapter 2: Graphs

88. $3x + 2y = 6$; $2y = -3x + 6 \rightarrow y = -\frac{3}{2}x + 3$

Slope = $-\frac{3}{2}$; y-intercept = 3

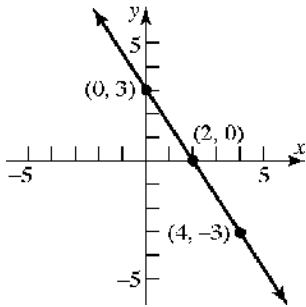

89. $x + y = 1$; $y = -x + 1$

Slope = -1; y-intercept = 1

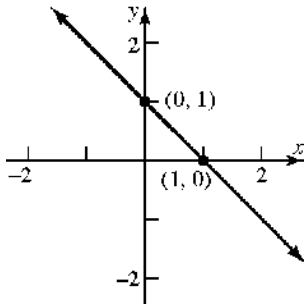

90. $x - y = 2$; $y = x - 2$

Slope = 1; y-intercept = -2

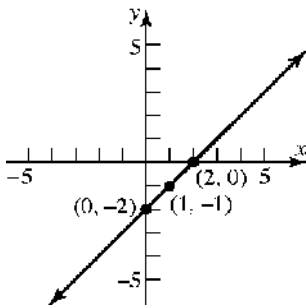

91. $x = -4$; Slope is undefined
y-intercept - none

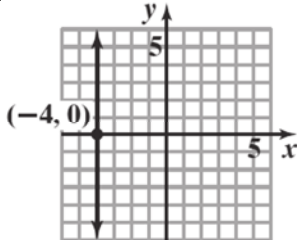

92. $y = -1$; Slope = 0; y-intercept = -1

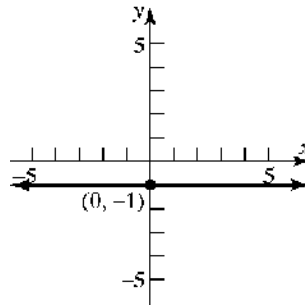

93. $y = 5$; Slope = 0; y-intercept = 5

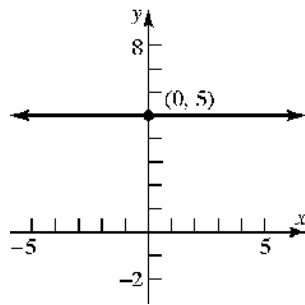

94. $x = 2$; Slope is undefined
y-intercept - none

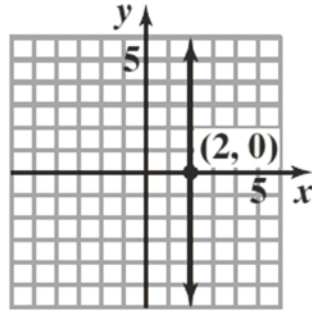

95. $y - x = 0$; $y = x$
Slope = 1; y-intercept = 0

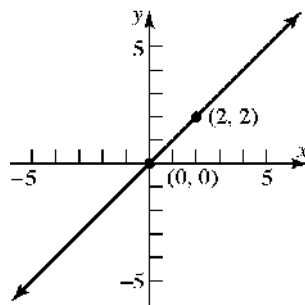

96. $x + y = 0$; $y = -x$
Slope = -1 ; y -intercept = 0

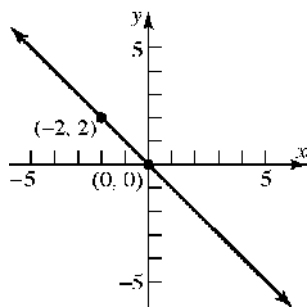

97. $2y - 3x = 0$; $2y = 3x \rightarrow y = \frac{3}{2}x$
Slope = $\frac{3}{2}$; y -intercept = 0

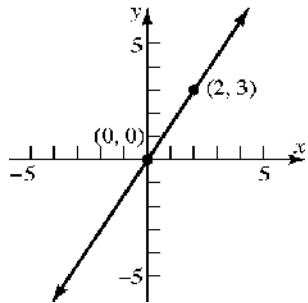

98. $3x + 2y = 0$; $2y = -3x \rightarrow y = -\frac{3}{2}x$
Slope = $-\frac{3}{2}$; y -intercept = 0

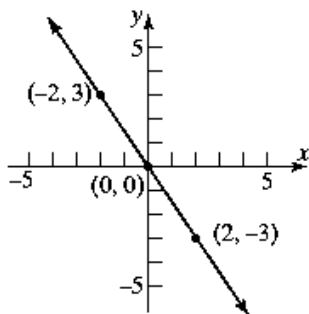

99. a. x -intercept: $2x + 3(0) = 6$
 $2x = 6$
 $x = 3$
The point $(3, 0)$ is on the graph.

y -intercept: $2(0) + 3y = 6$
 $3y = 6$
 $y = 2$

The point $(0, 2)$ is on the graph.

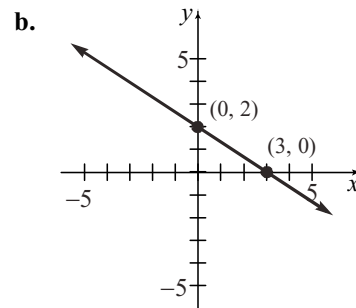

100. a. x -intercept: $3x - 2(0) = 6$
 $3x = 6$
 $x = 2$

The point $(2, 0)$ is on the graph.

y -intercept: $3(0) - 2y = 6$
 $-2y = 6$
 $y = -3$

The point $(0, -3)$ is on the graph.

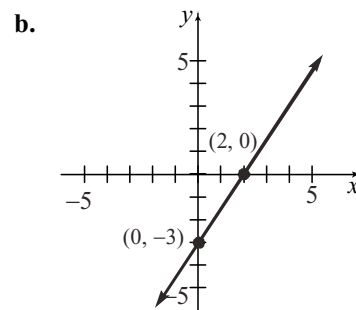

101. a. x -intercept: $-4x + 5(0) = 40$
 $-4x = 40$
 $x = -10$

The point $(-10, 0)$ is on the graph.

y -intercept: $-4(0) + 5y = 40$
 $5y = 40$
 $y = 8$

The point $(0, 8)$ is on the graph.

Chapter 2: Graphs

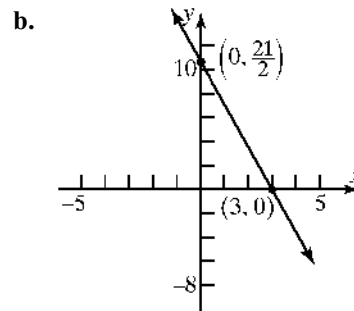
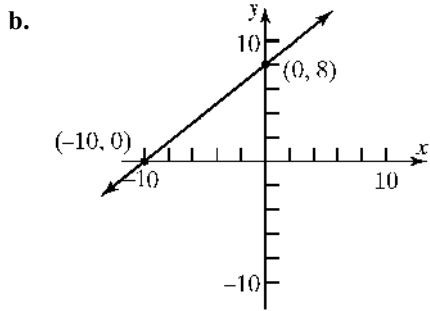

102. a. x -intercept: $6x - 4(0) = 24$
 $6x = 24$
 $x = 4$

The point $(4, 0)$ is on the graph.

y -intercept: $6(0) - 4y = 24$
 $-4y = 24$
 $y = -6$

The point $(0, -6)$ is on the graph.

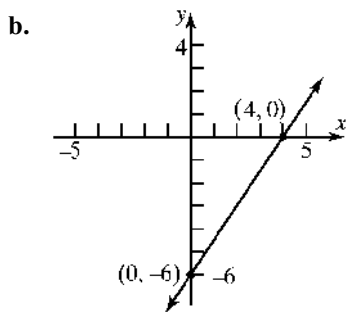

103. a. x -intercept: $7x + 2(0) = 21$
 $7x = 21$
 $x = 3$

The point $(3, 0)$ is on the graph.

y -intercept: $7(0) + 2y = 21$
 $2y = 21$
 $y = \frac{21}{2}$

The point $(0, \frac{21}{2})$ is on the graph.

104. a. x -intercept: $5x + 3(0) = 18$
 $5x = 18$
 $x = \frac{18}{5}$

The point $(\frac{18}{5}, 0)$ is on the graph.

y -intercept: $5(0) + 3y = 18$
 $3y = 18$
 $y = 6$

The point $(0, 6)$ is on the graph.

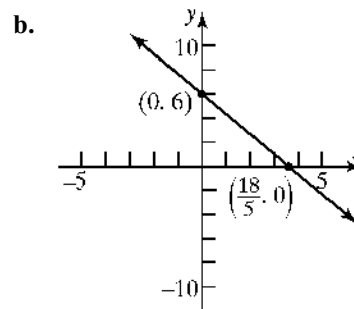

105. a. x -intercept: $\frac{1}{2}x + \frac{1}{3}(0) = 1$
 $\frac{1}{2}x = 1$
 $x = 2$

The point $(2, 0)$ is on the graph.

y -intercept: $\frac{1}{2}(0) + \frac{1}{3}y = 1$
 $\frac{1}{3}y = 1$
 $y = 3$

The point $(0, 3)$ is on the graph.

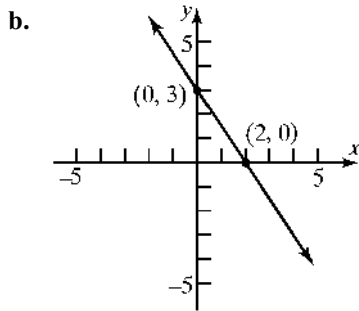

106. a. x -intercept: $x - \frac{2}{3}(0) = 4$
 $x = 4$
 The point (4, 0) is on the graph.

y -intercept: $(0) - \frac{2}{3}y = 4$
 $-\frac{2}{3}y = 4$
 $y = -6$

The point (0, -6) is on the graph.

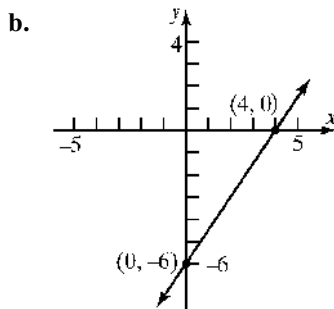

107. a. x -intercept: $0.2x - 0.5(0) = 1$
 $0.2x = 1$
 $x = 5$
 The point (5, 0) is on the graph.

y -intercept: $0.2(0) - 0.5y = 1$
 $-0.5y = 1$
 $y = -2$

The point (0, -2) is on the graph.

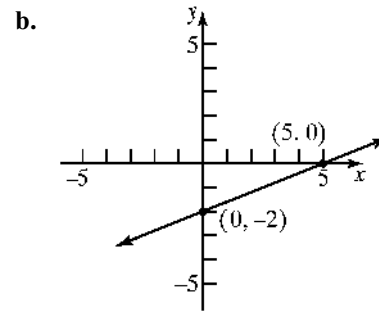

108. a. x -intercept: $-0.3x + 0.4(0) = 1.2$
 $-0.3x = 1.2$
 $x = -4$
 The point (-4, 0) is on the graph.

y -intercept: $-0.3(0) + 0.4y = 1.2$
 $0.4y = 1.2$
 $y = 3$
 The point (0, 3) is on the graph.

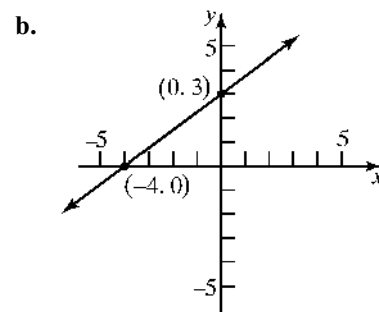

109. The equation of the x -axis is $y = 0$. (The slope is 0 and the y -intercept is 0.)

110. The equation of the y -axis is $x = 0$. (The slope is undefined.)

111. The slopes are the same but the y -intercepts are different. Therefore, the two lines are parallel.

112. The slopes are opposite-reciprocals. That is, their product is -1 . Therefore, the lines are perpendicular.

113. The slopes are different and their product does not equal -1 . Therefore, the lines are neither parallel nor perpendicular.

114. The slopes are different and their product does not equal -1 (in fact, the signs are the same so the product is positive). Therefore, the lines are neither parallel nor perpendicular.

Chapter 2: Graphs

115. Intercepts: $(0, 2)$ and $(-2, 0)$. Thus, slope = 1.
 $y = x + 2$ or $x - y = -2$

116. Intercepts: $(0, 1)$ and $(1, 0)$. Thus, slope = -1 .
 $y = -x + 1$ or $x + y = 1$

117. Intercepts: $(3, 0)$ and $(0, 1)$. Thus, slope = $-\frac{1}{3}$.
 $y = -\frac{1}{3}x + 1$ or $x + 3y = 3$

118. Intercepts: $(0, -1)$ and $(-2, 0)$. Thus,
 slope = $-\frac{1}{2}$.
 $y = -\frac{1}{2}x - 1$ or $x + 2y = -2$

119. $P_1 = (-2, 5)$, $P_2 = (1, 3)$: $m_1 = \frac{5-3}{-2-1} = \frac{2}{-3} = -\frac{2}{3}$
 $P_2 = (1, 3)$, $P_3 = (-1, 0)$: $m_2 = \frac{3-0}{1-(-1)} = \frac{3}{2}$

Since $m_1 \cdot m_2 = -1$, the line segments $\overline{P_1P_2}$ and $\overline{P_2P_3}$ are perpendicular. Thus, the points P_1 , P_2 , and P_3 are vertices of a right triangle.

120. $P_1 = (1, -1)$, $P_2 = (4, 1)$, $P_3 = (2, 2)$, $P_4 = (5, 4)$
 $m_{12} = \frac{1-(-1)}{4-1} = \frac{2}{3}$; $m_{24} = \frac{4-1}{5-4} = 3$;
 $m_{34} = \frac{4-2}{5-2} = \frac{2}{3}$; $m_{13} = \frac{2-(-1)}{2-1} = 3$

Each pair of opposite sides are parallel (same slope) and adjacent sides are not perpendicular. Therefore, the vertices are for a parallelogram.

121. $P_1 = (-1, 0)$, $P_2 = (2, 3)$, $P_3 = (1, -2)$, $P_4 = (4, 1)$
 $m_{12} = \frac{3-0}{2-(-1)} = \frac{3}{3} = 1$; $m_{24} = \frac{1-3}{4-2} = -1$;
 $m_{34} = \frac{1-(-2)}{4-1} = \frac{3}{3} = 1$; $m_{13} = \frac{-2-0}{1-(-1)} = -1$

Opposite sides are parallel (same slope) and adjacent sides are perpendicular (product of slopes is -1). Therefore, the vertices are for a rectangle.

122. $P_1 = (0, 0)$, $P_2 = (1, 3)$, $P_3 = (4, 2)$, $P_4 = (3, -1)$

$$m_{12} = \frac{3-0}{1-0} = 3; \quad m_{23} = \frac{2-3}{4-1} = -\frac{1}{3};$$

$$m_{34} = \frac{-1-2}{3-4} = 3; \quad m_{14} = \frac{-1-0}{3-0} = -\frac{1}{3}$$

$$d_{12} = \sqrt{(1-0)^2 + (3-0)^2} = \sqrt{1+9} = \sqrt{10}$$

$$d_{23} = \sqrt{(4-1)^2 + (2-3)^2} = \sqrt{9+1} = \sqrt{10}$$

$$d_{34} = \sqrt{(3-4)^2 + (-1-2)^2} = \sqrt{1+9} = \sqrt{10}$$

$$d_{14} = \sqrt{(3-0)^2 + (-1-0)^2} = \sqrt{9+1} = \sqrt{10}$$

Opposite sides are parallel (same slope) and adjacent sides are perpendicular (product of slopes is -1). In addition, the length of all four sides is the same. Therefore, the vertices are for a square.

123. Let x = number of miles driven, and let C = cost in dollars.

Total cost = (cost per mile)(number of miles) + fixed cost

$$C = 0.60x + 39$$

$$\text{When } x = 110, C = (0.60)(110) + 39 = \$105.00.$$

$$\text{When } x = 230, C = (0.60)(230) + 39 = \$177.00.$$

124. Let x = number of pairs of jeans manufactured, and let C = cost in dollars.

Total cost = (cost per pair)(number of pairs) + fixed cost

$$C = 20x + 1200$$

$$\text{When } x = 400, C = (20)(400) + 1200 = \$9200.$$

$$\text{When } x = 740, C = (20)(740) + 1200 = \$16,000.$$

125. Let x = number of miles driven annually, and let C = cost in dollars.

Total cost = (approx cost per mile)(number of miles) + fixed cost

$$C = 0.14x + 4252$$

126. Let x = profit in dollars, and let S = salary in dollars.

Weekly salary = (% share of profit)(profit) + weekly pay

$$S = 0.05x + 525$$

127. a. $C = 0.0905x + 8.28$; $0 \leq x \leq 1000$

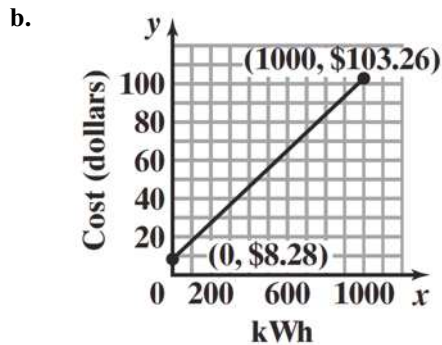

- c. For 200 kWh,
 $C = 0.0905(200) + 8.28 = \26.38
- d. For 500 kWh,
 $C = 0.0905(500) + 8.28 = \53.53
- e. For each usage increase of 1 kWh, the monthly charge increases by \$0.0905 (that is, 9.05 cents).

128. a. $C = 0.623x + 20.26$

- b. For 90 therms,
 $C = 0.623(90) + 20.26 = \76.33
- c. For 150 therms,
 $C = 0.623(150) + 20.26 = \113.71

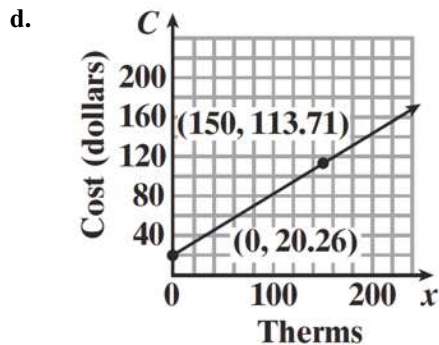

- e. For each usage increase of 1 therm the monthly charge increases by \$0.623 (that is, 62.3 cents).

129. $(^{\circ}C, ^{\circ}F) = (0, 32)$; $(^{\circ}C, ^{\circ}F) = (100, 212)$

$$\text{slope} = \frac{212 - 32}{100 - 0} = \frac{180}{100} = \frac{9}{5}$$

$$^{\circ}F - 32 = \frac{9}{5}(^{\circ}C - 0)$$

$$^{\circ}F - 32 = \frac{9}{5}(^{\circ}C)$$

$$^{\circ}C = \frac{5}{9}(^{\circ}F - 32)$$

If $^{\circ}F = 70$, then

$$^{\circ}C = \frac{5}{9}(70 - 32) = \frac{5}{9}(38)$$

$$^{\circ}C \approx 21.1^{\circ}$$

130. a. $K = ^{\circ}C + 273$

b. $^{\circ}C = \frac{5}{9}(^{\circ}F - 32)$

$$K = \frac{5}{9}(^{\circ}F - 32) + 273$$

$$K = \frac{5}{9}^{\circ}F - \frac{160}{9} + 273$$

$$K = \frac{5}{9}^{\circ}F + \frac{2297}{9}$$

131. a. The y -intercept is $(0, 30)$, so $b = 30$. Since the ramp drops 2 inches for every 25 inches of run, the slope is $m = \frac{-2}{25} = -\frac{2}{25}$. Thus,

the equation is $y = -\frac{2}{25}x + 30$.

- b. Let $y = 0$.

$$0 = -\frac{2}{25}x + 30$$

$$\frac{2}{25}x = 30$$

$$\frac{25}{2}\left(\frac{2}{25}x\right) = \frac{25}{2}(30)$$

$$x = 375$$

The x -intercept is $(375, 0)$. This means that the ramp meets the floor 375 inches (or 31.25 feet) from the base of the platform.

- c. No. From part (b), the run is 31.25 feet which exceeds the required maximum of 30 feet.

- d. First, design requirements state that the maximum slope is a drop of 1 inch for each 12 inches of run. This means $|m| \leq \frac{1}{12}$.

Chapter 2: Graphs

Second, the run is restricted to be no more than 30 feet = 360 inches. For a rise of 30 inches, this means the minimum slope is

$$\frac{30}{360} = \frac{1}{12}. \text{ That is, } |m| \geq \frac{1}{12}. \text{ Thus, the}$$

only possible slope is $|m| = \frac{1}{12}$. The

diagram indicates that the slope is negative. Therefore, the only slope that can be used to obtain the 30-inch rise and still meet design

requirements is $m = -\frac{1}{12}$. In words, for every 12 inches of run, the ramp must drop *exactly* 1 inch.

- 132. a.** Let x represent the percent of internet ad spending. Let y represent the percent of print ad spending. Then the points $(0.19, 0.26)$ and $(0.35, 0.16)$ are on the line.

$$\text{Thus, } m = \frac{16 - 26}{35 - 19} = -\frac{10}{16} = -0.625. \text{ Using}$$

the point-slope formula we have

$$y - 26 = -0.625(x - 19)$$

$$y - 26 = -0.625x + 11.875$$

$$y = -0.625x + 37.875$$

- b.** x -intercept: $0 = -0.625x + 37.875$

$$-37.875 = -0.625x$$

$$60.6 = x$$

$$y\text{-intercept: } y = -0.625(0) + 37.875$$

$$= 37.875$$

The intercepts are $(60.6, 0)$ and $(0, 37.875)$.

- c.** y -intercept: When Internet ads account for 0% of U.S. advertisement spending, print ads account for 37.875% of the spending.
 x -intercept: When Internet ads account for 60.6% of U.S. advertisement spending, print ads account for 0% of the spending.

- d.** Let $x = 39.2$.

$$y = -0.625(39.2) + 37.875 = 13.4\%$$

- 133. a.** Let x = number of boxes to be sold, and A = money, in dollars, spent on advertising. We have the points $(x_1, A_1) = (100,000, 40,000)$;

$$(x_2, A_2) = (200,000, 60,000)$$

$$\text{slope} = \frac{60,000 - 40,000}{200,000 - 100,000}$$

$$= \frac{20,000}{100,000} = \frac{1}{5}$$

$$A - 40,000 = \frac{1}{5}(x - 100,000)$$

$$A - 40,000 = \frac{1}{5}x - 20,000$$

$$A = \frac{1}{5}x + 20,000$$

- b.** If $x = 300,000$, then

$$A = \frac{1}{5}(300,000) + 20,000 = \$80,000$$

- c.** Each additional box sold requires an additional \$0.20 in advertising.

- 134.** $2x - y = C$

Graph the lines:

$$2x - y = -4$$

$$2x - y = 0$$

$$2x - y = 2$$

All the lines have the same slope, 2. The lines are parallel.

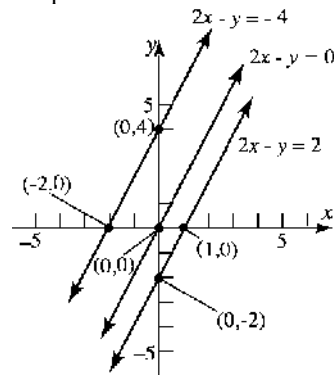

- 135.** Put each linear equation in slope/intercept form.

$$x + 2y = 5 \quad 2x - 3y + 4 = 0 \quad ax + y = 0$$

$$2y = -x + 5 \quad -3y = -2x - 4 \quad y = -ax$$

$$y = -\frac{1}{2}x + \frac{5}{2} \quad y = \frac{2}{3}x + \frac{4}{3}$$

If the slope of $y = -ax$ equals the slope of either of the other two lines, then no triangle is formed.

$$\text{So, } -a = -\frac{1}{2} \Rightarrow a = \frac{1}{2} \text{ and } -a = \frac{2}{3} \Rightarrow a = -\frac{2}{3}.$$

Also if all three lines intersect at a single point,

then no triangle is formed. So, we find where

$$y = -\frac{1}{2}x + \frac{5}{2} \text{ and } y = \frac{2}{3}x + \frac{4}{3} \text{ intersect.}$$

$$-\frac{1}{2}x + \frac{5}{2} = \frac{2}{3}x + \frac{4}{3}$$

$$-\frac{7}{6}x = -\frac{7}{6}$$

$$x = 1$$

$$-\frac{1}{2}(1) + \frac{5}{2} = 2$$

The two lines intersect at (1, 2). If $y = -ax$ also contains the point (1, 2), then

$$2 = -a \cdot 1 \Rightarrow a = -2.$$

The three numbers are $\frac{1}{2}$, $-\frac{2}{3}$, and -2 .

- 136.** The slope of the line containing (a, b) and (b, a) is

$$\frac{a-b}{b-a} = -1$$

The slope of the line $y = x$ is 1.

The two lines are perpendicular.

The midpoint of (a, b) and (b, a) is

$$M = \left(\frac{a+b}{2}, \frac{b+a}{2} \right).$$

Since the x and y coordinates of M are equal, M lies on the line $y = x$.

$$\text{Note: } \frac{a+b}{2} = \frac{b+a}{2}$$

- 137.** The three midpoints are

$$\left(\frac{0+a}{2}, \frac{0+0}{2} \right) = \left(\frac{a}{2}, 0 \right), \left(\frac{a+b}{2}, \frac{0+c}{2} \right) = \left(\frac{a+b}{2}, \frac{c}{2} \right)$$

$$\text{and } \left(\frac{0+b}{2}, \frac{0+c}{2} \right) = \left(\frac{b}{2}, \frac{c}{2} \right).$$

$$\text{Line 1 from } (0,0) \text{ to } \left(\frac{a+b}{2}, \frac{c}{2} \right)$$

$$m = \frac{\frac{c}{2} - 0}{\frac{a+b}{2} - 0} = \frac{c}{a+b};$$

$$y - 0 = \frac{c}{a+b}(x - 0)$$

$$y = \frac{c}{a+b}x_1$$

$$\text{Line 2 from } (a, 0) \text{ to } \left(\frac{b}{2}, \frac{c}{2} \right)$$

$$m = \frac{\frac{c}{2} - 0}{\frac{b}{2} - a} = \frac{\frac{c}{2}}{\frac{b-2a}{2}} = \frac{c}{b-2a}$$

$$y - 0 = \frac{c}{b-2a}(x - a)$$

$$y = \frac{c}{b-2a}(x - a)$$

$$\text{Line 3 from } \left(\frac{a}{2}, 0 \right) \text{ to } (b, c)$$

$$m = \frac{c-0}{b-\frac{a}{2}} = \frac{2c}{2b-a}$$

$$y - 0 = \frac{2c}{2b-a} \left(x - \frac{a}{2} \right)$$

$$y = \frac{2c}{2b-a} \left(x - \frac{a}{2} \right)$$

Find where line 1 and line 2 intersect:

$$\frac{c}{a+b}x = \frac{c}{b-2a}(x-a)$$

$$\frac{b-2a}{a+b}x = x-a$$

$$\frac{b-2a-a-b}{a+b}x = -a$$

$$\frac{-3a}{a+b}x = -a$$

$$x = \frac{a+b}{3};$$

Substitute into line 1:

$$y = \frac{c}{a+b} \cdot \frac{a+b}{3} = \frac{c}{3}.$$

Chapter 2: Graphs

So, line 1 and line 2 intersect at $\left(\frac{a+b}{3}, \frac{c}{3}\right)$.

Show that line 3 contains the point $\left(\frac{a+b}{3}, \frac{c}{3}\right)$:

$$y = \frac{2c}{2b-a} \left(\frac{a+b}{3} - \frac{a}{2} \right) = \frac{2c}{2b-a} \cdot \frac{2b-a}{6} = \frac{c}{3} \text{ So}$$

the three lines intersect at $\left(\frac{a+b}{3}, \frac{c}{3}\right)$.

- 138.** Refer to Figure 43. Assume $m_1 m_2 = -1$. Then

$$\begin{aligned} [d(A, B)]^2 &= (1-1)^2 + (m_1 - m_2)^2 \\ &= (m_1 - m_2)^2 \\ &= m_1^2 - 2m_1 m_2 + m_2^2 \\ &= m_1^2 - 2(-1) + m_2^2 \\ &= m_1^2 + m_2^2 + 2 \end{aligned}$$

Now,

$$\begin{aligned} [d(O, B)]^2 &= (1-0)^2 + (m_1 - 0)^2 = 1 + m_1^2 \\ [d(O, A)]^2 &= (1-0)^2 + (m_2 - 0)^2 = 1 + m_2^2 \end{aligned}$$

So

$$\begin{aligned} [d(O, B)]^2 + [d(O, A)]^2 &= 1 + m_1^2 + 1 + m_2^2 \\ &= m_1^2 + m_2^2 + 2 = [d(A, B)]^2 \end{aligned}$$

By the converse of the Pythagorean Theorem, $\triangle AOB$ is a right triangle with right angle at vertex O . Thus lines OA and OB are perpendicular.

- 139.** (b), (c), (e) and (g)
The line has positive slope and positive y -intercept.
- 140.** (a), (c), and (g)
The line has negative slope and positive y -intercept.
- 141.** (c)
The equation $x - y = -2$ has slope 1 and y -intercept (0, 2). The equation $x - y = 1$ has slope 1 and y -intercept (0, -1). Thus, the lines are parallel with positive slopes. One line has a positive y -intercept and the other with a negative y -intercept.

- 142.** (d)
The equation $y - 2x = 2$ has slope 2 and y -intercept (0, 2). The equation $x + 2y = -1$ has slope $-\frac{1}{2}$ and y -intercept $\left(0, -\frac{1}{2}\right)$. The lines are perpendicular since $2\left(-\frac{1}{2}\right) = -1$. One line has a positive y -intercept and the other with a negative y -intercept.

143 – 145. Answers will vary.

- 146.** No, the equation of a vertical line cannot be written in slope-intercept form because the slope is undefined.

- 147.** No, a line does not need to have both an x -intercept and a y -intercept. Vertical and horizontal lines have only one intercept (unless they are a coordinate axis). Every line must have at least one intercept.

- 148.** Two lines with equal slopes and equal y -intercepts are coinciding lines (i.e. the same).

- 149.** Two lines that have the same x -intercept and y -intercept (assuming the x -intercept is not 0) are the same line since a line is uniquely defined by two distinct points.

- 150.** No. Two lines with the same slope and different x -intercepts are distinct parallel lines and have no points in common.

Assume Line 1 has equation $y = mx + b_1$ and Line 2 has equation $y = mx + b_2$,

Line 1 has x -intercept $-\frac{b_1}{m}$ and y -intercept b_1 .

Line 2 has x -intercept $-\frac{b_2}{m}$ and y -intercept b_2 .

Assume also that Line 1 and Line 2 have unequal x -intercepts.

If the lines have the same y -intercept, then $b_1 = b_2$.

$$b_1 = b_2 \Rightarrow \frac{b_1}{m} = \frac{b_2}{m} \Rightarrow -\frac{b_1}{m} = -\frac{b_2}{m}$$

But $-\frac{b_1}{m} = -\frac{b_2}{m} \Rightarrow$ Line 1 and Line 2 have the

same x -intercept, which contradicts the original assumption that the lines have unequal x -intercepts. Therefore, Line 1 and Line 2 cannot have the same y -intercept.

151. Yes. Two distinct lines with the same y -intercept, but different slopes, can have the same x -intercept if the x -intercept is $x = 0$.

Assume Line 1 has equation $y = m_1x + b$ and Line 2 has equation $y = m_2x + b$,

Line 1 has x -intercept $-\frac{b}{m_1}$ and y -intercept b .

Line 2 has x -intercept $-\frac{b}{m_2}$ and y -intercept b .

Assume also that Line 1 and Line 2 have unequal slopes, that is $m_1 \neq m_2$.

If the lines have the same x -intercept, then

$$-\frac{b}{m_1} = -\frac{b}{m_2}.$$

$$-\frac{b}{m_1} = -\frac{b}{m_2}$$

$$-m_2b = -m_1b$$

$$-m_2b + m_1b = 0$$

$$\text{But } -m_2b + m_1b = 0 \Rightarrow b(m_1 - m_2) = 0$$

$$\Rightarrow b = 0$$

$$\text{or } m_1 - m_2 = 0 \Rightarrow m_1 = m_2$$

Since we are assuming that $m_1 \neq m_2$, the only way that the two lines can have the same x -intercept is if $b = 0$.

152. Answers will vary.

$$153. m = \frac{y_2 - y_1}{x_2 - x_1} = \frac{-4 - 2}{1 - (-3)} = \frac{-6}{4} = -\frac{3}{2}$$

It appears that the student incorrectly found the slope by switching the direction of one of the subtractions.

$$154. \left(\frac{x^2y^{-3}}{x^4y^5}\right)^{-2} = \left(\frac{x^2}{x^4y^5y^3}\right)^{-2}$$

$$= \left(\frac{1}{x^2y^8}\right)^{-2}$$

$$= \left(\frac{x^2y^8}{1}\right)^2 = x^4y^{16}$$

$$155. h^2 = a^2 + b^2$$

$$= 8^2 + 15^2$$

$$= 16 + 225$$

$$= 289$$

$$h = \sqrt{289} = 17$$

$$156. (x-3)^2 + 25 = 49$$

$$(x-3)^2 = 24$$

$$x-3 = \pm\sqrt{24}$$

$$x-3 = \pm 2\sqrt{6}$$

$$x = 3 \pm 2\sqrt{6}$$

The solution set is: $\{3 - 2\sqrt{6}, 3 + 2\sqrt{6}\}$.

$$157. |2x-5| + 7 < 10$$

$$|2x-5| < 3$$

$$-3 < 2x-5 < 3$$

$$2 < 2x < 8$$

$$1 < x < 4$$

The solution set is: $\{x \mid 1 < x < 4\}$.

Interval notation: $(1, 4)$

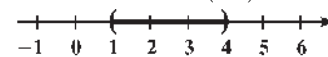

158. The radicand must be greater than or equal to 0 so:

$$8 - \frac{2}{3}x \geq 0$$

$$-\frac{2}{3}x \geq -8$$

$$x \leq -8\left(-\frac{3}{2}\right)$$

$$x \leq 12$$

The solution set is: $\{x \mid x \leq 12\}$.

Interval notation: $(-\infty, 12]$

Chapter 2: Graphs

159. $\left(\frac{1}{2} \cdot \frac{3}{4}\right)^2 = \left(\frac{3}{8}\right)^2 = \frac{9}{64}$

160. $\frac{x^2-16}{x^2+6x+8} \cdot \frac{x+2}{16-4x} = \frac{(x-4)(x+4)}{(x+2)(x+4)} \cdot \frac{x+2}{4(4-x)}$
 $= \frac{(x-4)}{4(4-x)} = -\frac{1}{4}$

161. $\frac{\sqrt{x+1}+\sqrt{x}}{\sqrt{x+1}-\sqrt{x}} \cdot \frac{\sqrt{x+1}+\sqrt{x}}{\sqrt{x+1}+\sqrt{x}} =$
 $\frac{(\sqrt{x+1})^2 + 2\sqrt{x+1}\sqrt{x} + (\sqrt{x})^2}{(\sqrt{x+1})^2 - (\sqrt{x})^2} =$
 $\frac{x+1+2\sqrt{x+1}\sqrt{x}+x}{x+1-x} = x+1+2\sqrt{x+1}\sqrt{x}+x =$
 $2x+1+2\sqrt{x(x+1)}$

162. $x-5\sqrt{x}+6=0$
 $(\sqrt{x}-3)(\sqrt{x}-2)=0$
 $\sqrt{x}-3=0$ or $\sqrt{x}-2=0$
 $\sqrt{x}=3$ or $\sqrt{x}=2$
 $x=9$ or $x=4$
 The solution set is $\{4, 9\}$.

Section 2.4

1. add; $\left(\frac{1}{2} \cdot 10\right)^2 = 25$

2. $(x-2)^2 = 9$
 $x-2 = \pm\sqrt{9}$
 $x-2 = \pm 3$
 $x = 2 \pm 3$
 $x = 5$ or $x = -1$
 The solution set is $\{-1, 5\}$.

3. a. Center: $(0,0)$; radius 1; $x^2 + y^2 = 1$
 b. $x^2 + y^2 = 9$
 c. $x^2 + y^2 = 25$
 d. Center: $(2,1)$; $(x-2)^2 + (y-1)^2 = 1$

e. Center: $(-2,1)$; $(x+2)^2 + (y-1)^2 = 1$

f. Center: $(-2,-2)$; $(x+2)^2 + (y+2)^2 = 1$

g. Center: $(5,-7)$; radius 6

4. a. Center: $(4,0)$; $(x-4)^2 + y^2 = 9$; No y -intercepts; x -intercepts: 4,7
 b. Center: $(4,-3)$; $(x-4)^2 + (y+3)^2 = 9$; No y -intercepts; x -intercepts: 4
 c. $(x-4)^2 + (y+4)^2 = 9$; No y -intercepts; No x -intercepts
 d. One x -intercept
 e. No y -intercepts
5. False. For example, $x^2 + y^2 + 2x + 2y + 8 = 0$ is not a circle. It has no real solutions.
6. radius
7. True; $r^2 = 9 \rightarrow r = 3$
8. False; the center of the circle $(x+3)^2 + (y-2)^2 = 13$ is $(-3,2)$.

9. d
 10. a

11. Center = $(2, 1)$
 Radius = distance from $(0,1)$ to $(2,1)$
 $= \sqrt{(2-0)^2 + (1-1)^2} = \sqrt{4} = 2$
 Equation: $(x-2)^2 + (y-1)^2 = 4$

12. Center = $(1, 2)$
 Radius = distance from $(1,0)$ to $(1,2)$
 $= \sqrt{(1-1)^2 + (2-0)^2} = \sqrt{4} = 2$
 Equation: $(x-1)^2 + (y-2)^2 = 4$

13. Center = midpoint of $(1, 2)$ and $(4, 2)$
 $= \left(\frac{1+4}{2}, \frac{2+2}{2}\right) = \left(\frac{5}{2}, 2\right)$

Radius = distance from $(\frac{5}{2}, 2)$ to $(4, 2)$

$$= \sqrt{\left(4 - \frac{5}{2}\right)^2 + (2 - 2)^2} = \sqrt{\frac{9}{4}} = \frac{3}{2}$$

Equation: $\left(x - \frac{5}{2}\right)^2 + (y - 2)^2 = \frac{9}{4}$

14. Center = midpoint of $(0, 1)$ and $(2, 3)$

$$= \left(\frac{0+2}{2}, \frac{1+3}{2}\right) = (1, 2)$$

Radius = distance from $(1, 2)$ to $(2, 3)$

$$= \sqrt{(2-1)^2 + (3-2)^2} = \sqrt{2}$$

Equation: $(x-1)^2 + (y-2)^2 = 2$

15. $(x-h)^2 + (y-k)^2 = r^2$

$$(x-0)^2 + (y-0)^2 = 2^2$$

$$x^2 + y^2 = 4$$

General form: $x^2 + y^2 - 4 = 0$

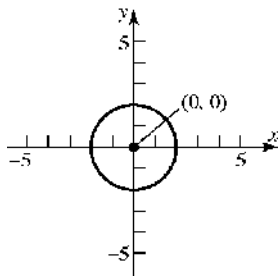

16. $(x-h)^2 + (y-k)^2 = r^2$

$$(x-0)^2 + (y-0)^2 = 3^2$$

$$x^2 + y^2 = 9$$

General form: $x^2 + y^2 - 9 = 0$

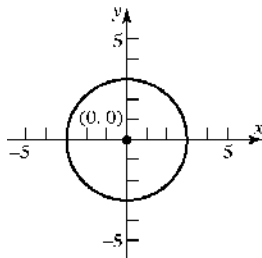

17. $(x-h)^2 + (y-k)^2 = r^2$

$$(x-0)^2 + (y-2)^2 = 2^2$$

$$x^2 + (y-2)^2 = 4$$

General form: $x^2 + y^2 - 4y + 4 = 4$

$$x^2 + y^2 - 4y = 0$$

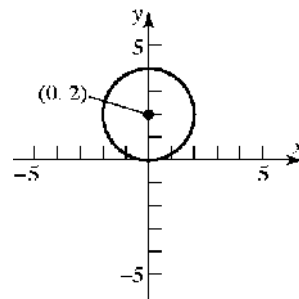

18. $(x-h)^2 + (y-k)^2 = r^2$

$$(x-1)^2 + (y-0)^2 = 3^2$$

$$(x-1)^2 + y^2 = 9$$

General form: $x^2 - 2x + 1 + y^2 = 9$

$$x^2 + y^2 - 2x - 8 = 0$$

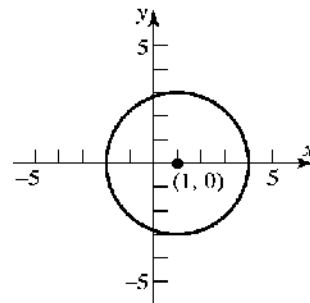

19. $(x-h)^2 + (y-k)^2 = r^2$

$$(x-4)^2 + (y-(-3))^2 = 5^2$$

$$(x-4)^2 + (y+3)^2 = 25$$

General form:

$$x^2 - 8x + 16 + y^2 + 6y + 9 = 25$$

$$x^2 + y^2 - 8x + 6y = 0$$

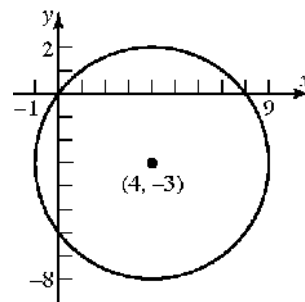

Chapter 2: Graphs

20. $(x-h)^2 + (y-k)^2 = r^2$

$$(x-2)^2 + (y-(-3))^2 = 4^2$$

$$(x-2)^2 + (y+3)^2 = 16$$

General form: $x^2 - 4x + 4 + y^2 + 6y + 9 = 16$

$$x^2 + y^2 - 4x + 6y - 3 = 0$$

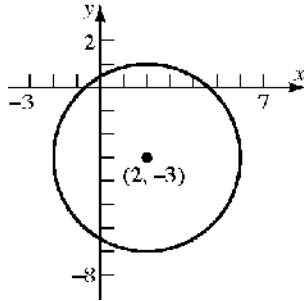

21. $(x-h)^2 + (y-k)^2 = r^2$

$$(x-(-2))^2 + (y-1)^2 = 4^2$$

$$(x+2)^2 + (y-1)^2 = 16$$

General form: $x^2 + 4x + 4 + y^2 - 2y + 1 = 16$

$$x^2 + y^2 + 4x - 2y - 11 = 0$$

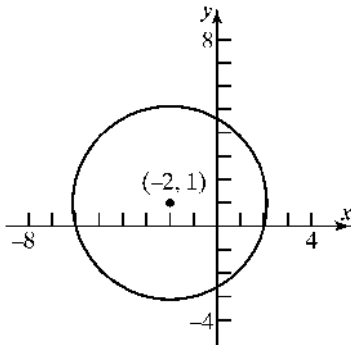

22. $(x-h)^2 + (y-k)^2 = r^2$

$$(x-(-5))^2 + (y-(-2))^2 = 7^2$$

$$(x+5)^2 + (y+2)^2 = 49$$

General form: $x^2 + 10x + 25 + y^2 + 4y + 4 = 49$

$$x^2 + y^2 + 10x + 4y - 20 = 0$$

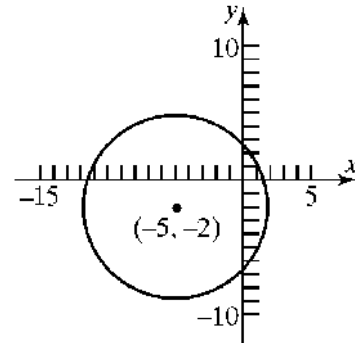

23. $(x-h)^2 + (y-k)^2 = r^2$

$$\left(x - \frac{1}{2}\right)^2 + (y-0)^2 = \left(\frac{1}{2}\right)^2$$

$$\left(x - \frac{1}{2}\right)^2 + y^2 = \frac{1}{4}$$

General form: $x^2 - x + \frac{1}{4} + y^2 = \frac{1}{4}$

$$x^2 + y^2 - x = 0$$

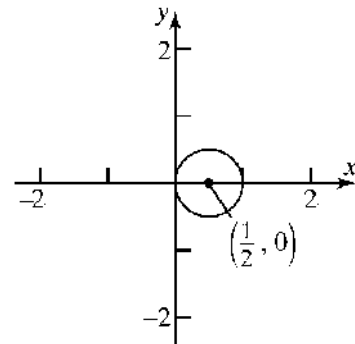

24. $(x-h)^2 + (y-k)^2 = r^2$

$$(x-0)^2 + \left(y - \left(-\frac{1}{2}\right)\right)^2 = \left(\frac{1}{2}\right)^2$$

$$x^2 + \left(y + \frac{1}{2}\right)^2 = \frac{1}{4}$$

Section 2.4: Circles

General form: $x^2 + y^2 + y + \frac{1}{4} = \frac{1}{4}$
 $x^2 + y^2 + y = 0$

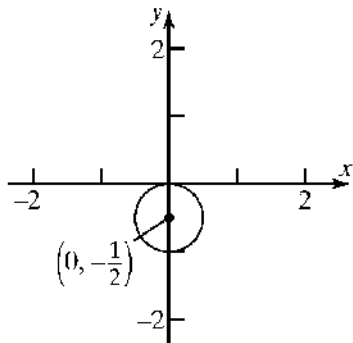

25. $(x-h)^2 + (y-k)^2 = r^2$
 $(x-5)^2 + (y-(-1))^2 = (\sqrt{13})^2$
 $(x-5)^2 + (y+1)^2 = 13$
 General form:
 $x^2 - 10x + 25 + y^2 + 2y + 1 = 13$
 $x^2 + y^2 - 10x + 2y + 13 = 0$

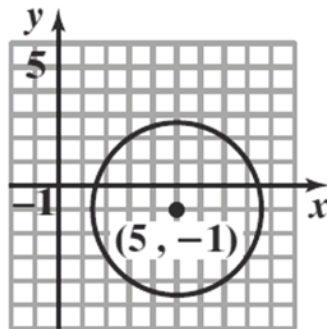

26. $(x-h)^2 + (y-k)^2 = r^2$
 $(x-(-3))^2 + (y-2)^2 = (2\sqrt{5})^2$
 $(x+3)^2 + (y-2)^2 = 20$

General form: $x^2 + 6x + 9 + y^2 - 4y + 4 = 20$
 $x^2 + y^2 + 6x - 4y - 7 = 0$

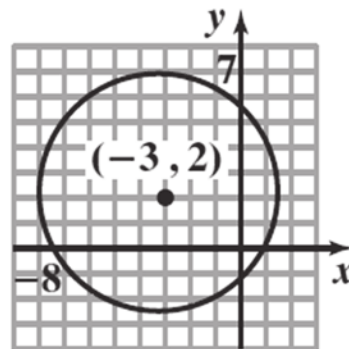

27. $x^2 + y^2 = 4$
 $x^2 + y^2 = 2^2$
 a. Center: (0,0); Radius = 2

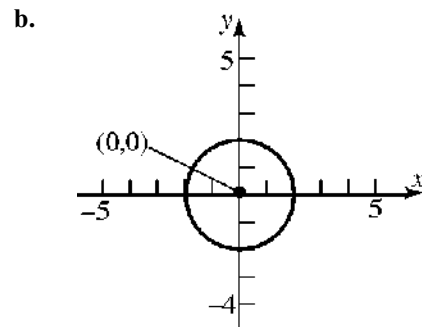

c. x -intercepts: $x^2 + (0)^2 = 4$
 $x^2 = 4$
 $x = \pm\sqrt{4} = \pm 2$
 y -intercepts: $(0)^2 + y^2 = 4$
 $y^2 = 4$
 $y = \pm\sqrt{4} = \pm 2$
 The intercepts are $(-2, 0)$, $(2, 0)$, $(0, -2)$, and $(0, 2)$.

28. $x^2 + (y-1)^2 = 1$
 $x^2 + (y-1)^2 = 1^2$
 a. Center:(0, 1); Radius = 1

Chapter 2: Graphs

b.

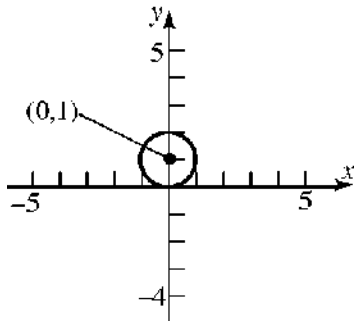

c. x-intercepts: $x^2 + (0-1)^2 = 1$

$$x^2 + 1 = 1$$

$$x^2 = 0$$

$$x = \pm\sqrt{0} = 0$$

y-intercepts: $(0)^2 + (y-1)^2 = 1$

$$(y-1)^2 = 1$$

$$y-1 = \pm\sqrt{1}$$

$$y-1 = \pm 1$$

$$y = 1 \pm 1$$

$$y = 2 \text{ or } y = 0$$

The intercepts are (0, 0) and (0, 2).

29. $2(x-3)^2 + 2y^2 = 8$

$$(x-3)^2 + y^2 = 4$$

a. Center: (3, 0); Radius = 2

b.

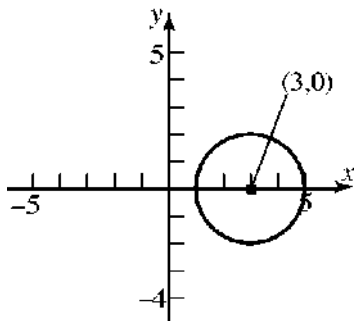

c. x-intercepts: $(x-3)^2 + (0)^2 = 4$

$$(x-3)^2 = 4$$

$$x-3 = \pm\sqrt{4}$$

$$x-3 = \pm 2$$

$$x = 3 \pm 2$$

$$x = 5 \text{ or } x = 1$$

y-intercepts: $(0-3)^2 + y^2 = 4$

$$(-3)^2 + y^2 = 4$$

$$9 + y^2 = 4$$

$$y^2 = -5$$

No real solution.

The intercepts are (1, 0) and (5, 0).

30. $3(x+1)^2 + 3(y-1)^2 = 6$

$$(x+1)^2 + (y-1)^2 = 2$$

a. Center: (-1, 1); Radius = $\sqrt{2}$

b.

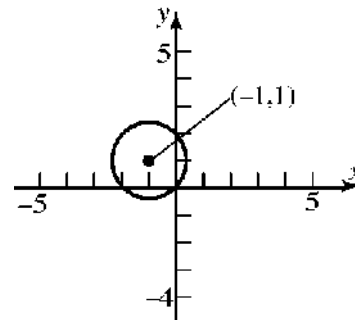

c. x-intercepts: $(x+1)^2 + (0-1)^2 = 2$

$$(x+1)^2 + (-1)^2 = 2$$

$$(x+1)^2 + 1 = 2$$

$$(x+1)^2 = 1$$

$$x+1 = \pm\sqrt{1}$$

$$x+1 = \pm 1$$

$$x = -1 \pm 1$$

$$x = 0 \text{ or } x = -2$$

y-intercepts: $(0+1)^2 + (y-1)^2 = 2$

$$(1)^2 + (y-1)^2 = 2$$

$$1 + (y-1)^2 = 2$$

$$(y-1)^2 = 1$$

$$y-1 = \pm\sqrt{1}$$

$$y-1 = \pm 1$$

$$y = 1 \pm 1$$

$$y = 2 \text{ or } y = 0$$

The intercepts are (-2, 0), (0, 0), and (0, 2).

31. $x^2 + y^2 - 2x - 4y - 4 = 0$

$$x^2 - 2x + y^2 - 4y = 4$$

$$(x^2 - 2x + 1) + (y^2 - 4y + 4) = 4 + 1 + 4$$

$$(x-1)^2 + (y-2)^2 = 3^2$$

a. Center: (1, 2); Radius = 3

b.

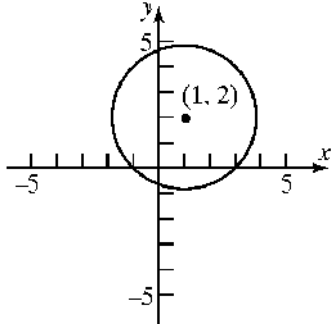

c. x-intercepts: $(x-1)^2 + (0-2)^2 = 3^2$

$$(x-1)^2 + (-2)^2 = 3^2$$

$$(x-1)^2 + 4 = 9$$

$$(x-1)^2 = 5$$

$$x-1 = \pm\sqrt{5}$$

$$x = 1 \pm \sqrt{5}$$

y-intercepts: $(0-1)^2 + (y-2)^2 = 3^2$

$$(-1)^2 + (y-2)^2 = 3^2$$

$$1 + (y-2)^2 = 9$$

$$(y-2)^2 = 8$$

$$y-2 = \pm\sqrt{8}$$

$$y-2 = \pm 2\sqrt{2}$$

$$y = 2 \pm 2\sqrt{2}$$

The intercepts are $(1-\sqrt{5}, 0)$, $(1+\sqrt{5}, 0)$, $(0, 2-2\sqrt{2})$, and $(0, 2+2\sqrt{2})$.

32. $x^2 + y^2 + 4x + 2y - 20 = 0$

$$x^2 + 4x + y^2 + 2y = 20$$

$$(x^2 + 4x + 4) + (y^2 + 2y + 1) = 20 + 4 + 1$$

$$(x+2)^2 + (y+1)^2 = 5^2$$

a. Center: (-2, -1); Radius = 5

b.

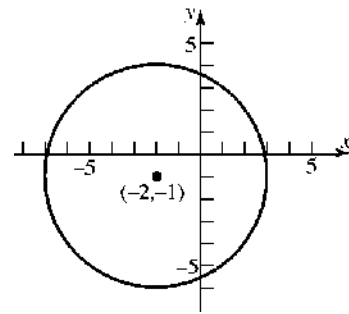

c. x-intercepts: $(x+2)^2 + (0+1)^2 = 5^2$

$$(x+2)^2 + 1 = 25$$

$$(x+2)^2 = 24$$

$$x+2 = \pm\sqrt{24}$$

$$x+2 = \pm 2\sqrt{6}$$

$$x = -2 \pm 2\sqrt{6}$$

y-intercepts: $(0+2)^2 + (y+1)^2 = 5^2$

$$4 + (y+1)^2 = 25$$

$$(y+1)^2 = 21$$

$$y+1 = \pm\sqrt{21}$$

$$y = -1 \pm \sqrt{21}$$

The intercepts are $(-2-2\sqrt{6}, 0)$,

$(-2+2\sqrt{6}, 0)$, $(0, -1-\sqrt{21})$, and

$(0, -1+\sqrt{21})$.

33.

$$x^2 + y^2 + 4x - 4y - 1 = 0$$

$$x^2 + 4x + y^2 - 4y = 1$$

$$(x^2 + 4x + 4) + (y^2 - 4y + 4) = 1 + 4 + 4$$

$$(x+2)^2 + (y-2)^2 = 3^2$$

a. Center: (-2, 2); Radius = 3

b.

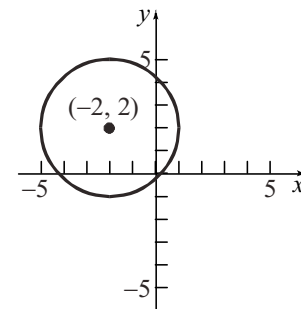

Chapter 2: Graphs

c. x -intercepts: $(x+2)^2 + (0-2)^2 = 3^2$
 $(x+2)^2 + 4 = 9$
 $(x+2)^2 = 5$
 $x+2 = \pm\sqrt{5}$
 $x = -2 \pm \sqrt{5}$

y -intercepts: $(0+2)^2 + (y-2)^2 = 3^2$
 $4 + (y-2)^2 = 9$
 $(y-2)^2 = 5$
 $y-2 = \pm\sqrt{5}$
 $y = 2 \pm \sqrt{5}$

The intercepts are $(-2-\sqrt{5}, 0)$,
 $(-2+\sqrt{5}, 0)$, $(0, 2-\sqrt{5})$, and $(0, 2+\sqrt{5})$.

34. $x^2 + y^2 - 6x + 2y + 9 = 0$
 $x^2 - 6x + y^2 + 2y = -9$
 $(x^2 - 6x + 9) + (y^2 + 2y + 1) = -9 + 9 + 1$
 $(x-3)^2 + (y+1)^2 = 1^2$

a. Center: $(3, -1)$; Radius = 1

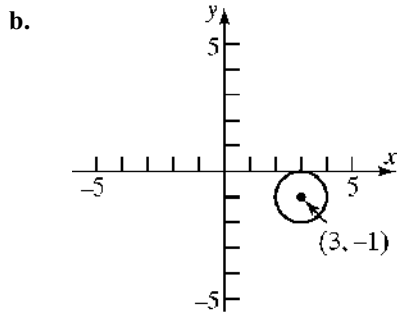

c. x -intercepts: $(x-3)^2 + (0+1)^2 = 1^2$
 $(x-3)^2 + 1 = 1$
 $(x-3)^2 = 0$
 $x-3 = 0$
 $x = 3$

y -intercepts: $(0-3)^2 + (y+1)^2 = 1^2$
 $9 + (y+1)^2 = 1$
 $(y+1)^2 = -8$
 No real solution.

The intercept only intercept is $(3, 0)$.

35. $x^2 + y^2 - x + 2y + 1 = 0$
 $x^2 - x + y^2 + 2y = -1$
 $\left(x^2 - x + \frac{1}{4}\right) + (y^2 + 2y + 1) = -1 + \frac{1}{4} + 1$
 $\left(x - \frac{1}{2}\right)^2 + (y+1)^2 = \left(\frac{1}{2}\right)^2$

a. Center: $\left(\frac{1}{2}, -1\right)$; Radius = $\frac{1}{2}$

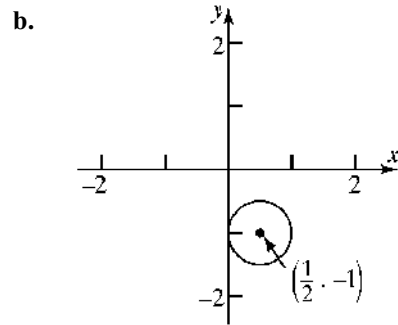

c. x -intercepts: $\left(x - \frac{1}{2}\right)^2 + (0+1)^2 = \left(\frac{1}{2}\right)^2$
 $\left(x - \frac{1}{2}\right)^2 + 1 = \frac{1}{4}$

$$\left(x - \frac{1}{2}\right)^2 = -\frac{3}{4}$$

No real solutions

y -intercepts: $\left(0 - \frac{1}{2}\right)^2 + (y+1)^2 = \left(\frac{1}{2}\right)^2$
 $\frac{1}{4} + (y+1)^2 = \frac{1}{4}$
 $(y+1)^2 = 0$
 $y+1 = 0$
 $y = -1$

The only intercept is $(0, -1)$.

36. $x^2 + y^2 + x + y - \frac{1}{2} = 0$
 $x^2 + x + y^2 + y = \frac{1}{2}$
 $\left(x^2 + x + \frac{1}{4}\right) + \left(y^2 + y + \frac{1}{4}\right) = \frac{1}{2} + \frac{1}{4} + \frac{1}{4}$
 $\left(x + \frac{1}{2}\right)^2 + \left(y + \frac{1}{2}\right)^2 = 1^2$

a. Center: $\left(-\frac{1}{2}, -\frac{1}{2}\right)$; Radius = 1

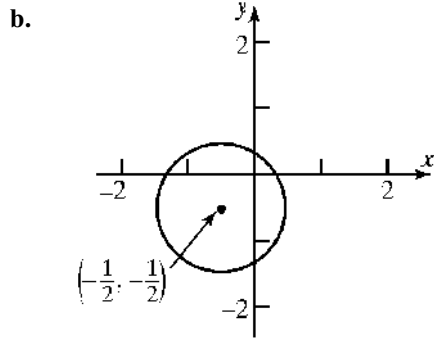

c. x-intercepts: $\left(x + \frac{1}{2}\right)^2 + \left(0 + \frac{1}{2}\right)^2 = 1^2$

$$\left(x + \frac{1}{2}\right)^2 + \frac{1}{4} = 1$$

$$\left(x + \frac{1}{2}\right)^2 = \frac{3}{4}$$

$$x + \frac{1}{2} = \pm \frac{\sqrt{3}}{2}$$

$$x = \frac{-1 \pm \sqrt{3}}{2}$$

y-intercepts: $\left(0 + \frac{1}{2}\right)^2 + \left(y + \frac{1}{2}\right)^2 = 1^2$

$$\frac{1}{4} + \left(y + \frac{1}{2}\right)^2 = 1$$

$$\left(y + \frac{1}{2}\right)^2 = \frac{3}{4}$$

$$y + \frac{1}{2} = \pm \frac{\sqrt{3}}{2}$$

$$y = \frac{-1 \pm \sqrt{3}}{2}$$

The intercepts are $\left(\frac{-1 - \sqrt{3}}{2}, 0\right)$, $\left(\frac{-1 + \sqrt{3}}{2}, 0\right)$,
 $\left(0, \frac{-1 - \sqrt{3}}{2}\right)$, and $\left(0, \frac{-1 + \sqrt{3}}{2}\right)$.

37. $2x^2 + 2y^2 - 12x + 8y - 24 = 0$

$$x^2 + y^2 - 6x + 4y = 12$$

$$x^2 - 6x + y^2 + 4y = 12$$

$$(x^2 - 6x + 9) + (y^2 + 4y + 4) = 12 + 9 + 4$$

$$(x - 3)^2 + (y + 2)^2 = 5^2$$

a. Center: $(3, -2)$; Radius = 5

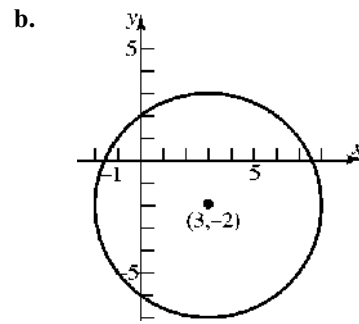

c. x-intercepts: $(x - 3)^2 + (0 + 2)^2 = 5^2$

$$(x - 3)^2 + 4 = 25$$

$$(x - 3)^2 = 21$$

$$x - 3 = \pm \sqrt{21}$$

$$x = 3 \pm \sqrt{21}$$

y-intercepts: $(0 - 3)^2 + (y + 2)^2 = 5^2$

$$9 + (y + 2)^2 = 25$$

$$(y + 2)^2 = 16$$

$$y + 2 = \pm 4$$

$$y = -2 \pm 4$$

$$y = 2 \text{ or } y = -6$$

The intercepts are $(3 - \sqrt{21}, 0)$, $(3 + \sqrt{21}, 0)$,
 $(0, -6)$, and $(0, 2)$.

38. a. $2x^2 + 2y^2 + 8x + 7 = 0$

$$2x^2 + 8x + 2y^2 = -7$$

$$x^2 + 4x + y^2 = -\frac{7}{2}$$

$$(x^2 + 4x + 4) + y^2 = -\frac{7}{2} + 4$$

$$(x + 2)^2 + y^2 = \frac{1}{2}$$

$$(x + 2)^2 + y^2 = \left(\frac{\sqrt{2}}{2}\right)^2$$

Center: $(-2, 0)$; Radius = $\frac{\sqrt{2}}{2}$

Chapter 2: Graphs

b.

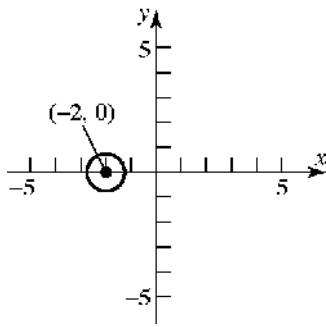

c. x-intercepts: $(x+2)^2 + (0)^2 = \frac{1}{2}$

$$(x+2)^2 = \frac{1}{2}$$

$$x+2 = \pm\sqrt{\frac{1}{2}}$$

$$x+2 = \pm\frac{\sqrt{2}}{2}$$

$$x = -2 \pm \frac{\sqrt{2}}{2}$$

y-intercepts: $(0+2)^2 + y^2 = \frac{1}{2}$

$$4 + y^2 = \frac{1}{2}$$

$$y^2 = -\frac{7}{2}$$

No real solutions.

The intercepts are $\left(-2 - \frac{\sqrt{2}}{2}, 0\right)$ and

$\left(-2 + \frac{\sqrt{2}}{2}, 0\right)$.

39. $2x^2 + 8x + 2y^2 = 0$

$$x^2 + 4x + y^2 = 0$$

$$x^2 + 4x + 4 + y^2 = 0 + 4$$

$$(x+2)^2 + y^2 = 2^2$$

a. Center: $(-2, 0)$; Radius: $r = 2$

b.

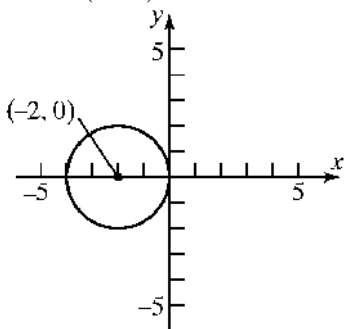

c. x-intercepts: $(x+2)^2 + (0)^2 = 2^2$

$$(x+2)^2 = 4$$

$$(x+2)^2 = \pm\sqrt{4}$$

$$x+2 = \pm 2$$

$$x = -2 \pm 2$$

$$x = 0 \text{ or } x = -4$$

y-intercepts: $(0+2)^2 + y^2 = 2^2$

$$4 + y^2 = 4$$

$$y^2 = 0$$

$$y = 0$$

The intercepts are $(-4, 0)$ and $(0, 0)$.

40. $3x^2 + 3y^2 - 12y = 0$

$$x^2 + y^2 - 4y = 0$$

$$x^2 + y^2 - 4y + 4 = 0 + 4$$

$$x^2 + (y-2)^2 = 4$$

a. Center: $(0, 2)$; Radius: $r = 2$

b.

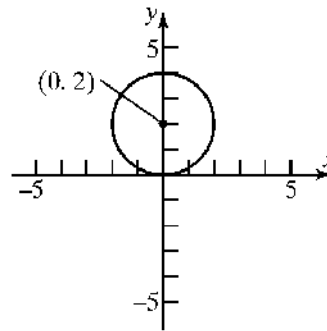

c. x-intercepts: $x^2 + (0-2)^2 = 4$

$$x^2 + 4 = 4$$

$$x^2 = 0$$

$$x = 0$$

y-intercepts: $0^2 + (y-2)^2 = 4$

$$(y-2)^2 = 4$$

$$y-2 = \pm\sqrt{4}$$

$$y-2 = \pm 2$$

$$y = 2 \pm 2$$

$$y = 4 \text{ or } y = 0$$

The intercepts are $(0, 0)$ and $(0, 4)$.

41. Center at (0, 0); containing point (-2, 3).

$$r = \sqrt{(-2-0)^2 + (3-0)^2} = \sqrt{4+9} = \sqrt{13}$$

$$\text{Equation: } (x-0)^2 + (y-0)^2 = (\sqrt{13})^2$$

$$x^2 + y^2 = 13$$

42. Center at (1, 0); containing point (-3, 2).

$$r = \sqrt{(-3-1)^2 + (2-0)^2} = \sqrt{16+4} = \sqrt{20} = 2\sqrt{5}$$

$$\text{Equation: } (x-1)^2 + (y-0)^2 = (\sqrt{20})^2$$

$$(x-1)^2 + y^2 = 20$$

43. Endpoints of a diameter are (1, 4) and (-3, 2).

The center is at the midpoint of that diameter:

$$\text{Center: } \left(\frac{1+(-3)}{2}, \frac{4+2}{2} \right) = (-1, 3)$$

$$\text{Radius: } r = \sqrt{(1-(-1))^2 + (4-3)^2} = \sqrt{4+1} = \sqrt{5}$$

$$\text{Equation: } (x-(-1))^2 + (y-3)^2 = (\sqrt{5})^2$$

$$(x+1)^2 + (y-3)^2 = 5$$

44. Endpoints of a diameter are (4, 3) and (0, 1).

The center is at the midpoint of that diameter:

$$\text{Center: } \left(\frac{4+0}{2}, \frac{3+1}{2} \right) = (2, 2)$$

$$\text{Radius: } r = \sqrt{(4-2)^2 + (3-2)^2} = \sqrt{4+1} = \sqrt{5}$$

$$\text{Equation: } (x-2)^2 + (y-2)^2 = (\sqrt{5})^2$$

$$(x-2)^2 + (y-2)^2 = 5$$

- 45.
- $C = 2\pi r$

$$16\pi = 2\pi r$$

$$r = 8$$

$$(x-2)^2 + (y-(-4))^2 = (8)^2$$

$$(x-2)^2 + (y+4)^2 = 64$$

- 46.
- $A = \pi r^2$

$$49\pi = \pi r^2$$

$$r = 7$$

$$(x-(-5))^2 + (y-6)^2 = (7)^2$$

$$(x+5)^2 + (y-6)^2 = 49$$

47. (c); Center: (1, -2); Radius = 2

48. (d); Center: (-3, 3); Radius = 3

49. (b); Center: (-1, 2); Radius = 2

50. (a); Center: (3, -3); Radius = 3

51. The centers of the circles are: (4, -2) and (-1, 5).

$$\text{The slope is } m = \frac{5-(-2)}{-1-4} = \frac{7}{-5} = -\frac{7}{5}. \text{ Use the}$$

slope and one point to find the equation of the line.

$$y-(-2) = -\frac{7}{5}(x-4)$$

$$y+2 = -\frac{7}{5}x + \frac{28}{5}$$

$$5y+10 = -7x+28$$

$$7x+5y = 18$$

52. Find the centers of the two circles:

$$x^2 + y^2 - 4x + 6y + 4 = 0$$

$$(x^2 - 4x + 4) + (y^2 + 6y + 9) = -4 + 4 + 9$$

$$(x-2)^2 + (y+3)^2 = 9$$

$$\text{Center: } (2, -3)$$

$$x^2 + y^2 + 6x + 4y + 9 = 0$$

$$(x^2 + 6x + 9) + (y^2 + 4y + 4) = -9 + 9 + 4$$

$$(x+3)^2 + (y+2)^2 = 4$$

$$\text{Center: } (-3, -2)$$

Find the slope of the line containing the centers:

$$m = \frac{-2-(-3)}{-3-2} = \frac{1}{-5}$$

Find the equation of the line containing the centers:

$$y+3 = -\frac{1}{5}(x-2)$$

$$5y+15 = -x+2$$

$$x+5y = -13$$

$$x+5y+13 = 0$$

Chapter 2: Graphs

53. Consider the following diagram:

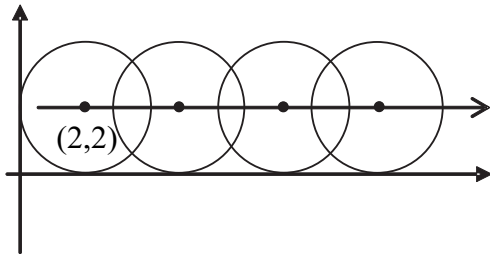

Therefore, the path of the center of the circle has the equation $y = 2$.

54. Consider the following diagram:

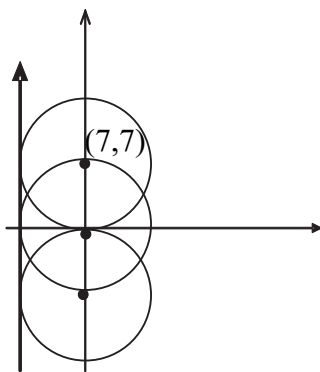

Therefore the path of the center of the circle has the equation $x = 7$.

55. Let the upper-right corner of the square be the point (x, y) . The circle and the square are both centered about the origin. Because of symmetry, we have that $x = y$ at the upper-right corner of the square. Therefore, we get

$$\begin{aligned} x^2 + y^2 &= 9 \\ x^2 + x^2 &= 9 \\ 2x^2 &= 9 \\ x^2 &= \frac{9}{2} \\ x &= \sqrt{\frac{9}{2}} = \frac{3\sqrt{2}}{2} \end{aligned}$$

The length of one side of the square is $2x$. Thus, the area is

$$A = s^2 = \left(2 \cdot \frac{3\sqrt{2}}{2}\right)^2 = (3\sqrt{2})^2 = 18 \text{ square units.}$$

56. The area of the shaded region is the area of the circle, less the area of the square. Let the upper-right corner of the square be the point (x, y) . The circle and the square are both centered about

the origin. Because of symmetry, we have that $x = y$ at the upper-right corner of the square.

Therefore, we get

$$\begin{aligned} x^2 + y^2 &= 36 \\ x^2 + x^2 &= 36 \\ 2x^2 &= 36 \\ x^2 &= 18 \\ x &= 3\sqrt{2} \end{aligned}$$

The length of one side of the square is $2x$. Thus, the area of the square is $(2 \cdot 3\sqrt{2})^2 = 72$ square units. From the equation of the circle, we have $r = 6$. The area of the circle is $\pi r^2 = \pi(6)^2 = 36\pi$ square units. Therefore, the area of the shaded region is $A = 36\pi - 72$ square units.

57. The diameter of the Ferris wheel was 250 feet, so the radius was 125 feet. The maximum height was 264 feet, so the center was at a height of $264 - 125 = 139$ feet above the ground. Since the center of the wheel is on the y -axis, it is the point $(0, 139)$. Thus, an equation for the wheel is:
- $$\begin{aligned} (x-0)^2 + (y-139)^2 &= 125^2 \\ x^2 + (y-139)^2 &= 15,625 \end{aligned}$$

58. The diameter of the wheel is 520 feet, so the radius is 260 feet. The maximum height is 550 feet, so the center of the wheel is at a height of $550 - 260 = 290$ feet above the ground. Since the center of the wheel is on the y -axis, it is the point $(0, 290)$. Thus, an equation for the wheel is:

$$\begin{aligned} (x-0)^2 + (y-290)^2 &= 260^2 \\ x^2 + (y-290)^2 &= 67,600 \end{aligned}$$

- 59.

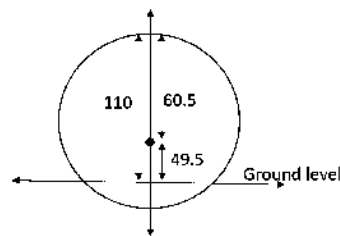

Refer to figure. Since the radius of the building is 60.5 m and the height of the building is 110 m,

then the center of the building is 49.5 m above the ground, so the y -coordinate of the center is 49.5. The equation of the circle is given by $x^2 + (y - 49.5)^2 = 60.5^2 = 3660.25$

60. Complete the square to find the equation of the circle representing the formula for the building.

$$x^2 + y^2 - 78y + 1521 = 1843 + 1521 = 3364$$

$$x^2 + (y - 39)^2 = 58^2$$

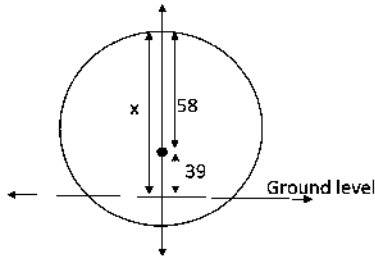

Refer to figure. The y coordinate of the center is 39. The radius is 58. Thus the height of the building is $58 + 39 = 97$ m.

61. Center at $(2, 3)$; tangent to the x -axis.

$$r = 3$$

$$\text{Equation: } (x - 2)^2 + (y - 3)^2 = 3^2$$

$$(x - 2)^2 + (y - 3)^2 = 9$$

62. Center at $(-3, 1)$; tangent to the y -axis.

$$r = 3$$

$$\text{Equation: } (x + 3)^2 + (y - 1)^2 = 3^2$$

$$(x + 3)^2 + (y - 1)^2 = 9$$

63. Center at $(-1, 3)$; tangent to the line $y = 2$.

This means that the circle contains the point $(-1, 2)$, so the radius is $r = 1$.

$$\text{Equation: } (x + 1)^2 + (y - 3)^2 = (1)^2$$

$$(x + 1)^2 + (y - 3)^2 = 1$$

64. Center at $(4, -2)$; tangent to the line $x = 1$.

This means that the circle contains the point $(1, -2)$, so the radius is $r = 3$.

$$\text{Equation: } (x - 4)^2 + (y + 2)^2 = (3)^2$$

$$(x - 4)^2 + (y + 2)^2 = 9$$

65. a. Substitute $y = mx + b$ into $x^2 + y^2 = r^2$:

$$x^2 + (mx + b)^2 = r^2$$

$$x^2 + m^2x^2 + 2bmx + b^2 = r^2$$

$$(1 + m^2)x^2 + 2bmx + b^2 - r^2 = 0$$

This equation has one solution if and only if the discriminant is zero.

$$(2bm)^2 - 4(1 + m^2)(b^2 - r^2) = 0$$

$$4b^2m^2 - 4b^2 + 4r^2 - 4b^2m^2 + 4m^2r^2 = 0$$

$$-4b^2 + 4r^2 + 4m^2r^2 = 0$$

$$-b^2 + r^2 + m^2r^2 = 0$$

$$r^2(1 + m^2) = b^2$$

- b. From part (a) we know

$(1 + m^2)x^2 + 2bmx + b^2 - r^2 = 0$. Using the quadratic formula, since the discriminant is zero, we get:

$$x = \frac{-2bm}{2(1 + m^2)} = \frac{-bm}{\left(\frac{b^2}{r^2}\right)} = \frac{-bmr^2}{b^2} = \frac{-mr^2}{b}$$

$$y = m\left(\frac{-mr^2}{b}\right) + b$$

$$= \frac{-m^2r^2}{b} + b = \frac{-m^2r^2 + b^2}{b} = \frac{r^2}{b}$$

The point of tangency is $\left(\frac{-mr^2}{b}, \frac{r^2}{b}\right)$.

- c. The slope of the tangent line is m .

The slope of the line joining the point of tangency and the center $(0, 0)$ is:

$$\frac{\left(\frac{r^2}{b} - 0\right)}{\left(\frac{-mr^2}{b} - 0\right)} = \frac{r^2}{b} \cdot \frac{b}{-mr^2} = -\frac{1}{m}$$

The two lines are perpendicular.

66. Let (h, k) be the center of the circle.

$$x - 2y + 4 = 0$$

$$2y = x + 4$$

$$y = \frac{1}{2}x + 2$$

The slope of the tangent line is $\frac{1}{2}$. The slope

from (h, k) to $(0, 2)$ is -2 .

Chapter 2: Graphs

$$\frac{2-k}{0-h} = -2$$

$$2-k = 2h$$

The other tangent line is $y = 2x - 7$, and it has slope 2.

The slope from (h, k) to $(3, -1)$ is $-\frac{1}{2}$.

$$\frac{-1-k}{3-h} = -\frac{1}{2}$$

$$2+2k = 3-h$$

$$2k = 1-h$$

$$h = 1-2k$$

Solve the two equations in h and k :

$$2-k = 2(1-2k)$$

$$2-k = 2-4k$$

$$3k = 0$$

$$k = 0$$

$$h = 1-2(0) = 1$$

The center of the circle is $(1, 0)$.

67. The slope of the line containing the center $(0,0)$ and $(1, 2\sqrt{2})$ is

$$\frac{2\sqrt{2}-0}{1-0} = 2\sqrt{2}. \text{ Then the slope of the tangent}$$

$$\text{line is } \frac{-1}{2\sqrt{2}} = -\frac{\sqrt{2}}{4}.$$

So the equation of the tangent line is:

$$y - 2\sqrt{2} = -\frac{\sqrt{2}}{4}(x-1)$$

$$y - 2\sqrt{2} = -\frac{\sqrt{2}}{4}x + \frac{\sqrt{2}}{4}$$

$$4y - 8\sqrt{2} = -\sqrt{2}x + \sqrt{2}$$

$$\sqrt{2}x + 4y = 9\sqrt{2}$$

68. $x^2 + y^2 - 4x + 6y + 4 = 0$

$$(x^2 - 4x + 4) + (y^2 + 6y + 9) = -4 + 4 + 9$$

$$(x-2)^2 + (y+3)^2 = 9$$

Center: $(2, -3)$

The slope of the line containing the center and

$$(3, 2\sqrt{2}-3) \text{ is } \frac{2\sqrt{2}-3-(-3)}{3-2} = \frac{2\sqrt{2}}{1} = 2\sqrt{2}$$

Then the slope of the tangent line is: $\frac{-1}{2\sqrt{2}} = -\frac{\sqrt{2}}{4}$

So, the equation of the tangent line is

$$y - (2\sqrt{2}-3) = -\frac{\sqrt{2}}{4}(x-3)$$

$$y - 2\sqrt{2} + 3 = -\frac{\sqrt{2}}{4}x + \frac{3\sqrt{2}}{4}$$

$$4y - 8\sqrt{2} + 12 = -\sqrt{2}x + 3\sqrt{2}$$

$$\sqrt{2}x + 4y = 11\sqrt{2} - 12$$

69. The center of the circle is $\left(\frac{x_1+x_2}{2}, \frac{y_1+y_2}{2}\right)$ and the radius is $\frac{1}{2}\sqrt{(x_1-x_2)^2 + (y_1-y_2)^2}$. Then the equation of

the circle is $\left(x - \frac{x_1+x_2}{2}\right)^2 + \left(y - \frac{y_1+y_2}{2}\right)^2 = \frac{1}{4}[(x_1-x_2)^2 + (y_1-y_2)^2]$. Expanding, gives

$$x^2 - x(x_1+x_2) + \frac{(x_1+x_2)^2}{4} + y^2 - y(y_1+y_2) + \frac{(y_1+y_2)^2}{4} = \frac{1}{4}[x_1^2 - 2x_1x_2 + x_2^2 + y_1^2 - 2y_1y_2 + y_2^2]$$

$$4x^2 - 4x_1x - 4x_2x + x_1^2 + 2x_1x_2 + x_2^2 + 4y^2 - 4y_1y - 4y_2y + y_1^2 + 2y_1y_2 + y_2^2 = x_1^2 - 2x_1x_2 + x_2^2 + y_1^2 - 2y_1y_2 + y_2^2$$

$$4x^2 - 4x_1x - 4x_2x + 4x_1x_2 + 4y^2 - 4y_1y - 4y_2y + 4y_1y_2 = 0$$

$$x^2 - x_1x - x_2x + x_1x_2 + y^2 - y_1y - y_2y + y_1y_2 = 0$$

$$x(x-x_1) - x_2(x+x_1) + y(y-y_1) - y_2(y+y_1) = 0$$

$$(x-x_1)(x-x_2) + (y-y_1)(y-y_2) = 0$$

70. Complete the square to get $\left(x + \frac{d}{2}\right)^2 + \left(y + \frac{e}{2}\right)^2 = \frac{d^2 + e^2 - 4f}{4}$. The slope of the line between the center

$\left(-\frac{d}{2}, -\frac{e}{2}\right)$ and the point of tangency (x_0, y_0) is $m = \frac{y_0 + \frac{e}{2}}{x_0 + \frac{d}{2}}$. So the slope of the tangent line is $m_{\text{tan}} = -\frac{x_0 + \frac{d}{2}}{y_0 + \frac{e}{2}}$.

Therefore, the equation of the tangent line is $y - y_0 = -\frac{x_0 + \frac{d}{2}}{y_0 + \frac{e}{2}}(x - x_0)$ which is equivalent to

$$\begin{aligned}(x - x_0)\left(x_0 + \frac{d}{2}\right) + (y - y_0)\left(y_0 + \frac{e}{2}\right) &= 0 \\ x_0x + \frac{d}{2}x - x_0^2 - \frac{d}{2}x_0 + y_0y + \frac{e}{2}y - y_0^2 - \frac{e}{2}y_0 &= 0 \\ x_0x + y_0y + \frac{d}{2}x + \frac{e}{2}y - \left(x_0^2 + y_0^2 + \frac{d}{2}x_0 + \frac{e}{2}y_0\right) &= 0\end{aligned}$$

Because (x_0, y_0) is on the circle, $x_0^2 + y_0^2 + dx_0 + ey_0 + f = 0$, and

$$x_0^2 + y_0^2 + \frac{d}{2}x_0 + \frac{e}{2}y_0 = -\frac{d}{2}x_0 - \frac{e}{2}y_0 - f \quad \text{Substituting this result gives}$$

$$\begin{aligned}x_0^2 + y_0^2 + \frac{d}{2}x_0 + \frac{e}{2}y_0 - \left(-\frac{d}{2}x_0 - \frac{e}{2}y_0 - f\right) &= 0 \\ x_0^2 + y_0^2 + \frac{d}{2}x_0 + \frac{e}{2}y_0 + \frac{d}{2}x_0 + \frac{e}{2}y_0 + f &= 0 \\ x_0^2 + y_0^2 + d\left(\frac{x_0}{2}\right) + e\left(\frac{y_0}{2}\right) + f &= 0\end{aligned}$$

71. (b), (c), (e) and (g)

We need $h, k > 0$ and $(0, 0)$ on the graph.

72. (b), (e) and (g)

We need $h < 0$, $k = 0$, and $|h| > r$.

73. Answers will vary.

74. The student has the correct radius, but the signs of the coordinates of the center are incorrect. The student needs to write the equation in the standard form $(x - h)^2 + (y - k)^2 = r^2$.

$$(x + 3)^2 + (y - 2)^2 = 16$$

$$(x - (-3))^2 + (y - 2)^2 = 4^2$$

Thus, $(h, k) = (-3, 2)$ and $r = 4$.

$$75. A = \pi r^2$$

$$= \pi(13)^2$$

$$= 169\pi \text{ cm}^2$$

$$C = 2\pi r$$

$$= 2\pi(13)$$

$$= 26\pi \text{ cm}$$

$$\begin{aligned}76. (3x - 2)(x^2 - 2x + 3) &= 3x^3 - 6x^2 + 9x - 2x^2 + 4x - 6 \\ &= 3x^3 - 8x^2 + 13x - 6\end{aligned}$$

$$77. \sqrt{2x^2 + 3x - 1} = x + 1$$

$$2x^2 + 3x - 1 = (x + 1)^2$$

$$2x^2 + 3x - 1 = x^2 + 2x + 1$$

$$x^2 + x - 2 = 0$$

$$(x + 2)(x - 1) = 0$$

$$x = -2 \text{ or } x = 1$$

Chapter 2: Graphs

We need to check each possible solution:

Check $x = -2$

$$\sqrt{2(-2)^2 + 3(-2) - 1} = (-2) + 1$$

$$\sqrt{2(4) - 6 - 1} = -1$$

no

Check $x = 1$

$$\sqrt{2(1)^2 + 3(1) - 1} = (1) + 1$$

$$\sqrt{2 + 3 - 1} = 2$$

$$\sqrt{4} = 2$$

yes

The solution is $\{1\}$

78. Let t represent the time it takes to do the job together.

	Time to do job	Part of job done in one minute
Aaron	22	$\frac{1}{22}$
Elizabeth	28	$\frac{1}{28}$
Together	t	$\frac{1}{t}$

$$\frac{1}{22} + \frac{1}{28} = \frac{1}{t}$$

$$14t + 11t = 308$$

$$25t = 308$$

$$t = 12.32$$

Working together, the job can be done in 12.32 minutes.

79. $9.57 \times 10^{-5} = 0.0000957$

80.

$$\begin{array}{r}
 4x^3 - 5x^2 + 7x - 2 \\
 2x^2 - 3 \overline{) 8x^5 - 10x^4 + 2x^3 + 11x^2 - 16x + 7} \\
 \underline{8x^5} \qquad \quad \underline{-12x^3} \\
 -10x^4 + 14x^3 + 11x^2 \\
 \underline{-10x^4} \qquad \quad \underline{+15x^2} \\
 14x^3 - 4x^2 - 16x \\
 \underline{14x^3} \qquad \quad \underline{-21x} \\
 -4x^2 + 5x + 7 \\
 \underline{-4x^2} \qquad \quad \underline{+6} \\
 5x + 1
 \end{array}$$

The quotient is $4x^3 - 5x^2 + 7x - 2$; the remainder is $5x + 1$.

81. $12x^5 - 15x^4 + 84x^3 - 105x^2 =$
 $3x^2(4x^3 - 5x^2 + 28x - 35) =$
 $3x^2[x^2(4x - 5) + 7(4x - 5)] =$
 $3x^2(4x - 5)(x^2 + 7)$

82. $\sqrt[4]{405x^{11}y^{20}} = \sqrt[4]{3^4 \cdot 5 \cdot x^8 \cdot x^3 y^{20}}$
 $= 3x^2y^5\sqrt[4]{5x^3}$

83. Since the area of the square is 64 square meters then each side must be 8 square meters. Thus the diagonal of the square is $\sqrt{64^2 + 64^2} = \sqrt{128} = 8\sqrt{2}$ square meters. Thus the diameter of the circle is also $8\sqrt{2}$ square meters and the radius is $4\sqrt{2}$ square meters. The circumference of the circle is:

$$C = 2\pi r = 2\pi(4\sqrt{2}) = 8\pi\sqrt{2} \text{ m. The area of the circle is:}$$

$$A = \pi r^2 = \pi(4\sqrt{2})^2 = 32\pi \text{ m}^2$$

84. Let X be the amount of pure antifreeze to be added.

2 L	X L	2 + X L
0.40	1.0	0.75

$$2(0.40) + 1(X) = (2 + X)0.75$$

$$2(0.40) + 1(X) = (2 + X)0.75$$

$$0.8 + X = 1.5 + 0.75X$$

$$0.25X = 0.7$$

$$X = 2.8$$

You need to add 2.8 liters of pure antifreeze.

Section 2.5

1. $y = kx$

2. False. If y varies directly with x , then $y = kx$, where k is a constant.

3. d

4. c

5. $y = kx$

$$2 = 10k$$

$$k = \frac{2}{10} = \frac{1}{5}$$

$$y = \frac{1}{5}x$$

6. $v = kt$

$$16 = 2k$$

$$8 = k$$

$$v = 8t$$

7. $V = kx^3$

$$36\pi = k(3)^3$$

$$36\pi = 27k$$

$$k = \frac{36\pi}{27} = \frac{4}{3}\pi$$

$$V = \frac{4}{3}\pi x^3$$

8. $A = kx^2$

$$4\pi = k(2)^2$$

$$4\pi = 4k$$

$$\pi = k$$

$$A = \pi x^2$$

9. $y = \frac{k}{\sqrt{x}}$

$$4 = \frac{k}{\sqrt{9}}$$

$$4 = \frac{k}{3}$$

$$k = 12$$

$$y = \frac{12}{\sqrt{x}}$$

10. $F = \frac{k}{d^2}$

$$10 = \frac{k}{5^2}$$

$$10 = \frac{k}{25}$$

$$k = 250$$

$$F = \frac{250}{d^2}$$

11. $z = k(x^2 + y^2)$

$$26 = k(5^2 + 12^2)$$

$$26 = k(169)$$

$$k = \frac{26}{169} = \frac{2}{13}$$

$$z = \frac{2}{13}(x^2 + y^2)$$

12. $T = k(\sqrt[3]{x})(d^2)$

$$18 = k(\sqrt[3]{8})(3^2)$$

$$18 = k(18)$$

$$1 = k$$

$$T = (\sqrt[3]{x})(d^2) = d^2\sqrt[3]{x}$$

Chapter 2: Graphs

$$13. \quad M = \frac{kd^2}{\sqrt{x}}$$

$$24 = \frac{k(4^2)}{\sqrt{9}}$$

$$24 = \frac{16k}{3}$$

$$k = 24 \left(\frac{3}{16} \right) = \frac{9}{2}$$

$$M = \frac{9d^2}{2\sqrt{x}}$$

$$14. \quad z = k(x^3 + y^2)$$

$$1 = k(2^3 + 3^2)$$

$$1 = k(17)$$

$$k = \frac{1}{17}$$

$$z = \frac{1}{17}(x^3 + y^2)$$

$$15. \quad T^2 = \frac{ka^3}{d^2}$$

$$2^2 = \frac{k(2^3)}{4^2}$$

$$4 = \frac{k(8)}{16}$$

$$4 = \frac{k}{2}$$

$$k = 8$$

$$T^2 = \frac{8a^3}{d^2}$$

$$16. \quad z^3 = k(x^2 + y^2)$$

$$2^3 = k(9^2 + 4^2)$$

$$8 = k(97)$$

$$k = \frac{8}{97}$$

$$z^3 = \frac{8}{97}(x^2 + y^2)$$

$$17. \quad V = \frac{4\pi}{3}r^3$$

$$18. \quad c^2 = a^2 + b^2$$

$$19. \quad p = 2(l + w)$$

$$20. \quad A = \frac{1}{2}bh$$

$$21. \quad F = (6.67 \times 10^{-11}) \left(\frac{mM}{d^2} \right)$$

$$22. \quad T = \frac{2\pi}{\sqrt{32}}\sqrt{l}$$

$$23. \quad p = kB$$

$$6.49 = k(1000)$$

$$0.00649 = k$$

Therefore we have the linear equation

$$p = 0.00649B.$$

If $B = 145000$, then

$$p = 0.00649(145000) = \$941.05.$$

$$24. \quad p = kB$$

$$8.99 = k(1000)$$

$$0.00899 = k$$

Therefore we have the linear equation

$$p = 0.00899B.$$

If $B = 175000$, then

$$p = 0.00899(175000) = \$1573.25.$$

$$25. \quad s = kt^2$$

$$16 = k(1)^2$$

$$k = 16$$

Therefore, we have equation $s = 16t^2$.

If $t = 3$ seconds, then $s = 16(3)^2 = 144$ feet.

If $s = 64$ feet, then

$$64 = 16t^2$$

$$t^2 = 4$$

$$t = \pm 2$$

Time must be positive, so we disregard $t = -2$.

It takes 2 seconds to fall 64 feet.

26. $v = kt$

$$64 = k(2)$$

$$k = 32$$

Therefore, we have the linear equation $v = 32t$.If $t = 3$ seconds, then $v = 32(3) = 96$ ft/sec.

27. $E = kW$

$$3 = k(20)$$

$$k = \frac{3}{20}$$

Therefore, we have the linear equation $E = \frac{3}{20}W$.If $W = 15$, then $E = \frac{3}{20}(15) = 2.25$.

28. $R = \frac{k}{l}$

$$256 = \frac{k}{48}$$

$$k = 12,288$$

Therefore, we have the equation $R = \frac{12,288}{l}$.If $R = 576$, then

$$576 = \frac{12,288}{l}$$

$$576l = 12,288$$

$$l = \frac{12,288}{576} = \frac{64}{3} \text{ inches}$$

29. $R = kg$

$$34.08 = k(12)$$

$$2.84 = k$$

Therefore, we have the linear equation $R = 2.84g$.If $g = 10.5$, then $R = (2.84)(10.5) = \$29.82$.

30. $C = kA$

$$23.75 = k(5)$$

$$4.75 = k$$

Therefore, we have the linear equation $C = 4.75A$.If $A = 3.5$, then $C = (4.75)(3.5) = \$16.63$.

31. $D = \frac{k}{p}$

a. $D = 156$, $p = 2.75$;

$$156 = \frac{k}{2.75}$$

$$k = 429$$

So, $D = \frac{429}{p}$.

b. $D = \frac{429}{3} = 143$ bags of candy

32. $t = \frac{k}{s}$

a. $t = 40$, $s = 30$;

$$40 = \frac{k}{30}$$

$$k = 1200$$

So, we have the equation $t = \frac{1200}{s}$.

b. $t = \frac{1200}{40} = 30$ minutes

33. $V = \frac{k}{P}$

$V = 600$, $P = 150$;

$$600 = \frac{k}{150}$$

$$k = 90,000$$

So, we have the equation $V = \frac{90,000}{P}$

If $P = 200$, then $V = \frac{90,000}{200} = 450 \text{ cm}^3$.

34. $i = \frac{k}{R}$

If $i = 30$, $R = 8$, then $30 = \frac{k}{8}$ and $k = 240$.

So, we have the equation $i = \frac{240}{R}$.

If $R = 10$, then $i = \frac{240}{10} = 24$ amperes.

35. $W = \frac{k}{d^2}$

If $W = 125$, $d = 3960$ then

Chapter 2: Graphs

$$125 = \frac{k}{3960^2} \text{ and } k = 1,960,200,000$$

So, we have the equation $W = \frac{1,960,200,000}{d}$.

At the top of Mt. McKinley, we have $d = 3960 + 3.8 = 3963.8$, so

$$W = \frac{1,960,200,000}{(3963.8)^2} \approx 124.76 \text{ pounds.}$$

36. $W = \frac{k}{d^2}$

$$55 = \frac{k}{3960^2}$$

$$k = 862,488,000$$

So, we have the equation $W = \frac{862,488,000}{d^2}$.

If $d=3965$, then

$$W = \frac{862,488,000}{3965^2} \approx 54.86 \text{ pounds.}$$

37. $V = \pi r^2 h$

38. $V = \frac{\pi}{3} r^2 h$

39. $I = \frac{k}{d^2}$

If $I = 0.075$, $d = 2$, then

$$0.075 = \frac{k}{2^2} \text{ and } k = 0.3.$$

So, we have the equation $I = \frac{0.3}{d^2}$.

If $d = 5$, then $I = \frac{0.3}{5^2} = 0.012$ foot-candles.

40. $F = kAv^2$

$$11 = k(20)(22)^2$$

$$11 = 9860k$$

$$k = \frac{11}{9860} = \frac{1}{880}$$

So, we have the equation $F = \frac{1}{880} Av^2$.

If $A = 47.125$ and $v = 36.5$, then

$$F = \frac{1}{880} (47.125)(36.5)^2 \approx 71.34 \text{ pounds.}$$

41. $h = ksd^3$

$$36 = k(75)(2)^3$$

$$36 = 600k$$

$$0.06 = k$$

So, we have the equation $h = 0.06sd^3$.

If $h = 45$ and $s = 125$, then

$$45 = (0.06)(125)d^3$$

$$45 = 7.5d^3$$

$$6 = d^3$$

$$d = \sqrt[3]{6} \approx 1.82 \text{ inches}$$

42. $V = \frac{kT}{P}$

$$100 = \frac{k(300)}{15}$$

$$100 = 20k$$

$$5 = k$$

So, we have the equation $V = \frac{5T}{P}$.

If $V = 80$ and $T = 310$, then

$$80 = \frac{5(310)}{P}$$

$$80P = 1550$$

$$P = \frac{1550}{80} = 19.375 \text{ atmospheres}$$

43. $R = \frac{kl}{d^2}$

$$1.24 = \frac{k(432)}{(4)^2}$$

$$1.24 = 27k$$

$$k = \frac{1.24}{27}$$

So, we have the equation $R = \frac{1.24l}{27d^2}$.

If $R = 1.44$ and $d = 3$, then

$$1.44 = \frac{1.24l}{27(3)^2}$$

$$1.44 = \frac{1.24l}{243}$$

$$349.92 = 1.24l$$

$$l = \frac{349.92}{1.24} \approx 282.2 \text{ feet}$$

$$44. \quad K = kmv^2$$

$$1250 = k(25)(10)^2$$

$$1250 = 2500k$$

$$k = 0.5$$

So, we have the equation $K = 0.5mv^2$.

If $m = 25$ and $v = 15$, then

$$K = 0.5(25)(15)^2 = 2812.5 \text{ Joules}$$

$$45. \quad S = \frac{kpd}{t}$$

$$100 = \frac{k(25)(5)}{0.75}$$

$$75 = 125k$$

$$0.6 = k$$

So, we have the equation $S = \frac{0.6pd}{t}$.

If $p = 40$, $d = 8$, and $t = 0.50$, then

$$S = \frac{0.6(40)(8)}{0.50} = 384 \text{ psi.}$$

$$46. \quad S = \frac{kwt^2}{l}$$

$$750 = \frac{k(4)(2)^2}{8}$$

$$750 = 2k$$

$$375 = k$$

So, we have the equation $S = \frac{375wt^2}{l}$.

If $l = 10$, $w = 6$, and $t = 2$, then

$$S = \frac{375(6)(2)^2}{10} = 900 \text{ pounds.}$$

47 – 50. Answers will vary.

$$\begin{aligned} 51. \quad & 3x^3 + 25x^2 - 12x - 100 \\ &= (3x^3 + 25x^2) - (12x + 100) \\ &= x^2(3x + 25) - 4(3x + 25) \\ &= (x^2 - 4)(3x + 25) \\ &= (x - 2)(x + 2)(3x + 25) \end{aligned}$$

52.

$$\begin{aligned} \frac{5}{x+3} + \frac{x-2}{x^2+7x+12} &= \frac{5}{x+3} + \frac{x-2}{(x+3)(x+4)} \\ &= \frac{5(x+4)}{(x+3)(x+4)} + \frac{x-2}{(x+3)(x+4)} \\ &= \frac{5(x+4) + (x-2)}{(x+3)(x+4)} \\ &= \frac{5x+20+x-2}{(x+3)(x+4)} \\ &= \frac{6x+18}{(x+3)(x+4)} \\ &= \frac{6(x+3)}{(x+3)(x+4)} = \frac{6}{x+4} \end{aligned}$$

$$53. \quad \left(\frac{4}{25}\right)^{\frac{3}{2}} = \left(\left(\frac{4}{25}\right)^{\frac{1}{2}}\right)^3$$

$$\left(\frac{2}{5}\right)^3 = \frac{8}{125}$$

54. The term needed to rationalize the denominator is $\sqrt{7} + 2$.

$$\begin{aligned} 55. \quad \frac{(5)^2 - (2)^2}{(3)(5) - 2(2)(5-3)} &= \frac{25-4}{15-(4)(2)} \\ &= \frac{21}{7} = 3 \end{aligned}$$

$$56. \quad 6x - 2(x - 4) = 24$$

$$6x - 2x + 8 = 24$$

$$4x = 16$$

$$x = 4$$

The solution set is $\{4\}$.

$$57. \quad \frac{6}{x} - \frac{1}{10} = \frac{1}{5}$$

$$10x\left(\frac{6}{x} - \frac{1}{10}\right) = 10x\left(\frac{1}{5}\right)$$

$$60 - x = 2x$$

$$-3x = -60$$

$$x = 20$$

The solution set is $\{20\}$

Chapter 2: Graphs

$$\begin{aligned}
 58. \quad & 10x^2 = 117 - 19x \\
 & 10x^2 + 19x - 117 = 0 \\
 & (5x - 13)(2x + 9) = 0 \\
 & \quad 5x - 13 = 0 \quad \text{or} \quad 2x + 9 = 0 \\
 & \quad 5x = 13 \quad \quad 2x = -9 \\
 & \quad x = \frac{13}{5} \quad \quad x = -\frac{9}{2}
 \end{aligned}$$

The solution set is $\left\{-\frac{9}{2}, \frac{13}{5}\right\}$.

$$\begin{aligned}
 59. \quad & 7 - 3|4x - 7| = 4 \\
 & -3|4x - 7| = -3 \\
 & |4x - 7| = 1 \\
 & \quad 4x - 7 = -1 \quad \text{or} \quad 4x - 7 = 1 \\
 & \quad 4x = 6 \quad \quad 4x = 8 \\
 & \quad x = \frac{6}{4} = \frac{3}{2} \quad \quad x = 2
 \end{aligned}$$

The solution set is $\left\{\frac{3}{2}, 2\right\}$.

$$\begin{aligned}
 60. \quad & 5(x + 2) - 9x > x - 3(2x + 1) + 7 \\
 & 5x + 10 - 9x > x - 6x - 3 + 7 \\
 & 10 - 4x > -5x + 4 \\
 & \quad x > -6
 \end{aligned}$$

The solution is $\{x \mid x > -6\}$.

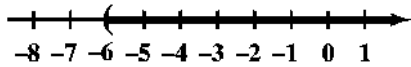

Chapter 2 Review Exercises

1. $P_1 = (0, 0)$ and $P_2 = (4, 2)$

$$\begin{aligned}
 \text{a.} \quad d(P_1, P_2) &= \sqrt{(4-0)^2 + (2-0)^2} \\
 &= \sqrt{16+4} = \sqrt{20} = 2\sqrt{5}
 \end{aligned}$$

b. The coordinates of the midpoint are:

$$\begin{aligned}
 (x, y) &= \left(\frac{x_1 + x_2}{2}, \frac{y_1 + y_2}{2}\right) \\
 &= \left(\frac{0+4}{2}, \frac{0+2}{2}\right) = \left(\frac{4}{2}, \frac{2}{2}\right) = (2, 1)
 \end{aligned}$$

c. slope = $\frac{\Delta y}{\Delta x} = \frac{2-0}{4-0} = \frac{2}{4} = \frac{1}{2}$

d. For each run of 2, there is a rise of 1.

2. $P_1 = (1, -1)$ and $P_2 = (-2, 3)$

$$\begin{aligned}
 \text{a.} \quad d(P_1, P_2) &= \sqrt{(-2-1)^2 + (3-(-1))^2} \\
 &= \sqrt{9+16} = \sqrt{25} = 5
 \end{aligned}$$

b. The coordinates of the midpoint are:

$$\begin{aligned}
 (x, y) &= \left(\frac{x_1 + x_2}{2}, \frac{y_1 + y_2}{2}\right) \\
 &= \left(\frac{1+(-2)}{2}, \frac{-1+3}{2}\right) \\
 &= \left(\frac{-1}{2}, \frac{2}{2}\right) = \left(-\frac{1}{2}, 1\right)
 \end{aligned}$$

c. slope = $\frac{\Delta y}{\Delta x} = \frac{3-(-1)}{-2-1} = \frac{4}{-3} = -\frac{4}{3}$

d. For each run of 3, there is a rise of -4 .

3. $P_1 = (4, -4)$ and $P_2 = (4, 8)$

$$\begin{aligned}
 \text{a.} \quad d(P_1, P_2) &= \sqrt{(4-4)^2 + (8-(-4))^2} \\
 &= \sqrt{0+144} = \sqrt{144} = 12
 \end{aligned}$$

b. The coordinates of the midpoint are:

$$\begin{aligned}
 (x, y) &= \left(\frac{x_1 + x_2}{2}, \frac{y_1 + y_2}{2}\right) \\
 &= \left(\frac{4+4}{2}, \frac{-4+8}{2}\right) = \left(\frac{8}{2}, \frac{4}{2}\right) = (4, 2)
 \end{aligned}$$

c. slope = $\frac{\Delta y}{\Delta x} = \frac{8-(-4)}{4-4} = \frac{12}{0}$, undefined

d. An undefined slope means the points lie on a vertical line. There is no change in x .

4. $2x = 3y^2$

x-intercepts: y-intercepts:

$2x = 3(0)^2$ $2(0) = 3y^2$

$2x = 0$ $0 = y^2$

$x = 0$ $y = 0$

The only intercept is (0, 0).

Test x-axis symmetry: Let $y = -y$

$2x = 3(-y)^2$

$2x = 3y^2$ same

Test y-axis symmetry: Let $x = -x$

$2(-x) = 3y^2$

$-2x = 3y^2$ different

Test origin symmetry: Let $x = -x$ and $y = -y$.

$2(-x) = 3(-y)^2$

$-2x = 3y^2$ different

Therefore, the graph will have x-axis symmetry.

5. $x^2 + 4y^2 = 16$

x-intercepts: y-intercepts:

$x^2 + 4(0)^2 = 16$ $(0)^2 + 4y^2 = 16$

$x^2 = 16$ $4y^2 = 16$

$x = \pm 4$ $y^2 = 4$

$y = \pm 2$

The intercepts are (-4, 0), (4, 0), (0, -2), and (0, 2).

Test x-axis symmetry: Let $y = -y$

$x^2 + 4(-y)^2 = 16$

$x^2 + 4y^2 = 16$ same

Test y-axis symmetry: Let $x = -x$

$(-x)^2 + 4y^2 = 16$

$x^2 + 4y^2 = 16$ same

Test origin symmetry: Let $x = -x$ and $y = -y$.

$(-x)^2 + 4(-y)^2 = 16$

$x^2 + 4y^2 = 16$ same

Therefore, the graph will have x-axis, y-axis, and origin symmetry.

6. $y = x^4 + 2x^2 + 1$

x-intercepts: y-intercepts:

$0 = x^4 + 2x^2 + 1$ $y = (0)^4 + 2(0)^2 + 1$

$0 = (x^2 + 1)(x^2 + 1)$ = 1

$x^2 + 1 = 0$

$x^2 = -1$

no real solutions

The only intercept is (0, 1).

Test x-axis symmetry: Let $y = -y$

$-y = x^4 + 2x^2 + 1$

$y = -x^4 - 2x^2 - 1$ different

Test y-axis symmetry: Let $x = -x$

$y = (-x)^4 + 2(-x)^2 + 1$

$y = x^4 + 2x^2 + 1$ same

Test origin symmetry: Let $x = -x$ and $y = -y$.

$-y = (-x)^4 + 2(-x)^2 + 1$

$-y = x^4 + 2x^2 + 1$

$y = -x^4 - 2x^2 - 1$ different

Therefore, the graph will have y-axis symmetry.

7. $y = x^3 - x$

x-intercepts: y-intercepts:

$0 = x^3 - x$ $y = (0)^3 - 0$

$0 = x(x^2 - 1)$ = 0

$0 = x(x+1)(x-1)$

$x = 0, x = -1, x = 1$

The intercepts are (-1, 0), (0, 0), and (1, 0).

Test x-axis symmetry: Let $y = -y$

$-y = x^3 - x$

$y = -x^3 + x$ different

Test y-axis symmetry: Let $x = -x$

$y = (-x)^3 - (-x)$

$y = -x^3 + x$ different

Test origin symmetry: Let $x = -x$ and $y = -y$.

$-y = (-x)^3 - (-x)$

$-y = -x^3 + x$

$y = x^3 - x$ same

Therefore, the graph will have origin symmetry.

Chapter 2: Graphs

8. $x^2 + x + y^2 + 2y = 0$

x -intercepts: $x^2 + x + (0)^2 + 2(0) = 0$
 $x^2 + x = 0$
 $x(x+1) = 0$
 $x = 0, x = -1$

y -intercepts: $(0)^2 + 0 + y^2 + 2y = 0$
 $y^2 + 2y = 0$
 $y(y+2) = 0$
 $y = 0, y = -2$

The intercepts are $(-1, 0)$, $(0, 0)$, and $(0, -2)$.

Test x -axis symmetry: Let $y = -y$

$x^2 + x + (-y)^2 + 2(-y) = 0$
 $x^2 + x + y^2 - 2y = 0$ different

Test y -axis symmetry: Let $x = -x$

$(-x)^2 + (-x) + y^2 + 2y = 0$
 $x^2 - x + y^2 + 2y = 0$ different

Test origin symmetry: Let $x = -x$ and $y = -y$.

$(-x)^2 + (-x) + (-y)^2 + 2(-y) = 0$
 $x^2 - x + y^2 - 2y = 0$ different

The graph has none of the indicated symmetries.

9. $(x-h)^2 + (y-k)^2 = r^2$

$(x - (-2))^2 + (y - 3)^2 = 4^2$
 $(x + 2)^2 + (y - 3)^2 = 16$

10. $(x-h)^2 + (y-k)^2 = r^2$

$(x - (-1))^2 + (y - (-2))^2 = 1^2$
 $(x + 1)^2 + (y + 2)^2 = 1$

11. $x^2 + (y-1)^2 = 4$

$x^2 + (y-1)^2 = 2^2$

Center: $(0, 1)$; Radius = 2

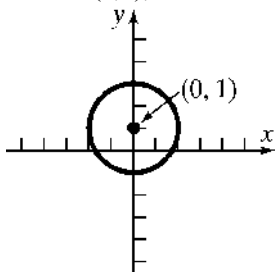

x -intercepts: $x^2 + (0-1)^2 = 4$

$x^2 + 1 = 4$
 $x^2 = 3$
 $x = \pm\sqrt{3}$

y -intercepts: $0^2 + (y-1)^2 = 4$

$(y-1)^2 = 4$
 $y-1 = \pm 2$
 $y = 1 \pm 2$
 $y = 3$ or $y = -1$

The intercepts are $(-\sqrt{3}, 0)$, $(\sqrt{3}, 0)$, $(0, -1)$, and $(0, 3)$.

12. $x^2 + y^2 - 2x + 4y - 4 = 0$

$x^2 - 2x + y^2 + 4y = 4$

$(x^2 - 2x + 1) + (y^2 + 4y + 4) = 4 + 1 + 4$

$(x-1)^2 + (y+2)^2 = 3^2$

Center: $(1, -2)$ Radius = 3

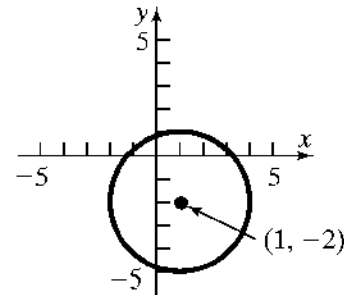

x -intercepts: $(x-1)^2 + (0+2)^2 = 3^2$

$(x-1)^2 + 4 = 9$
 $(x-1)^2 = 5$
 $x-1 = \pm\sqrt{5}$
 $x = 1 \pm \sqrt{5}$

y -intercepts: $(0-1)^2 + (y+2)^2 = 3^2$

$1 + (y+2)^2 = 9$
 $(y+2)^2 = 8$
 $y+2 = \pm\sqrt{8}$
 $y+2 = \pm 2\sqrt{2}$
 $y = -2 \pm 2\sqrt{2}$

The intercepts are $(1-\sqrt{5}, 0)$, $(1+\sqrt{5}, 0)$, $(0, -2-2\sqrt{2})$, and $(0, -2+2\sqrt{2})$.

$$\begin{aligned}
 13. \quad & 3x^2 + 3y^2 - 6x + 12y = 0 \\
 & x^2 + y^2 - 2x + 4y = 0 \\
 & x^2 - 2x + y^2 + 4y = 0 \\
 & (x^2 - 2x + 1) + (y^2 + 4y + 4) = 1 + 4 \\
 & (x-1)^2 + (y+2)^2 = (\sqrt{5})^2
 \end{aligned}$$

Center: $(1, -2)$ Radius = $\sqrt{5}$

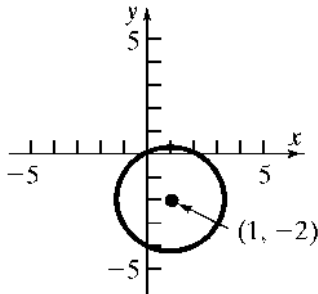

$$\begin{aligned}
 \text{x-intercepts: } & (x-1)^2 + (0+2)^2 = (\sqrt{5})^2 \\
 & (x-1)^2 + 4 = 5 \\
 & (x-1)^2 = 1 \\
 & x-1 = \pm 1 \\
 & x = 1 \pm 1 \\
 & x = 2 \quad \text{or} \quad x = 0 \\
 \text{y-intercepts: } & (0-1)^2 + (y+2)^2 = (\sqrt{5})^2 \\
 & 1 + (y+2)^2 = 5 \\
 & (y+2)^2 = 4 \\
 & y+2 = \pm 2 \\
 & y = -2 \pm 2 \\
 & y = 0 \quad \text{or} \quad y = -4
 \end{aligned}$$

The intercepts are $(0, 0)$, $(2, 0)$, and $(0, -4)$.

$$\begin{aligned}
 14. \quad & \text{Slope} = -2; \text{ containing } (3, -1) \\
 & y - y_1 = m(x - x_1) \\
 & y - (-1) = -2(x - 3) \\
 & y + 1 = -2x + 6 \\
 & y = -2x + 5 \quad \text{or} \quad 2x + y = 5
 \end{aligned}$$

15. vertical; containing $(-3, 4)$
 Vertical lines have equations of the form $x = a$, where a is the x -intercept. Now, a vertical line containing the point $(-3, 4)$ must have an x -intercept of -3 , so the equation of the line is $x = -3$. The equation does not have a slope-intercept form.

$$\begin{aligned}
 16. \quad & \text{y-intercept} = -2; \text{ containing } (5, -3) \\
 & \text{Points are } (5, -3) \text{ and } (0, -2) \\
 & m = \frac{-2 - (-3)}{0 - 5} = \frac{1}{-5} = -\frac{1}{5} \\
 & y = mx + b \\
 & y = -\frac{1}{5}x - 2 \quad \text{or} \quad x + 5y = -10
 \end{aligned}$$

$$\begin{aligned}
 17. \quad & \text{Containing the points } (3, -4) \text{ and } (2, 1) \\
 & m = \frac{1 - (-4)}{2 - 3} = \frac{5}{-1} = -5 \\
 & y - y_1 = m(x - x_1) \\
 & y - (-4) = -5(x - 3) \\
 & y + 4 = -5x + 15 \\
 & y = -5x + 11 \quad \text{or} \quad 5x + y = 11
 \end{aligned}$$

$$\begin{aligned}
 18. \quad & \text{Parallel to } 2x - 3y = -4 \\
 & 2x - 3y = -4 \\
 & -3y = -2x - 4 \\
 & \frac{-3y}{-3} = \frac{-2x - 4}{-3} \\
 & y = \frac{2}{3}x + \frac{4}{3} \\
 & \text{Slope} = \frac{2}{3}; \text{ containing } (-5, 3) \\
 & y - y_1 = m(x - x_1) \\
 & y - 3 = \frac{2}{3}(x - (-5)) \\
 & y - 3 = \frac{2}{3}(x + 5) \\
 & y - 3 = \frac{2}{3}x + \frac{10}{3} \\
 & y = \frac{2}{3}x + \frac{19}{3} \quad \text{or} \quad 2x - 3y = -19
 \end{aligned}$$

$$\begin{aligned}
 19. \quad & \text{Perpendicular to } x + y = 2 \\
 & x + y = 2 \\
 & y = -x + 2 \\
 & \text{The slope of this line is } -1, \text{ so the slope of a line} \\
 & \text{perpendicular to it is } 1. \\
 & \text{Slope} = 1; \text{ containing } (4, -3) \\
 & y - y_1 = m(x - x_1) \\
 & y - (-3) = 1(x - 4) \\
 & y + 3 = x - 4 \\
 & y = x - 7 \quad \text{or} \quad x - y = 7
 \end{aligned}$$

Chapter 2: Graphs

20. $4x - 5y = -20$

$-5y = -4x - 20$

$y = \frac{4}{5}x + 4$

slope = $\frac{4}{5}$; y-intercept = 4

x-intercept: Let $y = 0$.

$4x - 5(0) = -20$

$4x = -20$

$x = -5$

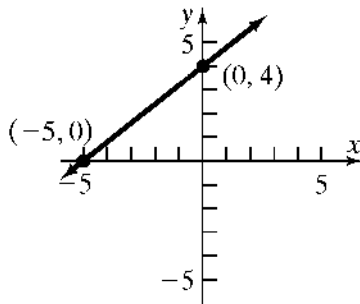

21. $\frac{1}{2}x - \frac{1}{3}y = -\frac{1}{6}$

$-\frac{1}{3}y = -\frac{1}{2}x - \frac{1}{6}$

$y = \frac{3}{2}x + \frac{1}{2}$

slope = $\frac{3}{2}$; y-intercept = $\frac{1}{2}$

x-intercept: Let $y = 0$.

$\frac{1}{2}x - \frac{1}{3}(0) = -\frac{1}{6}$

$\frac{1}{2}x = -\frac{1}{6}$

$x = -\frac{1}{3}$

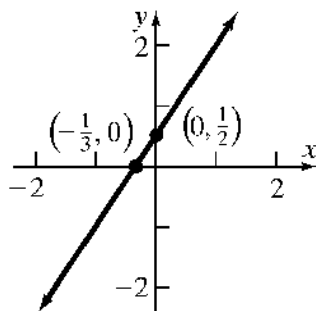

22. $2x - 3y = 12$

x-intercept:

$2x - 3(0) = 12$

$2x = 12$

$x = 6$

y-intercept:

$2(0) - 3y = 12$

$-3y = 12$

$y = -4$

The intercepts are (6, 0) and (0, -4).

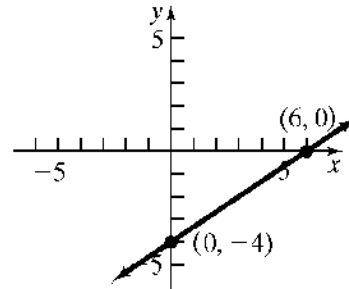

23. $\frac{1}{2}x + \frac{1}{3}y = 2$

x-intercept:

$\frac{1}{2}x + \frac{1}{3}(0) = 2$

$\frac{1}{2}x = 2$

$x = 4$

y-intercept:

$\frac{1}{2}(0) + \frac{1}{3}y = 2$

$\frac{1}{3}y = 2$

$y = 6$

The intercepts are (4, 0) and (0, 6).

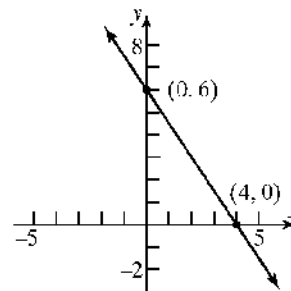

24. $y = x^3$

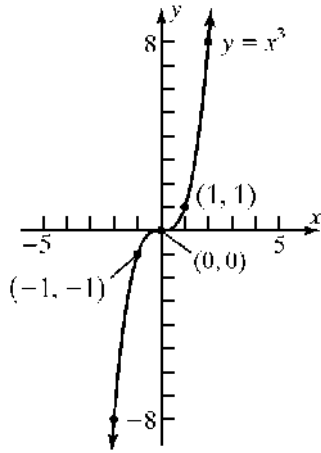

25. $y = \sqrt{x}$

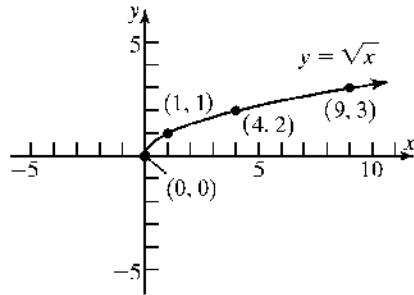

26. slope = $\frac{2}{3}$, containing the point (1, 2)

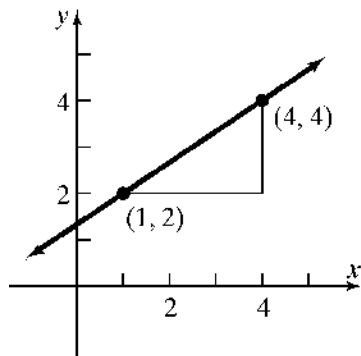

27. Find the distance between each pair of points.

$$d_{A,B} = \sqrt{(1-3)^2 + (1-4)^2} = \sqrt{4+9} = \sqrt{13}$$

$$d_{B,C} = \sqrt{(-2-1)^2 + (3-1)^2} = \sqrt{9+4} = \sqrt{13}$$

$$d_{A,C} = \sqrt{(-2-3)^2 + (3-4)^2} = \sqrt{25+1} = \sqrt{26}$$

Since $AB = BC$, triangle ABC is isosceles.

28. Given the points $A = (-2, 0)$, $B = (-4, 4)$, and $C = (8, 5)$.

a. Find the distance between each pair of points.

$$\begin{aligned} d(A,B) &= \sqrt{(-4 - (-2))^2 + (4 - 0)^2} \\ &= \sqrt{4 + 16} \\ &= \sqrt{20} = 2\sqrt{5} \end{aligned}$$

$$\begin{aligned} d(B,C) &= \sqrt{(8 - (-4))^2 + (5 - 4)^2} \\ &= \sqrt{144 + 1} \\ &= \sqrt{145} \end{aligned}$$

$$\begin{aligned} d(A,C) &= \sqrt{(8 - (-2))^2 + (5 - 0)^2} \\ &= \sqrt{100 + 25} \\ &= \sqrt{125} = 5\sqrt{5} \end{aligned}$$

$$\begin{aligned} [d(A,B)]^2 + [d(A,C)]^2 &= [d(B,C)]^2 \\ (\sqrt{20})^2 + (\sqrt{125})^2 &= (\sqrt{145})^2 \\ 20 + 125 &= 145 \\ 145 &= 145 \end{aligned}$$

The Pythagorean Theorem is satisfied, so this is a right triangle.

b. Find the slopes:

$$m_{AB} = \frac{4-0}{-4-(-2)} = \frac{4}{-2} = -2$$

$$m_{BC} = \frac{5-4}{8-(-4)} = \frac{1}{12}$$

$$m_{AC} = \frac{5-0}{8-(-2)} = \frac{5}{10} = \frac{1}{2}$$

Since $m_{AB} \cdot m_{AC} = -2 \cdot \frac{1}{2} = -1$, the sides AB and AC are perpendicular and the triangle is a right triangle.

29. Endpoints of the diameter are $(-3, 2)$ and $(5, -6)$. The center is at the midpoint of the diameter:

$$\text{Center: } \left(\frac{-3+5}{2}, \frac{2+(-6)}{2} \right) = (1, -2)$$

$$\begin{aligned} \text{Radius: } r &= \sqrt{(1 - (-3))^2 + (-2 - 2)^2} \\ &= \sqrt{16 + 16} \\ &= \sqrt{32} = 4\sqrt{2} \end{aligned}$$

Chapter 2: Graphs

$$\text{Equation: } (x-1)^2 + (y+2)^2 = (4\sqrt{2})^2$$

$$(x-1)^2 + (y+2)^2 = 32$$

$$30. \text{ slope of } \overline{AB} = \frac{1-5}{6-2} = -1$$

$$\text{slope of } \overline{AC} = \frac{-1-5}{8-2} = -1$$

Therefore, the points lie on a line.

$$31. \quad p = kB$$

$$854 = k(130,000)$$

$$k = \frac{854}{130,000} = \frac{427}{65,000}$$

Therefore, we have the equation $p = \frac{427}{65,000}B$.

If $B = 165,000$, then

$$p = \frac{427}{65,000}(165,000) = \$1083.92.$$

$$32. \quad w = \frac{k}{d^2}$$

$$200 = \frac{k}{3960^2}$$

$$k = (200)(3960^2) = 3,136,320,000$$

Therefore, we have the equation

$$w = \frac{3,136,320,000}{d^2}.$$

If $d = 3960 + 1 = 3961$ miles, then

$$w = \frac{3,136,320,000}{3961^2} \approx 199.9 \text{ pounds.}$$

$$33. \quad H = ksd$$

$$135 = k(7.5)(40)$$

$$135 = 300k$$

$$k = 0.45$$

So, we have the equation $H = 0.45sd$.

If $s = 12$ and $d = 35$, then

$$H = 0.45(12)(35) = 189 \text{ BTU}$$

Chapter 2 Test

$$\begin{aligned} 1. \quad d(P_1, P_2) &= \sqrt{(5-(-1))^2 + (-1-3)^2} \\ &= \sqrt{6^2 + (-4)^2} \\ &= \sqrt{36+16} \\ &= \sqrt{52} = 2\sqrt{13} \end{aligned}$$

2. The coordinates of the midpoint are:

$$\begin{aligned} (x, y) &= \left(\frac{x_1 + x_2}{2}, \frac{y_1 + y_2}{2} \right) \\ &= \left(\frac{-1+5}{2}, \frac{3+(-1)}{2} \right) \\ &= \left(\frac{4}{2}, \frac{2}{2} \right) \\ &= (2, 1) \end{aligned}$$

$$3. \quad \text{a. } m = \frac{y_2 - y_1}{x_2 - x_1} = \frac{-1-3}{5-(-1)} = \frac{-4}{6} = -\frac{2}{3}$$

b. If x increases by 3 units, y will decrease by 2 units.

$$4. \quad y^2 = x$$

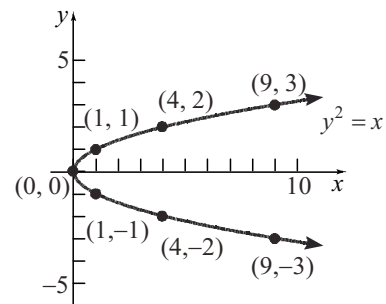

$$5. \quad x^2 + y = 9$$

$$\begin{array}{ll} \text{x-intercepts:} & \text{y-intercept:} \\ x^2 + 0 = 9 & (0)^2 + y = 9 \\ x^2 = 9 & y = 9 \\ x = \pm 3 & \end{array}$$

The intercepts are $(-3,0)$, $(3,0)$, and $(0,9)$.

Test x-axis symmetry: Let $y = -y$

$$\begin{aligned} x^2 + (-y) &= 9 \\ x^2 - y &= 9 \text{ different} \end{aligned}$$

Test y-axis symmetry: Let $x = -x$

$$(-x)^2 + y = 9$$

$$x^2 + y = 9 \text{ same}$$

Test origin symmetry: Let $x = -x$ and $y = -y$

$$(-x)^2 + (-y) = 9$$

$$x^2 - y = 9 \text{ different}$$

Therefore, the graph will have y-axis symmetry.

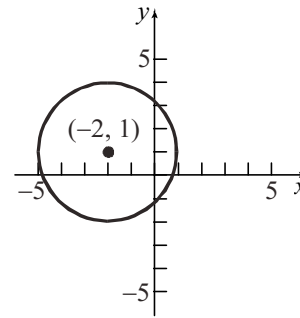

6. Slope = -2 ; containing $(3, -4)$

$$y - y_1 = m(x - x_1)$$

$$y - (-4) = -2(x - 3)$$

$$y + 4 = -2x + 6$$

$$y = -2x + 2$$

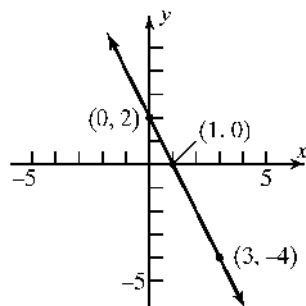

7. $(x - h)^2 + (y - k)^2 = r^2$

$$(x - 4)^2 + (y - (-3))^2 = 5^2$$

$$(x - 4)^2 + (y + 3)^2 = 25$$

General form: $(x - 4)^2 + (y + 3)^2 = 25$

$$x^2 - 8x + 16 + y^2 + 6y + 9 = 25$$

$$x^2 + y^2 - 8x + 6y = 0$$

8. $x^2 + y^2 + 4x - 2y - 4 = 0$

$$x^2 + 4x + y^2 - 2y = 4$$

$$(x^2 + 4x + 4) + (y^2 - 2y + 1) = 4 + 4 + 1$$

$$(x + 2)^2 + (y - 1)^2 = 3^2$$

Center: $(-2, 1)$; Radius = 3

9. $2x + 3y = 6$

$$3y = -2x + 6$$

$$y = -\frac{2}{3}x + 2$$

Parallel line

Any line parallel to $2x + 3y = 6$ has slope

$$m = -\frac{2}{3}. \text{ The line contains } (1, -1):$$

$$y - y_1 = m(x - x_1)$$

$$y - (-1) = -\frac{2}{3}(x - 1)$$

$$y + 1 = -\frac{2}{3}x + \frac{2}{3}$$

$$y = -\frac{2}{3}x - \frac{1}{3}$$

Perpendicular line

Any line perpendicular to $2x + 3y = 6$ has slope

$$m = \frac{3}{2}. \text{ The line contains } (0, 3):$$

$$y - y_1 = m(x - x_1)$$

$$y - 3 = \frac{3}{2}(x - 0)$$

$$y - 3 = \frac{3}{2}x$$

$$y = \frac{3}{2}x + 3$$

10. Let R = the resistance, l = length, and r = radius.

Then $R = k \cdot \frac{l}{r^2}$. Now, $R = 10$ ohms, when

$l = 50$ feet and $r = 6 \times 10^{-3}$ inch, so

Chapter 2: Graphs

$$10 = k \cdot \frac{50}{(6 \times 10^{-3})^2}$$

$$k = 10 \cdot \frac{(6 \times 10^{-3})^2}{50} = 7.2 \times 10^{-6}$$

Therefore, we have the equation

$$R = (7.2 \times 10^{-6}) \frac{l}{r^2}.$$

If $l = 100$ feet and $r = 7 \times 10^{-3}$ inch, then

$$R = (7.2 \times 10^{-6}) \frac{100}{(7 \times 10^{-3})^2} \approx 14.69 \text{ ohms.}$$

Chapter 2 Cumulative Review

1. $3x - 5 = 0$

$$3x = 5$$

$$x = \frac{5}{3}$$

The solution set is $\left\{\frac{5}{3}\right\}$.

2. $x^2 - x - 12 = 0$

$$(x - 4)(x + 3) = 0$$

$$x = 4 \text{ or } x = -3$$

The solution set is $\{-3, 4\}$.

3. $2x^2 - 5x - 3 = 0$

$$(2x + 1)(x - 3) = 0$$

$$x = -\frac{1}{2} \text{ or } x = 3$$

The solution set is $\left\{-\frac{1}{2}, 3\right\}$.

4. $x^2 - 2x - 2 = 0$

$$x = \frac{-(-2) \pm \sqrt{(-2)^2 - 4(1)(-2)}}{2(1)}$$

$$= \frac{2 \pm \sqrt{4+8}}{2}$$

$$= \frac{2 \pm \sqrt{12}}{2}$$

$$= \frac{2 \pm 2\sqrt{3}}{2}$$

$$= 1 \pm \sqrt{3}$$

The solution set is $\{1 - \sqrt{3}, 1 + \sqrt{3}\}$.

5. $x^2 + 2x + 5 = 0$

$$x = \frac{-2 \pm \sqrt{2^2 - 4(1)(5)}}{2(1)}$$

$$= \frac{-2 \pm \sqrt{4-20}}{2}$$

$$= \frac{-2 \pm \sqrt{-16}}{2}$$

No real solutions

6. $\sqrt{2x+1} = 3$

$$(\sqrt{2x+1})^2 = 3^2$$

$$2x+1=9$$

$$2x=8$$

$$x=4$$

Check: $\sqrt{2(4)+1} = 3?$

$$\sqrt{9} = 3?$$

$$3 = 3 \text{ True}$$

The solution set is $\{4\}$.

7. $|x - 2| = 1$

$$x - 2 = 1 \text{ or } x - 2 = -1$$

$$x = 3$$

$$x = 1$$

The solution set is $\{1, 3\}$.

8. $\sqrt{x^2 + 4x} = 2$
 $(\sqrt{x^2 + 4x})^2 = 2^2$
 $x^2 + 4x = 4$
 $x^2 + 4x - 4 = 0$
 $x = \frac{-4 \pm \sqrt{4^2 - 4(1)(-4)}}{2(1)} = \frac{-4 \pm \sqrt{16 + 16}}{2}$
 $= \frac{-4 \pm \sqrt{32}}{2} = \frac{-4 \pm 4\sqrt{2}}{2} = -2 \pm 2\sqrt{2}$

Check $x = -2 + 2\sqrt{2}$:
 $\sqrt{(-2 + 2\sqrt{2})^2 + 4(-2 + 2\sqrt{2})} = 2?$
 $\sqrt{4 - 8\sqrt{2} + 8 - 8 + 8\sqrt{2}} = 2?$
 $\sqrt{4} = 2$ True

Check $x = -2 - 2\sqrt{2}$:
 $\sqrt{(-2 - 2\sqrt{2})^2 + 4(-2 - 2\sqrt{2})} = 2?$
 $\sqrt{4 + 8\sqrt{2} + 8 - 8 - 8\sqrt{2}} = 2?$
 $\sqrt{4} = 2$ True

The solution set is $\{-2 - 2\sqrt{2}, -2 + 2\sqrt{2}\}$.

9. $x^2 = -9$
 $x = \pm\sqrt{-9}$
 $x = \pm 3i$
 The solution set is $\{-3i, 3i\}$.

10. $x^2 - 2x + 5 = 0$
 $x = \frac{-(-2) \pm \sqrt{(-2)^2 - 4(1)(5)}}{2(1)} = \frac{2 \pm \sqrt{4 - 20}}{2}$
 $= \frac{2 \pm \sqrt{-16}}{2} = \frac{2 \pm 4i}{2} = 1 \pm 2i$

The solution set is $\{1 - 2i, 1 + 2i\}$.

11. $2x - 3 \leq 7$
 $2x \leq 10$
 $x \leq 5$
 $\{x | x \leq 5\}$ or $(-\infty, 5]$

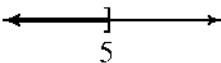

12. $-1 < x + 4 < 5$
 $-5 < x < 1$
 $\{x | -5 < x < 1\}$ or $(-5, 1)$

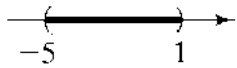

13. $|x - 2| \leq 1$
 $-1 \leq x - 2 \leq 1$
 $1 \leq x \leq 3$
 $\{x | 1 \leq x \leq 3\}$ or $[1, 3]$

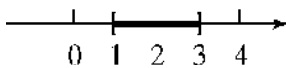

14. $|2 + x| > 3$
 $2 + x < -3$ or $2 + x > 3$
 $x < -5$ or $x > 1$
 $\{x | x < -5 \text{ or } x > 1\}$ or $(-\infty, -5) \cup (1, \infty)$

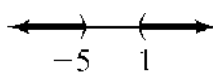

15. $d(P, Q) = \sqrt{(-1 - 4)^2 + (3 - (-2))^2}$
 $= \sqrt{(-5)^2 + (5)^2}$
 $= \sqrt{25 + 25}$
 $= \sqrt{50} = 5\sqrt{2}$
 Midpoint $= \left(\frac{-1 + 4}{2}, \frac{3 + (-2)}{2}\right) = \left(\frac{3}{2}, \frac{1}{2}\right)$

16. $y = x^3 - 3x + 1$

a. $(-2, -1)$:
 $(-2)^3 - (3)(-2) + 1 = -8 + 6 + 1 = -1$
 $(-2, -1)$ is on the graph.

b. $(2, 3)$:
 $(2)^3 - (3)(2) + 1 = 8 - 6 + 1 = 3$
 $(2, 3)$ is on the graph.

c. $(3, 1)$:
 $(3)^3 - (3)(3) + 1 = 27 - 9 + 1 = 19 \neq 1$
 $(3, 1)$ is not on the graph.

Chapter 2: Graphs

17. $y = x^3$

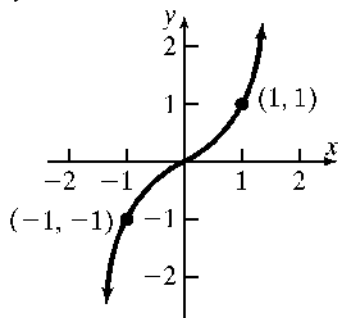

18. The points $(-1,4)$ and $(2,-2)$ are on the line.

$$\text{Slope} = \frac{-2-4}{2-(-1)} = \frac{-6}{3} = -2$$

$$y - y_1 = m(x - x_1)$$

$$y - 4 = -2(x - (-1))$$

$$y - 4 = -2(x + 1)$$

$$y = -2x - 2 + 4$$

$$y = -2x + 2$$

19. Perpendicular to $y = 2x + 1$; Contains $(3,5)$

$$\text{Slope of perpendicular} = -\frac{1}{2}$$

$$y - y_1 = m(x - x_1)$$

$$y - 5 = -\frac{1}{2}(x - 3)$$

$$y - 5 = -\frac{1}{2}x + \frac{3}{2}$$

$$y = -\frac{1}{2}x + \frac{13}{2}$$

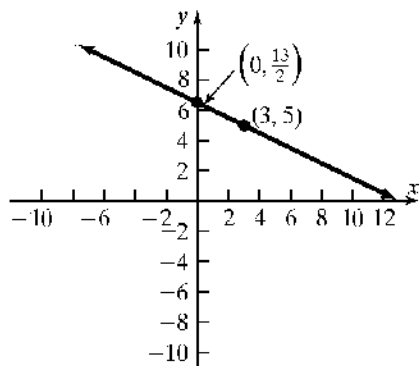

20. $x^2 + y^2 - 4x + 8y - 5 = 0$

$$x^2 - 4x + y^2 + 8y = 5$$

$$(x^2 - 4x + 4) + (y^2 + 8y + 16) = 5 + 4 + 16$$

$$(x - 2)^2 + (y + 4)^2 = 25$$

$$(x - 2)^2 + (y + 4)^2 = 5^2$$

Center: $(2, -4)$; Radius = 5

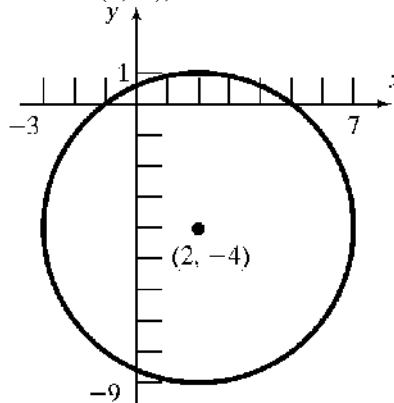

Chapter 2 Project

Internet-based Project