

Exam

Name _____

MULTIPLE CHOICE. Choose the one alternative that best completes the statement or answers the question.
Determine the intervals of the domain over which the function is continuous.

1)

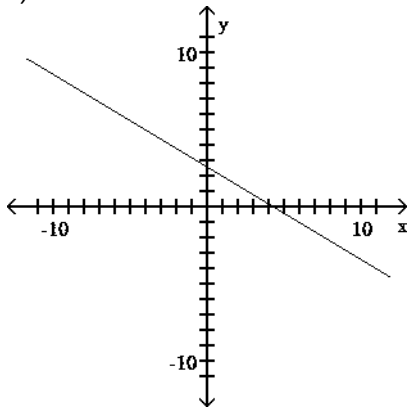

1) _____

- A) $(-\infty, \frac{13}{3}]$ B) $[0, \infty)$ C) $[\frac{13}{3}, \infty)$ D) $(-\infty, \infty)$

2)

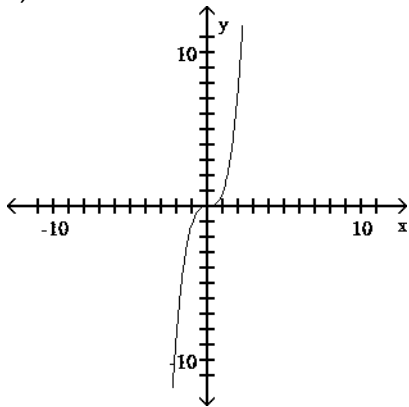

2) _____

- A) $[0, \infty)$ B) $(-\infty, \infty)$ C) $(0, \infty)$ D) $(-\infty, 0]$

3)

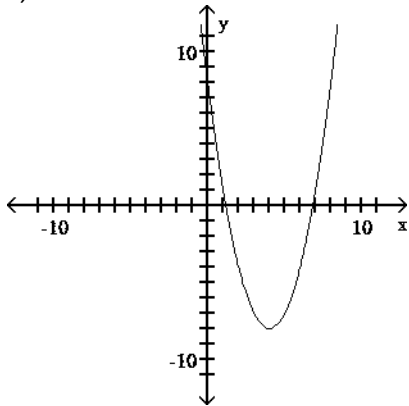

3) _____

- A) $(0, \infty)$ B) $(-\infty, 0); (0, \infty)$ C) $(-\infty, 0)$ D) $(-\infty, \infty)$

4)

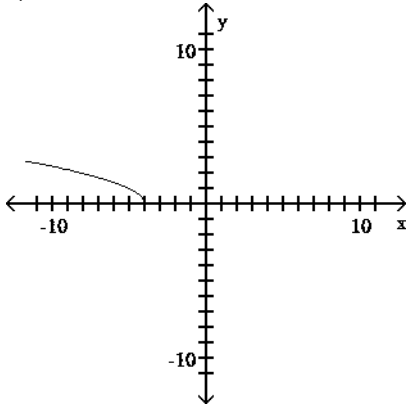

4) _____

- A) $(-\infty, \infty)$ B) $(-\infty, -4); (-4, \infty)$ C) $(-4, \infty)$ D) $(-\infty, -4]$

5)

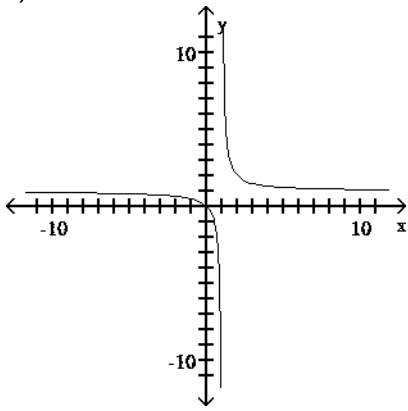

5) _____

- A) $(-\infty, 1); (1, \infty)$ B) $(-\infty, \infty)$ C) $(-\infty, -1); (-1, \infty)$ D) $(0, \infty)$

6)

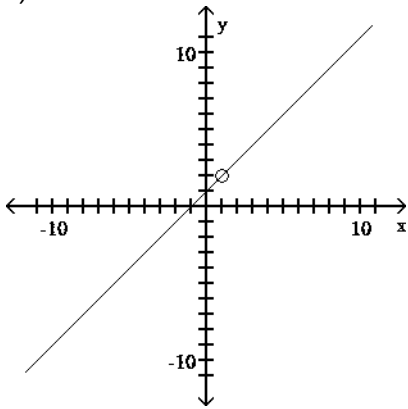

6) _____

- A) $(-\infty, 1); (1, \infty)$ B) $(-\infty, -1); (-1, \infty)$ C) $(-\infty, \infty)$ D) $(-\infty, 2); (2, \infty)$

7)

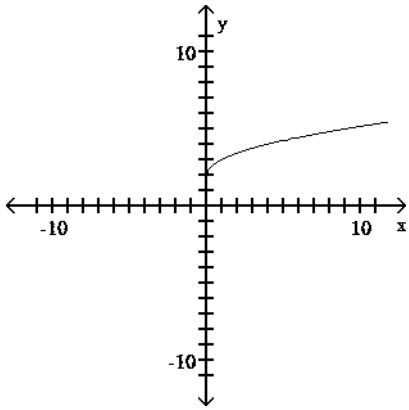

7) _____

- A) $[0, \infty)$ B) $[-2, \infty)$ C) $[2, \infty)$ D) $[0, 2)$

8)

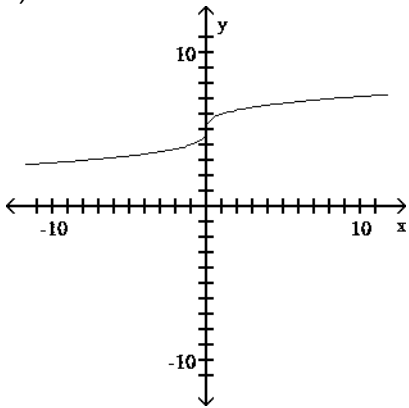

8) _____

- A) $(0, 5)$ B) $(5, \infty)$ C) $(-\infty, \infty)$ D) $(0, \infty)$

Determine the intervals on which the function is increasing, decreasing, and constant.

9)

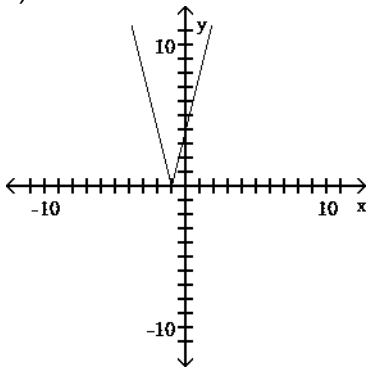

9) _____

- A) Increasing on $(1, \infty)$; Decreasing on $(-\infty, 1)$
 B) Increasing on $(-\infty, -1)$; Decreasing on $(-1, \infty)$
 C) Increasing on $(-1, \infty)$; Decreasing on $(-\infty, -1)$
 D) Increasing on $(-\infty, 1)$; Decreasing on $(1, \infty)$

10)

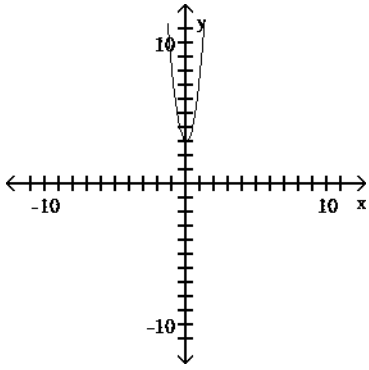

10) _____

- A) Increasing on $(0, \infty)$; Decreasing on $(-\infty, 0)$
- B) Increasing on $(\infty, 0)$; Decreasing on $(0, -\infty)$
- C) Increasing on $(-\infty, 0)$; Decreasing on $(-\infty, 0)$
- D) Increasing on $(-\infty, 0)$; Decreasing on $(0, \infty)$

11)

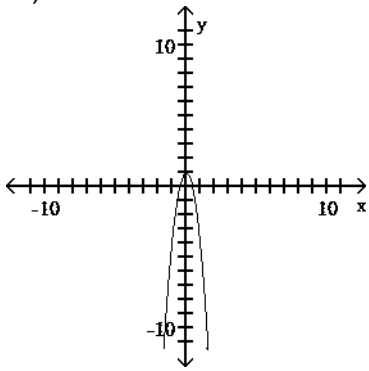

11) _____

- A) Increasing on $(0, \infty)$; Decreasing on $(-\infty, 0)$
- B) Increasing on $(\infty, 0)$; Decreasing on $(0, -\infty)$
- C) Increasing on $(-\infty, 0)$; Decreasing on $(0, \infty)$
- D) Increasing on $(-\infty, 0)$; Decreasing on $(-\infty, 0)$

12)

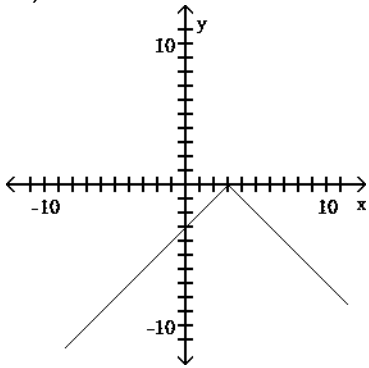

12) _____

- A) Increasing on $(3, \infty)$; Decreasing on $(3, \infty)$
- B) Increasing on $(3, \infty)$; Decreasing on $(-\infty, 3)$
- C) Increasing on $(-\infty, 3)$; Decreasing on $(-\infty, 3)$
- D) Increasing on $(-\infty, 3)$; Decreasing on $(3, \infty)$

13)

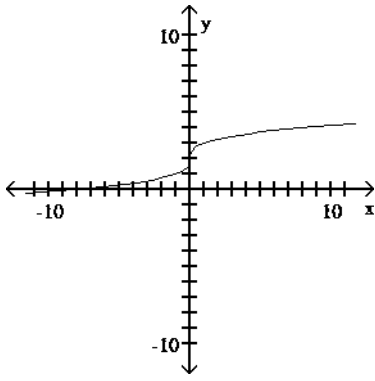

13) _____

- A) Increasing on $(-\infty, \infty)$ B) Increasing on $(0, \infty)$; Decreasing on $(-\infty, 0)$
 C) Increasing on $(-\infty, 0)$; Decreasing on $(0, \infty)$ D) Decreasing on $(-\infty, \infty)$

14)

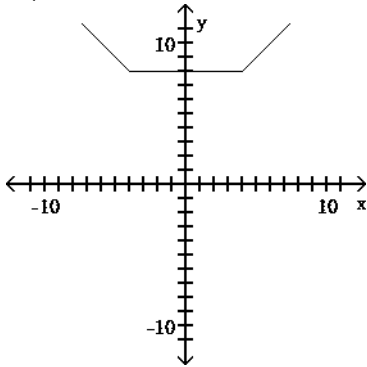

14) _____

- A) Increasing on $(-\infty, 4)$; Decreasing on $(-\infty, -4)$; Constant on $(4, \infty)$
 B) Increasing on $(4, \infty)$; Decreasing on $(-4, \infty)$; Constant on $(-4, 4)$
 C) Increasing on $(-\infty, 4)$; Decreasing on $(-4, \infty)$; Constant on $(4, \infty)$
 D) Increasing on $(4, \infty)$; Decreasing on $(-\infty, -4)$; Constant on $(-4, 4)$

15)

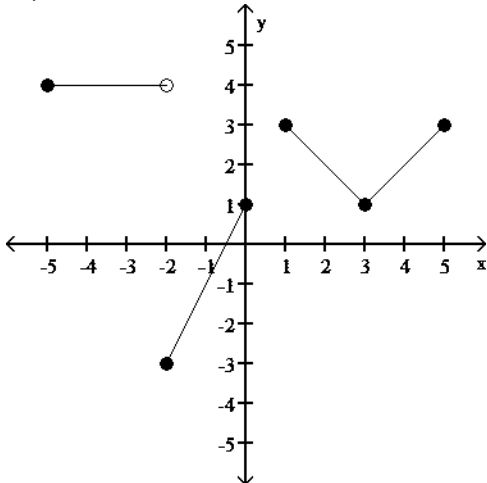

15) _____

- A) Increasing on $(-1, 0)$ and $(3, 5)$; Decreasing on $(0, 3)$; Constant on $(-5, -3)$
 B) Increasing on $(1, 3)$; Decreasing on $(-2, 0)$ and $(3, 5)$; Constant on $(2, 5)$
 C) Increasing on $(-2, 0)$ and $(3, 4)$; Decreasing on $(-5, -2)$ and $(1, 3)$
 D) Increasing on $(-2, 0)$ and $(3, 5)$; Decreasing on $(1, 3)$; Constant on $(-5, -2)$

16)

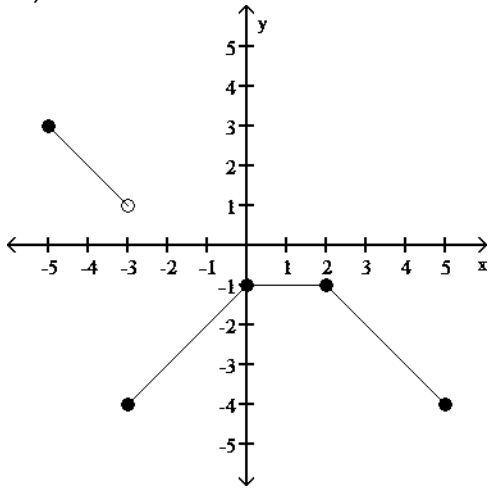

16) _____

- A) Increasing on $(-5, -3)$ and $(2, 5)$; Decreasing on $(-3, 0)$; Constant on $(0, 2)$
- B) Increasing on $(-3, -1)$; Decreasing on $(-5, -2)$ and $(2, 4)$; Constant on $(-1, 2)$
- C) Increasing on $(-3, 1)$; Decreasing on $(-5, -3)$ and $(0, 5)$; Constant on $(1, 2)$
- D) Increasing on $(-3, 0)$; Decreasing on $(-5, -3)$ and $(2, 5)$; Constant on $(0, 2)$

Find the domain and the range for the function.

17)

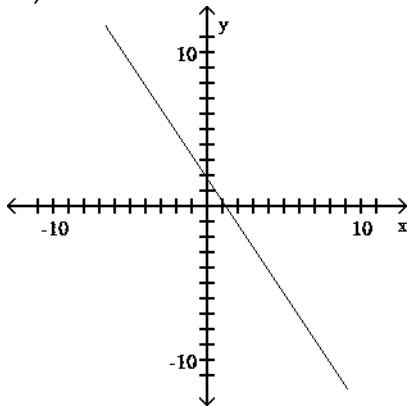

17) _____

- A) D: $[0, \infty)$, R: $[-\frac{7}{4}, \infty)$
- B) D: $[\frac{7}{6}, \infty)$, R: $(-\infty, 0]$
- C) D: $[\frac{7}{6}, \infty)$, R: $[0, \infty)$
- D) D: $(-\infty, \infty)$, R: $(-\infty, \infty)$

18)

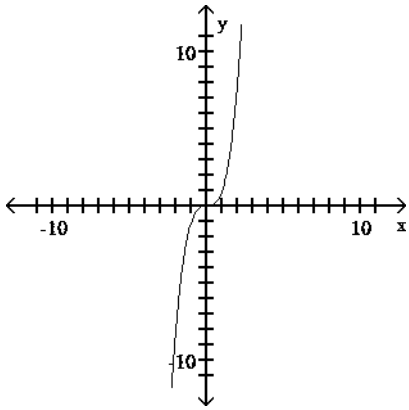

18) _____

- A) D: $(-\infty, \infty)$, R: $(-\infty, \infty)$ B) D: $(0, \infty)$, R: $(0, \infty)$
 C) D: $(-\infty, 0]$, R: $(-\infty, 0]$ D) D: $[0, \infty)$, R: $[0, \infty)$

19)

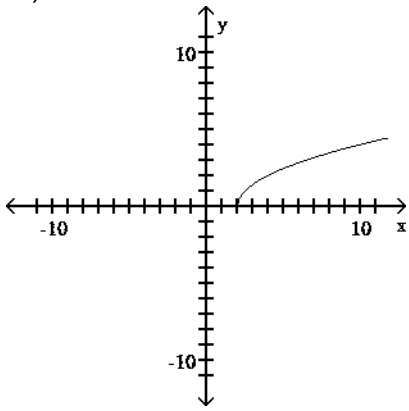

19) _____

- A) D: $(0, \infty)$, R: $(-\infty, 0]$ B) D: $[0, \infty)$, R: $(-\infty, 0]$
 C) D: $(2, \infty)$, R: $[0, \infty)$ D) D: $[2, \infty)$, R: $[0, \infty)$

20)

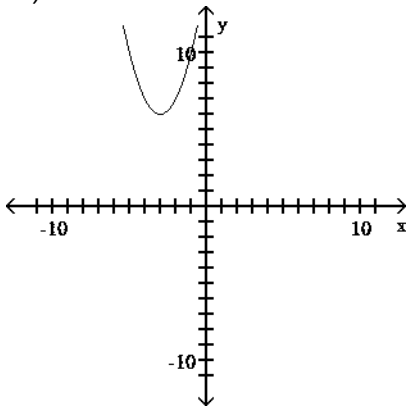

20) _____

- A) D: $(-\infty, \infty)$, R: $[6, \infty)$ B) D: $(0, \infty)$, R: $(-\infty, 3]$
 C) D: $(-\infty, \infty)$, R: $(-\infty, \infty)$ D) D: $(-\infty, 0)$, R: $(-\infty, 0)$

21)

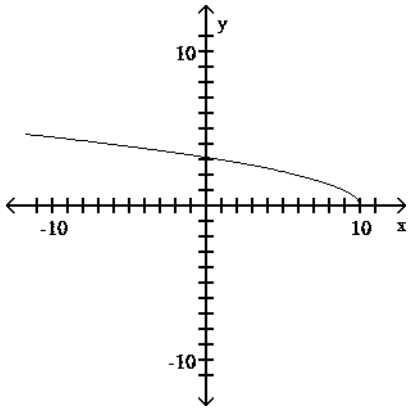

21) _____

- A) D: $(-\infty, 10]$, R: $[0, \infty)$ B) D: $(-\infty, 10]$, R: $[10, \infty)$
 C) D: $(-\infty, \infty)$, R: $[0, \infty)$ D) D: $[0, \infty)$, R: $(-\infty, 10]$

22)

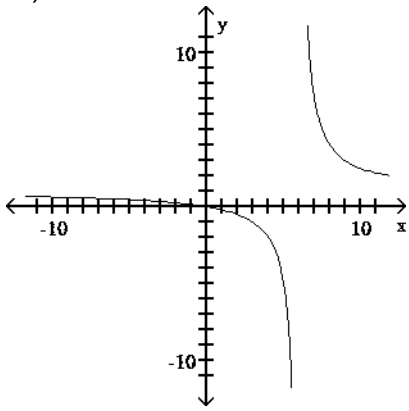

22) _____

- A) D: $(-\infty, -6) \cup (-6, \infty)$, R: $(-\infty, \infty)$ B) D: $(0, \infty)$, R: $(1, \infty)$
 C) D: $(-\infty, \infty)$, R: $(-\infty, \infty)$ D) D: $(-\infty, 6) \cup (6, \infty)$, R: $(-\infty, 1) \cup (1, \infty)$

23)

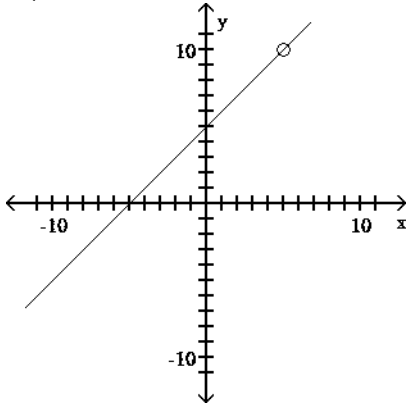

23) _____

- A) D: $(-\infty, 5) \cup (5, \infty)$, R: $(-\infty, 10) \cup (10, \infty)$ B) D: $(-\infty, 10) \cup (10, \infty)$, R: $(-\infty, 5) \cup (5, \infty)$
 C) D: $(-\infty, \infty)$, R: $(-\infty, \infty)$ D) D: $(-\infty, -5) \cup (-5, \infty)$, R: $(-\infty, -10) \cup (-10, \infty)$

24)

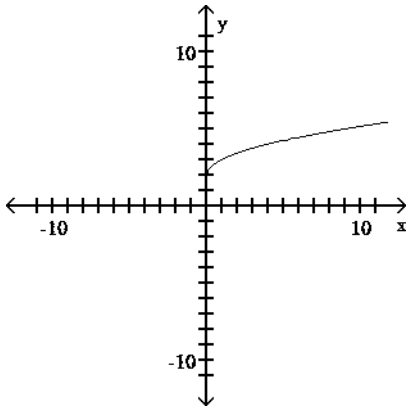

24) _____

- A) D: $[2, \infty)$, R: $[0, \infty)$ B) D: $[0, \infty)$, R: $[2, \infty)$
 C) D: $[0, \infty)$, R: $[0, \infty)$ D) D: $[-2, \infty)$, R: $(-\infty, 0]$

25)

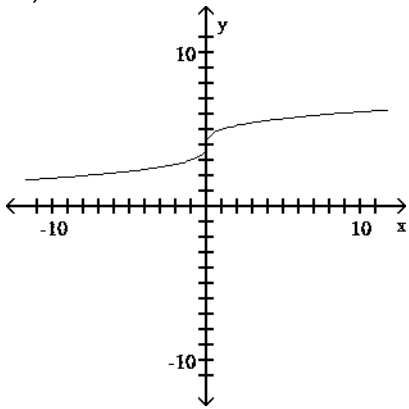

25) _____

- A) D: $(4, \infty)$, R: $(-\infty, 0]$ B) D: $(-\infty, \infty)$, R: $(-\infty, \infty)$
 C) D: $(4, \infty)$, R: $[0, \infty)$ D) D: $(0, \infty)$, R: $[0, \infty)$

Determine if the function is increasing or decreasing over the interval indicated.

26) $f(x) = 7x - 5$; $(-\infty, \infty)$ 26) _____

- A) Increasing B) Decreasing

27) $f(x) = \frac{1}{4}x^2 - \frac{1}{2}x$; $(1, \infty)$ 27) _____

- A) Increasing B) Decreasing

28) $f(x) = x^2 - 2x + 1$; $(1, \infty)$ 28) _____

- A) Increasing B) Decreasing

29) $f(x) = (x^2 - 9)^2$; $(3, \infty)$ 29) _____

- A) Increasing B) Decreasing

30) $f(x) = \frac{1}{x^2 + 1}$; $(-\infty, 0)$ 30) _____

- A) Increasing B) Decreasing

31) $f(x) = \sqrt{4-x}$; $(-\infty, 4)$ 31) _____

- A) Increasing B) Decreasing

32) $f(x) = |x - 8|$; $(-\infty, 8)$ 32) _____

- A) Increasing B) Decreasing

33) $f(x) = \frac{1}{x^2} + 7$; $(0, \infty)$ 33) _____

- A) Increasing B) Decreasing

34) $f(x) = -\sqrt{x+3}$; $(-3, \infty)$ 34) _____

- A) Increasing B) Decreasing

Determine if the graph is symmetric with respect to the x-axis, y-axis, or origin.

35)

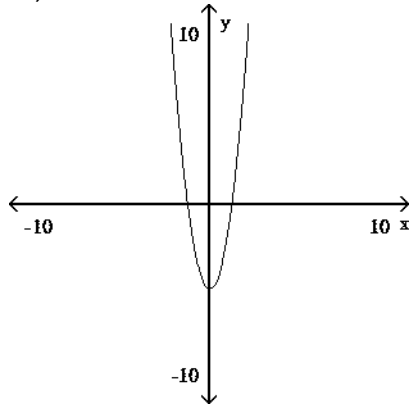

35) _____

- A) y-axis, origin B) y-axis C) Origin D) x-axis, origin

36)

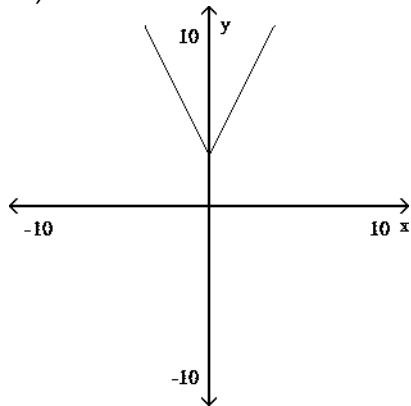

36) _____

- A) x-axis B) y-axis C) y-axis, origin D) x-axis, origin

37)

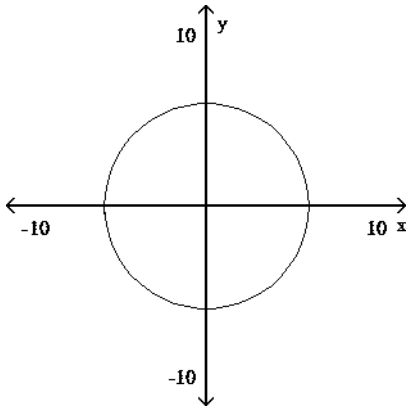

37) _____

- A) x-axis, origin
- B) Origin
- C) x-axis
- D) x-axis, y-axis, origin

38)

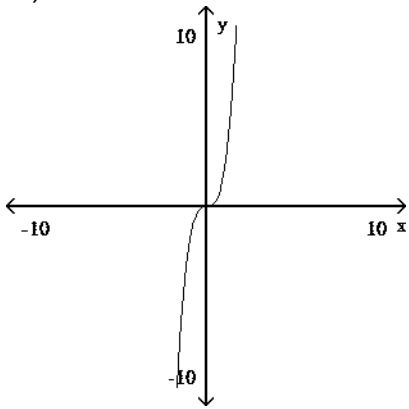

38) _____

- A) y-axis
- B) Origin
- C) x-axis
- D) x-axis, origin

39)

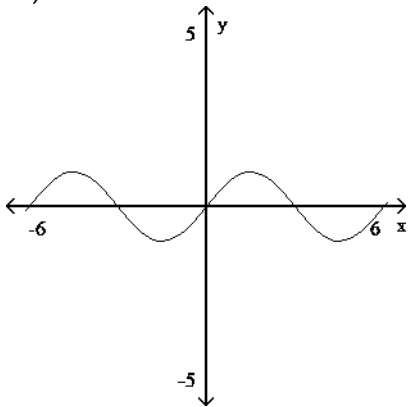

39) _____

- A) y-axis
- B) No symmetry
- C) x-axis
- D) Origin

Based on the ordered pairs seen in the pair of tables, make a conjecture as to whether the function defined in Y_1 is even, odd, or neither even nor odd.

40)

X	Y ₁	
0	0	
1	-3	
2	-6	
3	-9	
4	-12	
5	-15	
6	-18	
X=0		

X	Y ₁	
-6	18	
-5	15	
-4	12	
-3	9	
-2	6	
-1	3	
0	0	
X=-6		

40) _____

A) Odd B) Neither even nor odd C) Even

41)

X	Y ₁	
0	0	
1	1	
2	16	
3	81	
4	256	
5	625	
6	1296	
X=0		

X	Y ₁	
-6	1296	
-5	625	
-4	256	
-3	81	
-2	16	
-1	1	
0	0	
X=-6		

41) _____

A) Odd B) Even C) Neither even nor odd

42)

X	Y ₁	
0	0	
1	-1	
2	12	
3	75	
4	248	
5	615	
6	1284	
X=0		

X	Y ₁	
-6	1308	
-5	635	
-4	264	
-3	87	
-2	20	
-1	3	
0	0	
X=-6		

42) _____

A) Even B) Neither even nor odd C) Odd

43)

X	Y ₁	
0	0	
1	1	
2	4	
3	9	
4	16	
5	25	
6	36	
X=0		

X	Y ₁	
-6	36	
-5	25	
-4	16	
-3	9	
-2	4	
-1	1	
0	0	
X=-6		

43) _____

A) Even B) Neither even nor odd C) Odd

44)

X	Y ₁	
0	-3	
1	-2	
2	1	
3	6	
4	13	
5	22	
6	33	
X=0		

X	Y ₁	
-6	33	
-5	22	
-4	13	
-3	6	
-2	1	
-1	-2	
0	-3	
X=-6		

44) _____

A) Odd B) Even C) Neither even nor odd

45)

X	Y ₁	
0	-4	
1	-3	
2	4	
3	23	
4	60	
5	121	
6	212	
X=0		

X	Y ₁	
-6	-220	
-5	-129	
-4	-68	
-3	-31	
-2	-12	
-1	-5	
0	-4	
X=-6		

45) _____

A) Even B) Neither even nor odd C) Odd

46)

X	Y ₁	
0	2	
1	2	
2	4	
3	8	
4	14	
5	22	
6	32	
X=0		

X	Y ₁	
-6	44	
-5	32	
-4	22	
-3	14	
-2	8	
-1	4	
0	2	
X=-6		

46) _____

A) Even B) Odd C) Neither even nor odd

47)

X	Y ₁	
0	0	
1	4	
2	8	
3	12	
4	16	
5	20	
6	24	
X=0		

X	Y ₁	
-6	-24	
-5	-20	
-4	-16	
-3	-12	
-2	-8	
-1	-4	
0	0	
X=-6		

47) _____

A) Odd B) Neither even nor odd C) Even

48)

X	Y ₁	
0	0	
1	-2	
2	-8	
3	-18	
4	-32	
5	-50	
6	-72	
X=0		

X	Y ₁	
-6	-72	
-5	-50	
-4	-32	
-3	-18	
-2	-8	
-1	-2	
0	0	
X=-6		

48) _____

A) Neither even nor odd B) Even C) Odd

49)

X	Y ₁	
0	0	
1	2	
2	6	
3	12	
4	20	
5	30	
6	40	
X=0		

X	Y ₁	
-6	30	
-5	20	
-4	12	
-3	6	
-2	2	
-1	0	
0	0	
X=-6		

49) _____

- A) Neither even nor odd B) Odd C) Even

Determine whether the function is even, odd, or neither.

50) $f(x) = 4x^2 - 550$ _____

- A) Even B) Odd C) Neither

51) $f(x) = (x + 9)(x + 8)$ 51) _____

- A) Even B) Odd C) Neither

52) $f(x) = -5x^3 + 7x$ 52) _____

- A) Even B) Odd C) Neither

53) $f(x) = 4x^5 + 4x^3$ 53) _____

- A) Even B) Odd C) Neither

54) $f(x) = -0.88x^2 + |x| - 9$ 54) _____

- A) Even B) Odd C) Neither

55) $f(x) = -5x^4 + 8x + 6$ 55) _____

- A) Even B) Odd C) Neither

56) $f(x) = |x^2 + x|$ 56) _____

- A) Even B) Odd C) Neither

57) $f(x) = x^3 - \frac{1}{x}$ 57) _____

- A) Even B) Odd C) Neither

Determine whether the graph of the given function is symmetric with respect to the y-axis, symmetric with respect to the origin, or neither.

58) $f(x) = -5x^2 - 3$ 58) _____

- A) y-axis B) Origin C) Neither

59) $f(x) = |4x| + 5$ 59) _____

- A) y-axis B) Origin C) Neither

60) $f(x) = -4x^3$ 60) _____

- A) y-axis B) Origin C) Neither

61) $f(x) = 4x^2 + 5$ 61) _____

- A) y-axis B) Origin C) Neither

62) $f(x) = -2x^3 + 2x$ 62) _____

- A) y-axis B) Origin C) Neither

63) $f(x) = 7x^5 - 6x^3$ 63) _____

- A) y-axis B) Origin C) Neither

64) $f(x) = 0.44x^2 + |x| - 7$ 64) _____

- A) y-axis B) Origin C) Neither

65) $f(x) = -3x^4 + 4x + 8$ 65) _____

- A) y-axis B) Origin C) Neither

66) $f(x) = x + \frac{1}{x^6}$ 66) _____

- A) y-axis B) Origin C) Neither

Provide an appropriate response.

67) True or False: The function $y = \frac{x^2 - 2^2}{x - 2}$ is continuous at $x = 2$. 67) _____

- A) False B) True

68) Sketch the graph of $f(x) = -x^2$. At which of these points is the function decreasing? 68) _____

- A) -4 B) 2 C) -2 D) 0

69) True or False: A continuous function cannot be drawn without lifting the pencil from the paper. 69) _____

- A) False B) True

70) What symmetry does the graph of $y = f(x)$ exhibit?

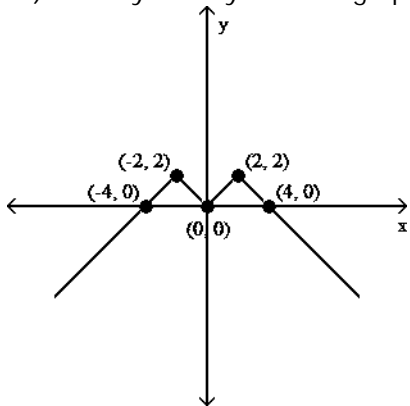

70) _____

- A) Origin B) y-axis C) x-axis D) No symmetry

71) What symmetry does the graph of $y = f(x)$ exhibit?

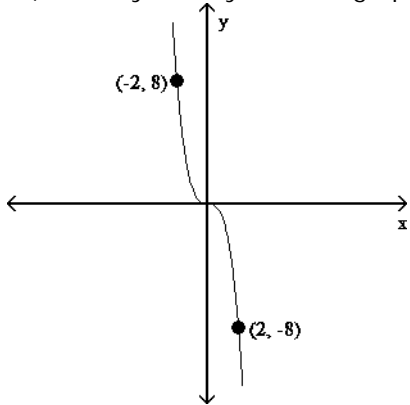

71) _____

- A) x-axis B) Origin C) y-axis D) No symmetry

72) Complete the table if f is an even function.

x	-4	-2	-1	1	2	4
$f(x)$	7	4	3			

72) _____

- A)

x	-4	-2	-1	1	2	4
$f(x)$	7	4	3	-3	4	-7

 B)

x	-4	-2	-1	1	2	4
$f(x)$	7	4	3	-7	4	-3
- C)

x	-4	-2	-1	1	2	4
$f(x)$	7	4	3	7	4	3

 D)

x	-4	-2	-1	1	2	4
$f(x)$	7	4	3	3	4	7

SHORT ANSWER. Write the word or phrase that best completes each statement or answers the question.

73) Complete the right half of the graph of $y = f(x)$ for each of the following conditions:

(i) f is odd.

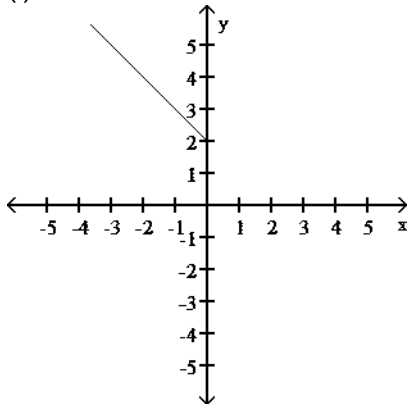

(ii) f is even.

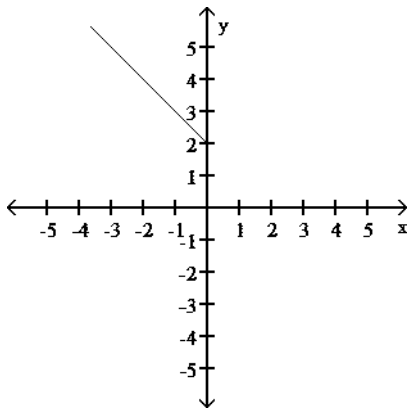

73) _____

- 1) D
- 2) B
- 3) D
- 4) D
- 5) A
- 6) A
- 7) A
- 8) C
- 9) C
- 10) A
- 11) C
- 12) D
- 13) A
- 14) D
- 15) D
- 16) D
- 17) D
- 18) A
- 19) D
- 20) A
- 21) A
- 22) D
- 23) A
- 24) B
- 25) B
- 26) A
- 27) A
- 28) A
- 29) A
- 30) A
- 31) B
- 32) B
- 33) B
- 34) B
- 35) B
- 36) B
- 37) D
- 38) B
- 39) D
- 40) A
- 41) B
- 42) B
- 43) A
- 44) B
- 45) B
- 46) C
- 47) A
- 48) B
- 49) A
- 50) A
- 51) C

- 52) B
- 53) B
- 54) A
- 55) C
- 56) C
- 57) B
- 58) A
- 59) A
- 60) B
- 61) A
- 62) B
- 63) B
- 64) A
- 65) C
- 66) C
- 67) A
- 68) B
- 69) A
- 70) B
- 71) B
- 72) D

73) (i) f is odd.

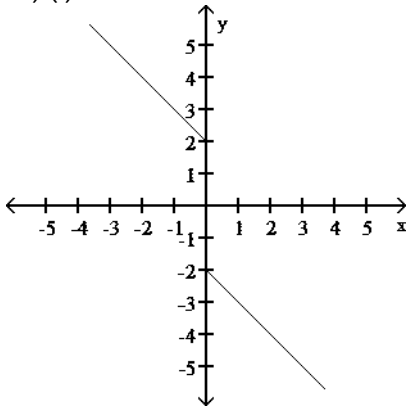

(ii) f is even.

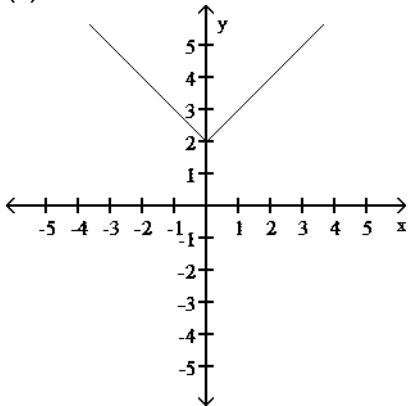

Exam

Name _____

MULTIPLE CHOICE. Choose the one alternative that best completes the statement or answers the question.

Write an equation that results in the indicated translation.

1) The squaring function, shifted 5 units upward 1) _____

- A) $y = \frac{x^2}{5}$ B) $y = x^2 + 5$ C) $y = 5x^2$ D) $y = x^2 - 5$

2) The absolute value function, shifted 8 units to the left 2) _____

- A) $y = |x + 8|$ B) $y = |x - 8|$ C) $y = |x| - 8$ D) $y = |x| + 8$

3) The absolute value function, shifted 9 units upward 3) _____

- A) $y = |x| + 9$ B) $y = |x| - 9$ C) $y = |x + 9|$ D) $y = |x - 9|$

4) The square root function, shifted 8 units to the right 4) _____

- A) $y = \sqrt{x} - 8$ B) $y = \sqrt{x + 8}$ C) $y = \sqrt{x - 8}$ D) $y = \sqrt{x} + 8$

5) The square root function, shifted 5 units to the left 5) _____

- A) $y = \sqrt{x} + 5$ B) $y = \sqrt{x - 5}$ C) $y = \sqrt{x + 5}$ D) $y = \sqrt{x} - 5$

6) The square root function, shifted 7 units upward 6) _____

- A) $y = \sqrt{x + 7}$ B) $y = \sqrt{x} + 7$ C) $y = \sqrt{x} - 7$ D) $y = \sqrt{x - 7}$

7) The square root function, shifted 5 units downward 7) _____

- A) $y = \sqrt{x - 5}$ B) $y = \sqrt{x + 5}$ C) $y = \sqrt{x} + 5$ D) $y = \sqrt{x} - 5$

Use translations of one of the basic functions to sketch a graph of $y = f(x)$ by hand.

8) $y = x^2 - 4$

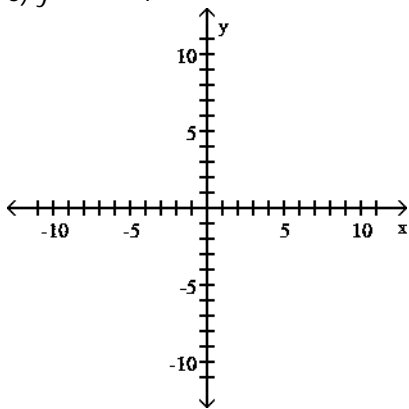

8) _____

A)

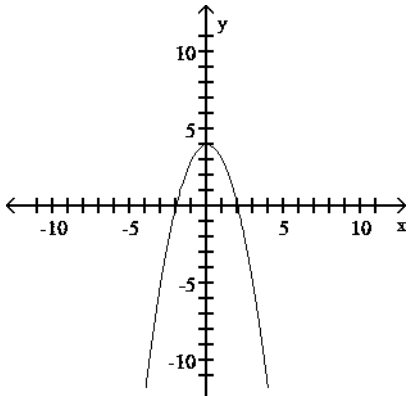

B)

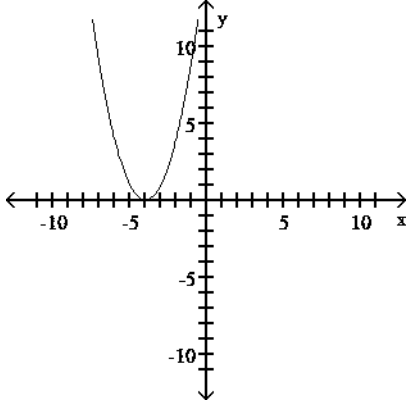

C)

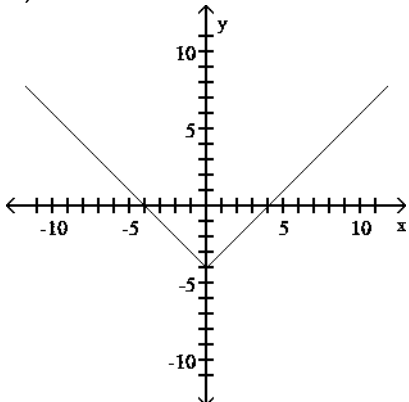

D)

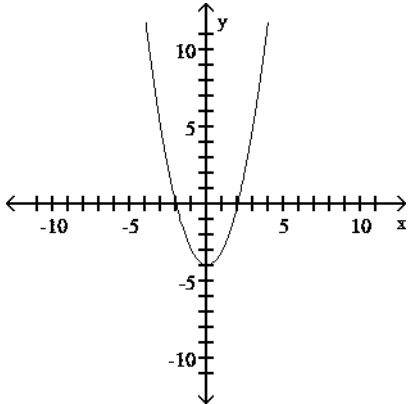

9) $y = |x - 3|$

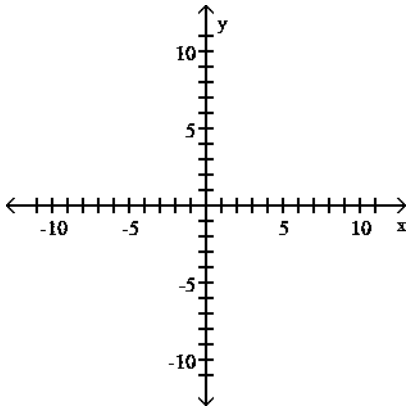

9) _____

A)

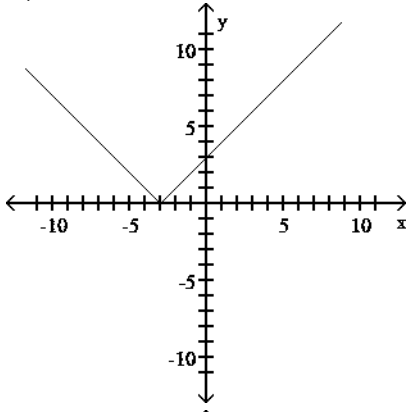

B)

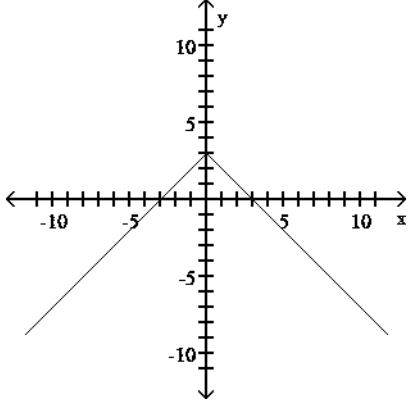

C)

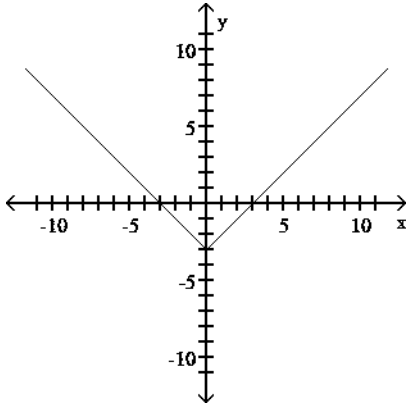

D)

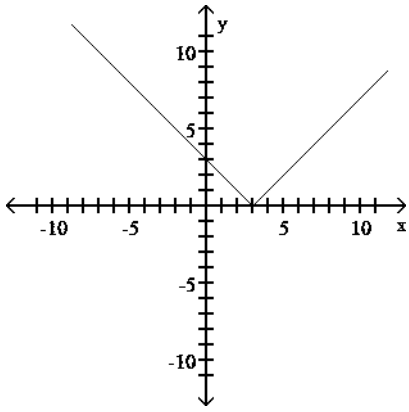

10) $y = x^3 + 1$

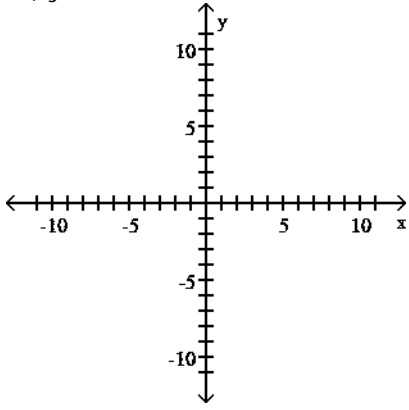

10) _____

A)

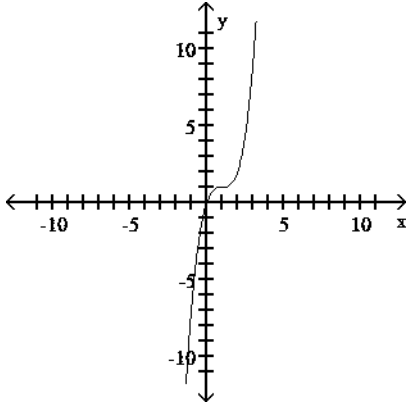

B)

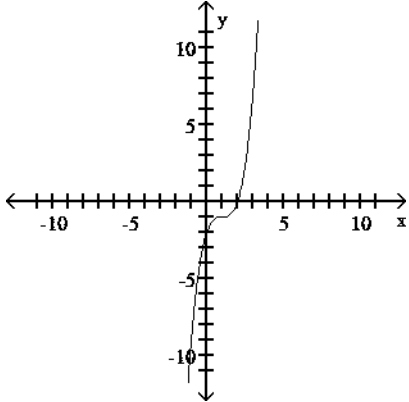

C)

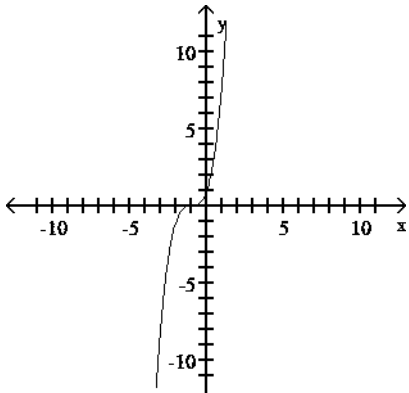

D)

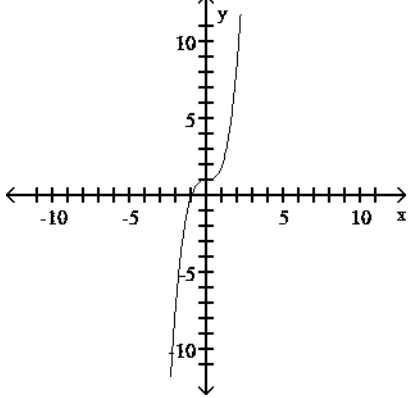

11) $y = (x + 2)^3$

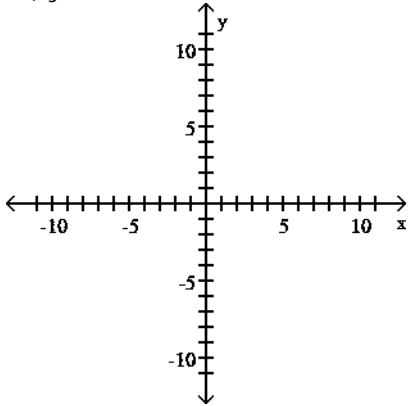

11) _____

A)

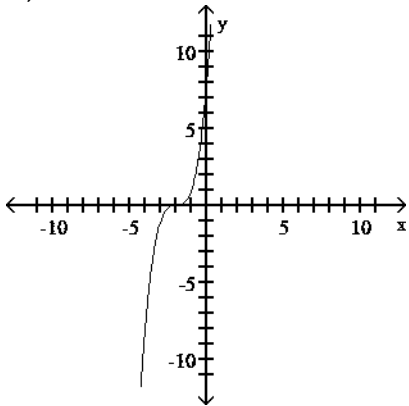

B)

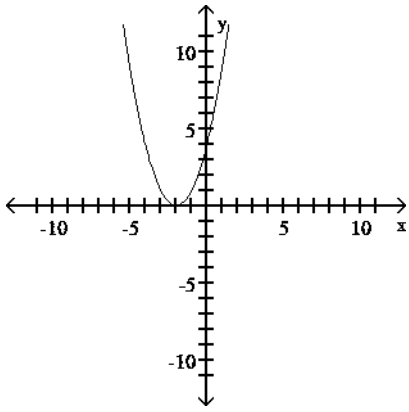

C)

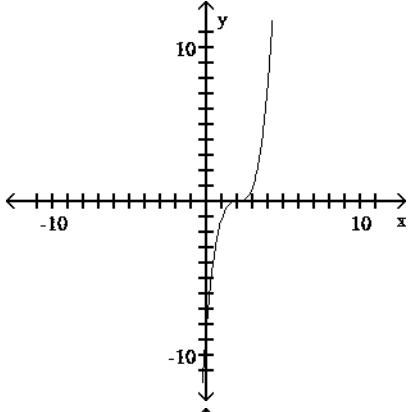

D)

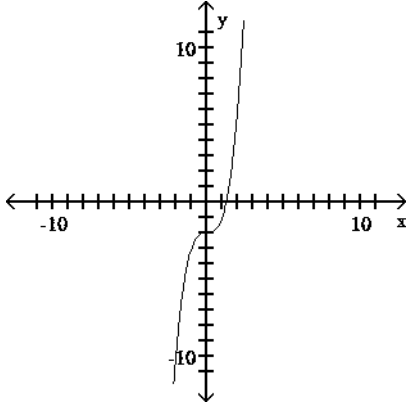

12) $y = \sqrt{x+2} + 1$

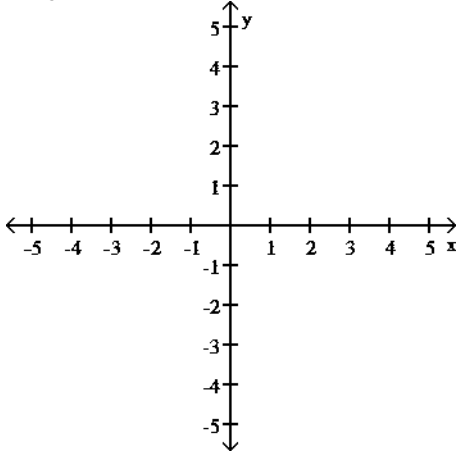

12) _____

A)

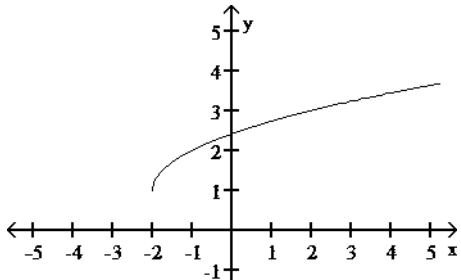

B)

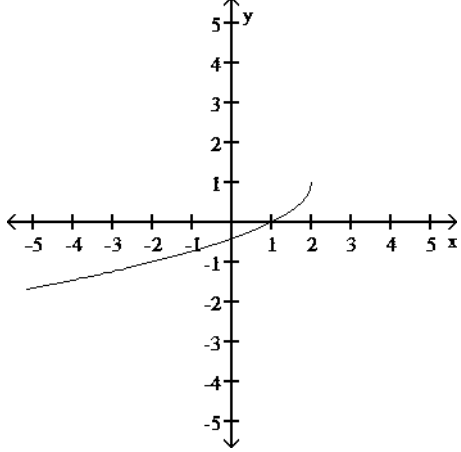

C)

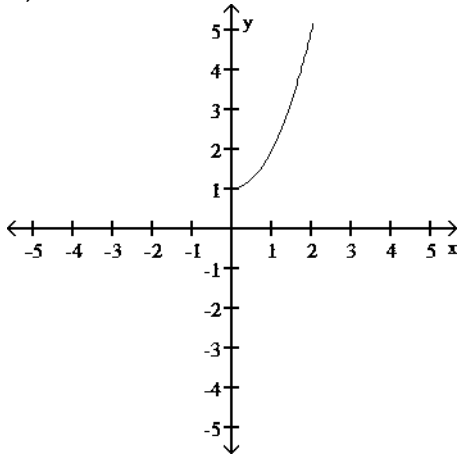

D)

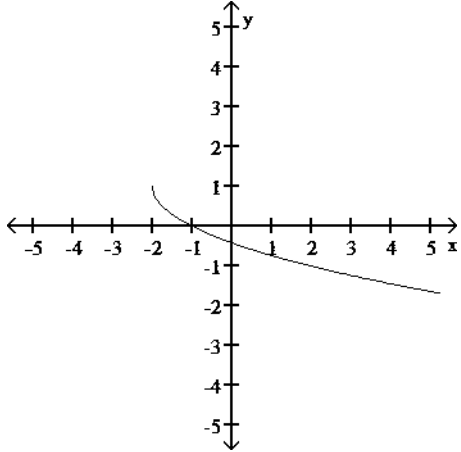

13) $y = |x - 3| - 6$

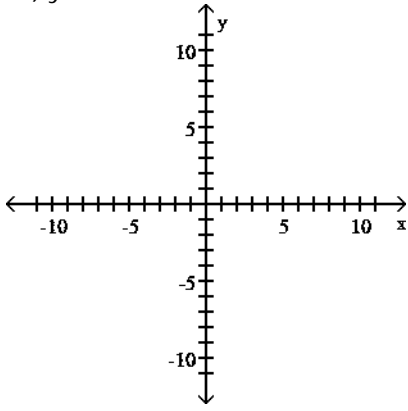

13) _____

A)

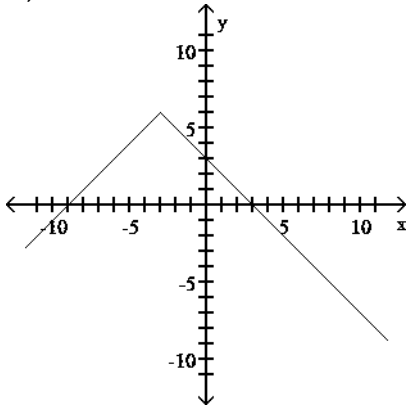

B)

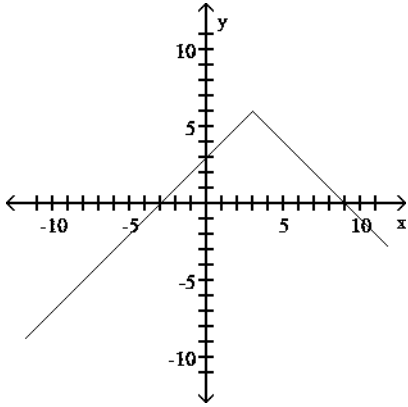

C)

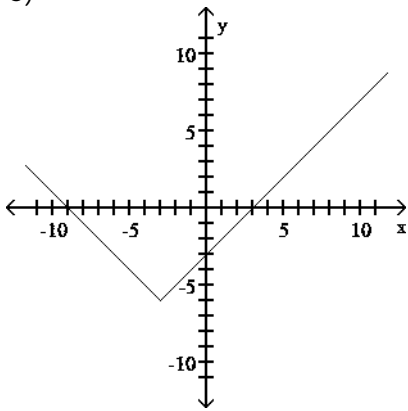

D)

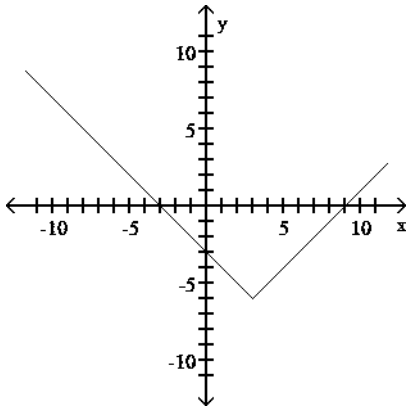

14) $y = (x-2)^2 - 6$

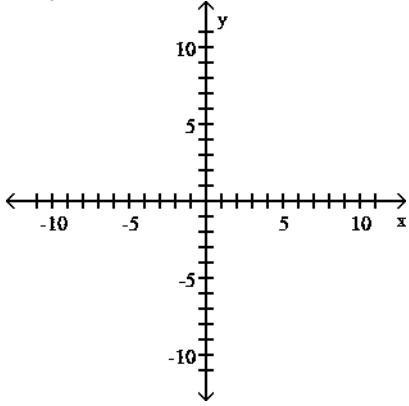

14) _____

A)

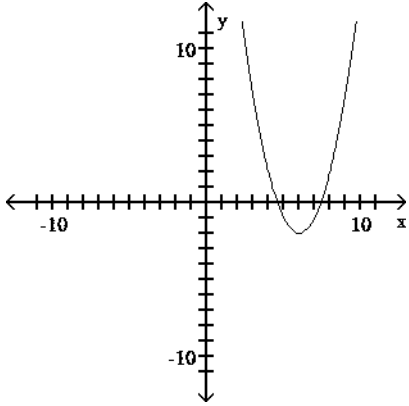

B)

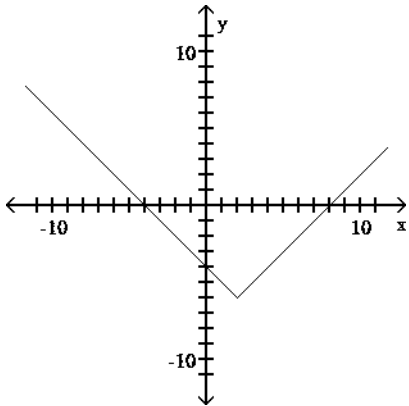

C)

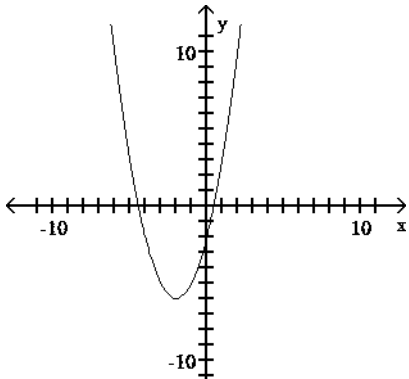

D)

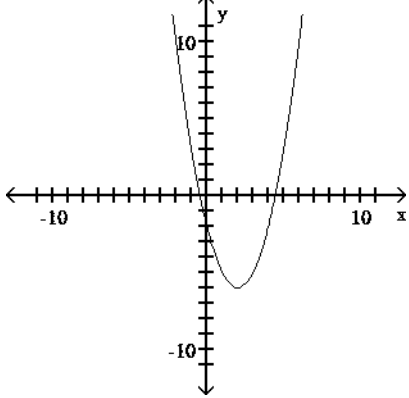

The function Y_2 is defined as $Y_1 + k$ for some real number k . Based upon the given information about Y_1 and Y_2 , find k .

15)

X	Y_1	Y_2
0	-1	3
1	0	4
2	3	7
3	8	12
4	15	19
5	24	28
6	35	39
$X=0$		

15) _____

A) 4 B) 1 C) 2 D) 5

16)

X	Y_1	Y_2
0	-3	-8
1	-2	-7
2	5	0
3	24	19
4	61	56
5	122	117
6	213	208
$X=0$		

16) _____

A) 4 B) -5 C) 5 D) -4

17)

X	Y ₁	Y ₂
0	-2	8
1	-1	9
2	6	16
3	25	35
4	62	72
5	123	133
6	214	224
X=0		

17) _____

A) -10 B) -6 C) 10 D) 6

18)

X	Y ₁	Y ₂
0	-3	-5
1	-2	-4
2	1	-1
3	6	4
4	13	11
5	22	20
6	33	31
X=0		

18) _____

A) 2 B) -1 C) 1 D) -2

19)

X	Y ₁	Y ₂
0	-3	-18
1	-2	-17
2	13	-2
3	78	63
4	253	238
5	622	607
6	1293	1278
X=0		

19) _____

A) 28 B) -25 C) 12 D) -15

20)

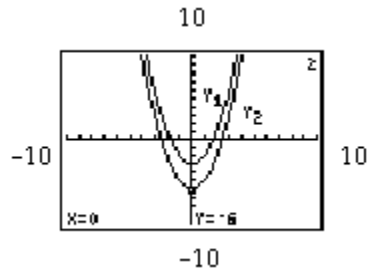
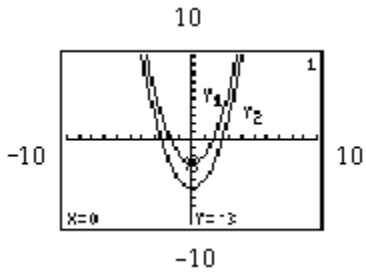

20) _____

- A) 5 B) -2 C) 4 D) -3

21)

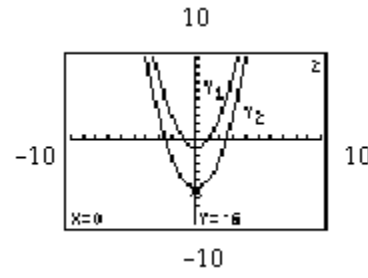
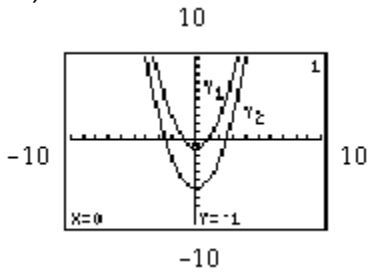

21) _____

- A) 4 B) -5 C) 3 D) -1

22)

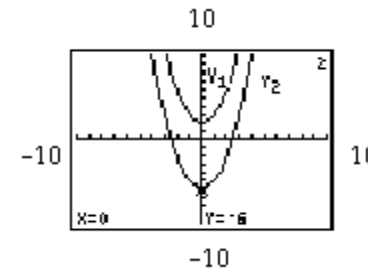
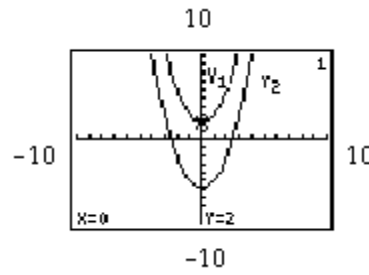

22) _____

- A) -6 B) 7 C) 9 D) -8

23)

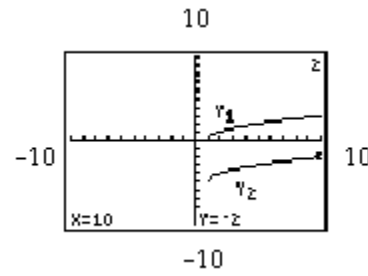
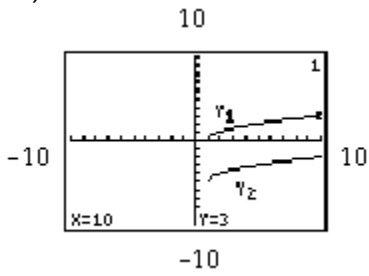

23) _____

- A) 4 B) 3 C) -5 D) -4

24)

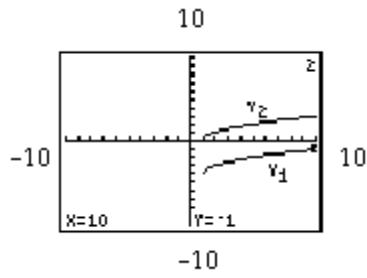
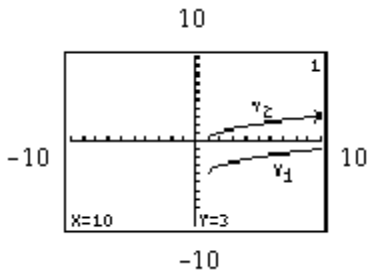

24) _____

- A) 4 B) -5 C) -4 D) 5

Determine the domain and range of the function from the graph.

25)

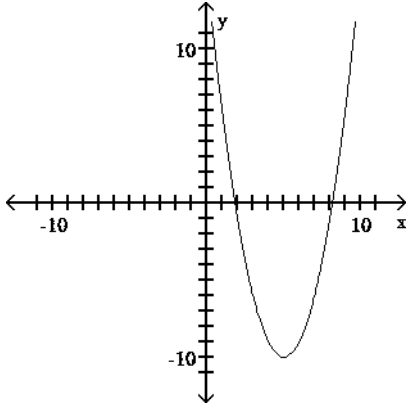

25) _____

- A) $(-\infty, \infty); [-10, \infty)$ B) $(-\infty, 0) \cup (0, \infty); (-\infty, 0) \cup (0, \infty)$
 C) $(-\infty, 0); (-\infty, 0)$ D) $(0, \infty); [35, \infty)$

26)

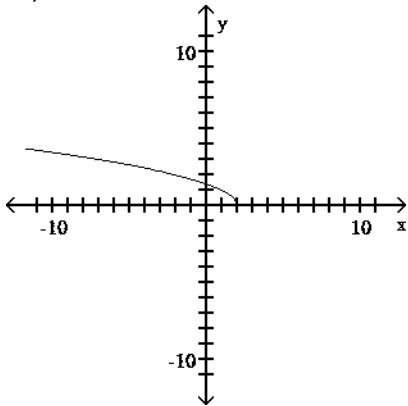

26) _____

- A) $(-\infty, 2) \cup (2, \infty); (-\infty, 0) \cup (0, \infty)$ B) $(-\infty, 2]; [0, \infty)$
 C) $(-\infty, \infty); [0, \infty)$ D) $(\sqrt{2}, \infty); (-\infty, 0]$

27)

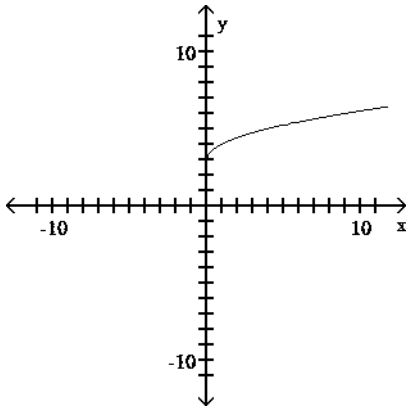

27) _____

- A) $[0, \infty); [3, \infty)$ B) $[-3, \infty); (-\infty, 0]$ C) $[0, \infty); [0, \infty)$ D) $[3, \infty); [0, \infty)$

28)

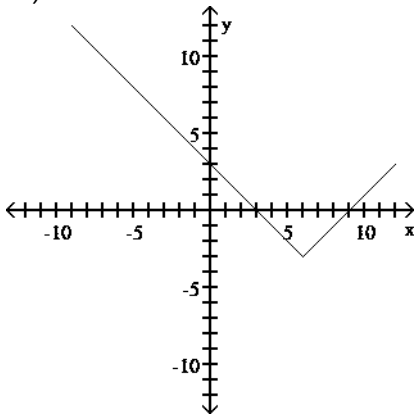

28) _____

- A) $(-\infty, \infty); [-3, \infty)$ B) $(-\infty, \infty); (-\infty, \infty)$ C) $[-3, \infty); (-\infty, \infty)$ D) $(-\infty, \infty); [0, \infty)$

29)

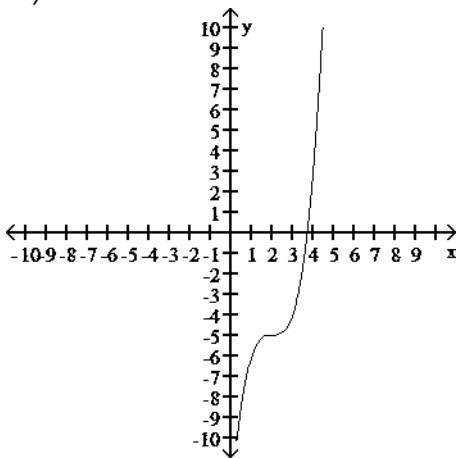

29) _____

- A) $(-\infty, \infty); (-\infty, \infty)$ B) $[0, \infty); [0, \infty)$ C) $(-\infty, \infty); [-5, \infty)$ D) $[2, \infty); (-\infty, \infty)$

Use translations of one of the basic functions defined by $y = x^2$, $y = x^3$, $y = \sqrt{x}$, or $y = |x|$ to sketch a graph of $y = f(x)$ by hand. Do not use a calculator.

30) $y = x^2 - 2$

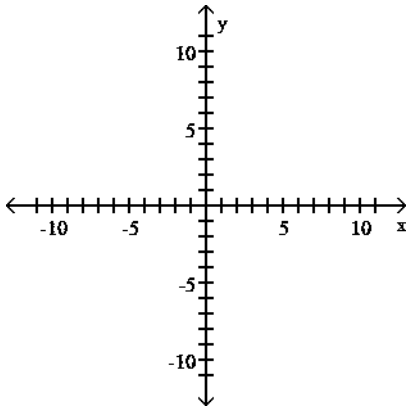

30) _____

A)

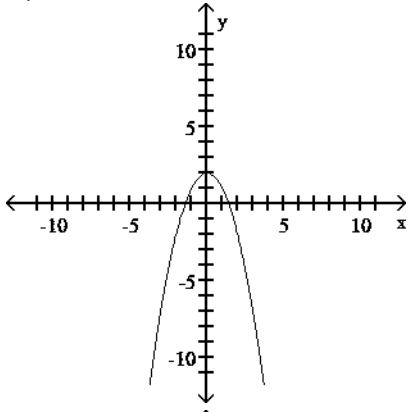

B)

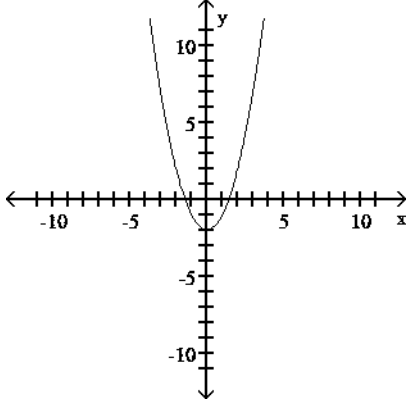

C)

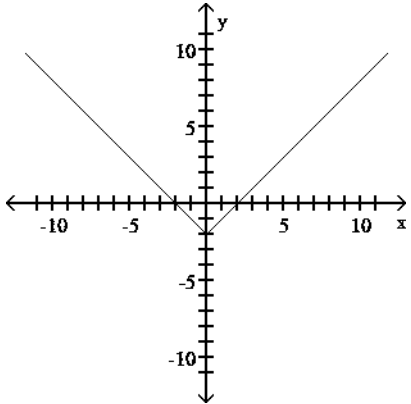

D)

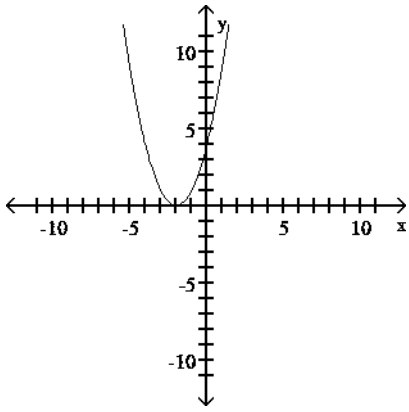

31) $y = |x - 6|$

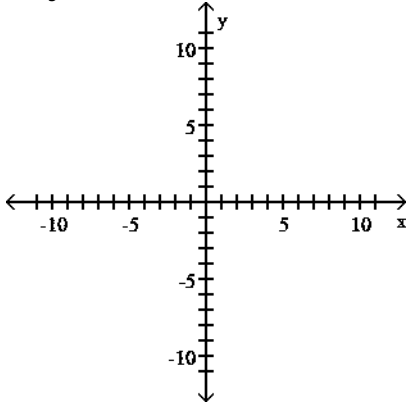

31) _____

A)

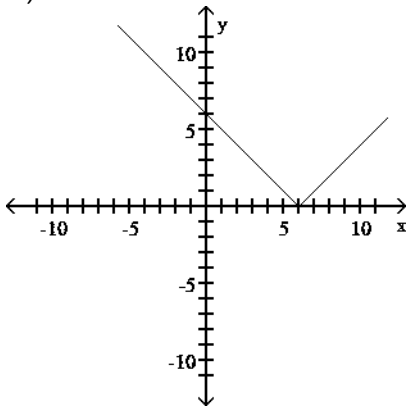

B)

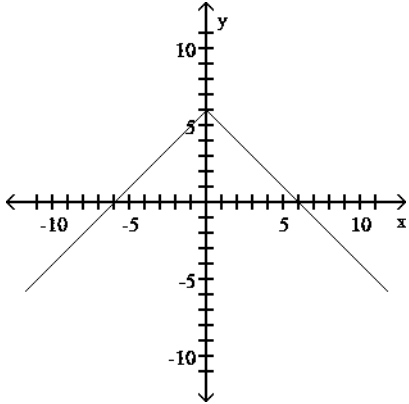

C)

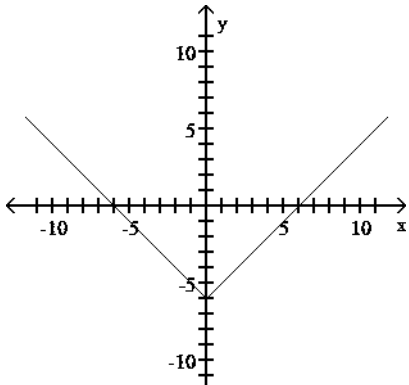

D)

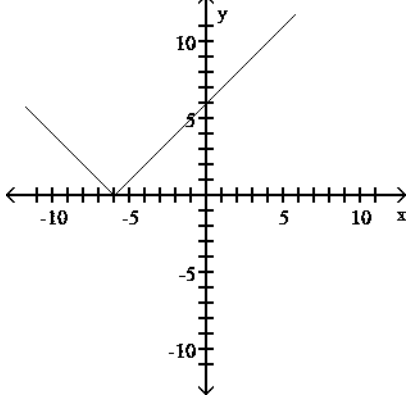

32) $y = (x + 4)^3$

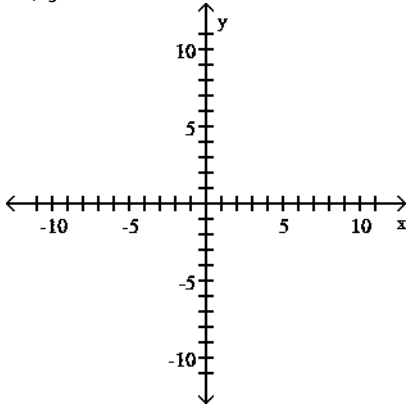

32) _____

A)

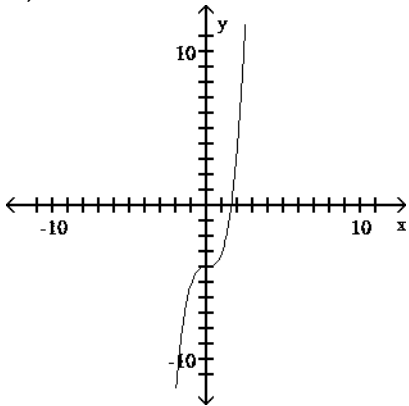

B)

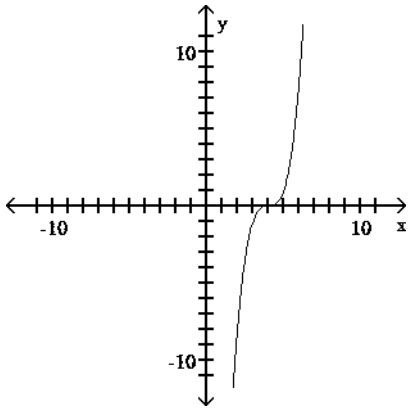

C)

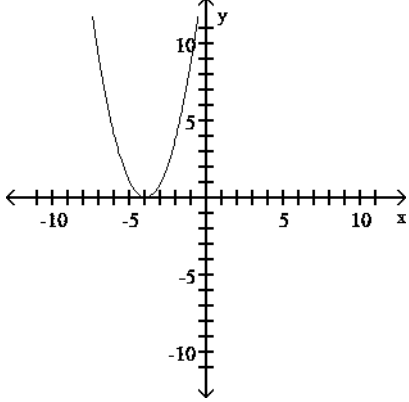
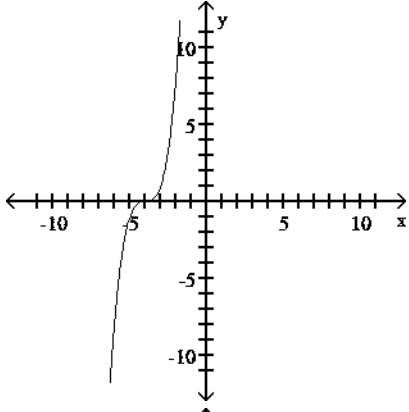

D)

33) $y = x^3 + 4$

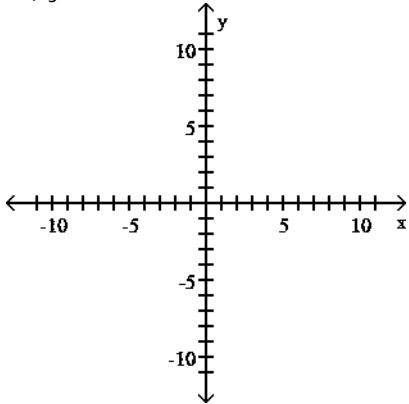

33) _____

A)

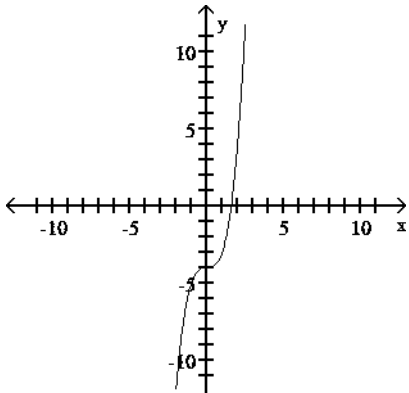

B)

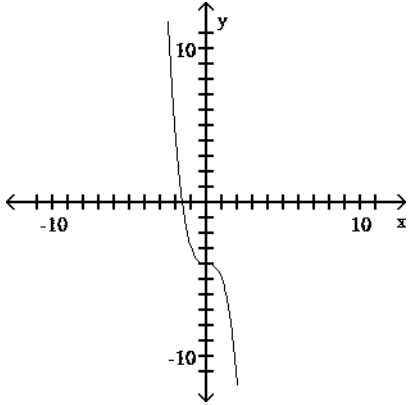

C)

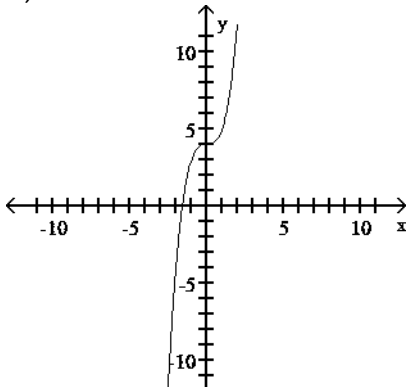

D)

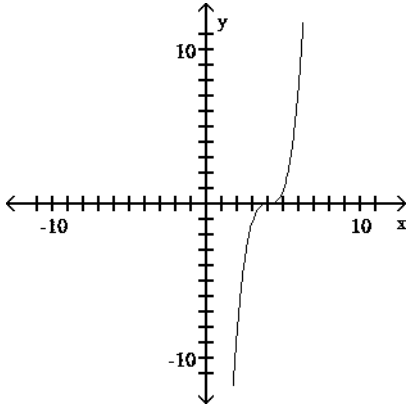

34) $y = \sqrt{x+3}$

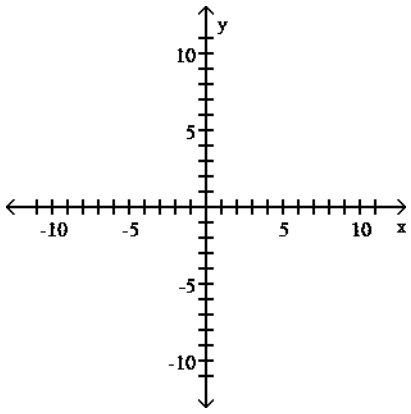

34) _____

A)

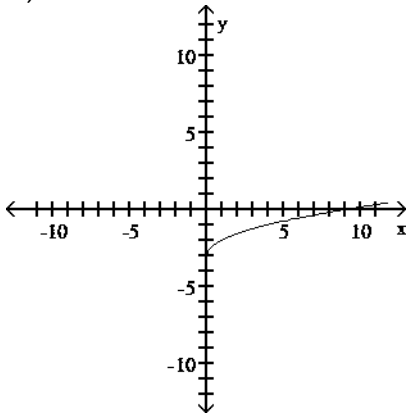

B)

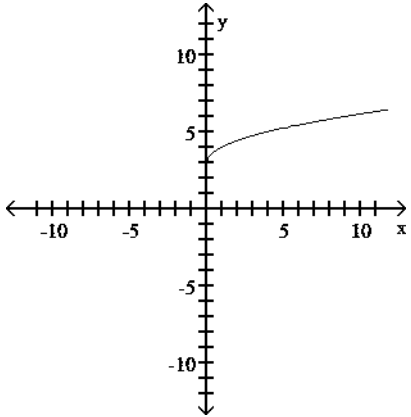

C)

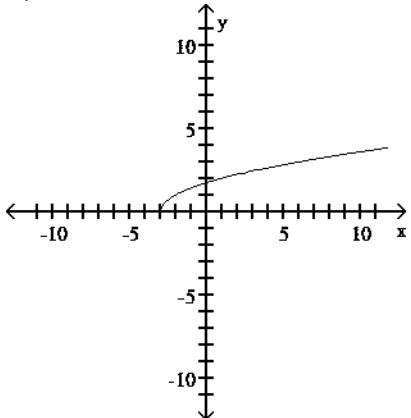

D)

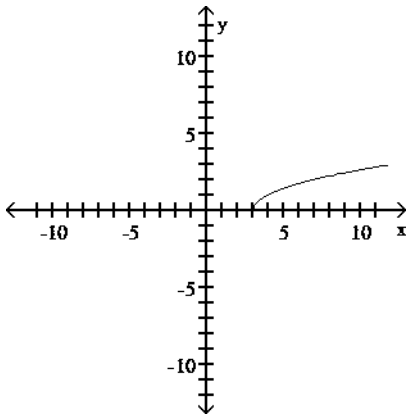

35) $y = -3 + |x|$

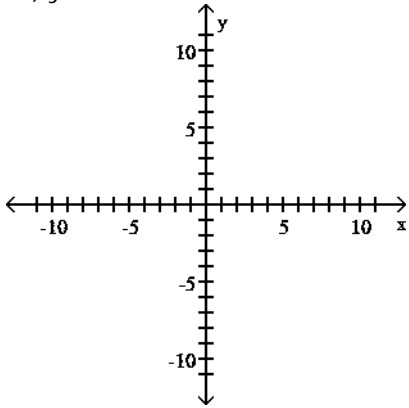

35) _____

A)

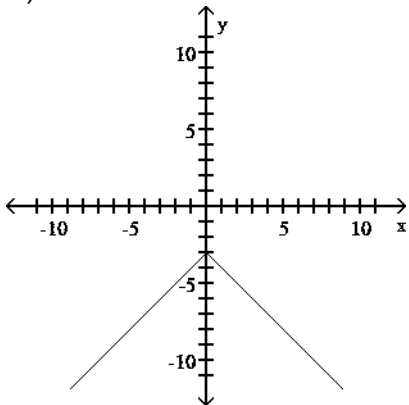

B)

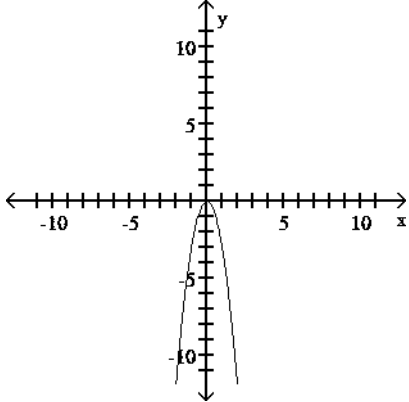

C)

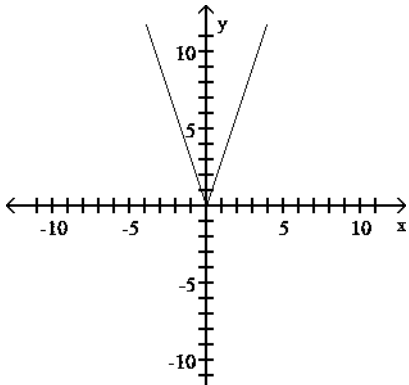

D)

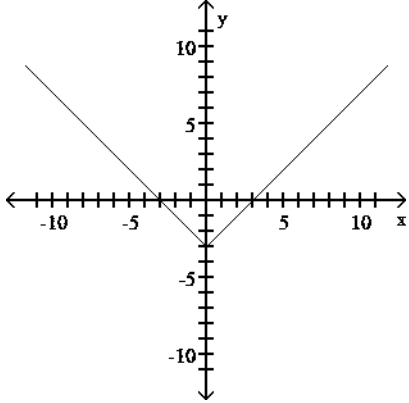

36) $y = (x - 6)^2 - 3$

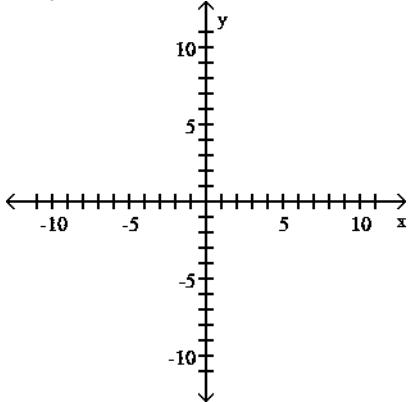

36) _____

A)

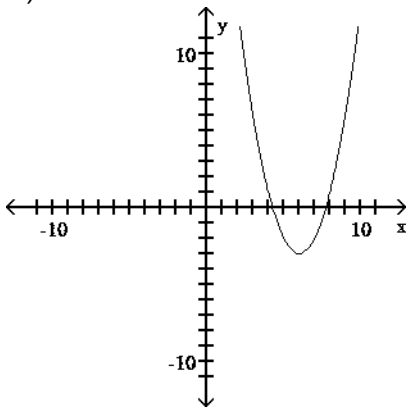

B)

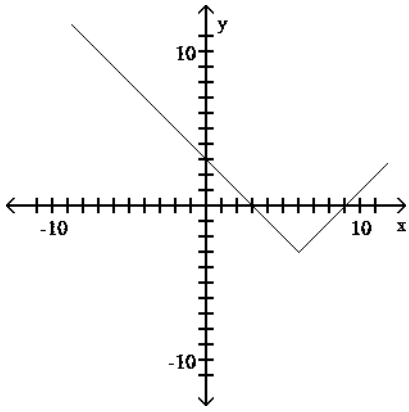

C)

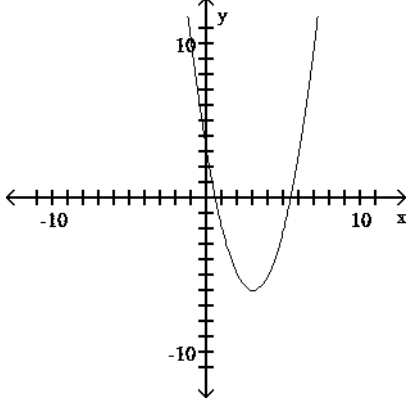
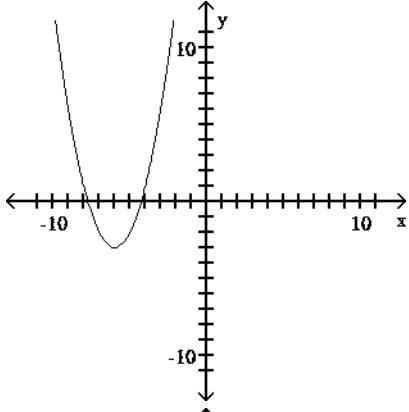

D)

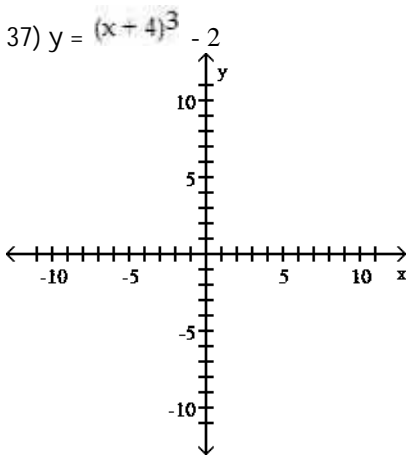

37) _____

A)

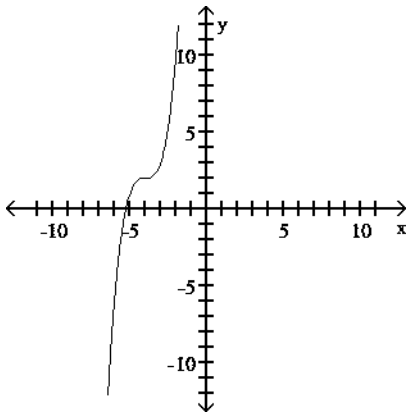

B)

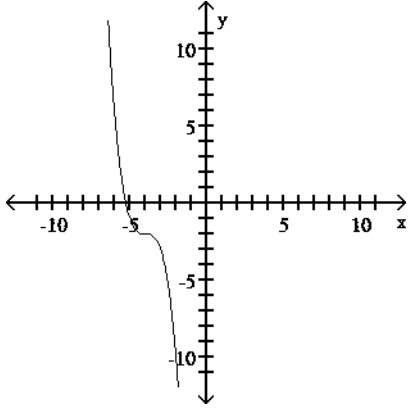

C)

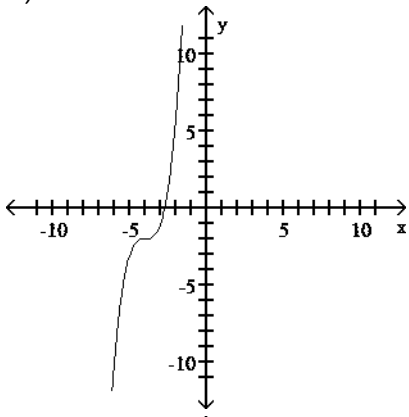

D)

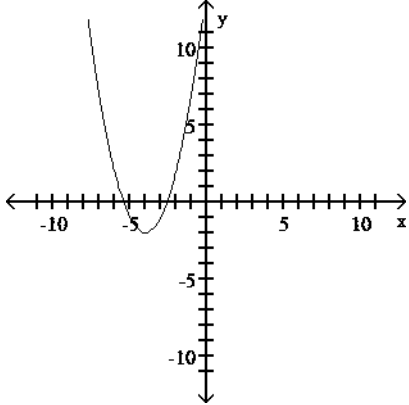

38) $y = (x-2)^2 + 2$

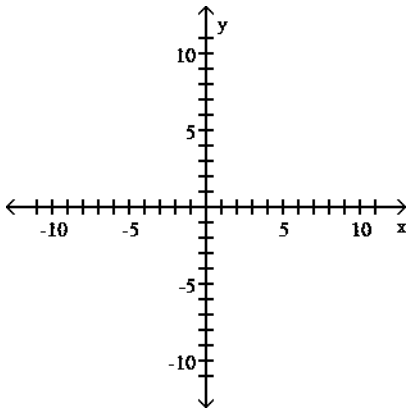

38) _____

A)

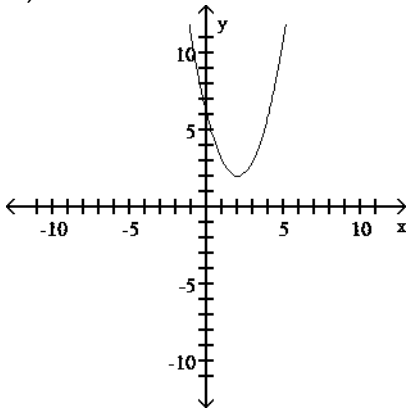

B)

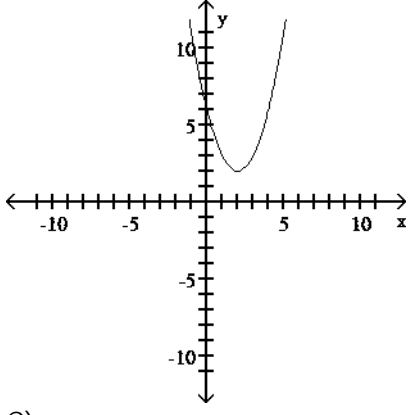

C)

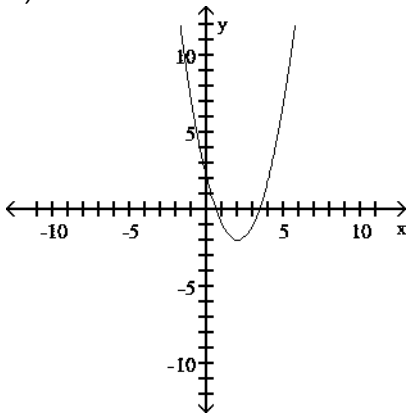

D)

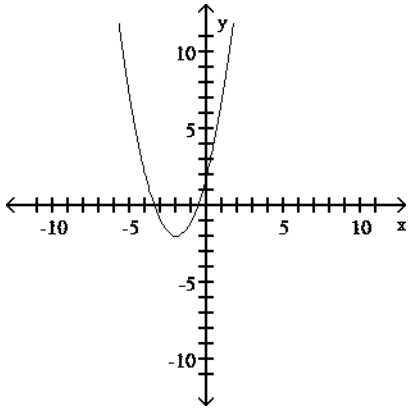

39) $y = |x + 6| + 5$

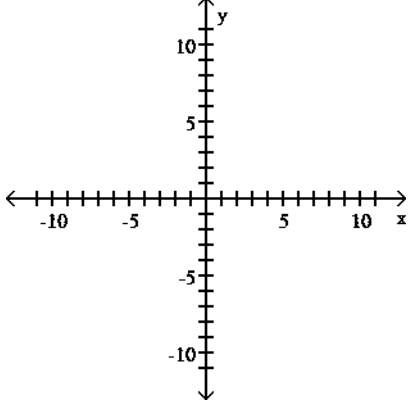

39) _____

A)

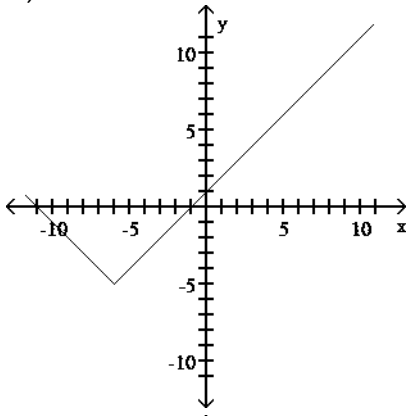

B)

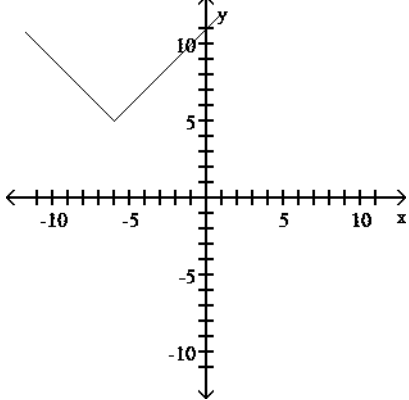

C)

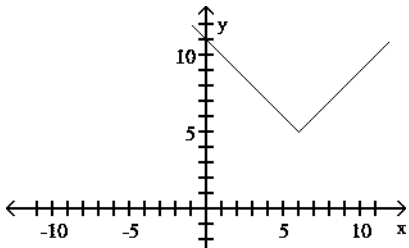

D)

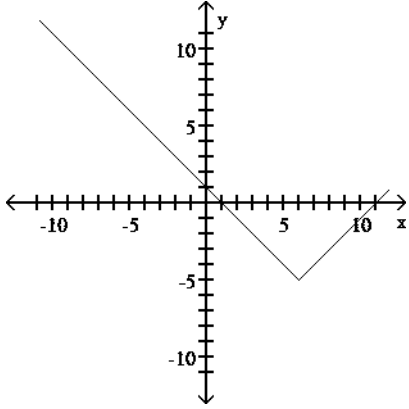

40) $y = \sqrt{x+5} - 5$

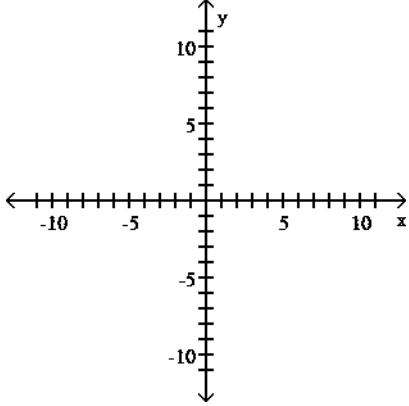

40) _____

A)

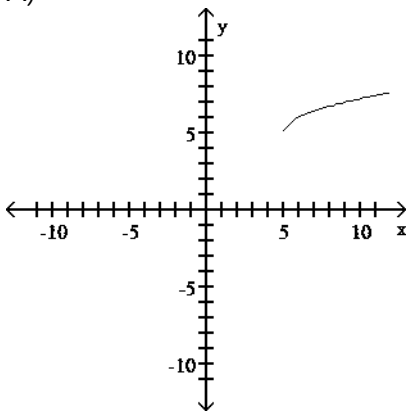

B)

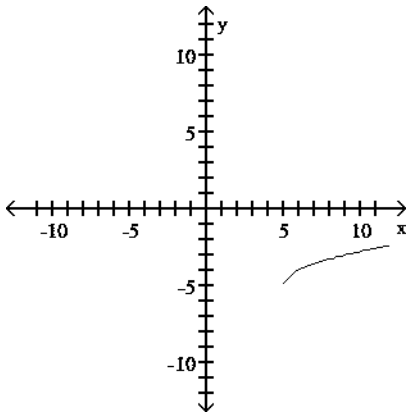

C)

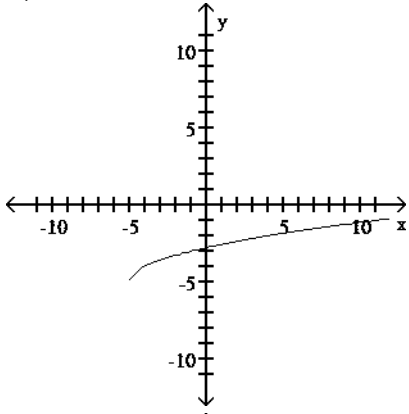

D)

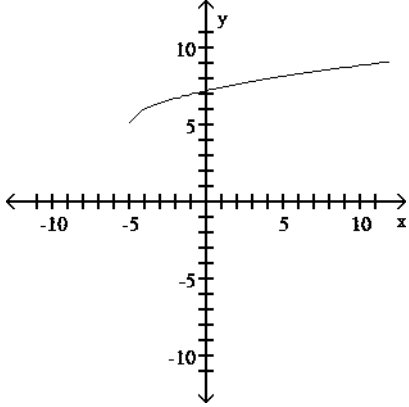

The graph is a translation of one of the basic functions defined by $y = x^2$, $y = x^3$, $y = \sqrt{x}$, or $y = |x|$. Find the equation that defines the function.

41)

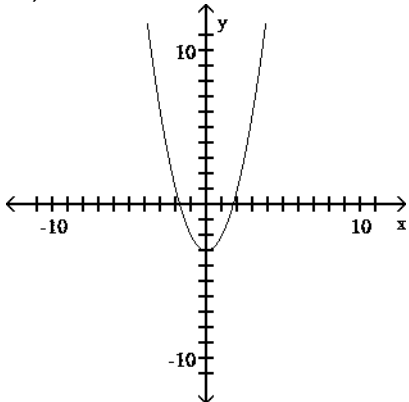

41) _____

- A) $y = x^2 - 3$ B) $y = (x-3)^2$ C) $y = (x-3)^2 + 3$ D) $y = (x+3)^2$

42)

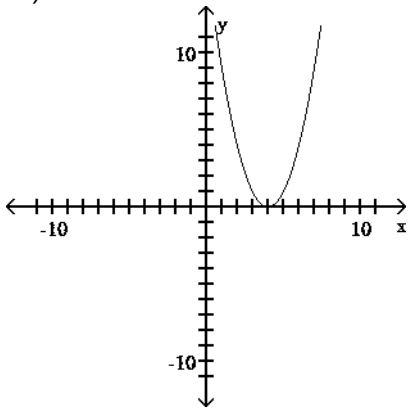

42) _____

- A) $y = (x-4)^2 + 1$ B) $y = (x+4)^2$ C) $y = x^2 - 4$ D) $y = (x-4)^2$

43)

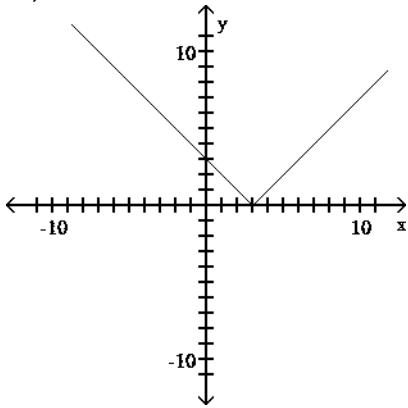

43) _____

- A) $y = |x-3|$ B) $y = |x+3|$ C) $y = |x| - 3$ D) $y = |x-3| + 3$

44)

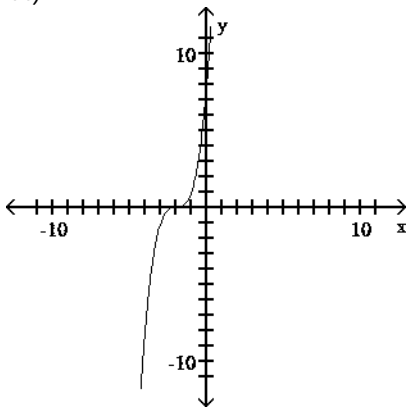

44) _____

- A) $y = x^3 + 2$ B) $y = (x+2)^3 + 3$ C) $y = (x+2)^3$ D) $y = (x-2)^3$

45)

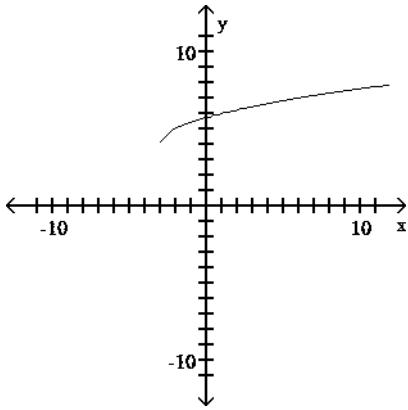

45) _____

- A) $y = \sqrt{x+3} + 4$ B) $y = \sqrt{x} + 4$ C) $y = \sqrt{x+3}$ D) $y = \sqrt{x-3}$

46)

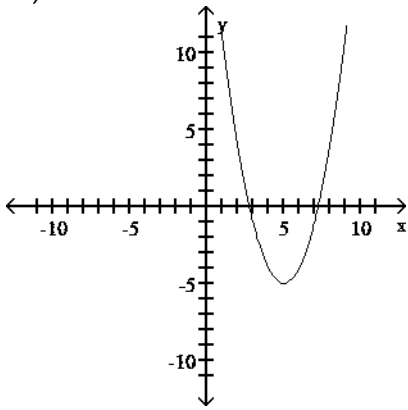

46) _____

- A) $y = 3(x+5)^2$ B) $y = (x-3)^2 - 5$ C) $y = (x-5)^2 - 5$ D) $y = -3(x-5)^2$

Find the linear equation that meets the stated criteria.

47) The linear equation $y = 233x + 6320$ provides an approximation of the annual cost (in dollars) to rent an apartment at the Leisure Village Retirement Community, where $x = 1$ represents 1986, $x = 2$ represents 1987, and so on. Write an equation that yields the same y -values when the exact year number is entered. 47) _____

- A) $y = 233(x - 1986) + 6320$ B) $y = 233(1986 - x) + 6320$
 C) $y = 233(x - 1985) + 6320$ D) $y = 233(1985 - x) + 6320$

48) The linear equation $y = 479x + 3420$ provides an approximation of the annual cost (in dollars) of health insurance for a family of three, where $x = 1$ represents 1993, $x = 2$ represents 1994, and so on. Write an equation that yields the same y -values when the exact year number is entered. 48) _____

- A) $y = 479(1992 - x) + 3420$ B) $y = 479(x - 1992) + 3420$
 C) $y = 479(1993 - x) + 3420$ D) $y = 479(x - 1993) + 3420$

49) The linear equation $y = 81.83x + 1169$ provides an approximation of the value (in dollars) of an account opened on January 1, 1990, in the amount of \$1169 and earning 7% simple interest, where $x = 0$ represents January 1, 1990, $x = 1$ represents January 1, 1991, $x = 2$ represents January 1, 1992, and so on. Write an equation that yields the same y -values when the exact year number is entered. 49) _____

- A) $y = 81.83(1991 - x) + 1169$ B) $y = 81.83(1990 - x) + 1169$
 C) $y = 81.83(x - 1991) + 1169$ D) $y = 81.83(x - 1990) + 1169$

50) The table shows the number of members in the Windy City Edsel Owners Club during the years 1980-1984.

Year	Number of Members
1980	64
1981	71
1982	75
1983	86
1984	99

Use a calculator to find the least squares regression line for this data, where $x = 0$ represents 1980, $x = 1$ represents 1981, and so on. 50) _____

- A) $y = 8.5x + 62$ B) $y = 8.1x + 59$ C) $y = 8.3x + 61$ D) $y = 7.9x + 63$

51) The table shows the number of members in the Windy City Edsel Owners Club during the years 1986-1990.

Year	Number of Members
1986	111
1987	132
1988	167
1989	197
1990	219

Use a calculator to find the least squares regression line for this data, where $x = 0$ represents 1986, $x = 1$ represents 1987, and so on. 51) _____

- A) $y = 28.3x + 106$ B) $y = 27.6x + 111$ C) $y = 28.1x + 109$ D) $y = 28.4x + 105$

Provide an appropriate response.

52) Explain how the graph of $g(x) = f(x) - 4$ is obtained from the graph of $y = f(x)$. 52) _____

- A) Shift the graph of f to the left 4 units. B) Shift the graph of f downward 4 units.
C) Shift the graph of f to the right 4 units. D) Shift the graph of f upward 4 units.

53) Explain how the graph of $g(x) = f(x - 4)$ is obtained from the graph of $y = f(x)$. 53) _____

- A) Shift the graph of f to the left 4 units. B) Shift the graph of f to the right 4 units.
C) Shift the graph of f downward 4 units. D) Shift the graph of f upward 4 units.

54) Which function represents a vertical translation of the parabola $y = (x - 2)^2 + 1$? 54) _____

- A) $y = x^2 + 1$ B) $y = -(x - 2)^2 + 1$ C) $y = (x + 2)^2 + 1$ D) $y = (x - 2)^2 + 3$

55) The graph shown is a translation of the function $y = |x|$. The graph shown is of the form $y = |x - h| + k$. What are the values of h and k ?

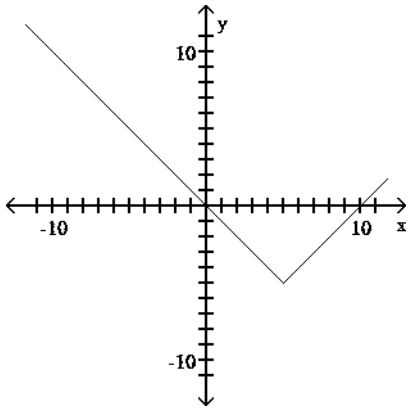

55) _____

- A) $h = 5, k = 5$ B) $h = 5, k = -5$ C) $h = -5, k = 5$ D) $h = -5, k = -5$

56) Sketch the graph of $y = f(x - 3)$ for the given graph of $y = f(x)$.

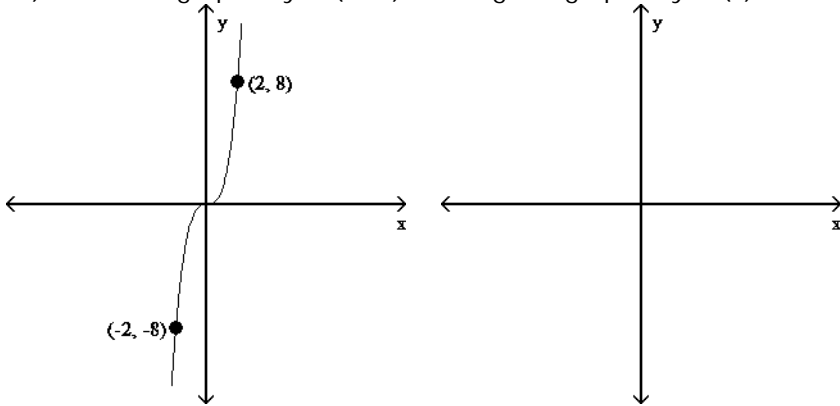

56) _____

A)

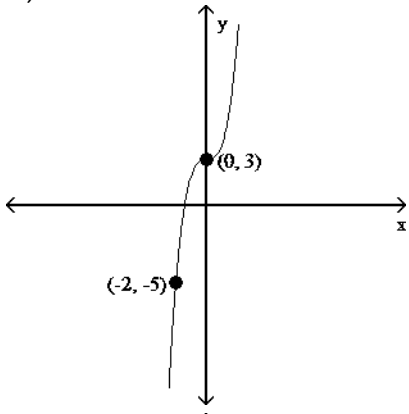

B)

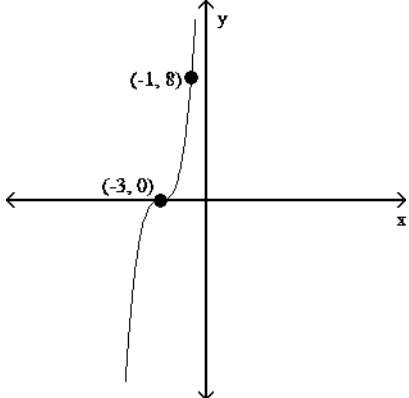

C)

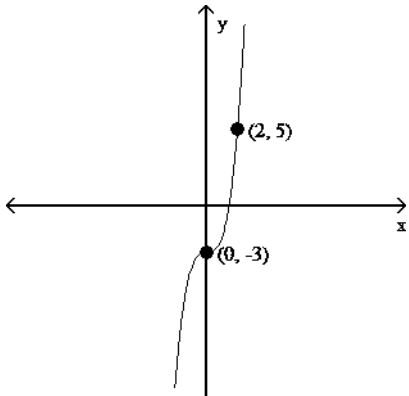

D)

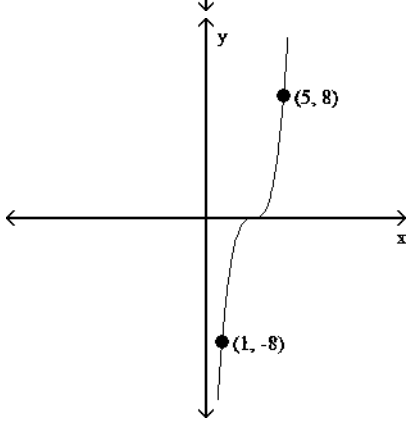

57) Sketch the graph of $y = f(x + 5)$ for the given graph of $y = f(x)$.

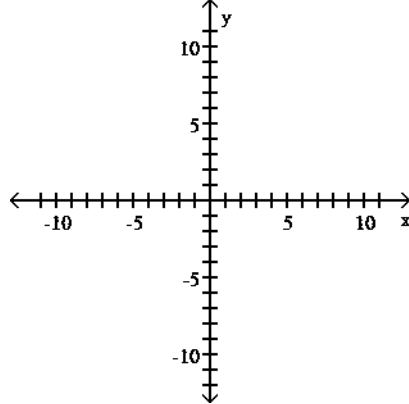
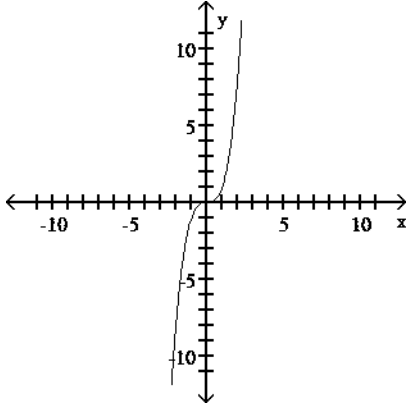

57) _____

A)

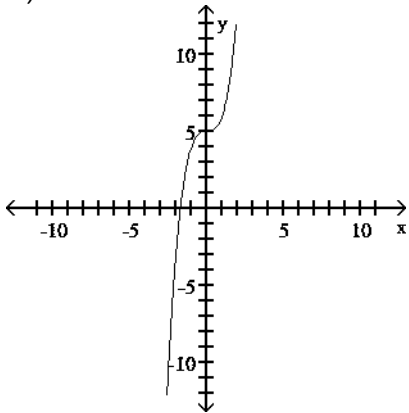

B)

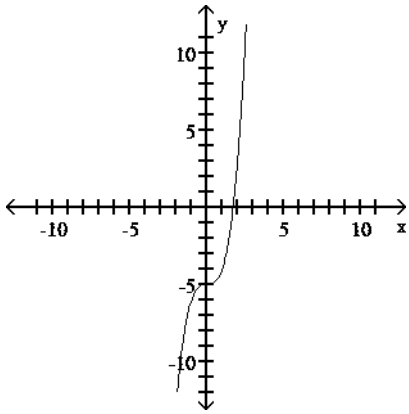

C)

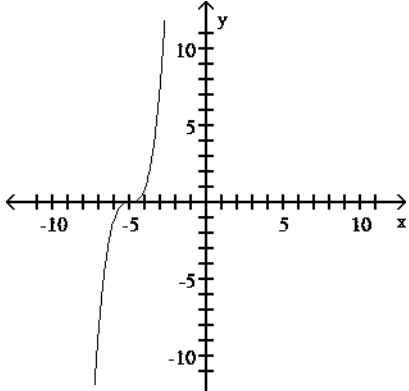

D)

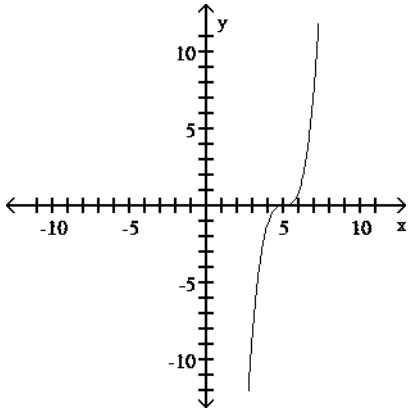

58) Use the graph of $y = f(x)$ to find the x-intercepts of the graph of $y = f(x + 2)$.

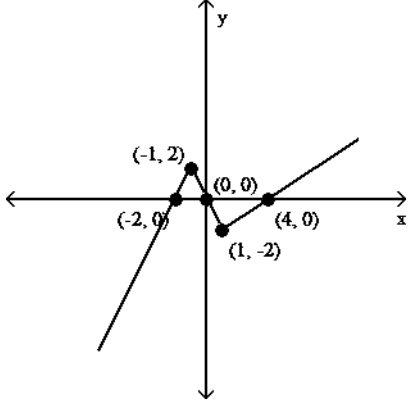

58) _____

A) -4, -2, 2

B) -3, 0 C) 0, 2, 6

D) -2, 0, 4

- 1) B
- 2) A
- 3) A
- 4) C
- 5) C
- 6) B
- 7) D
- 8) D
- 9) D
- 10) D
- 11) A
- 12) A
- 13) D
- 14) D
- 15) A
- 16) B
- 17) C
- 18) D
- 19) D
- 20) D
- 21) B
- 22) D
- 23) C
- 24) A
- 25) A
- 26) B
- 27) A
- 28) A
- 29) A
- 30) B
- 31) A
- 32) C
- 33) C
- 34) C
- 35) D
- 36) A
- 37) C
- 38) A
- 39) B
- 40) C
- 41) A
- 42) D
- 43) A
- 44) C
- 45) A
- 46) C
- 47) C
- 48) B
- 49) D
- 50) A
- 51) C

- 52) B
- 53) B
- 54) D
- 55) B
- 56) D
- 57) C
- 58) A

Exam

Name _____

MULTIPLE CHOICE. Choose the one alternative that best completes the statement or answers the question.

Write the equation that results in the desired transformation.

1) The square root function, reflected across the x-axis 1) _____

- A) $y = \sqrt{x}$ B) $y = -\sqrt{x}$ C) $y = -\sqrt{x}$ D) $y = \sqrt{x} - 1$

2) The squaring function, vertically stretched by a factor of 2 2) _____

- A) $y = 2x^2$ B) $y = (x-2)^2$ C) $y = -2x^2$ D) $y = 2(x-2)x^2$

3) The cubing function, vertically shrunk by a factor of 0.4 3) _____

- A) $y = (x+0.4)^3$ B) $y = (x-0.4)^3$ C) $y = 0.4\sqrt[3]{x}$ D) $y = 0.4x^3$

4) The squaring function, vertically stretched by a factor of 4 and reflected across the x-axis 4) _____

- A) $y = (x-4)^2$ B) $y = 4(x-4)x^2$ C) $y = 4x^2$ D) $y = -4x^2$

5) The absolute value function, vertically stretched by a factor of 8.2 and reflected across the x-axis 5) _____

- A) $y = 8.2|x|$ B) $y = -|x+8.2|$ C) $y = 8.2|-x|$ D) $y = -8.2|x|$

6) The absolute value function, vertically stretched by a factor of 7.6 and reflected across the y-axis 6) _____

- A) $y = |-x+7.6|$ B) $y = -7.6|x|$ C) $y = 7.6|-x|$ D) $y = |-x-7.6|$

Use transformations of graphs to sketch the graphs of y_1 and y_2 . Graph y_2 as a dashed curve.

7) $y_1 = x^2$; $y_2 = x^2 - 5$

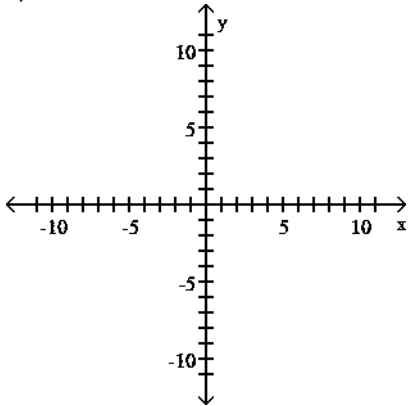

7) _____

A)

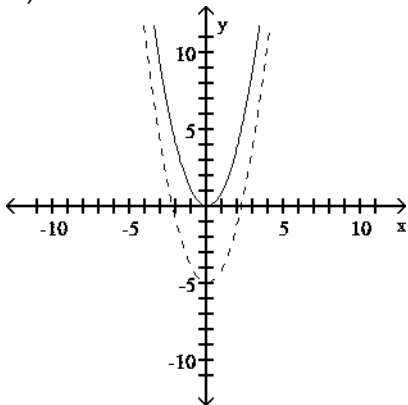

B)

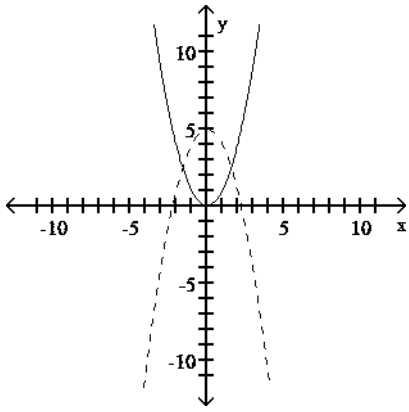

C)

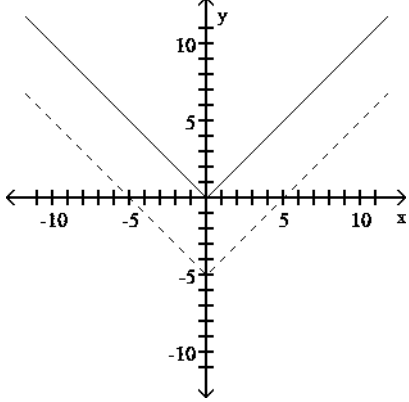
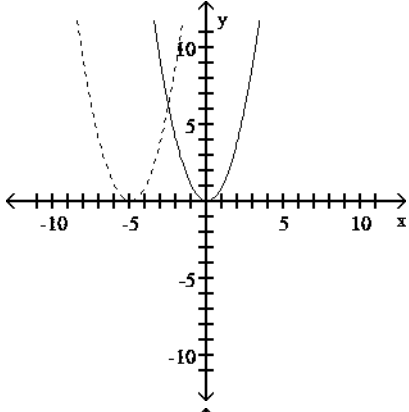

D)

8) $y_1 = |x|$; $y_2 = |x - 6|$

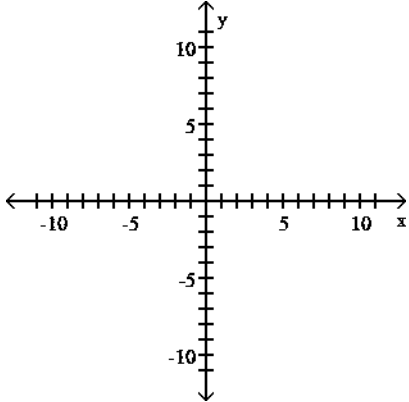

8) _____

A)

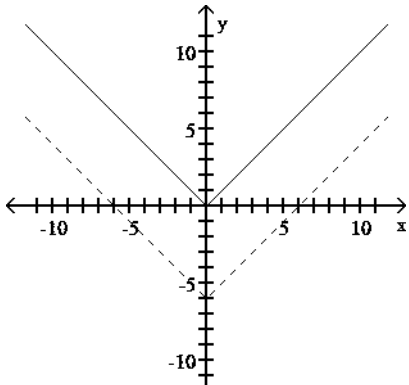

B)

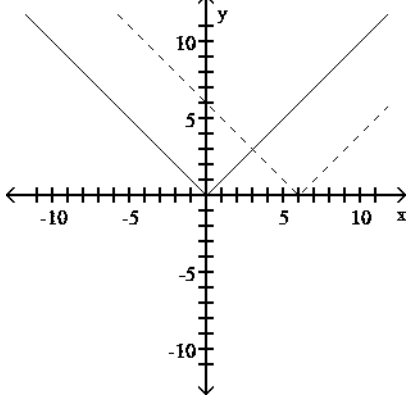

C)

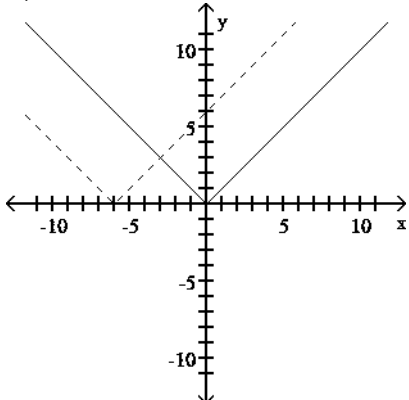

D)

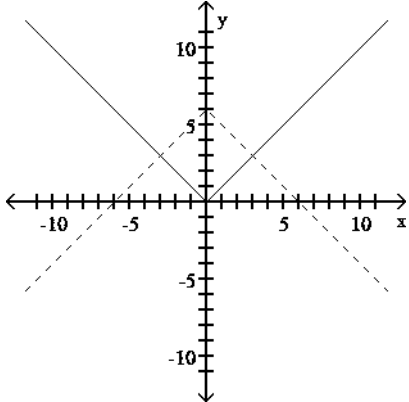

9) $y_1 = x^3$; $y_2 = (x + 2)^3$

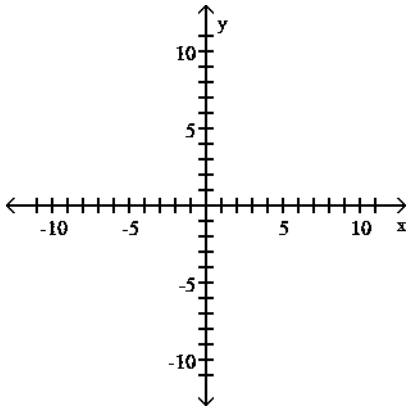

9) _____

A)

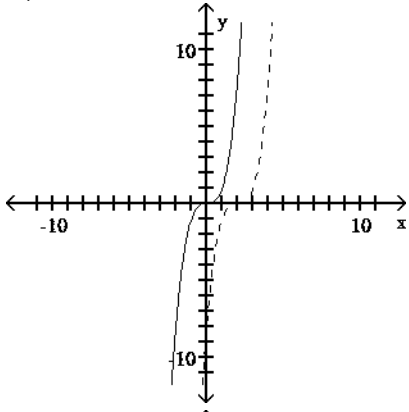

B)

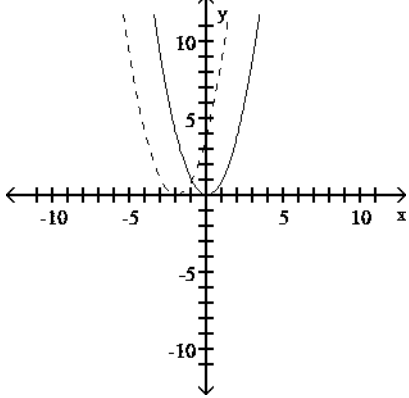

C)

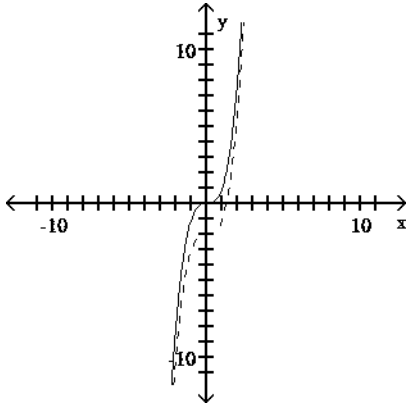

D)

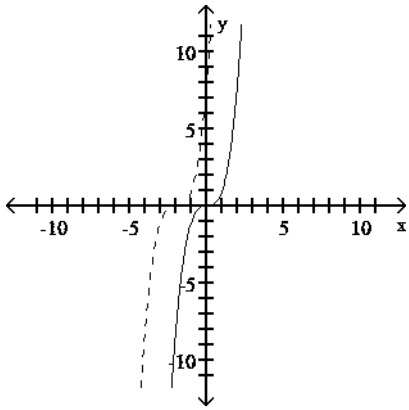

10) $y_1 = |x|$; $y_2 = -3|x|$

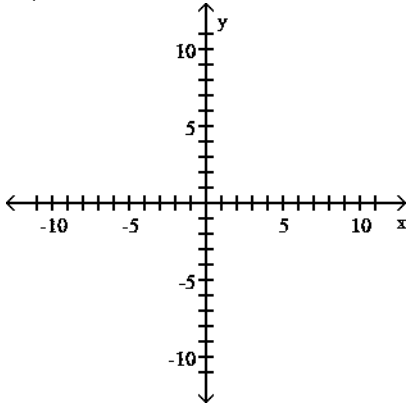

10) _____

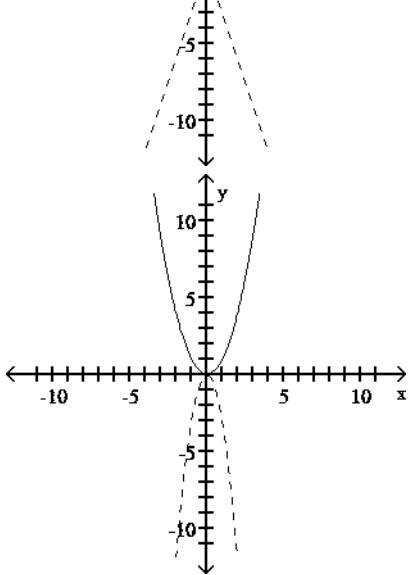
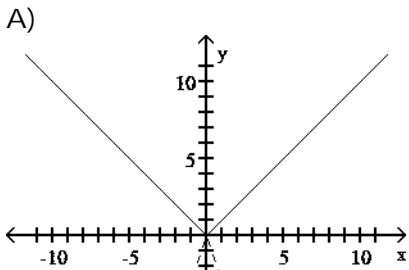

B)

C)

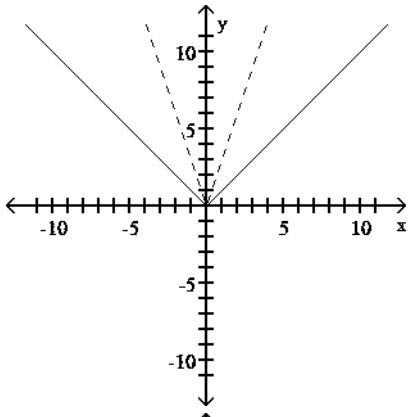

D)

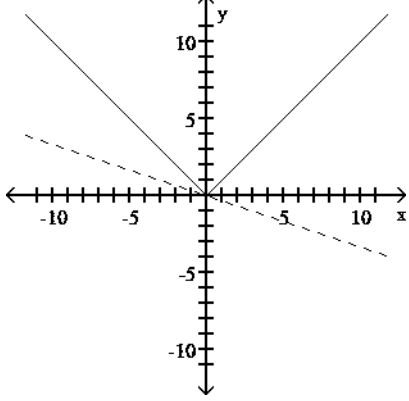

11) $y_1 = x^2$; $y_2 = (x-6)^2 - 2$

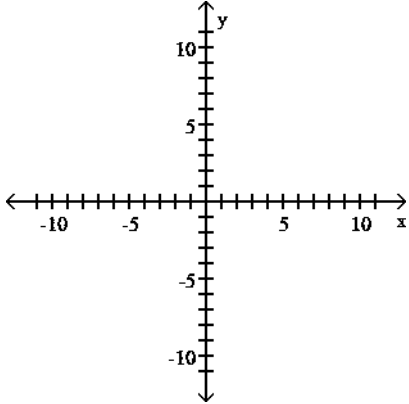

11) _____

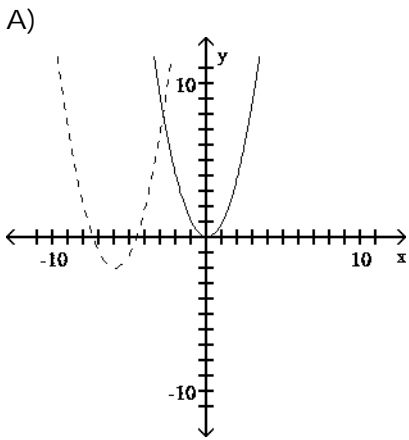

B)

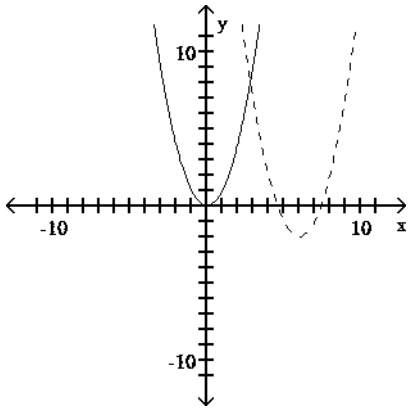

C)

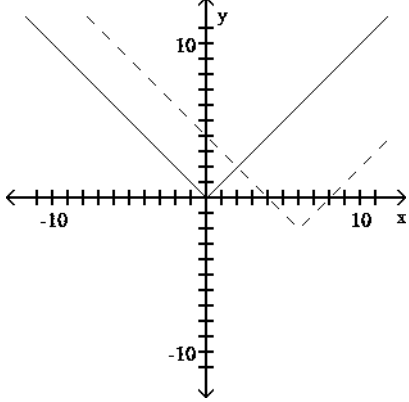
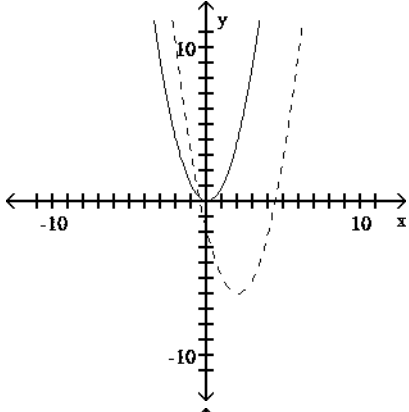

D)

12) $y_1 = x^2$, $y_2 = -4(x+2)^2 + 4$

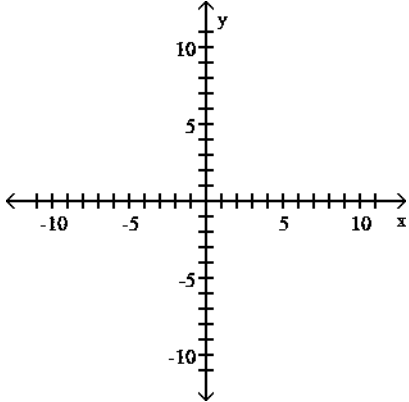

12) _____

A)

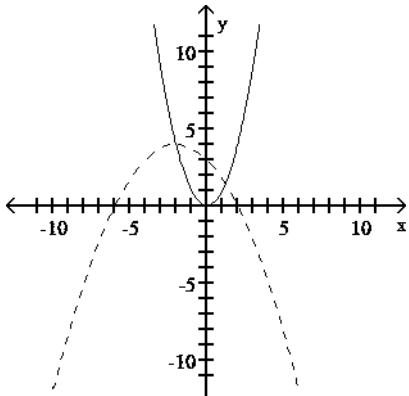

B)

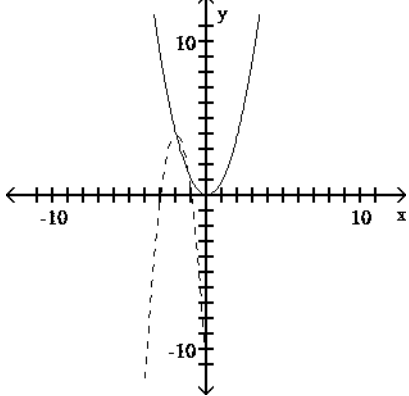

C)

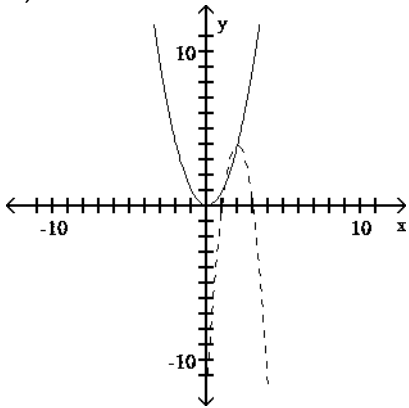

D)

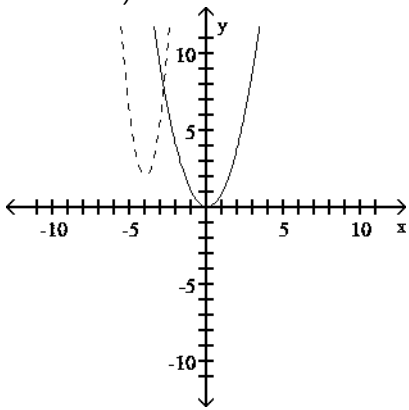

13) $y_1 = \sqrt[3]{x}$, $y_2 = \sqrt[3]{x} + 2$

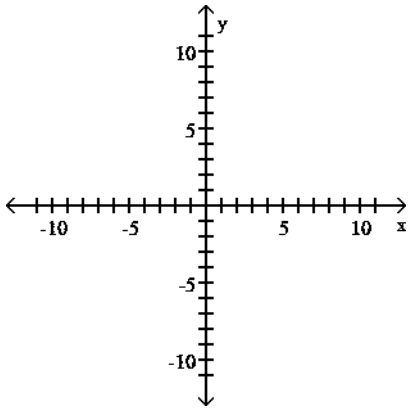

13) _____

A)

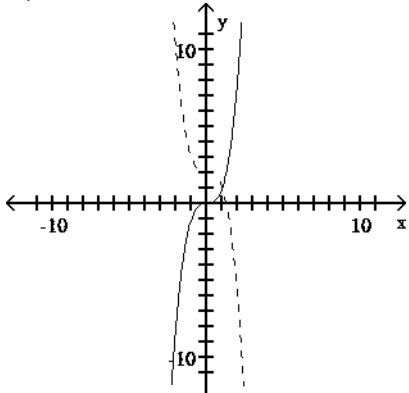

B)

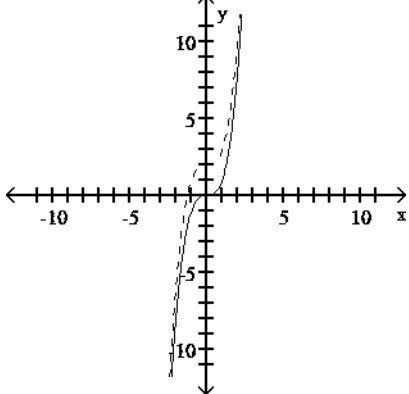

C)

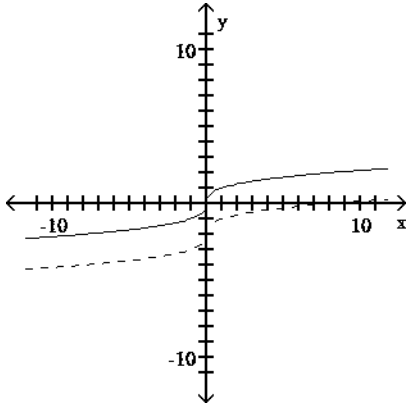

D)

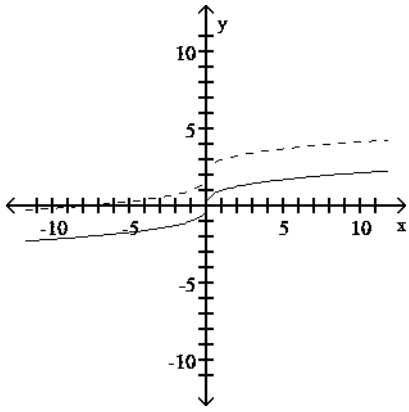

14) $y_1 = |x|$, $y_2 = \frac{1}{2}|x+3| - 2$

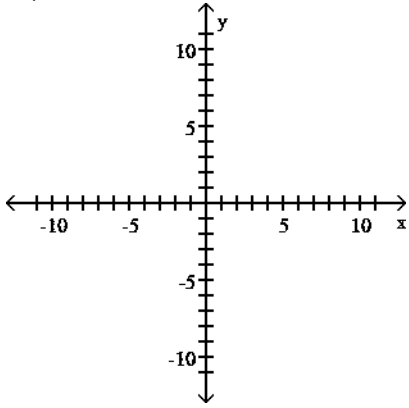

14) _____

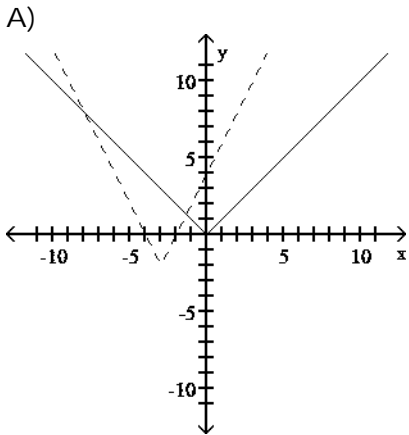

B)

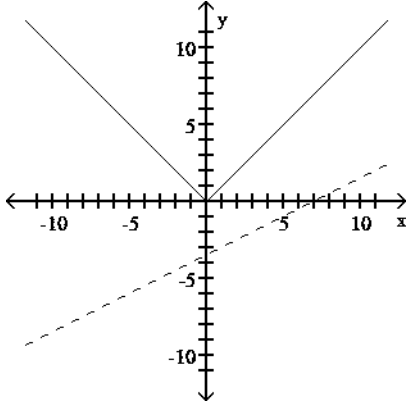

C)

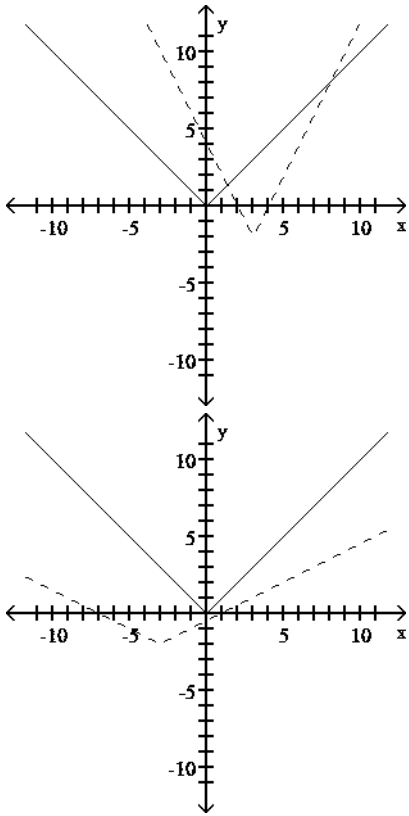

D)

15) $y_1 = \sqrt[3]{x}$, $y_2 = \sqrt[3]{-x} + 5$

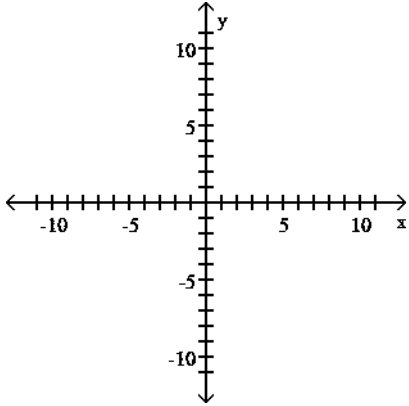

15) _____

A)

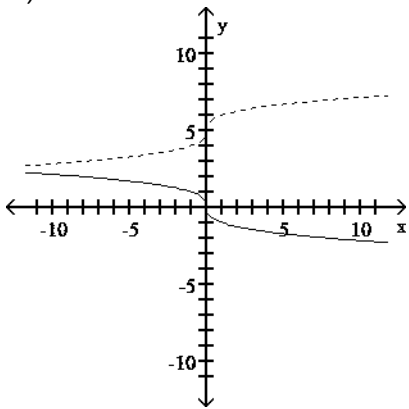

B)

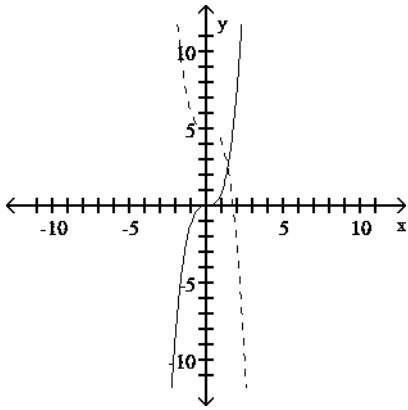

C)

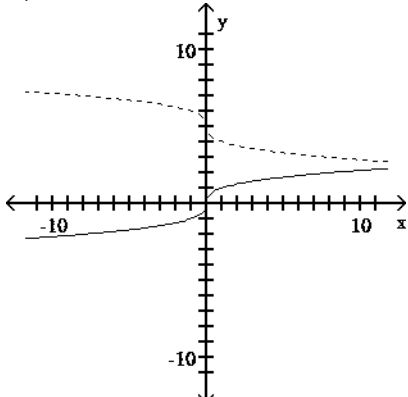

D)

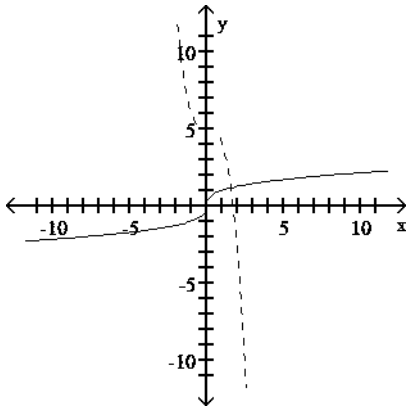

Fill in each blank with the appropriate response.

16) The graph of $y = -6|x|$ can be obtained from the graph of $y = |x|$ by vertically stretching by a factor of ___ and reflecting across the ___-axis. 16) _____

A) -6; y B) 6; y C) -6; x D) 6; x

17) The graph of $y = -2x^2$ can be obtained from the graph of $y = x^2$ by vertically stretching by a factor of ___ and reflecting across the ___-axis. 17) _____

A) -2; x B) 2; y C) 2; x D) -2; y

18) The graph of $y = -5(x-4)^2 + 8$ can be obtained from the graph of $y = x^2$ by shifting horizontally ___ units to the _____, vertically stretching by a factor of _____, reflecting across the ___-axis, and shifting vertically ___ units in the _____ direction. 18) _____

A) 4; right; 8; x; 5; upward B) 4; right; 8; y; 5; downward

C) 4; left; 5; x; 8; upward D) 4; right; 5; x; 8; upward

19) The graph of $y = -6(x+3)^2 - 8$ can be obtained from the graph of $y = x^2$ by shifting horizontally ___ units to the _____, vertically stretching by a factor of _____, reflecting across the ___-axis, and shifting vertically ___ units in the _____ direction. 19) _____

- A) 3; left; 6; x; 8; downward B) 3; right; 6; x; 8; downward
C) 3; left; 8; x; 6; downward D) 3; right; 6; x; 8; upward

20) The graph of $y = -\frac{1}{5}(x+2)^2 - 8$ can be obtained from the graph of $y = x^2$ by shifting horizontally ___ units to the _____, vertically shrinking by a factor of _____, reflecting across the ___-axis, and shifting vertically ___ units in the _____ direction. 20) _____

- A) 2; left; $\frac{1}{5}$; x; 8; downward B) 2; right; $\frac{1}{5}$; x; 8; downward
C) 2; left; 8; x; $\frac{1}{5}$; downward D) 2; right; $\frac{1}{5}$; x; 8; upward

21) The graph of $y = -\frac{1}{3}|-x| + 2$ can be obtained from the graph of $y = |x|$ by reflecting across the ___-axis, vertically shrinking by a factor of _____, reflecting across the ___-axis, and shifting vertically ___ units in the _____ direction. 21) _____

- A) $y; \frac{1}{3}; x; 2; \text{downward}$ B) $y; \frac{1}{3}; x; 2; \text{upward}$
C) $x; \frac{1}{3}; x; 2; \text{upward}$ D) $x; 2; y; \frac{1}{3}; \text{upward}$

Give the equation of the function whose graph is described.

22) The graph of $y = |x|$ is vertically stretched by a factor of 6, and the resulting graph is reflected across the x-axis. 22) _____

- A) $y = 6|-x|$ B) $y = -6|-x|$ C) $y = -6|x|$ D) $y = -|x+6|$

23) The graph of $y = x^2$ is shifted 4 units to the right. This graph is then vertically stretched by a factor of 6 and reflected across the x-axis. Finally, the graph is shifted 8 units upward. 23) _____

- A) $y = -6(x+8)^2 + 4$ B) $y = -6(x-4)^2 - 8$
C) $y = -6(x-4)^2 + 8$ D) $y = -6(x+4)^2 + 8$

24) The graph of $y = x^2$ is shifted 4 units to the left. This graph is then vertically stretched by a factor of 6 and reflected across the x-axis. Finally, the graph is shifted 8 units downward. 24) _____

- A) $y = -6(x-4)^2 + 8$ B) $y = -6(x-4)^2 - 8$
C) $y = -6(x+4)^2 - 8$ D) $y = -6(x+8)^2 - 4$

25) The graph of $y = x^2$ is shifted 3 units to the left. This graph is then vertically shrunk by a factor of $\frac{1}{5}$ and reflected across the x-axis. Finally, the graph is shifted 7 units downward. 25) _____

A) $y = \frac{1}{5}(x-3)^2 - 7$ B) $y = -\frac{1}{5}(x-3)^2 - 7$
 C) $y = -\frac{1}{5}(x-3)^2 + 7$ D) $y = -\frac{1}{5}(x+3)^2 - 7$

26) The graph of $y = |x|$ is reflected across the y-axis and vertically shrunk by a factor of $\frac{2}{3}$. This graph is then reflected across the x-axis. Finally, the graph is shifted 2 units upward. 26) _____

A) $y = \frac{2}{3}|x| + 2$ B) $y = \left| -x - \frac{2}{3} \right| + 2$ C) $y = -\frac{2}{3}|-x| + 2$ D) $y = \frac{2}{3}|x+2|$

27) The graph of $y = x^3$ is shifted 2.4 units to the right and then vertically shrunk by a factor of 0.5. 27) _____

A) $y = 0.5(x-2.4)^3$ B) $y = 2.4(x-0.5)^3$ C) $y = 0.5x^3 + 2.4$ D) $y = 0.5(x+2.4)^3$

28) The graph of $y = |x|$ is vertically stretched by a factor of 3.9. This graph is then reflected across the x-axis. Finally, the graph is shifted 0.79 units downward. 28) _____

A) $y = 3.9|x - 0.79|$ B) $y = 3.9|x| - 0.79$ C) $y = -3.9|x| - 0.79$ D) $y = 3.9|-x| - 0.79$

29) The graph of $y = |x|$ is reflected across the y-axis. This graph is then vertically stretched by a factor of 4.7. Finally, the graph is shifted 9 units downward. 29) _____

A) $y = 4.7|-x| - 9$ B) $y = 4.7|-x| - 9$ C) $y = -4.7|x| - 9$ D) $y = 4.7|-x| + 9$

30) The graph of $y = \sqrt[3]{x}$ is shifted 8.9 units to the left. This graph is then vertically stretched by a factor of 6.1. Finally, the graph is reflected across the x-axis. 30) _____

A) $y = -6.1\sqrt[3]{x-8.9}$ B) $y = -8.9\sqrt[3]{x+6.1}$ C) $y = -6.1\sqrt[3]{x+8.9}$ D) $y = 6.1\sqrt[3]{x+8.9}$

The graph of the given function is drawn with a solid line. The graph of a function, $g(x)$, transformed from this one is drawn with a dashed line. Find a formula for $g(x)$.

31) $f(x) = |x|$

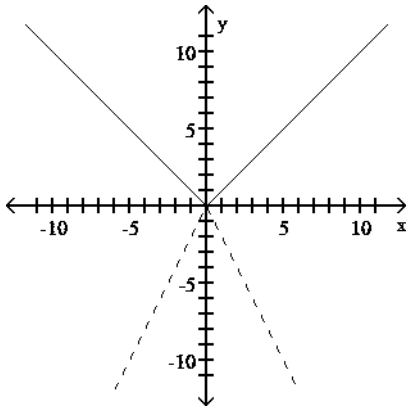

31) _____

- A) $g(x) = |x + 2|$ B) $g(x) = |x - 2|$ C) $g(x) = -2|x|$ D) $g(x) = |x| - 2$

32) $f(x) = x^2$

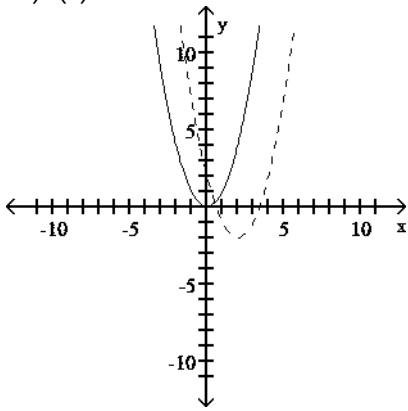

32) _____

- A) $g(x) = (x - 2)^2 - 2$ B) $g(x) = (x - 4)^2 - 2$
 C) $g(x) = 4(x + 2)^2$ D) $g(x) = -4(x - 2)^2$

33) $f(x) = x^2$

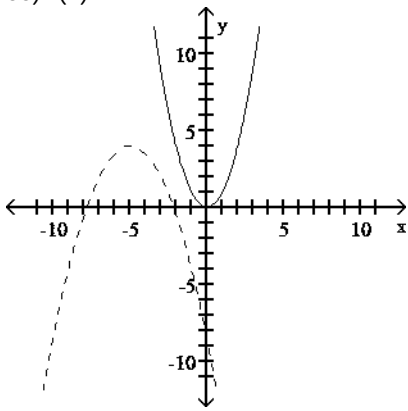

33) _____

- A) $g(x) = -\frac{1}{2}(x + 5)^2$ B) $g(x) = (x + 5)^2 + 4$
 C) $g(x) = \frac{1}{2}(x - 5)^2 - 4$ D) $g(x) = -\frac{1}{2}(x + 5)^2 + 4$

34) $f(x) = |x|$

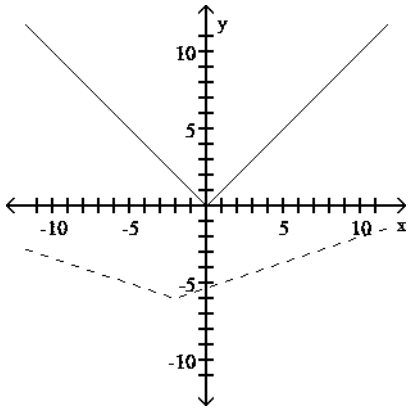

34) _____

- A) $g(x) = 6|x-2| + 0.33$ B) $g(x) = 0.33|x-2| + 6$
 C) $g(x) = 6|x+2| - 0.33$ D) $g(x) = 0.33|x+2| - 6$

Use transformations to graph the function.

35) $f(x) = -4|x|$

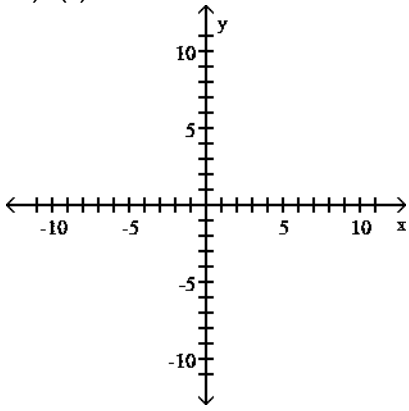

35) _____

A)

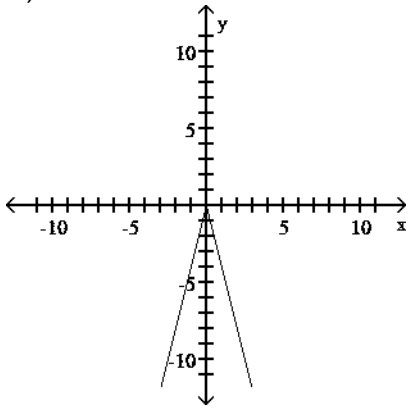

B)

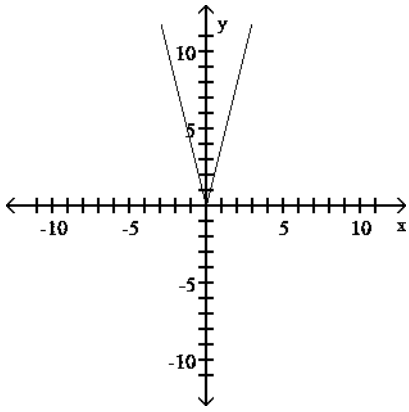

C)

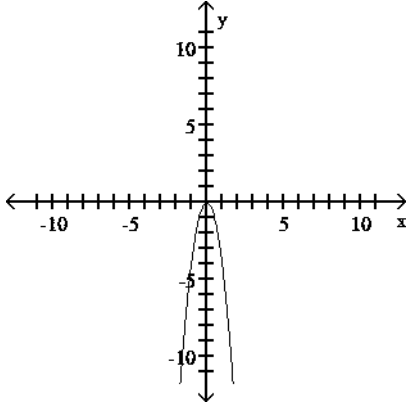
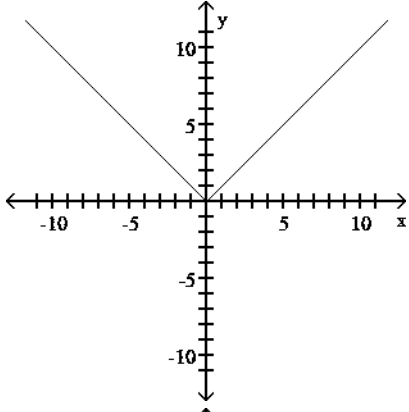

D)

36) $f(x) = 2x^2 - 6$

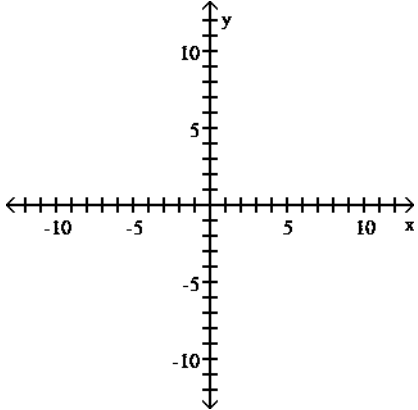

36) _____

A)

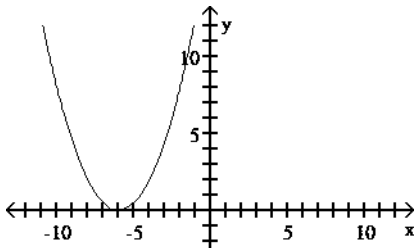

B)

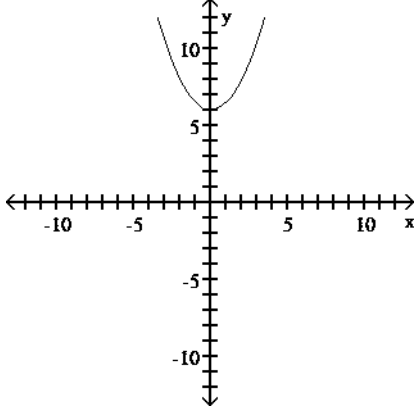

C)

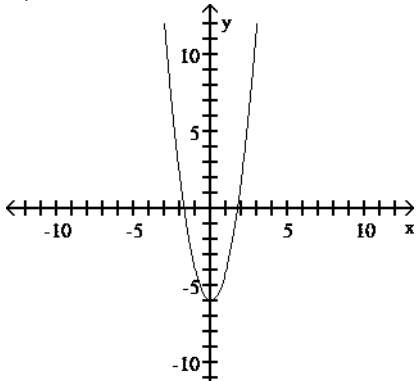

D)

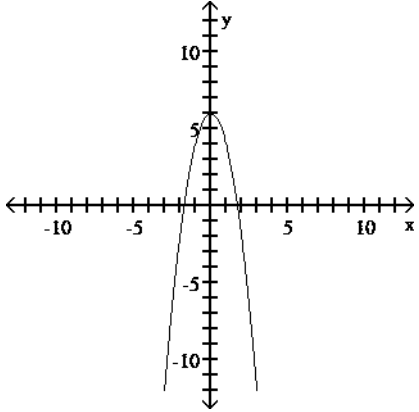

37) $f(x) = |-6 - x|$

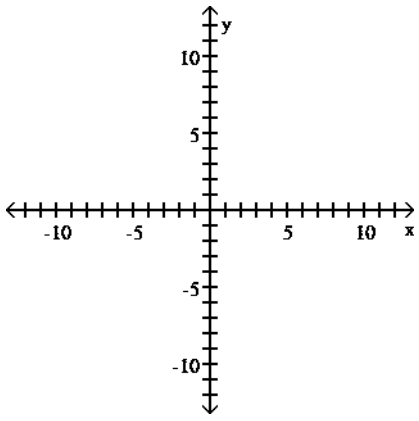

37) _____

A)

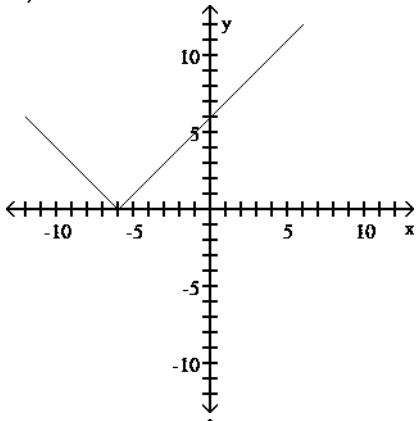

B)

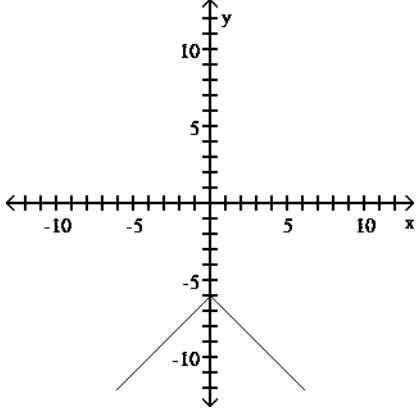

C)

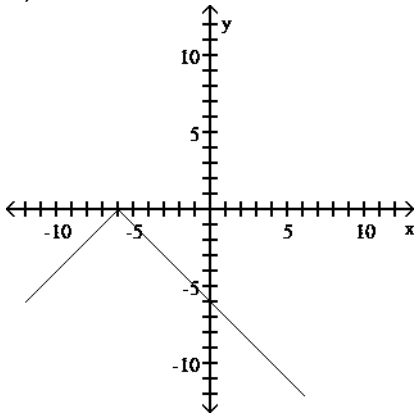

D)

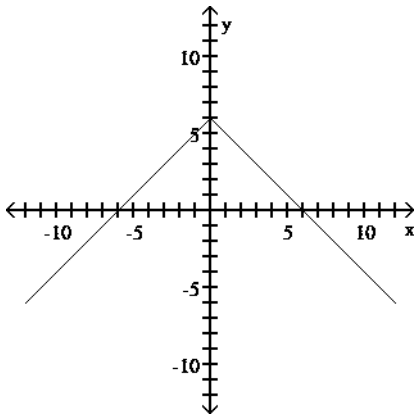

38) $f(x) = 6|x| - 8$

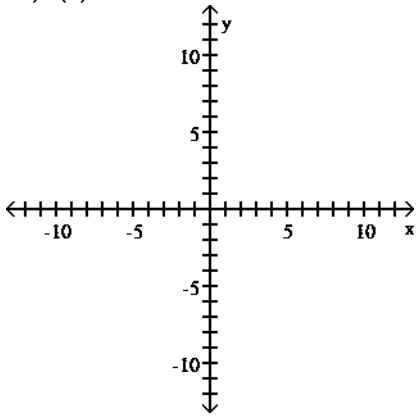

38) _____

A)

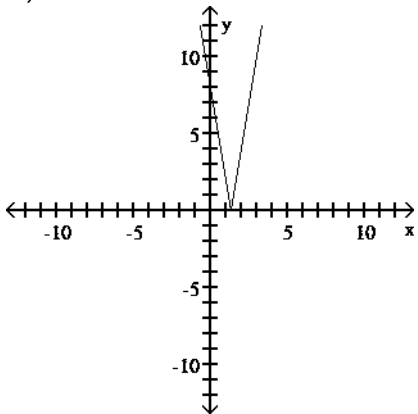

B)

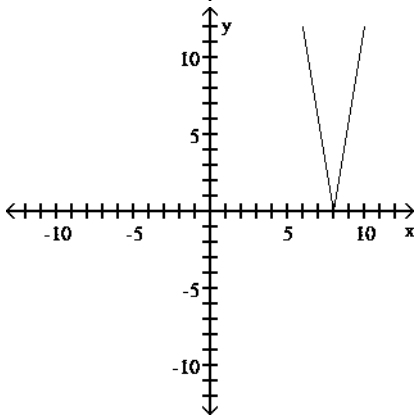

C)

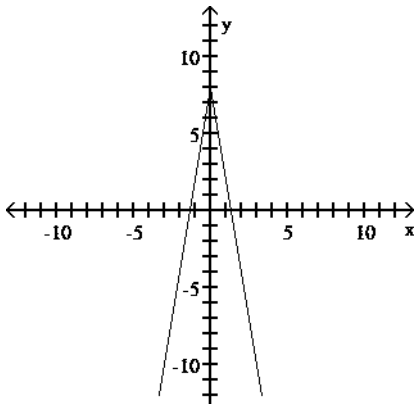

D)

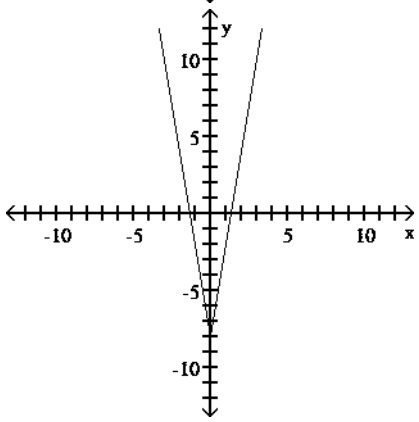

39) $f(x) = |x - 5| - 2$

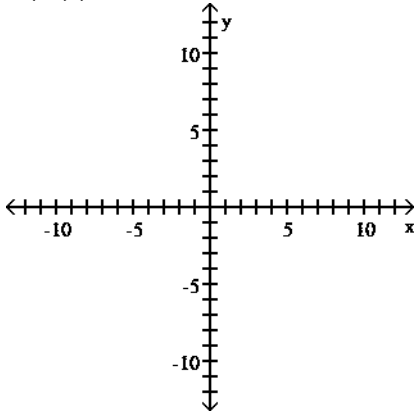

39) _____

A)

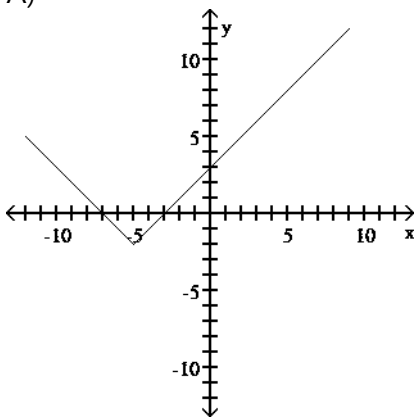

B)

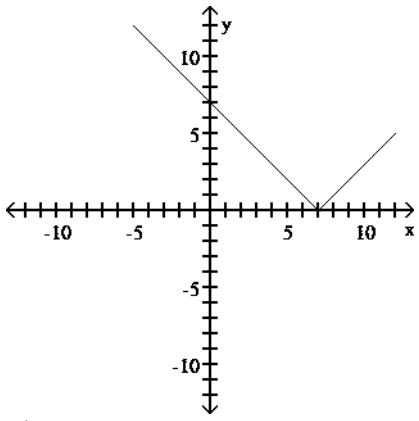

C)

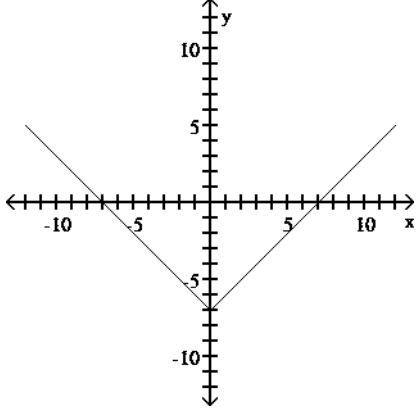
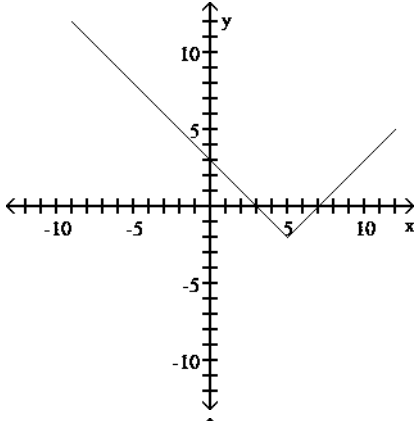

D)

40) $f(x) = 2|x - 6| - 4$

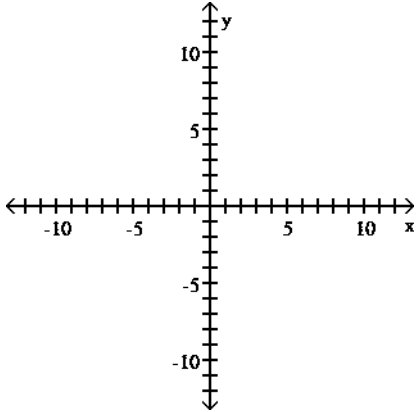

40) _____

A)

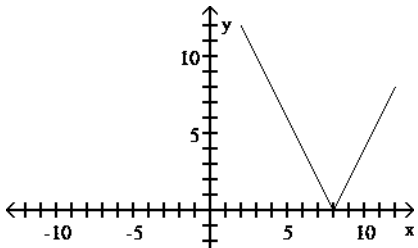

B)

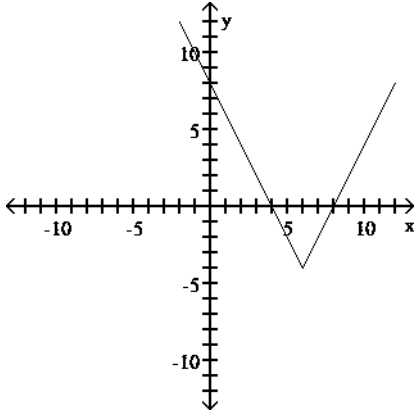

C)

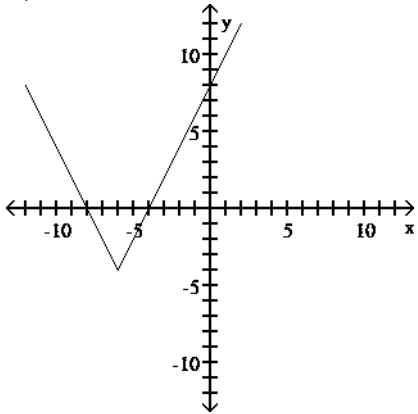

D)

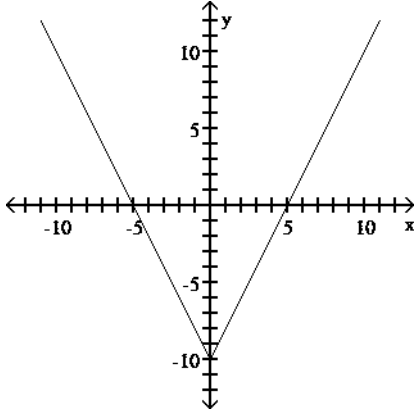

41) $f(x) = -\sqrt{x+2} + 1$

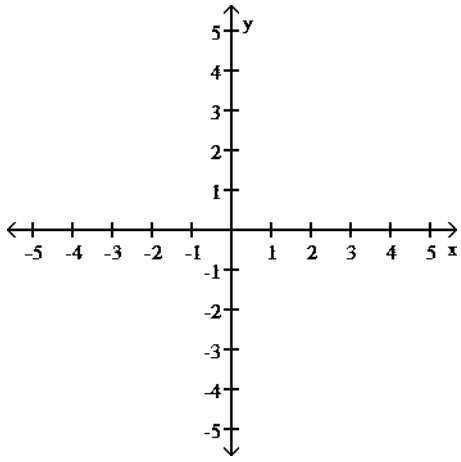

41) _____

A)

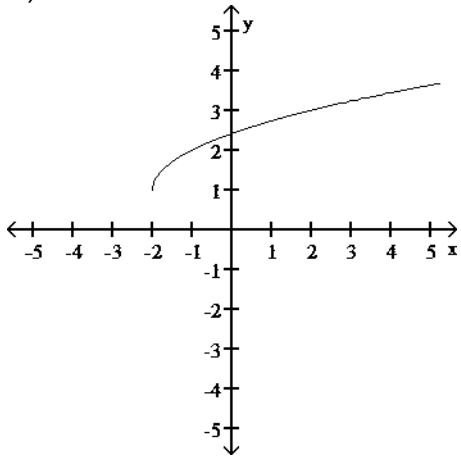

B)

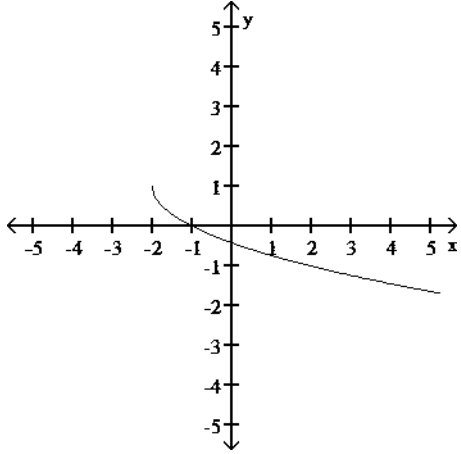

C)

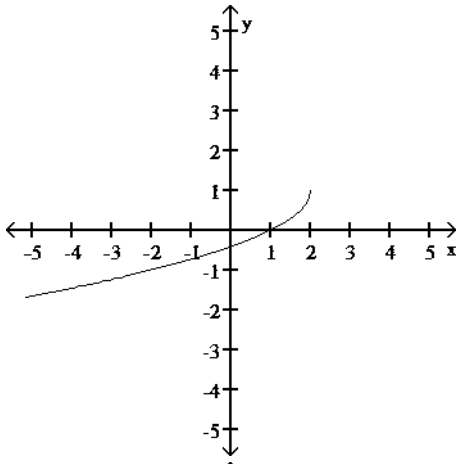

D)

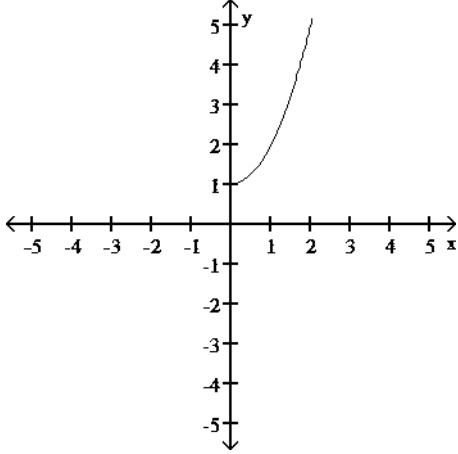

42) $f(x) = (x-3)^2 - 6$

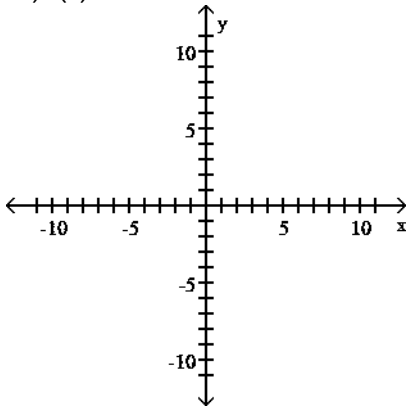

42) _____

A)

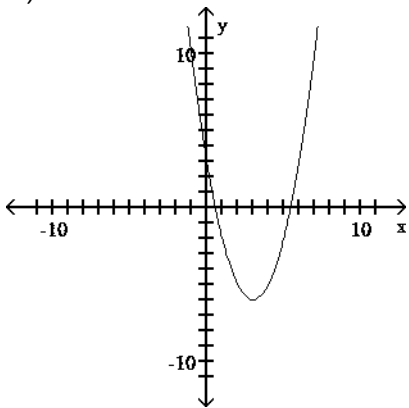

B)

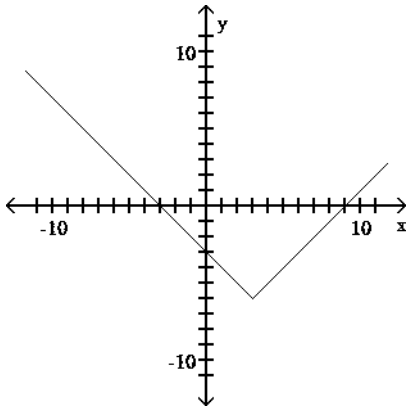

C)

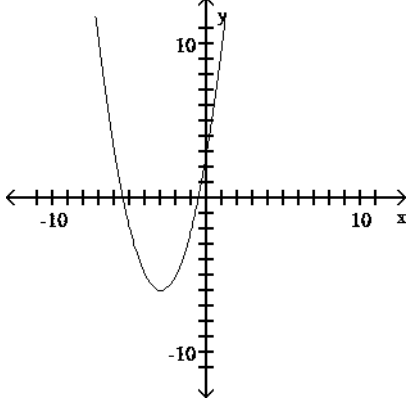
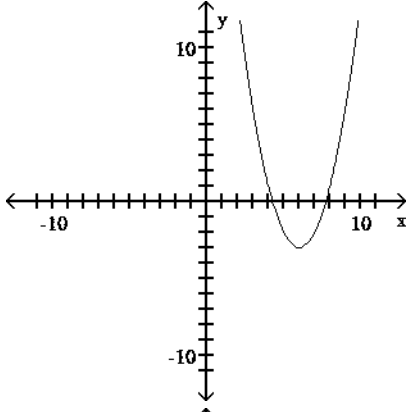

D)

43) $f(x) = -3(x + 3)^2 + 5$

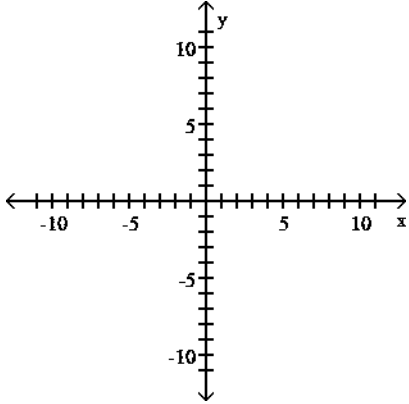

43) _____

A)

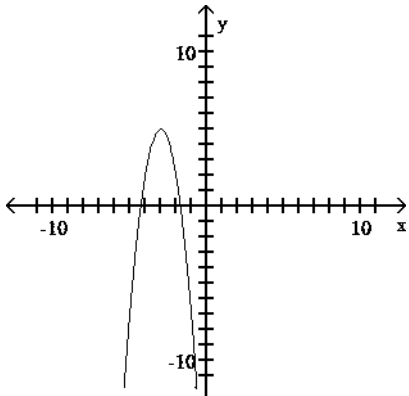

B)

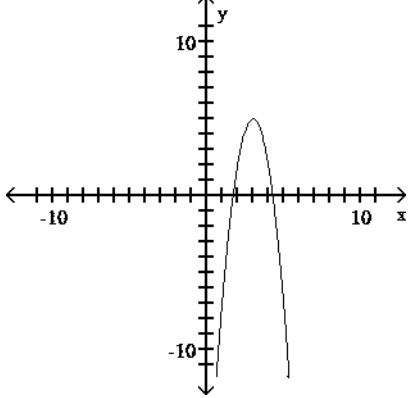

C)

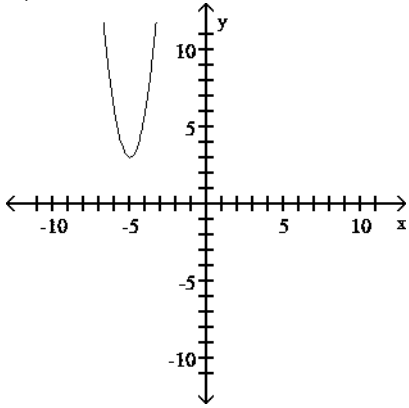

D)

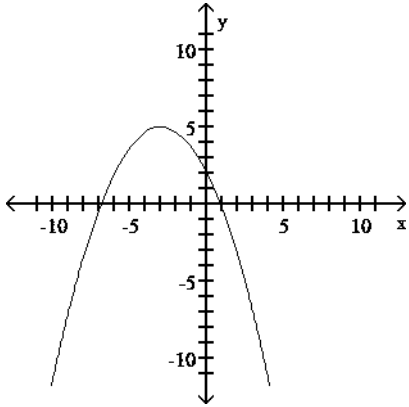

Use the accompanying graph of $y = f(x)$ to sketch the graph of the indicated function.

44) $y = -f(x)$

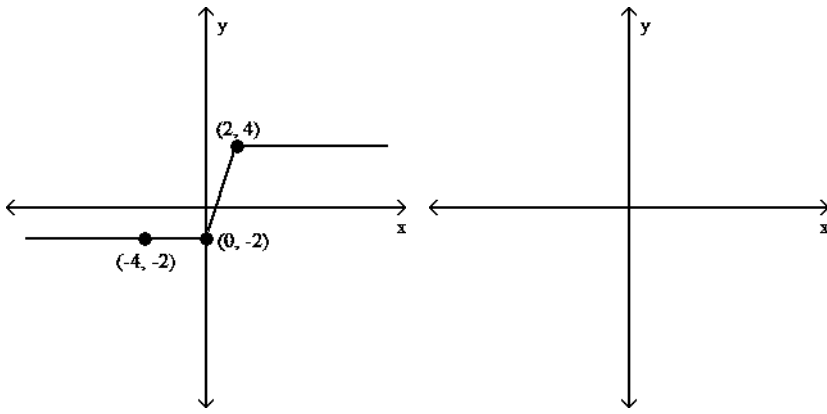

44) _____

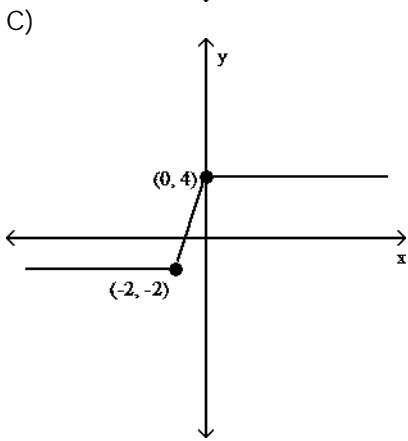
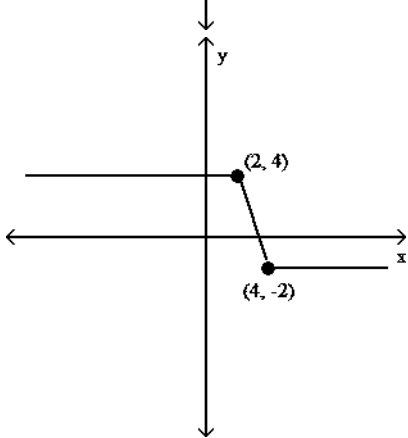
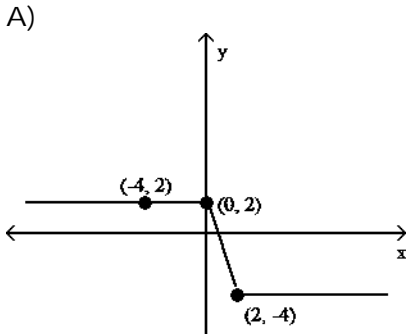

D)

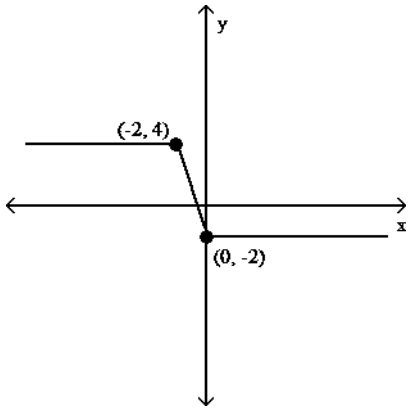

45) $y = f(-x)$

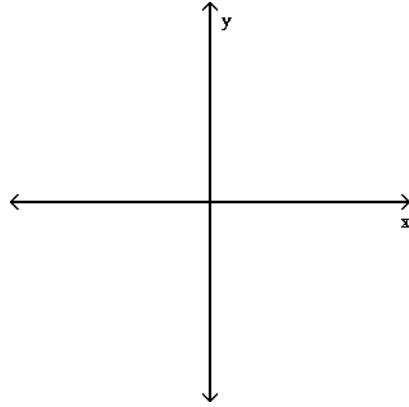
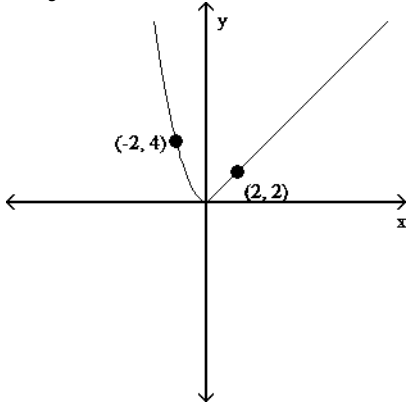

45) _____

A)

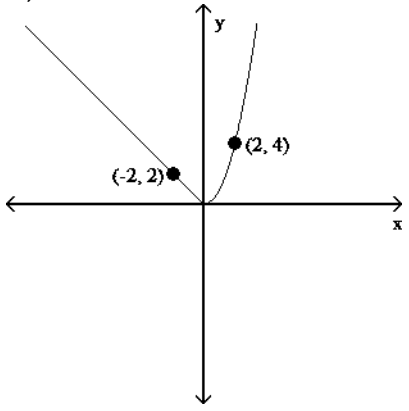

B)

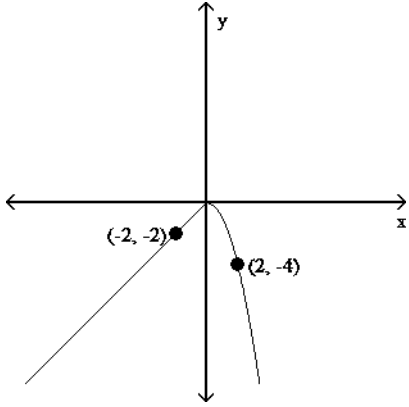

C)

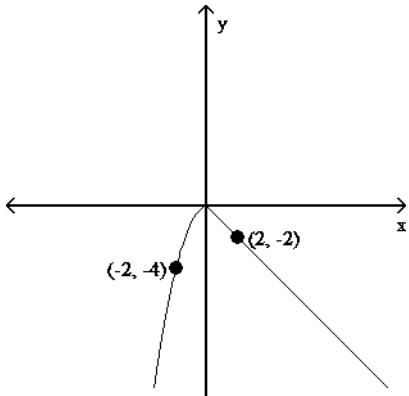

D)

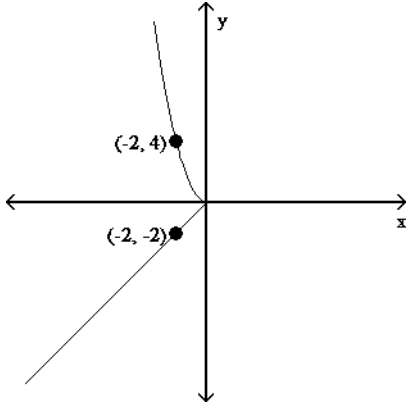

46) $y = f(-x)$

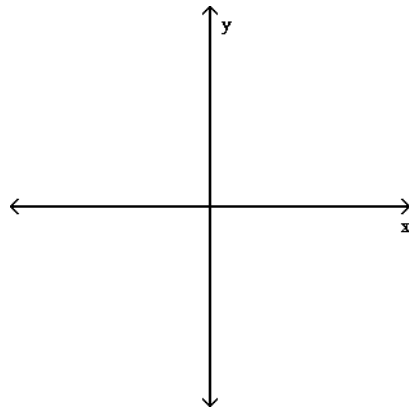
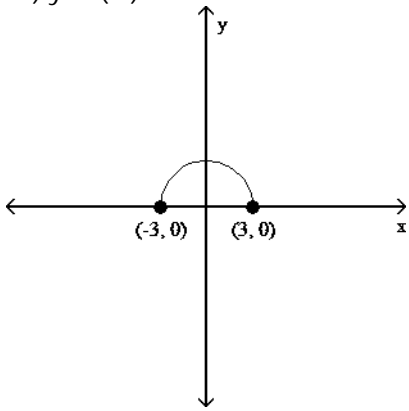

46) _____

A)

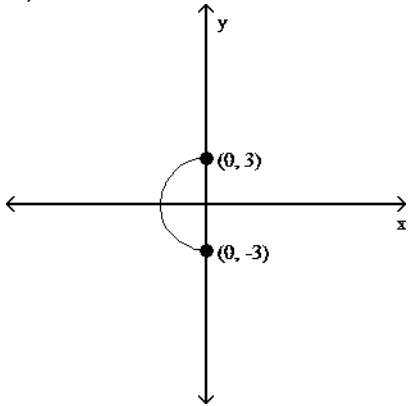

B)

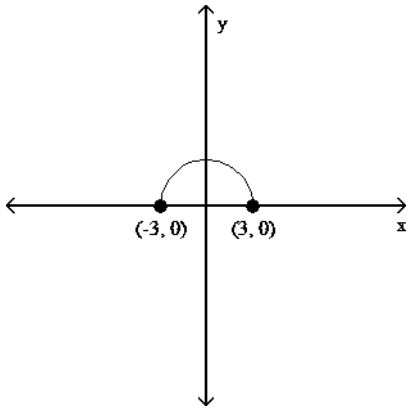

C)

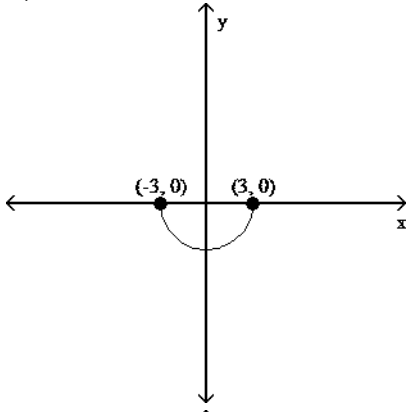

D)

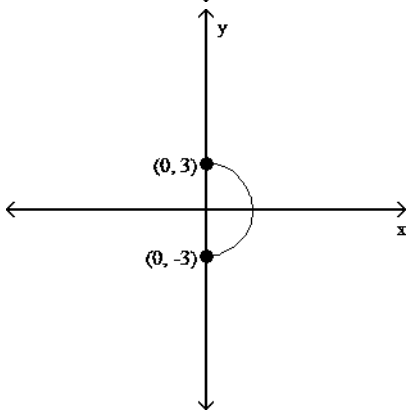

47) $y = -f(x)$

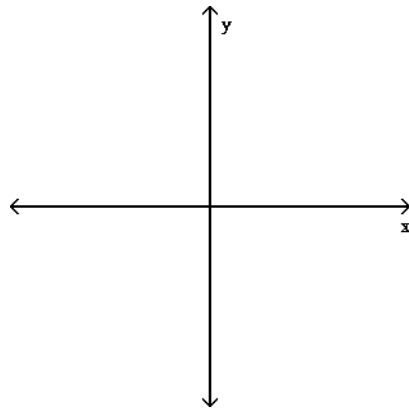
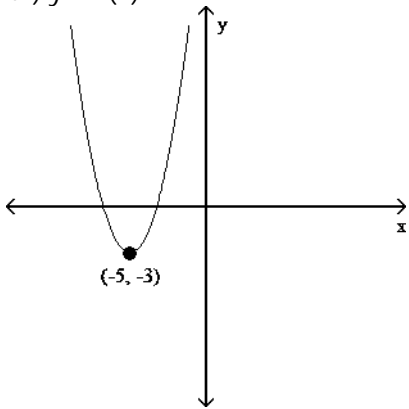

47) _____

A)

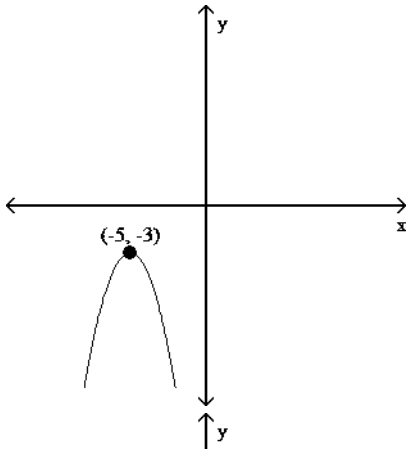

B)

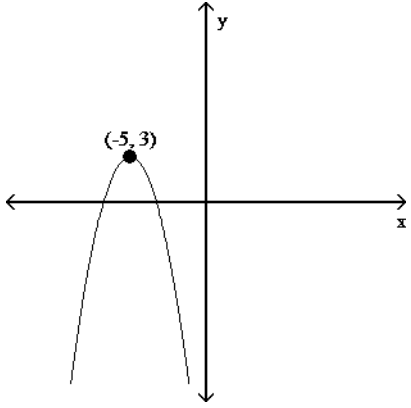

C)

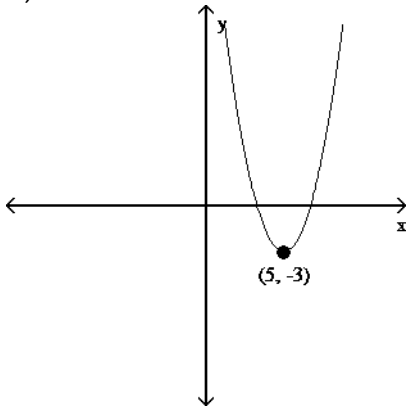

D)

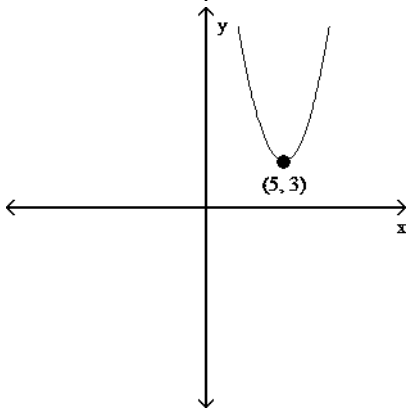

48) $y = 2f(x)$

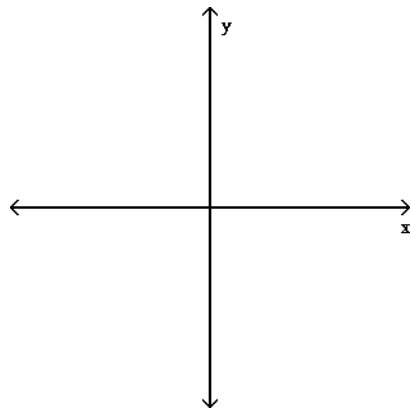
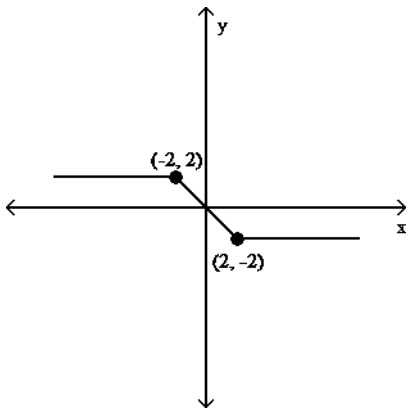

48) _____

A)

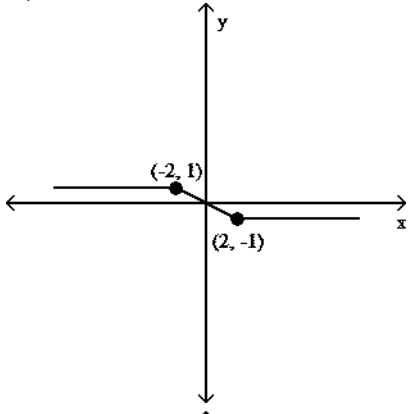

B)

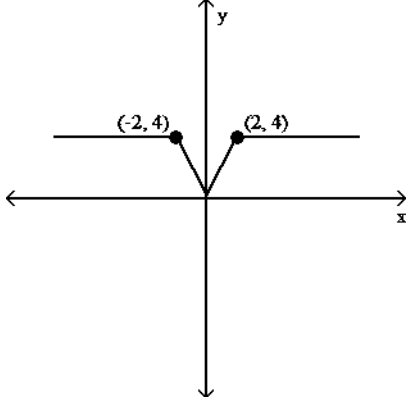

C)

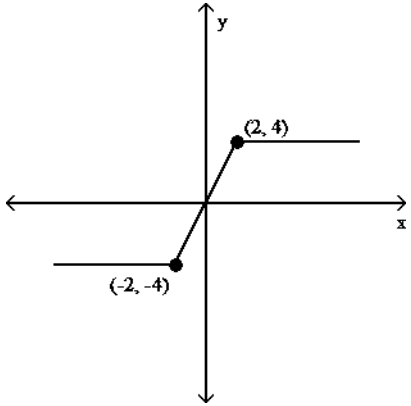

D)

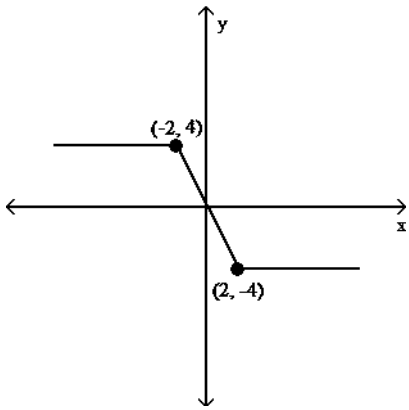

49) $y = -\frac{1}{2}f(x)$

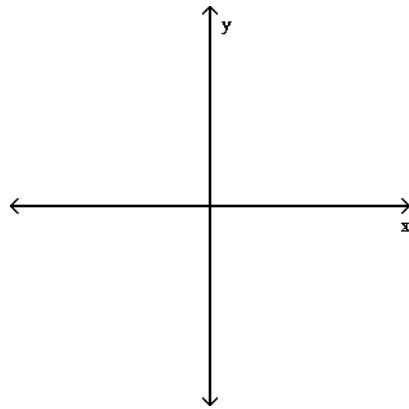
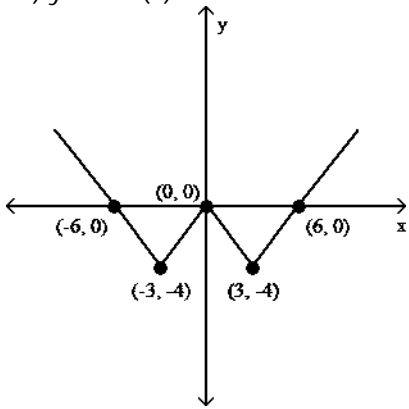

49) _____

A)

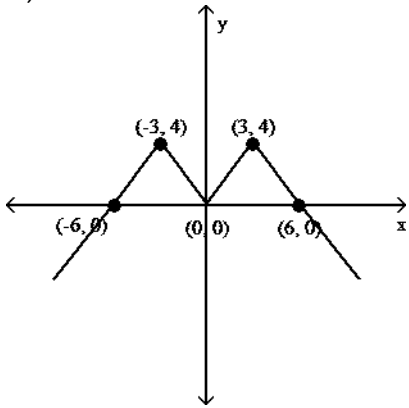

B)

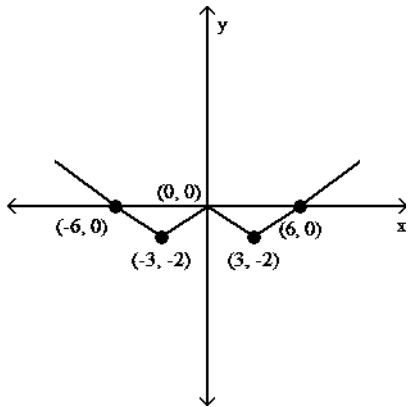

C)

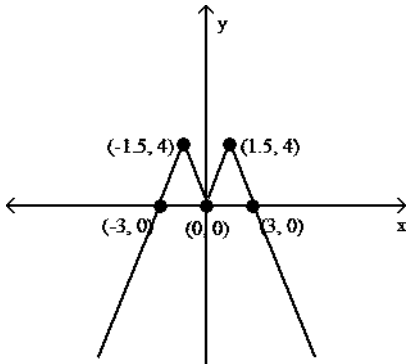

D)

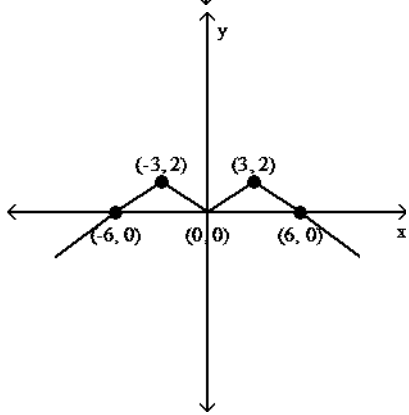

50) $y = -f(2x)$

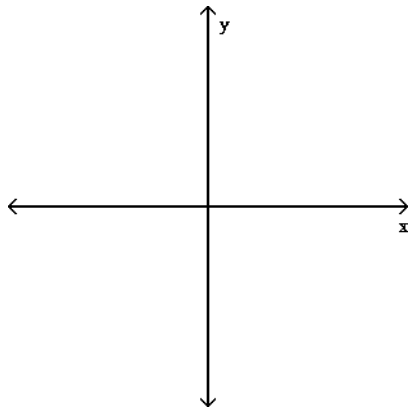
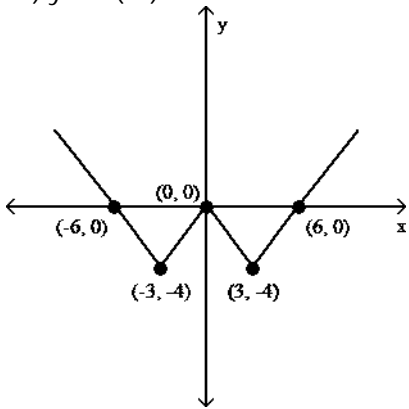

50) _____

A)

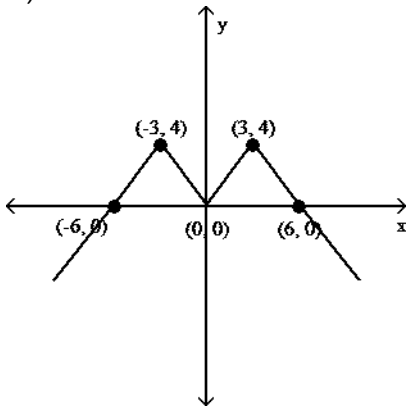

B)

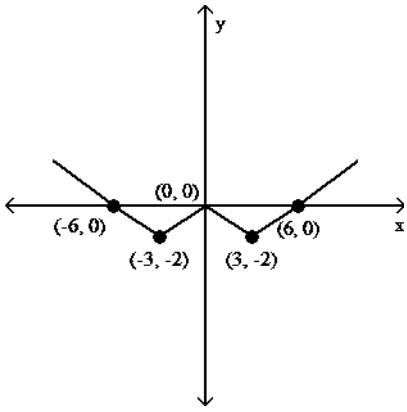

C)

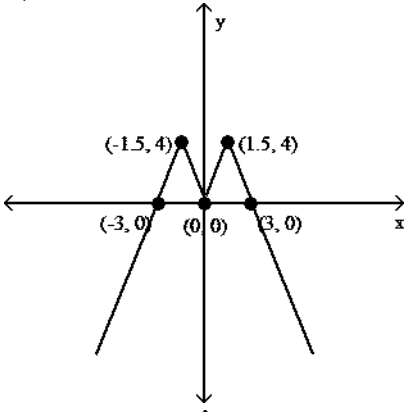

D)

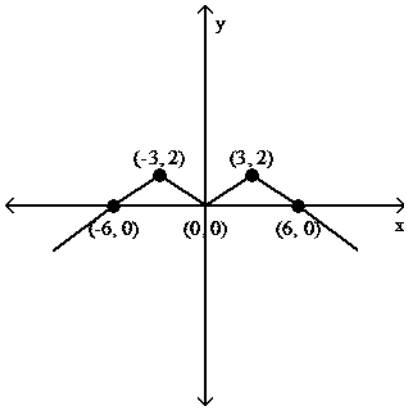

51) $y = f(x - 3)$

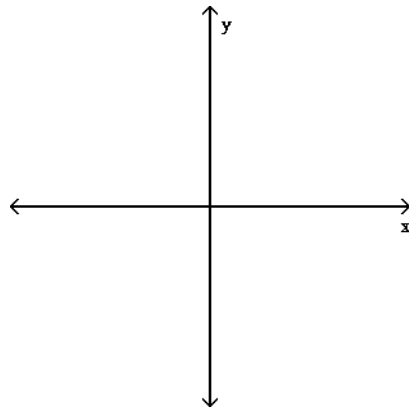
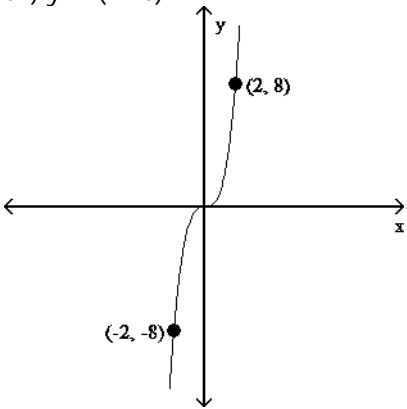

51) _____

A)

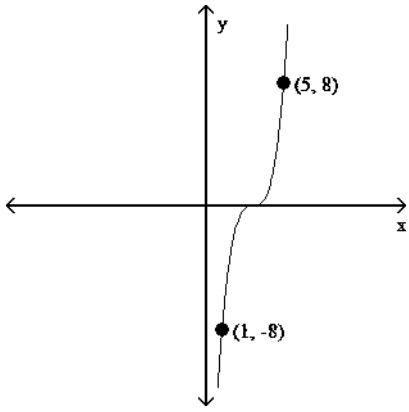

B)

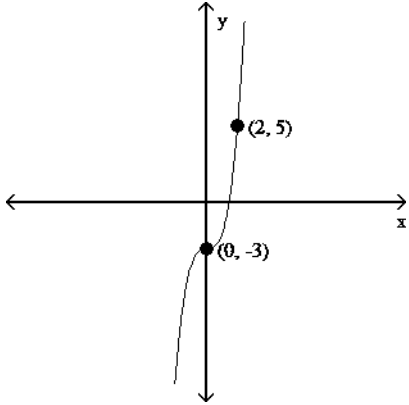

C)

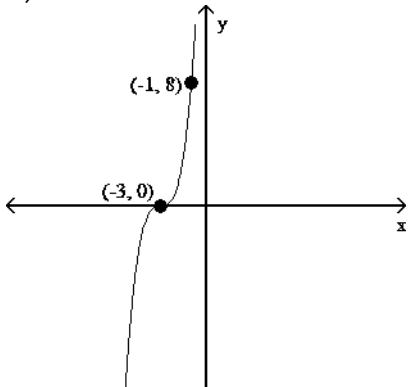

D)

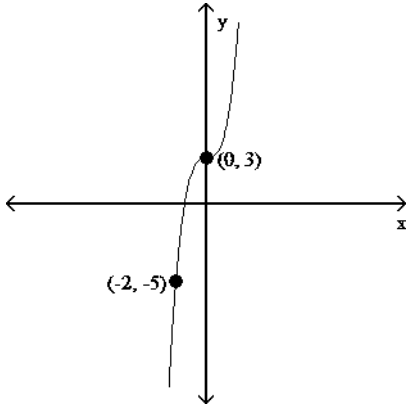

52) $y = -2f(x + 2) + 5$

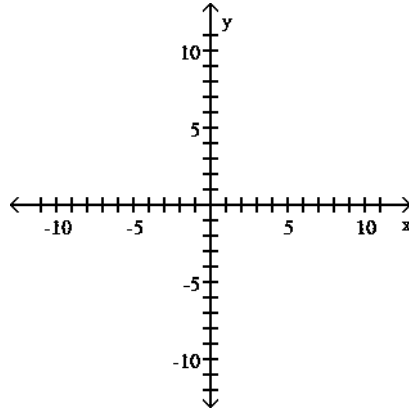
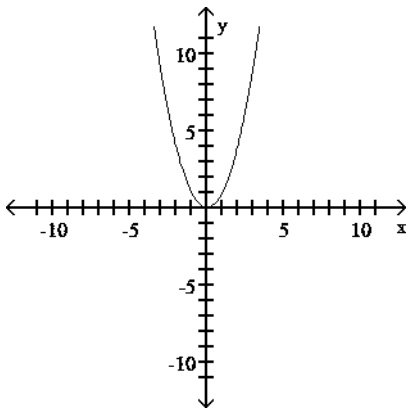

52) _____

A)

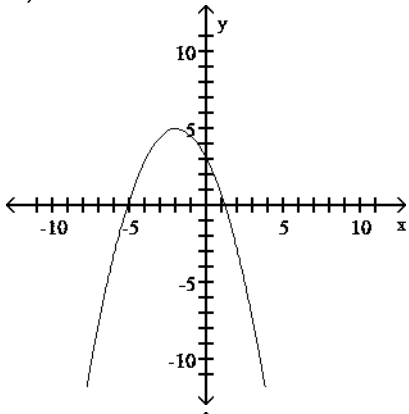

B)

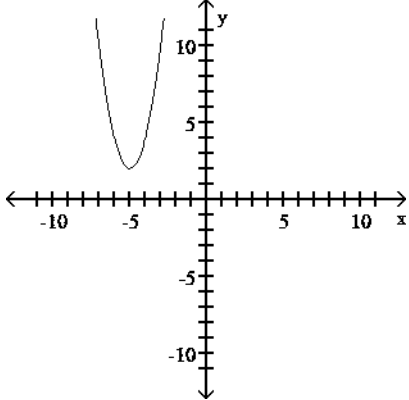

C)

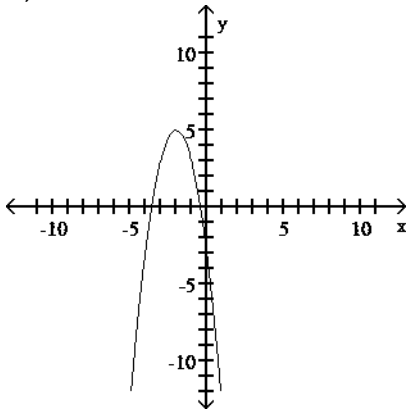

D)

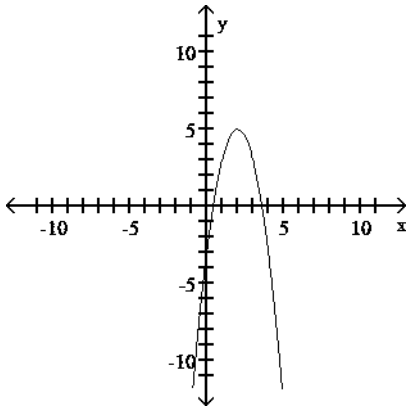

Let f be a function with the given domain and range. Find the domain and range of the indicated function.

53) Domain of $f(x)$: $[4, 9]$; Range of $f(x)$: $[0, 5]$

$-f(x)$ 53) _____

- A) D: $[4, 9]$; R: $[-5, 0]$ B) D: $[-9, -4]$; R: $[-5, 0]$
 C) D: $[-9, -4]$; R: $[0, 5]$ D) D: $[4, 9]$; R: $[0, 5]$

54) Domain of $f(x)$: $[1, 6]$; Range of $f(x)$: $[0, 5]$

$f(-x)$ 54) _____

- A) D: $[1, 6]$; R: $[0, 5]$ B) D: $[-6, -1]$; R: $[-5, 0]$
 C) D: $[1, 6]$; R: $[-5, 0]$ D) D: $[-6, -1]$; R: $[0, 5]$

55) Domain of $f(x)$: $[3, 4]$; Range of $f(x)$: $[0, 4]$

$f(x - 1)$ 55) _____

- A) D: $[3, 4]$; R: $[-1, 3]$ B) D: $[4, 5]$; R: $[0, 4]$
 C) D: $[2, 7]$; R: $[0, 4]$ D) D: $[3, 8]$; R: $[1, 5]$

56) Domain of $f(x)$: $[-6, 7]$; Range of $f(x)$: $[0, 3]$

$f(x + 2) + 3$ 56) _____

- A) D: $[-4, 9]$; R: $[-3, 0]$ B) D: $[-4, 9]$; R: $[3, 6]$
 C) D: $[-8, 5]$; R: $[3, 6]$ D) D: $[-8, 5]$; R: $[-3, 0]$

57) Domain of $f(x)$: $[-1, 2]$; Range of $f(x)$: $[0, 4]$

$6f(x + 2)$ 57) _____

- A) D: $[1, 4]$; R: $[0, 24]$ B) D: $[-3, 0]$; R: $[0, 24]$
 C) D: $[-3, 0]$; R: $[6, 10]$ D) D: $[1, 4]$; R: $[6, 10]$

58) Domain of $f(x)$: $[-7, 0]$; Range of $f(x)$: $[0, 1]$

$f(-2x)$ 58) _____

- A) D: $[-7, 0]$; R: $[-2, 0]$ B) D: $\left[0, \frac{7}{2}\right]$; R: $[0, 1]$
 C) D: $[0, 14]$; R: $[0, 1]$ D) D: $[-7, 0]$; R: $\left[-\frac{1}{2}, 0\right]$

59) Domain of $f(x)$: $[-1, 0]$; Range of $f(x)$: $[0, 3]$

$2f\left(\frac{1}{5}x\right)$ 59) _____

- A) D: $[-2, 0]$; R: $[0, 15]$ B) D: $\left[-\frac{1}{5}, 0\right]$; R: $[0, 6]$
 C) D: $\left[-\frac{1}{5}, 0\right]$; R: $\left[0, \frac{3}{2}\right]$ D) D: $[-5, 0]$; R: $[0, 6]$

Determine the intervals on which the function is increasing, decreasing, and constant.

60)

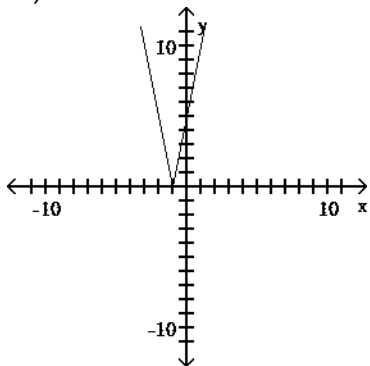

60) _____

- A) Increasing on $(-\infty, -1)$; Decreasing on $(-1, \infty)$
 B) Increasing on $(-1, \infty)$; Decreasing on $(-\infty, -1)$
 C) Increasing on $(1, \infty)$; Decreasing on $(-\infty, 1)$
 D) Increasing on $(-\infty, 1)$; Decreasing on $(1, \infty)$

61)

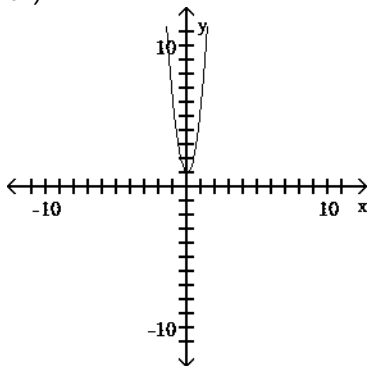

61) _____

- A) Increasing on $(0, \infty)$; Decreasing on $(-\infty, 0)$
 B) Increasing on $(-\infty, 0)$; Decreasing on $(-\infty, 0)$
 C) Increasing on $(\infty, 0)$; Decreasing on $(0, -\infty)$
 D) Increasing on $(-\infty, 0)$; Decreasing on $(0, \infty)$

62)

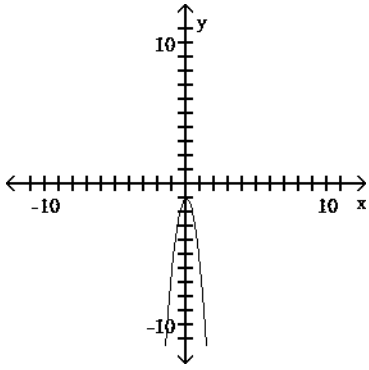

62) _____

- A) Increasing on $(\infty, 0)$; Decreasing on $(0, -\infty)$
- B) Increasing on $(0, \infty)$; Decreasing on $(-\infty, 0)$
- C) Increasing on $(-\infty, 0)$; Decreasing on $(0, \infty)$
- D) Increasing on $(-\infty, 0)$; Decreasing on $(-\infty, 0)$

63)

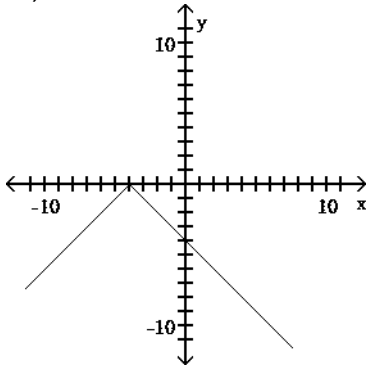

63) _____

- A) Increasing on $(-4, \infty)$; Decreasing on $(-\infty, -4)$
- B) Increasing on $(-4, \infty)$; Decreasing on $(-4, \infty)$
- C) Increasing on $(-\infty, -4)$; Decreasing on $(-\infty, -4)$
- D) Increasing on $(-\infty, -4)$; Decreasing on $(-4, \infty)$

64)

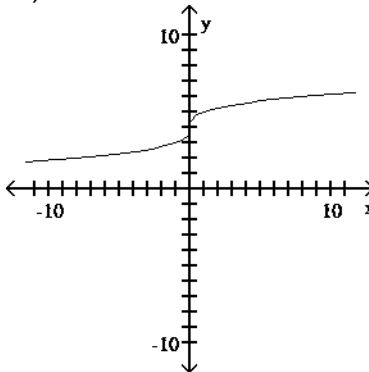

64) _____

- A) Decreasing on $(-\infty, \infty)$
- B) Increasing on $(-\infty, \infty)$
- C) Increasing on $(-\infty, 0)$; Decreasing on $(0, \infty)$
- D) Increasing on $(0, \infty)$; Decreasing on $(-\infty, 0)$

65)

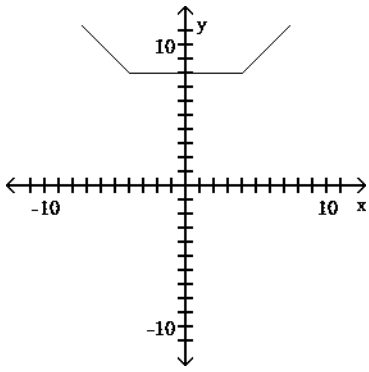

65) _____

- A) Increasing on $(4, \infty)$; Decreasing on $(-\infty, -4)$; Constant on $(-4, 4)$
- B) Increasing on $(-\infty, 4)$; Decreasing on $(-\infty, -4)$; Constant on $(4, \infty)$
- C) Increasing on $(-\infty, 4)$; Decreasing on $(-4, \infty)$; Constant on $(4, \infty)$
- D) Increasing on $(4, \infty)$; Decreasing on $(-4, \infty)$; Constant on $(-4, 4)$

66)

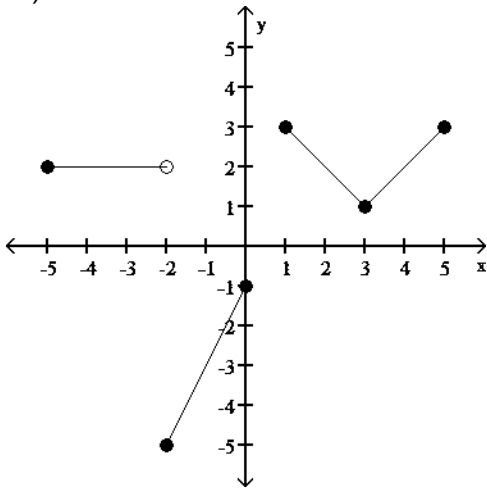

66) _____

- A) Increasing on $(-1, 0)$ and $(3, 5)$; Decreasing on $(0, 3)$; Constant on $(-5, -3)$
- B) Increasing on $(-2, 0)$ and $(3, 4)$; Decreasing on $(-5, -2)$ and $(1, 3)$
- C) Increasing on $(1, 3)$; Decreasing on $(-2, 0)$ and $(3, 5)$; Constant on $(2, 5)$
- D) Increasing on $(-2, 0)$ and $(3, 5)$; Decreasing on $(1, 3)$; Constant on $(-5, -2)$

67)

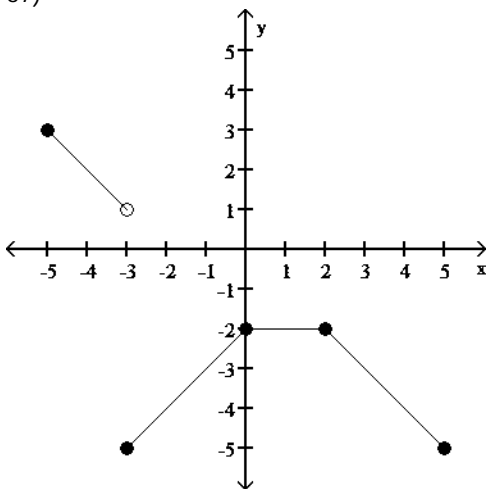

67) _____

- A) Increasing on (-3, 1); Decreasing on (-5, -3) and (0, 5); Constant on (1, 2)
- B) Increasing on (-3, 0); Decreasing on (-5, -3) and (2, 5); Constant on (0, 2)
- C) Increasing on (-5, -3) and (2, 5); Decreasing on (-3, 0); Constant on (0, 2)
- D) Increasing on (-3, -1); Decreasing on (-5, -2) and (2, 4); Constant on (-1, 2)

Shown here are graphs of y_1 and y_2 . The point whose coordinates are given at the bottom of the screen lies on the graph of y_1 . Use this graph, and not your own calculator, to find the value of y_2 for the same value of x shown.

68)

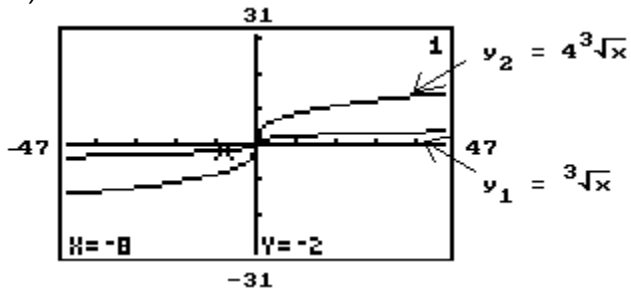

68) _____

- A) -8 B) 2 C) -32 D) -2

69)

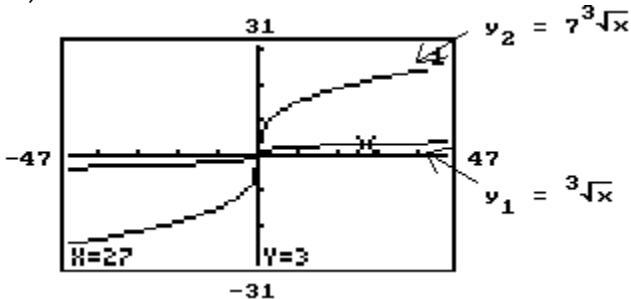

69) _____

- A) -2.3333333 B) 2.3333333 C) 27 D) 21

70)

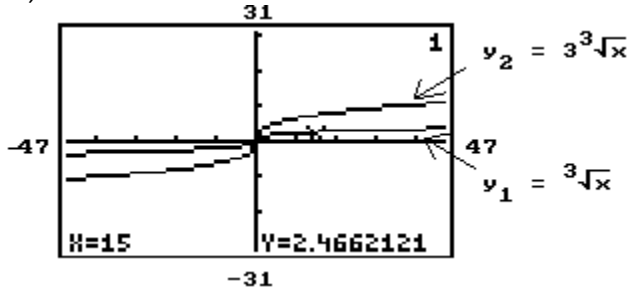

70) _____

- A) 14.797273 B) 0.8220707 C) -7.3986363 D) 7.3986363

71)

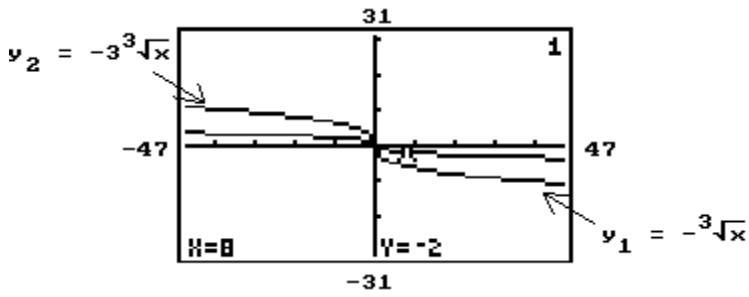

71) _____

- A) -9 B) -6 C) 6 D) -1.5

72)

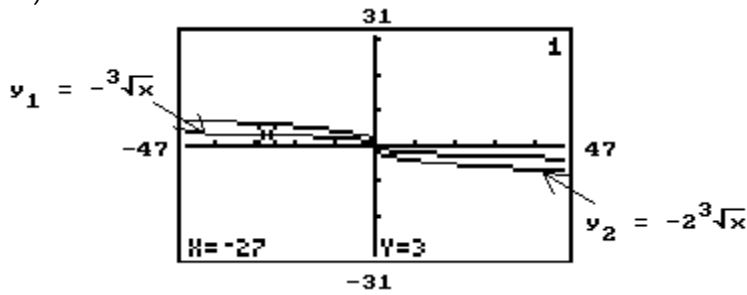

72) _____

- A) 0.666666 B) 6 C) -6 D) 27

73)

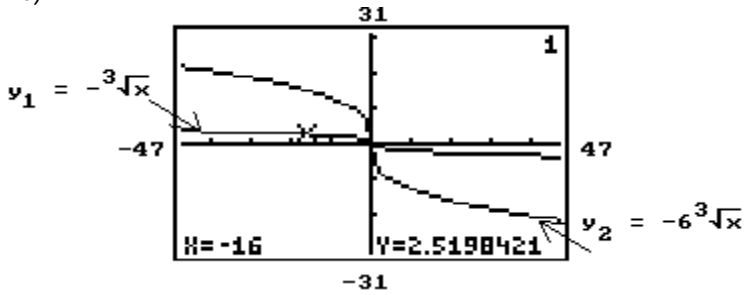

73) _____

- A) -16 B) 0.4199736 C) -15.119053 D) 15.119053

The figure shows a transformation of the graph of $y = x^2$. Write the equation for the graph.

74)

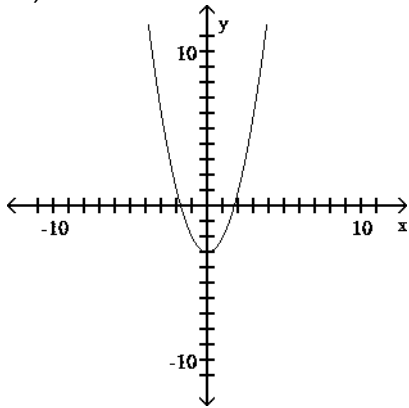

74) _____

- A) $g(x) = x^2 - 3$ B) $g(x) = (x-3)^2 + 3$
 C) $g(x) = (x+3)^2$ D) $g(x) = (x-3)^2$

75)

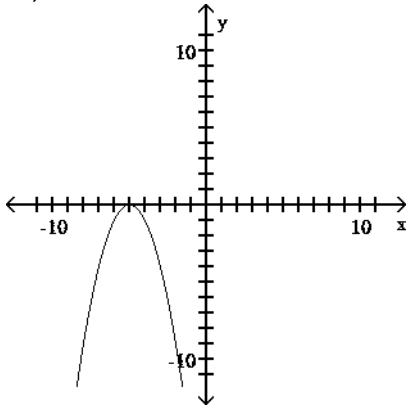

75) _____

- A) $g(x) = -x^2 + 5$ B) $g(x) = (x - 5)^2$ C) $g(x) = -(x + 5)^2$ D) $g(x) = -x^2 - 5$

76)

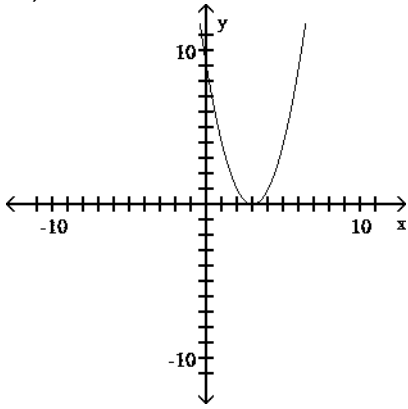

76) _____

- A) $g(x) = -x^2 + 3$ B) $g(x) = -x^2 - 3$ C) $g(x) = (-x + 3)^2$ D) $g(x) = (-x - 3)^2$

77)

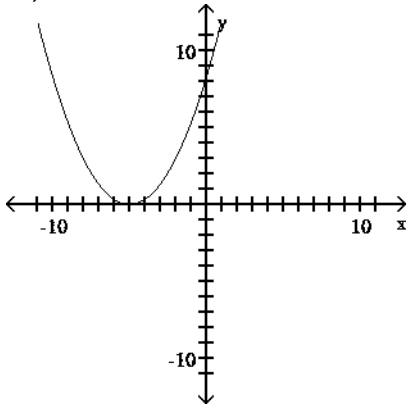

77) _____

- A) $g(x) = \frac{1}{3}(x + 5)^2$ B) $g(x) = \frac{1}{3}x^2 + 5$ C) $g(x) = (x - 5)^2$ D) $g(x) = \frac{1}{3}x^2 - 5$

78)

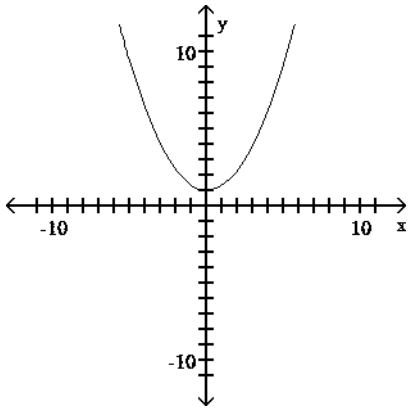

78) _____

- A) $g(x) = \frac{1}{3}(x - 3)^2$ B) $g(x) = \frac{1}{3}(x + 3)^2$ C) $g(x) = -x^2 - 3$ D) $g(x) = \frac{1}{3}(x + 3)^2$

79)

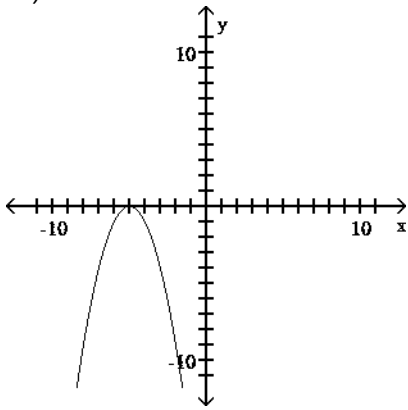

79) _____

- A) $g(x) = -x^2 - 5$ B) $g(x) = -(x + 5)^2$ C) $g(x) = -x^2$ D) $g(x) = -x^2 + 5$

Provide an appropriate response.

80) True or false? If r is an x -intercept of the graph of $y = f(x)$, then $y = -f(x)$ has an x -intercept at $x = -r$. 80) _____
 A) True B) False

81) True or false? If b is a y -intercept of the graph of $y = f(x)$, then $y = -f(x)$ has a y -intercept at $x = -b$. 81) _____
 A) False B) True

82) True or false? If the function $y = f(x)$ decreases on the interval (a, b) of its domain, then $y = f(-x)$ increases on the interval (a, b) . 82) _____

- A) False B) True

83) If b is a y -intercept of the graph of $y = f(x)$, then $y = 4f(x)$ has a **y -intercept** of which of these points? 83) _____
 A) $-4b$ B) b C) $4b$ D) $-b$

84) True or false? If the function $y = f(x)$ decreases on the interval (a, b) of its domain, and we are given that $c < 0$, then the graph of $y = cf(x)$ decreases on the interval (a, b) . 84) _____

- A) True B) False

85) True or False. If the graph of $y = f(x)$ is symmetric with respect to the y -axis, then the graph of $y = f(-x)$ is not symmetric with respect to the y -axis. 85) _____

A) True B) False

86) True or False. If the graph of $y = f(x)$ is symmetric with respect to the origin, then the graph of $y = -f(x)$ is symmetric with respect to the origin. 86) _____

A) False B) True

- 1) C
- 2) A
- 3) D
- 4) D
- 5) D
- 6) C
- 7) A
- 8) B
- 9) D
- 10) A
- 11) B
- 12) B
- 13) D
- 14) D
- 15) C
- 16) D
- 17) C
- 18) D
- 19) A
- 20) A
- 21) B
- 22) C
- 23) C
- 24) C
- 25) D
- 26) C
- 27) A
- 28) C
- 29) B
- 30) C
- 31) C
- 32) A
- 33) D
- 34) D
- 35) A
- 36) C
- 37) A
- 38) D
- 39) C
- 40) B
- 41) B
- 42) A
- 43) A
- 44) A
- 45) A
- 46) B
- 47) B
- 48) D
- 49) D
- 50) C
- 51) A

- 52) C
- 53) A
- 54) D
- 55) B
- 56) C
- 57) B
- 58) B
- 59) D
- 60) B
- 61) A
- 62) C
- 63) D
- 64) B
- 65) A
- 66) D
- 67) B
- 68) A
- 69) D
- 70) D
- 71) B
- 72) B
- 73) D
- 74) A
- 75) C
- 76) C
- 77) A
- 78) B
- 79) B
- 80) B
- 81) B
- 82) B
- 83) C
- 84) B
- 85) B
- 86) B

Exam
Name _____

MULTIPLE CHOICE. Choose the one alternative that best completes the statement or answers the question.
The graph of the function $y = f(x)$ is given below. Sketch the graph of $y = |f(x)|$.

1)

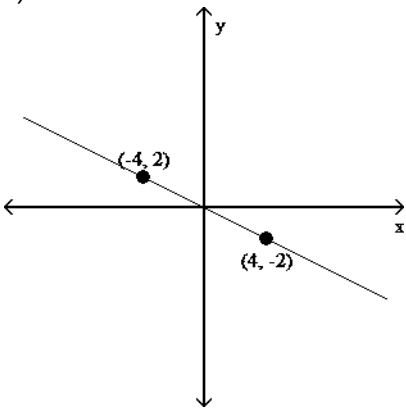

1) _____

A)

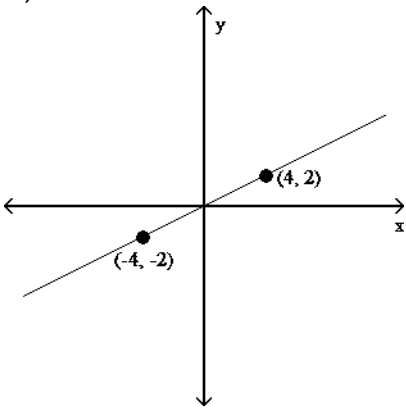

B)

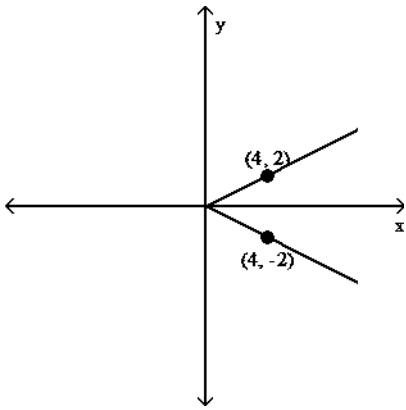

C)

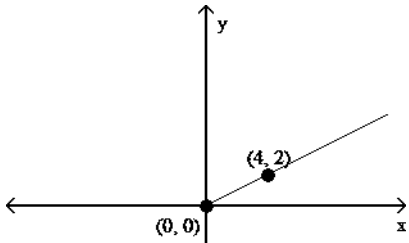

D)

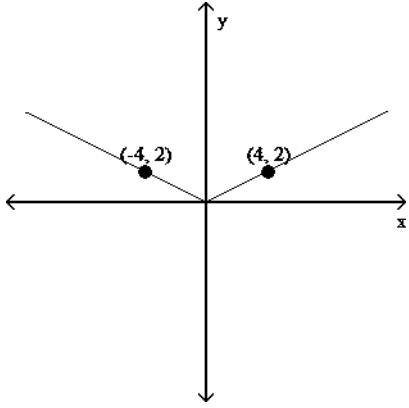

2)

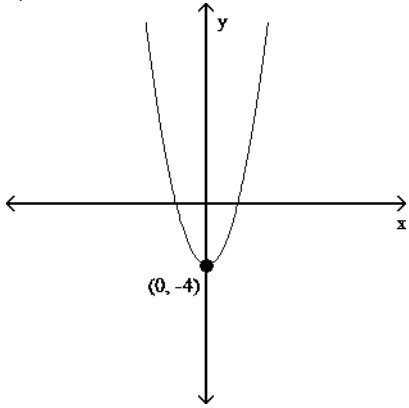

2) _____

A)

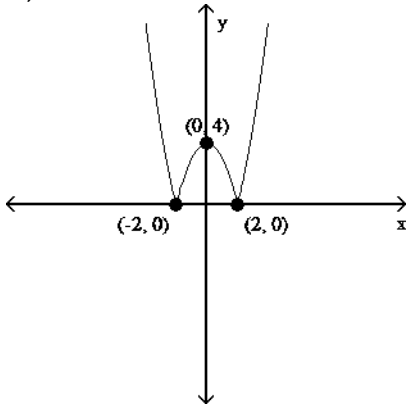

B)

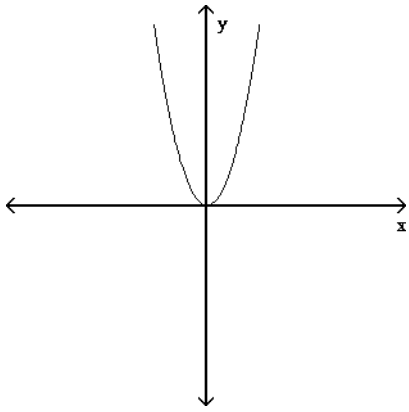

C)

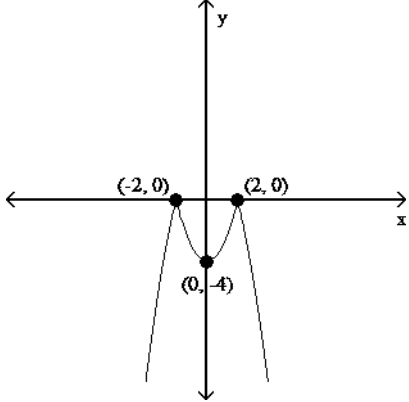
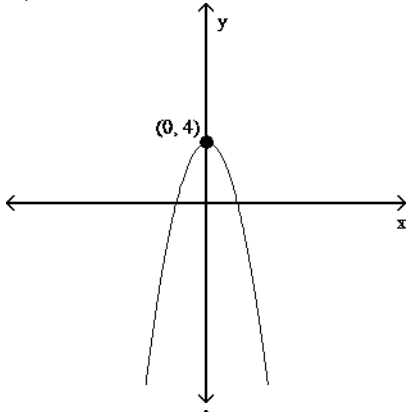

D)

3)

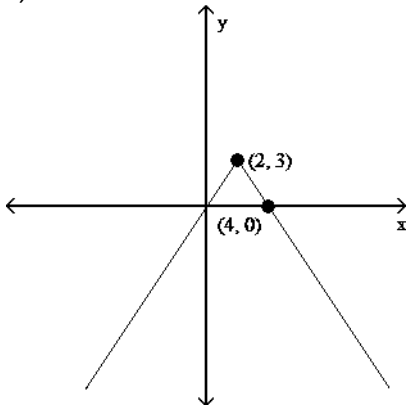

3) _____

A)

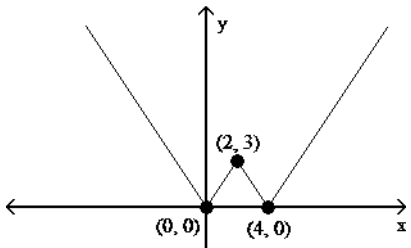

B)

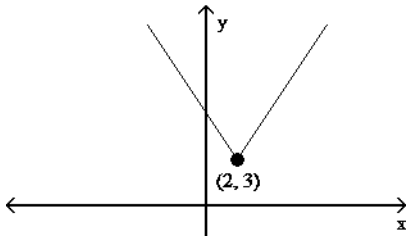

C)

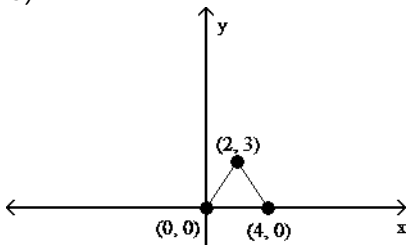

D)

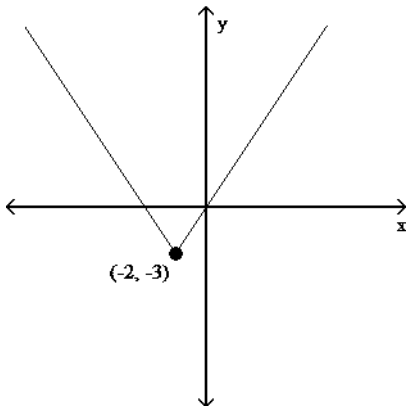

4)

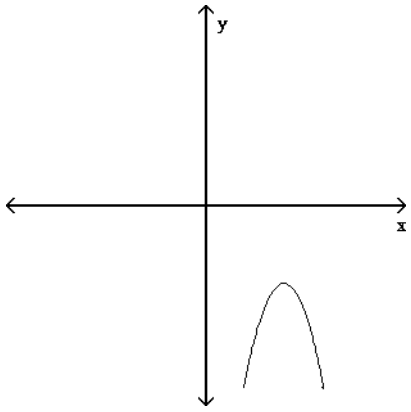

4) _____

A)

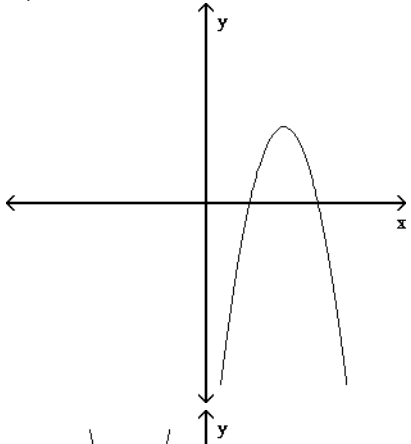

B)

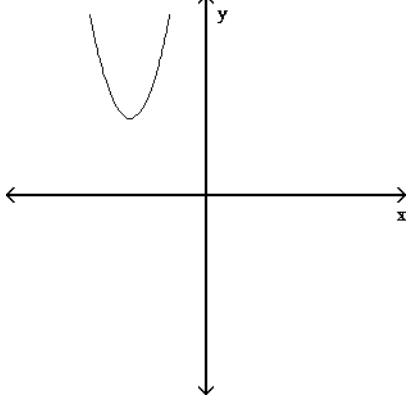

C)

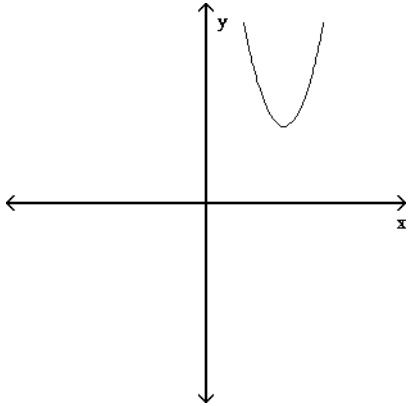

D)

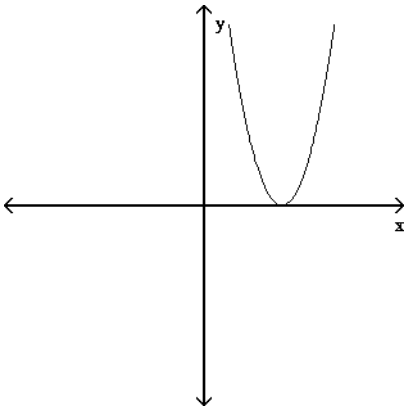

5)

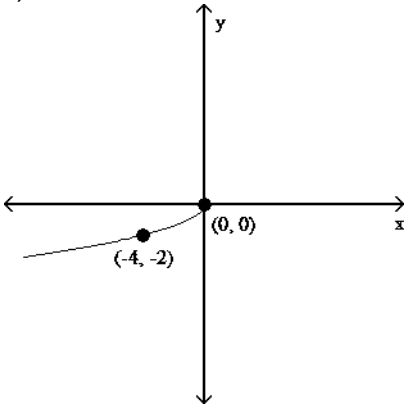

5) _____

A)

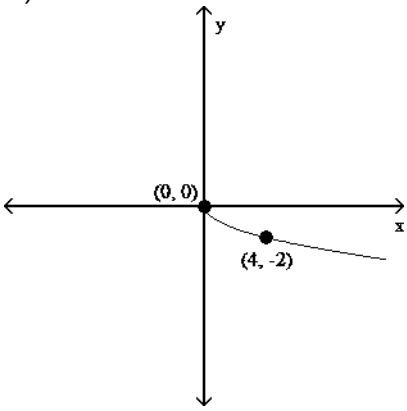

B)

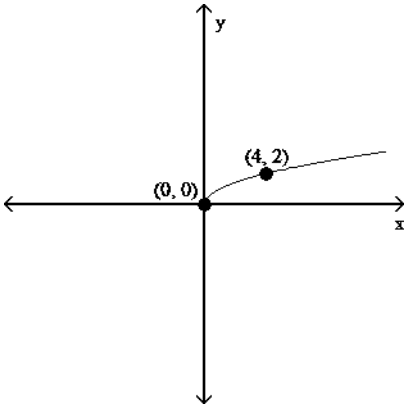

C)

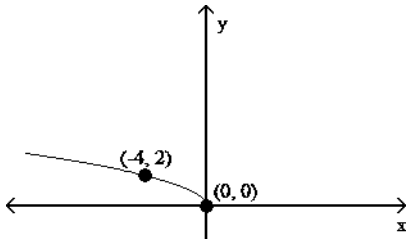

D)

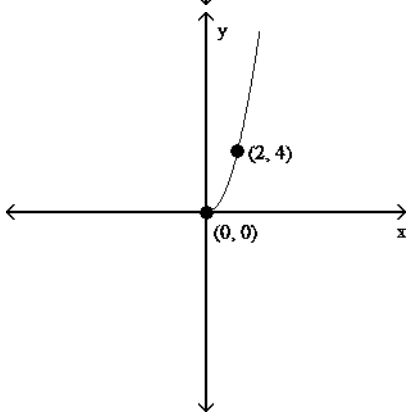

6)

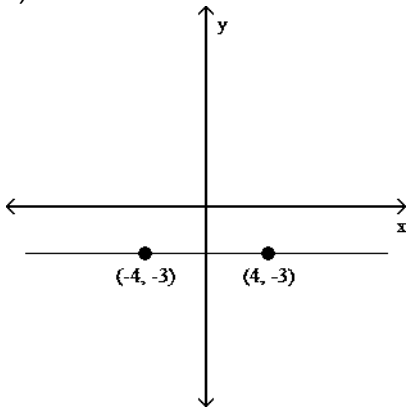

6) _____

A)

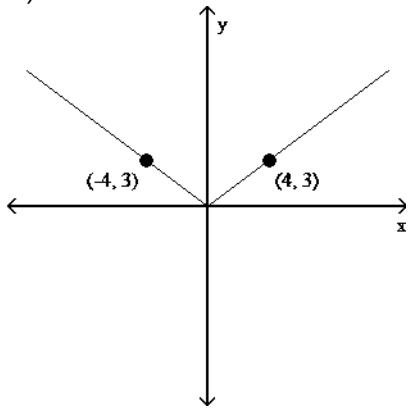

B)

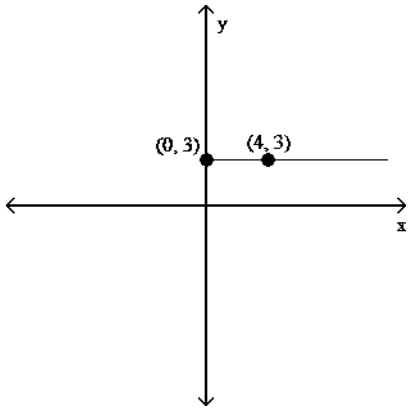

C)

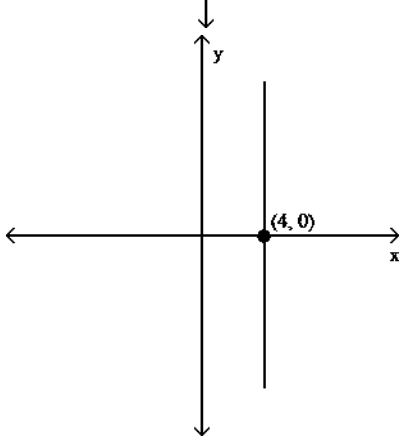
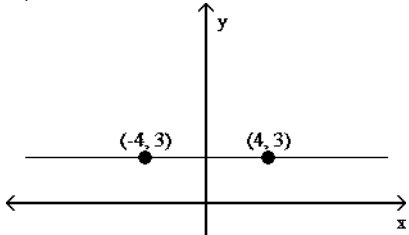

D)

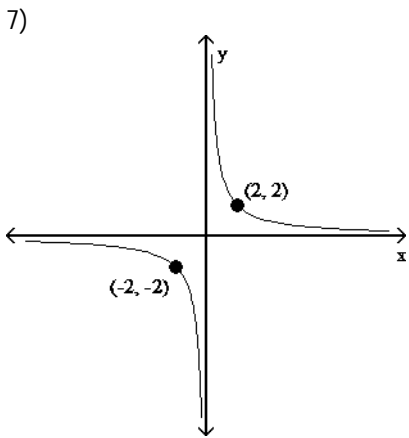

7) _____

A)

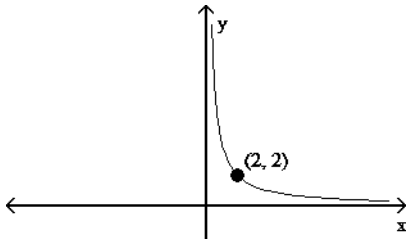

B)

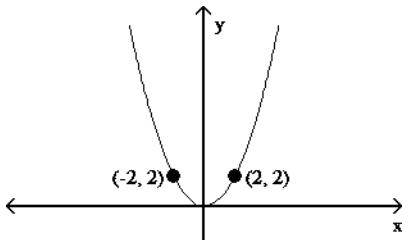

C)

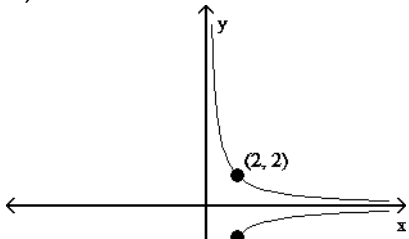

D)

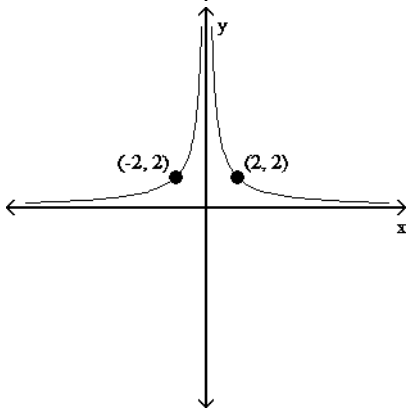

8)

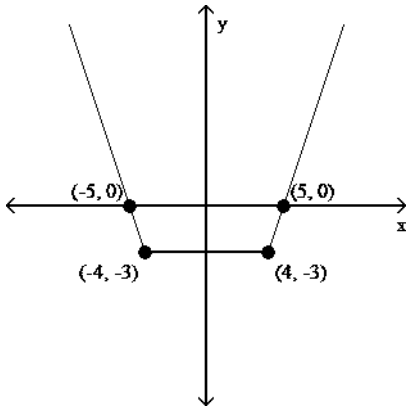

8) _____

A)

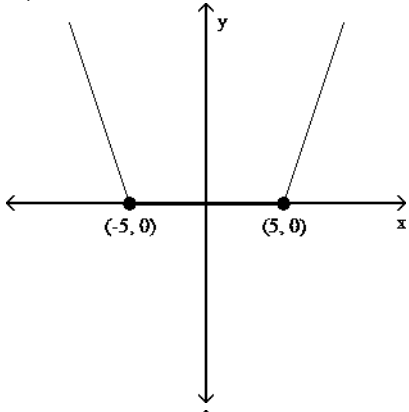

B)

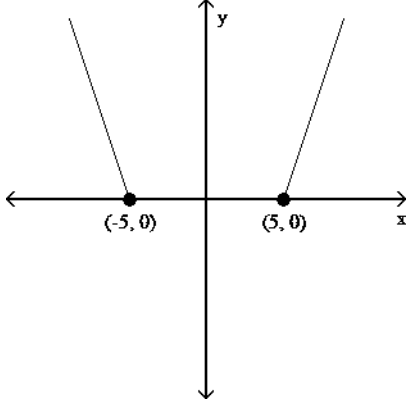

C)

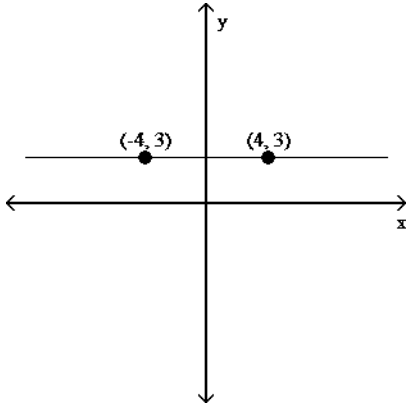

D)

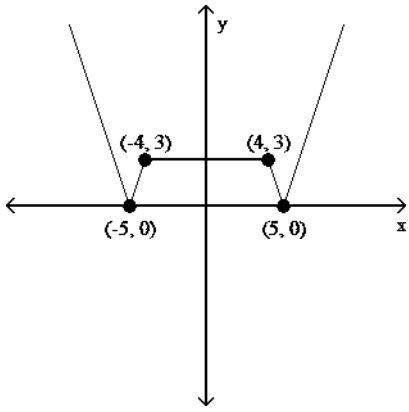

9)

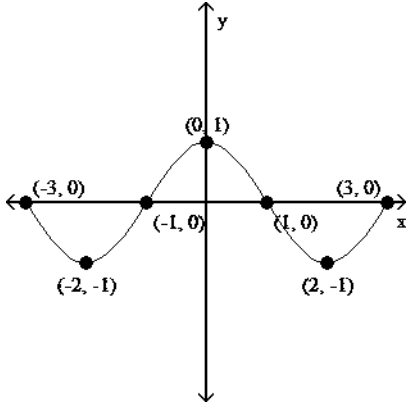

9) _____

A)

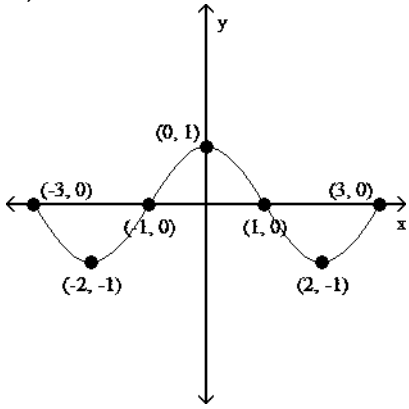

B)

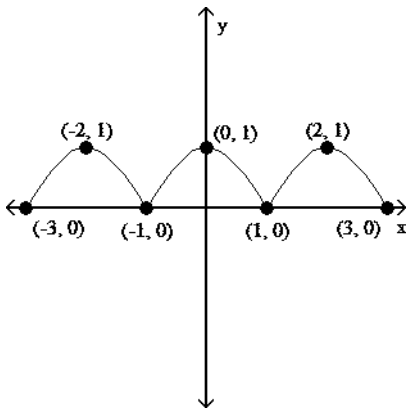

C)

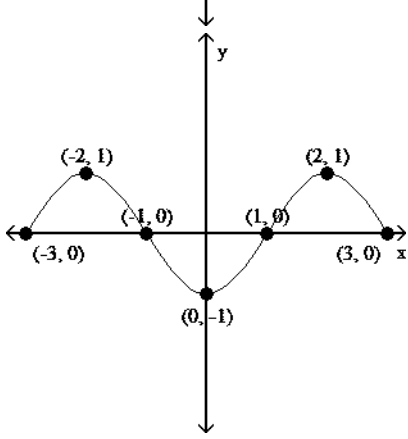
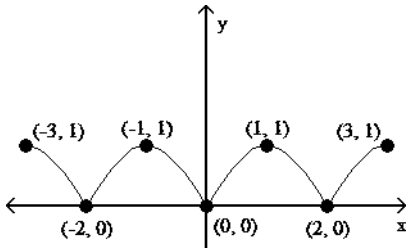

D)

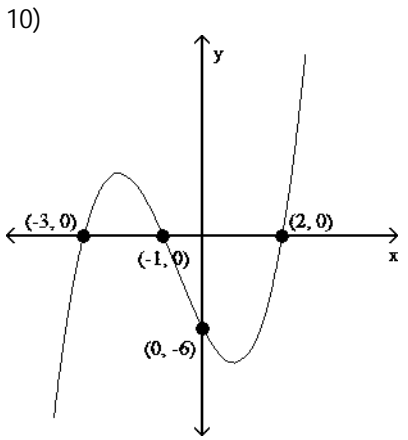

10) _____

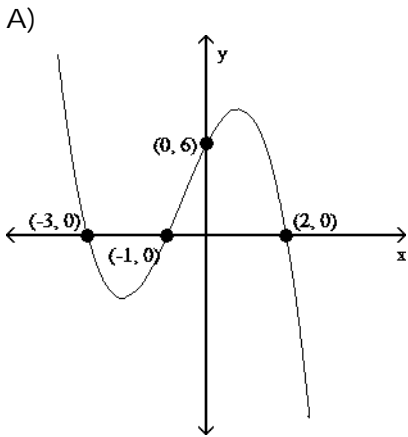

B)

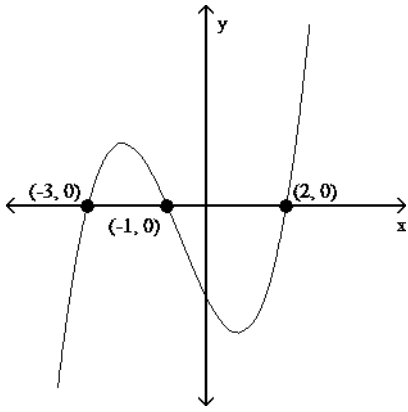

C)

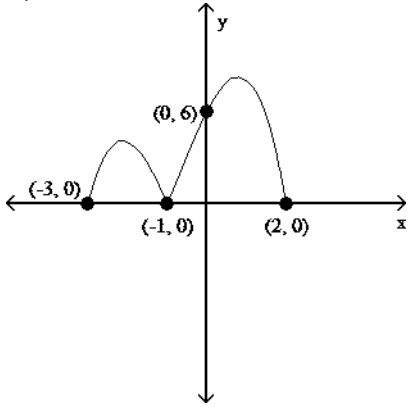

D)

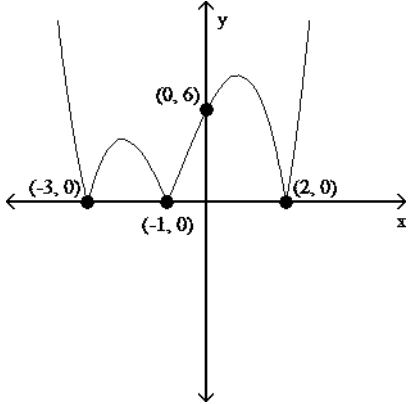

Provide an appropriate response.

11) If the range of $y = f(x)$ is $(-\infty, \infty)$, what is the range of $y = |f(x)|$? 11) _____

- A) $(0, \infty)$ B) $[0, \infty)$ C) $(-\infty, 0]$ D) $(-\infty, \infty)$

12) If the range of $y = f(x)$ is $(-\infty, 0]$, what is the range of $y = |f(x)|$? 12) _____

- A) $[0, \infty)$ B) $(-\infty, 0]$ C) $(0, \infty)$ D) $(-\infty, \infty)$

13) If the range of $y = f(x)$ is $[8.9, \infty)$, what is the range of $y = |f(x)|$? 13) _____

- A) $[0, \infty)$ B) $(-\infty, \infty)$ C) $[8.9, \infty)$ D) $(-\infty, 8.9]$

14) If the range of $y = f(x)$ is $[-17.4, \infty)$, what is the range of $y = |f(x)|$? 14) _____

- A) $[17.4, \infty)$ B) $(-\infty, -17.4]$ C) $(-\infty, 0]$ D) $[0, \infty)$

15) If the range of $y = f(x)$ is $(-\infty, 11.8)$, what is the range of $y = |f(x)|$? 15) _____

- A) $[0, \infty)$ B) $(-\infty, -11.8]$ C) $(-\infty, \infty)$ D) $[11.8, \infty)$

16) If the range of $y = f(x)$ is $(-\infty, -4.2]$, what is the range of $y = |f(x)|$? 16) _____
 A) $[-4.2, \infty)$ B) $(-\infty, 4.2]$ C) $[4.2, \infty)$ D) $[0, \infty)$

Use the graph, along with the indicated points, to give the solution set of the equation or inequality.

17) $y_1 = y_2$

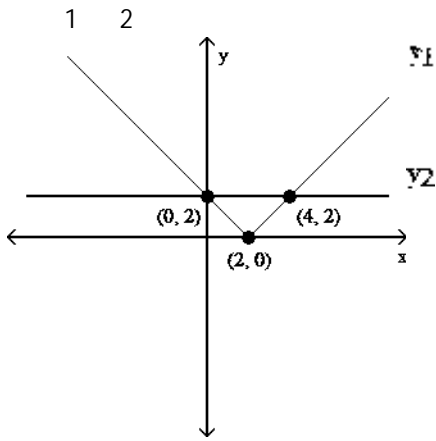

17) _____

A) $\{2\}$ B) $(0, 4)$ C) $[0, 4]$ D) $\{0, 4\}$

18) $y_1 > y_2$

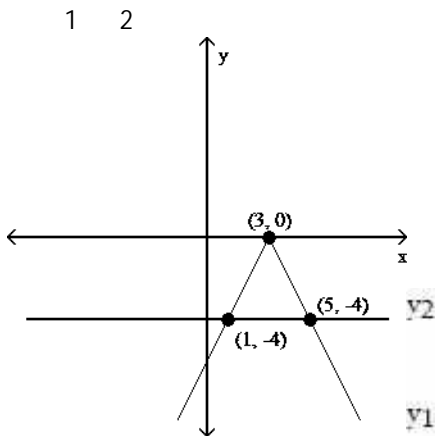

18) _____

A) $[1, 5]$ B) $(-\infty, 1) \cup (5, \infty)$ C) $(-\infty, 1] \cup [5, \infty)$ D) $(1, 5)$

19) $y_1 = y_2$

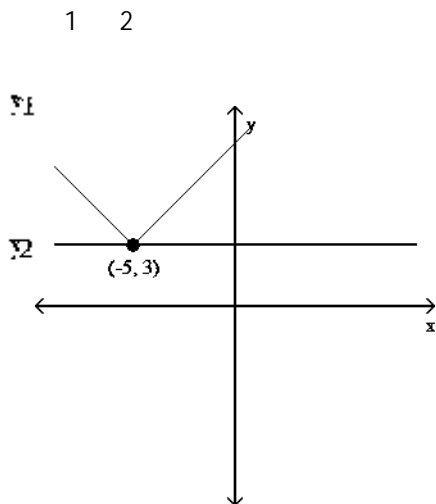

19) _____

- A) $(-\infty, -5]$ B) $(-5, 3)$ C) $\{-5\}$ D) $\{3\}$

20) $y_1 \leq y_2$

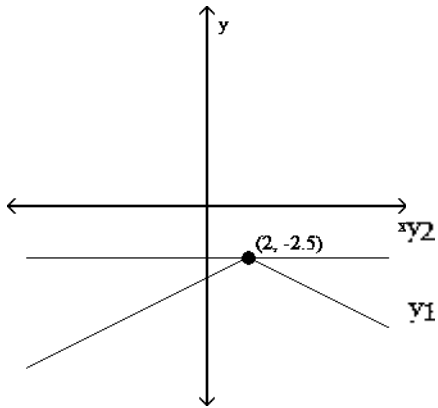

20) _____

- A) $\{2\}$ B) $(-\infty, 2)$ C) $(-\infty, 2]$ D) $(-\infty, \infty)$

21) $y_1 \geq y_2$

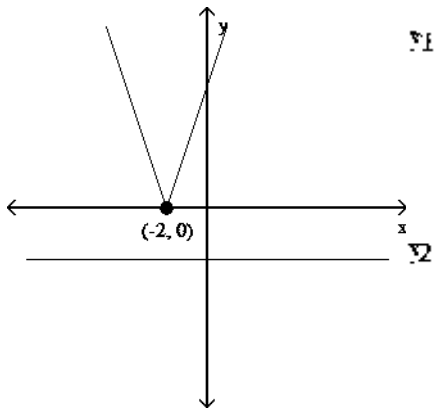

21) _____

- A) $(-\infty, \infty)$ B) $(-2, \infty)$ C) \emptyset D) $[-2, \infty)$

22) $y_1 \geq y_2$

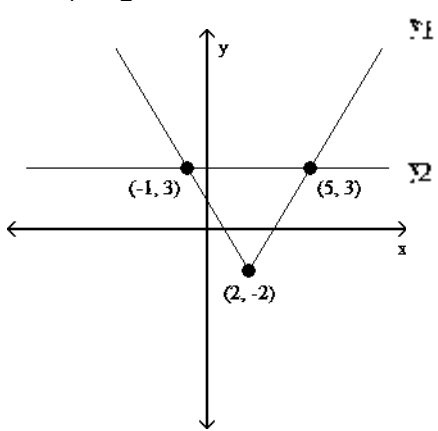

22) _____

- A) $(-1, 5)$ B) $(-\infty, 1) \cup (5, \infty)$ C) $[-1, 5]$ D) $(-\infty, -1] \cup [5, \infty)$

Solve the equation.

23) $|x - 5| = 0$ 23) _____

- A) {5} B) $(-\infty, 5)$ C) $\{-5, 5\}$ D) $(-5, \infty)$

24) $|8x + 2| = 7$ 24) _____

- A) $\left\{\frac{5}{8}, -\frac{9}{8}\right\}$ B) $\left\{-\frac{9}{8}, -\frac{5}{8}\right\}$ C) $\left\{\frac{9}{8}, -\frac{5}{8}\right\}$ D) $\left\{\frac{5}{8}\right\}$

25) $|4x - 5| = 20$ 25) _____

- A) $\left\{-\frac{15}{4}, \frac{25}{4}\right\}$ B) $\left\{-\frac{25}{4}\right\}$ C) $\left\{\frac{25}{4}, -\frac{25}{4}\right\}$ D) $\left\{-\frac{25}{4}, \frac{15}{4}\right\}$

26) $|x + 8.7| = 2$ 26) _____

- A) $\{-6.7, -10.7\}$ B) $\{6.7\}$ C) $\{-6.7, 10.7\}$ D) \emptyset

27) $|x - 1| + 2 = 5$ 27) _____

- A) $\{4, -2\}$ B) $\{4\}$ C) $\{-4, 2\}$ D) \emptyset

28) $|2x + 5| + 3 = 11$ 28) _____

- A) $\left\{\frac{3}{5}, -\frac{13}{5}\right\}$ B) $\left\{-\frac{3}{2}, \frac{13}{2}\right\}$ C) $\left\{\frac{3}{2}, -\frac{13}{2}\right\}$ D) \emptyset

29) $|2x - 3| - 4 = 5$ 29) _____

- A) $\langle -6, 3 \rangle$ B) $\langle -4, 2 \rangle$ C) $\langle 6, -3 \rangle$ D) \emptyset

30) $|6x + 8| - 1 = -6$ 30) _____

- A) $\left\{-\frac{1}{2}, \frac{13}{6}\right\}$ B) $\left\{-\frac{13}{6}\right\}$ C) $\left\{\frac{1}{2}, -\frac{13}{6}\right\}$ D) \emptyset

31) $2|x + 4| - 10 = 2$ 31) _____

- A) $\langle -10 \rangle$ B) $\langle 2, 8 \rangle$ C) $\langle 2, -10 \rangle$ D) $\langle 2 \rangle$

32) $|2(x - 1) + 3| + 5 = 10$ 32) _____

- A) $\{-3, 2\}$ B) $\left\{-\frac{7}{2}\right\}$ C) $\left\{-\frac{7}{2}, \frac{3}{2}\right\}$ D) \emptyset

Solve the inequality.

33) $|x - 4| > 2$ 33) _____

- A) $(2, 6)$ B) $(6, \infty)$ C) $(-\infty, 2) \cup (6, \infty)$ D) \emptyset

34) $|9 + 8x| > 2$ 34) _____

- A) $\left(-\frac{7}{8}, \frac{11}{8}\right)$ B) $\left(-\infty, -\frac{11}{8}\right) \cup \left(-\frac{7}{8}, \infty\right)$
C) $\left(-\infty, \frac{9}{8}\right) \cup \left(\frac{13}{8}, \infty\right)$ D) $\left(-\frac{11}{8}, -\frac{7}{8}\right)$

35) $|5 - 5x| > 6$ 35) _____

A) $\left(-\frac{11}{5}, -\frac{1}{5}\right)$ B) $\left(-\infty, -\frac{1}{5}\right) \cup \left(-\frac{13}{5}, \infty\right)$
 C) $\left(-\infty, -\frac{1}{5}\right) \cup \left(\frac{11}{5}, \infty\right)$ D) $\left(\frac{1}{5}, -\frac{11}{5}\right)$

36) $|2 - 3x| \leq 11$ 36) _____
 A) $\left[-\frac{13}{3}, 3\right]$ B) $(-\infty, 3] \cup \left[\frac{13}{3}, \infty\right)$
 C) $(-\infty, -3] \cup \left[\frac{13}{3}, \infty\right)$ D) $\left[-3, \frac{13}{3}\right]$

37) $|5 - x| \leq 9$ 37) _____
 A) $(-\infty, -4] \cup [14, \infty)$ B) $[14, \infty)$ C) $[-4, \infty)$ D) $[-4, 14]$

38) $|4x - 4| - 8 < -2$ 38) _____
 A) $\left(-\infty, -\frac{1}{2}\right) \cup \left(\frac{5}{2}, \infty\right)$ B) $\left(-\infty, -\frac{1}{2}\right)$
 C) $\left(\frac{1}{2}, \frac{5}{2}\right)$ D) \emptyset

39) $|x + 9| + 2 > 18$ 39) _____
 A) $(-\infty, -25) \cup (7, \infty)$ B) $(-25, 7)$
 C) $(-\infty, -25) \cup (11, \infty)$ D) $(-\infty, -11) \cup (25, \infty)$

40) $|9x - 2| > -9$ 40) _____
 A) $\left(-\infty, \frac{7}{9}\right)$ B) $\left(-\frac{11}{9}, \frac{7}{9}\right)$ C) $(-\infty, \infty)$ D) \emptyset

41) $|x + 2| \leq 0$ 41) _____
 A) $\{2\}$ B) $\{-2\}$ C) $(-\infty, -2)$ D) \emptyset

42) $|x - 1| < 0$ 42) _____
 A) $\{1\}$ B) $(-\infty, 1)$ C) $\{-1\}$ D) \emptyset

Solve the equation.

43) $|5x + 6| = |6x + 7|$ 43) _____
 A) $\left\{-\frac{13}{1}, 1\right\}$ B) $\{13, 1\}$ C) $\left\{-1, -\frac{13}{11}\right\}$ D) $\left\{\frac{1}{11}, 13\right\}$

44) $|5x - 8| = |4x - 7|$ 44) _____
 A) $\left\{1, \frac{5}{3}\right\}$ B) $\left\{\frac{1}{9}, 15\right\}$ C) $\{15, 1\}$ D) $\{-15, 1\}$

45) $|7x + 8| = |7 - 6x|$ 45) _____
 A) $\left\{\frac{15}{13}, 1\right\}$ B) $\left\{-\frac{15}{13}, 1\right\}$ C) $\left\{-\frac{1}{13}, -15\right\}$ D) $\left\{-1, -\frac{15}{13}\right\}$

46) $|-10+9x| = |1-4x|$ 46) _____
 A) $\left\{-\frac{9}{13}, 1\right\}$ B) $\left\{\frac{11}{13}, \frac{9}{5}\right\}$ C) $\left\{\frac{11}{5}, \frac{9}{13}\right\}$ D) $\left\{\frac{9}{13}, 1\right\}$

47) $|4x-8| = |x-3|$ 47) _____
 A) $\left\{\frac{5}{3}, \frac{11}{5}\right\}$ B) $\frac{5}{3}$ C) $\left\{-\frac{5}{3}, -\frac{11}{5}\right\}$ D) \emptyset

48) $|2x+2| = |x-8|$ 48) _____
 A) $\langle -10, 2 \rangle$ B) $\langle -10 \rangle$ C) $\langle 10, -2 \rangle$ D) \emptyset

49) $|2x-9| = |x-8|$ 49) _____
 A) $\langle -1, -17 \rangle$ B) $\langle 1, -10 \rangle$ C) $\left\{1, \frac{17}{3}\right\}$ D) \emptyset

50) $\left|\frac{1}{2}x+2\right| = \left|\frac{3}{4}x-2\right|$ 50) _____
 A) $\{10, 10\}$ B) $\{16, 0\}$ C) $\{16, 12\}$ D) \emptyset

51) $|2x+5| = |2x-6|$ 51) _____
 A) $\left\{0, -\frac{11}{4}\right\}$ B) $\left\{\frac{1}{4}\right\}$ C) $\left\{0, \frac{1}{4}\right\}$ D) \emptyset

Solve the inequality graphically.

52) $|3x+9| > |x-1|$ 52) _____
 A) $(-\infty, -5) \cup (-2, \infty)$ B) $(2, 5)$ C) $(-5, -2)$ D) \emptyset

53) $|3x+9| < |x-1|$ 53) _____
 A) $(-\infty, -5) \cup (-2, \infty)$ B) $(-5, -2)$ C) $(2, 5)$ D) \emptyset

54) $\left|\frac{1}{2}x+2\right| > \left|\frac{3}{4}x-2\right|$ 54) _____
 A) $(16, \infty)$ B) $(0, 16)$ C) $(-\infty, 16)$ D) $(-\infty, 0) \cup (16, \infty)$

55) $\left|\frac{1}{2}x+2\right| < \left|\frac{3}{4}x-2\right|$ 55) _____
 A) $(-\infty, 16)$ B) $(-\infty, 0) \cup (16, \infty)$ C) $(16, \infty)$ D) $(0, 16)$

Solve the equation or inequality graphically. Express solutions or endpoints of intervals rounded to the nearest hundredth, if necessary.

56) $|7x-11| = \sqrt{x+6}$ 56) _____
 A) $\{-1.97, 1.19\}$ B) $\{1.97, 1.19\}$ C) $\{-1.97, -1.19\}$ D) $\{1.97, 1.97\}$

57) $|3x-5| = 6x-2$ 57) _____
 A) $\{1\}$ B) $\{0.78\}$ C) \emptyset D) $\{-0.78\}$

58) $|-7x - 9| \geq -x - 7$ 58) _____
 A) $(-\infty, 0.25] \cup [2.67, \infty)$ B) $[-0.25, -2.67]$
 C) $[0.25, 2.67]$ D) $(-\infty, -2.67] \cup [-0.25, \infty)$

59) $|x + 3| > .4x - 5$ 59) _____
 A) \emptyset B) $[-3, 1.25]$
 C) $(-\infty, -3] \cup [1.25, \infty)$ D) $(-\infty, \infty)$

60) $|3x + 7| < -|3x - 4|$ 60) _____
 A) $[2.33, 0.57]$ B) \emptyset
 C) $(-\infty, 2.33] \cup [0.57, \infty)$ D) $(-\infty, \infty)$

61) $|x + \sqrt{7}| + \sqrt{5} \leq -x - \sqrt{11}$
 (Provide exact answer.) 61) _____

A) $(-\infty, -\sqrt{5}] \cup [\sqrt{5}, \infty)$ B) \emptyset
 C) $(-\infty, \infty)$ D) $(-\infty, -\sqrt{11}] \cup [\sqrt{11}, \infty)$

62) $|x| + |x - 10| = 20$ 62) _____
 A) $\{-5\}$ B) $\{-5, 15\}$ C) $\{5, 15\}$ D) \emptyset

63) $|x + 4| + |x - 8| = 16$ 63) _____
 A) $\{10\}$ B) $\{-10, 6\}$ C) $\{10, -6\}$ D) \emptyset

Solve the problem.

$$F = \frac{9}{5}C + 32$$

64) The formula to find Fahrenheit temperature, F, given Celsius temperature, C, is $F = \frac{9}{5}C + 32$. Find the range, in Fahrenheit, when the temperature in Celsius is between 2°C and 8°C , inclusive. Round to the nearest tenth. 64)

- _____
- A) $33.1^\circ\text{F} \leq \text{Temperature} \leq 46.4^\circ\text{F}$ B) $3.6^\circ\text{F} \leq \text{Temperature} \leq 14.4^\circ\text{F}$
 C) $35.6^\circ\text{F} \leq \text{Temperature} \leq 46.4^\circ\text{F}$ D) $19.6^\circ\text{F} \leq \text{Temperature} \leq 30.4^\circ\text{F}$

$$C = \frac{5}{9}(F - 32)$$

65) The formula to find Celsius temperature, C, given Fahrenheit temperature, F, is $C = \frac{5}{9}(F - 32)$. If the processing temperature of a chemical ranges from 302°F to 347°F , inclusive, then what is the range of its temperature in degrees Celsius? 65) _____

- A) $32^\circ\text{C} \leq \text{Temperature} \leq 45^\circ\text{C}$ B) $270^\circ\text{C} \leq \text{Temperature} \leq 315^\circ\text{C}$
 C) $100^\circ\text{C} \leq \text{Temperature} \leq 175^\circ\text{C}$ D) $150^\circ\text{C} \leq \text{Temperature} \leq 175^\circ\text{C}$

66) The temperature on the surface of the planet Krypton in degrees Celsius satisfies the inequality $|C + 55| \leq 17$. What range of temperatures corresponds to this inequality? (Use interval notation.) 66) _____

- A) $[38, 72]$ B) $[-72, 38]$ C) $[-38, 72]$ D) $[-72, -38]$

67) Dr. Hughes found that the weight, w, of 99% of his students at Cantanople University satisfied the inequality $|w - 152| < 59$. What range of weights corresponds to this inequality? (Use interval notation.) 67) _____

- A) (93, 211) B) $(-\infty, 93) \cup (211, \infty)$
 C) $(-\infty, 93] \cup [211, \infty)$ D) [93, 211]

68) The Fahrenheit temperature, F , in Siber City in October ranges from 62°F to 38°F . Write an absolute value inequality whose solution is this range. 68) _____

- A) $|F - 50| < 12$ B) $|F| < 62$ C) $|F - 12| < 50$ D) $|F| > 38$

69) In a milling operation, the thickness of the formica sheets that can be produced satisfies the inequality $|x - 1.85| \leq 1.26$. What range of thicknesses corresponds to this inequality? 69) _____

- A) [0.59, 6.22] B) [0.59, 3.11] C) [0.3, 3.11] D) [1.26, 1.85]

70) The average annual growth rate of a coral reef in inches satisfies the inequality $|x - 3.46| \leq 2.29$. What range of growth corresponds to this inequality? 70) _____

- A) [1.17, 5.75] B) [2.29, 3.46] C) [0.59, 5.75] D) [1.17, 11.5]

71) The number of non-text books read by college students ranges from 10 to 56. Using B as the variable, write an absolute value inequality that corresponds to this range. 71) _____

- A) $|B - 46| \leq 10$ B) $|B - 23| \leq 33$ C) $|B - 33| \leq 23$ D) $|B - 10| \leq 46$

72) A real estate development consists of home sites that range in width from 51 to 111 feet and in depth from 140 to 180 feet. Using x as the variable in both cases, write absolute value inequalities that correspond to these ranges. 72) _____

- A) $|x - 60| \leq 51$, $|x - 40| \leq 140$ B) $|x - 51| \leq 60$, $|x - 140| \leq 40$
 C) $|x - 30| \leq 81$, $|x - 20| \leq 160$ D) $|x - 81| \leq 30$, $|x - 160| \leq 20$

73) The inequality $|T - 51| \leq 17$ describes the range of monthly average temperatures T in degrees Fahrenheit at a City X. (i) Solve the inequality. (ii) If the high and low monthly average temperatures satisfy equality, interpret the inequality. 73) _____

- A) $29 \leq T \leq 73$; The monthly averages are always within 22° of 51°F .
 B) $T \leq 68$; The monthly averages are always less than or equal to 68°F .
 C) $34 \leq T \leq 68$; The monthly averages are always within 17° of 51°F .
 D) $29 \leq T$; The monthly averages are always greater than or equal to 29°F .

Provide an appropriate response.

74) True or false? The graph of $y = |f(x)|$ is the same as that of $y = f(x)$ for values of $f(x)$ that are negative; and for values of $y = f(x)$ that are nonnegative, the graph is reflected across the x -axis. 74) _____

- A) False B) True

75) One of the graphs below is that of $y = f(x)$, and the other is that of $y = |f(x)|$. State which is the graph of $y = |f(x)|$.

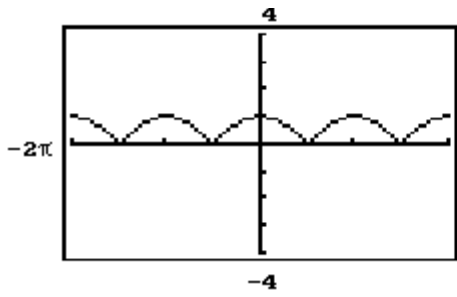

i

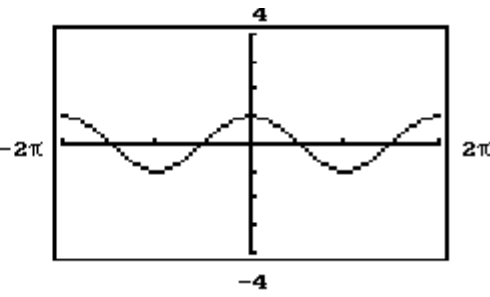

ii 75) _____

A) ii B) i

76) One of the graphs below is that of $y = f(x)$ and the other is that of $y = |f(x)|$. State which is the graph of $y = |f(x)|$.

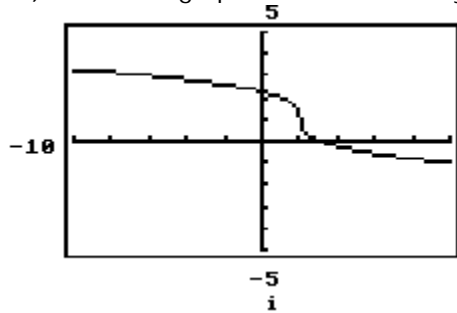

i

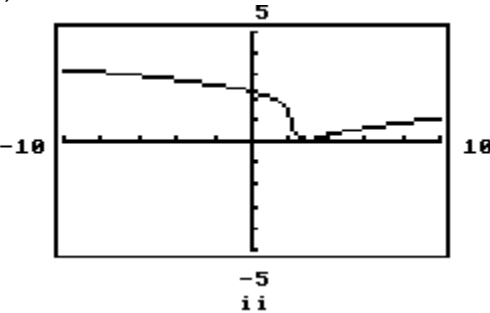

ii

76) _____

A) ii B) i

77) Given $a = 7$, $b = -20$, which of the following statements is false? 77) _____

A) $|a| + |b| \geq -(a+b)$ B) $|ab| = -ab$ C) $|a/b| = a/b$

78) Given $a = -6$, $b = -11$, which of the following statements is false? 78) _____

A) $|a/b| = a/b$ B) $|a| + |b| = -(a+b)$ C) $|ab| = -ab$

79) The graph shown is a translation of the function $y = |x|$ of the form $y = |x - h| + k$. What are the values of h and k ?

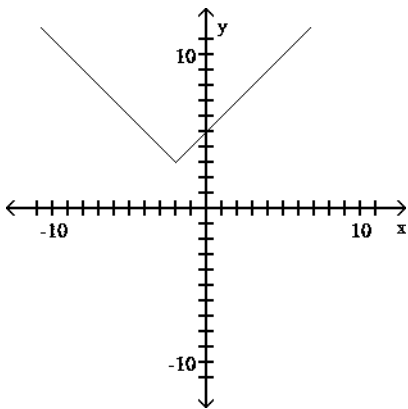

79) _____

A) $h = 2, k = -3$ B) $h = 2, k = 3$ C) $h = -2, k = -3$ D) $h = -2, k = 3$

80) Use graphing to determine the domain and range of $y = |f(x)|$ for $f(x) = -(x - 8)^2 - 7$. 80) _____

A) D: $(-\infty, \infty)$; R: $[7, \infty)$ B) D: $(-\infty, \infty)$; R: $[-7, \infty)$
 C) D: $[0, \infty)$; R: $(-\infty, 7]$ D) D: $[0, \infty)$; R: $(-\infty, -7]$

81) Use graphing to determine the domain and range of $y = |f(x)|$ for $f(x) = |x - 4| - 9$. 81) _____

A) D: $[0, \infty)$; R: $[-9, \infty)$ B) D: $(-\infty, \infty)$; R: $[0, \infty)$

C) D: $(-\infty, \infty)$; R: $[9, \infty)$ D) D: $[0, \infty)$; R: $(-\infty, \infty)$

- 1) D
- 2) A
- 3) A
- 4) C
- 5) C
- 6) C
- 7) D
- 8) D
- 9) B
- 10) D
- 11) B
- 12) A
- 13) C
- 14) D
- 15) A
- 16) C
- 17) D
- 18) D
- 19) C
- 20) D
- 21) A
- 22) D
- 23) A
- 24) A
- 25) D
- 26) A
- 27) A
- 28) C
- 29) C
- 30) D
- 31) C
- 32) A
- 33) C
- 34) B
- 35) C
- 36) D
- 37) D
- 38) C
- 39) A
- 40) C
- 41) B
- 42) D
- 43) C
- 44) A
- 45) C
- 46) B
- 47) A
- 48) A
- 49) C
- 50) B
- 51) B

- 52) A
- 53) B
- 54) B
- 55) B
- 56) B
- 57) B
- 58) C
- 59) D
- 60) B
- 61) B
- 62) B
- 63) C
- 64) C
- 65) D
- 66) D
- 67) A
- 68) A
- 69) B
- 70) A
- 71) C
- 72) D
- 73) C
- 74) A
- 75) B
- 76) A
- 77) C
- 78) C
- 79) D
- 80) A
- 81) B

Exam

Name _____

MULTIPLE CHOICE. Choose the one alternative that best completes the statement or answers the question.
Find the requested value.

1)

$$f(-3) \text{ for } f(x) = \begin{cases} 6x & \text{if } x \leq -1 \\ x - 8 & \text{if } x > -1 \end{cases} \quad 1) \text{ _____}$$

A) 48 B) -16 C) -48 D) 0

2)

$$f(0) \text{ for } f(x) = \begin{cases} x - 7 & \text{if } x < 3 \\ 5 - x & \text{if } x \geq 3 \end{cases} \quad 2) \text{ _____}$$

A) -4 B) 2 C) 5 D) -7

3)

$$f(6) \text{ for } f(x) = \begin{cases} 2x + 7 & \text{if } x \leq 0 \\ 5 - 5x & \text{if } 0 < x < 5 \\ x & \text{if } x \geq 5 \end{cases} \quad 3) \text{ _____}$$

A) 6 B) 19 C) -25 D) 5

4)

$$f(3) \text{ for } f(x) = \begin{cases} 9x + 1 & \text{if } x < 3 \\ 3x & \text{if } 3 \leq x \leq 8 \\ 3 - 5x & \text{if } x > 8 \end{cases} \quad 4) \text{ _____}$$

A) 41 B) -12 C) 9 D) 10

5)

$$f(-2) \text{ for } f(x) = \begin{cases} 6x + 1 & \text{if } x < 2 \\ 2x & \text{if } 2 \leq x \leq 7 \\ 2 - 9x & \text{if } x > 7 \end{cases} \quad 5) \text{ _____}$$

A) 20 B) 13 C) -11 D) -4

Graph the function.

6)

$$f(x) = \begin{cases} 4 & \text{if } x \geq 1 \\ -2 - x & \text{if } x < 1 \end{cases}$$

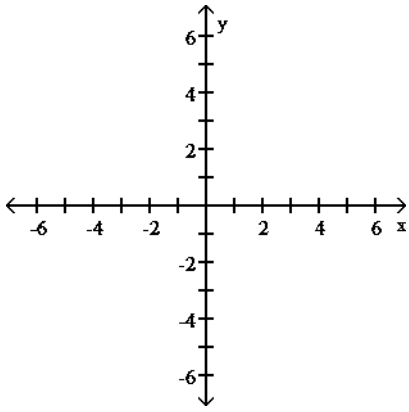

6) _____

A)

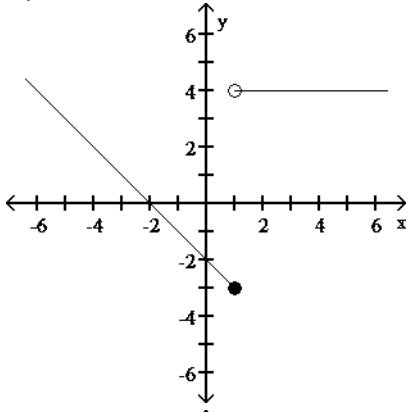

B)

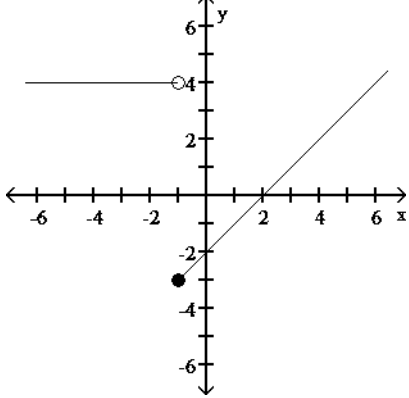

C)

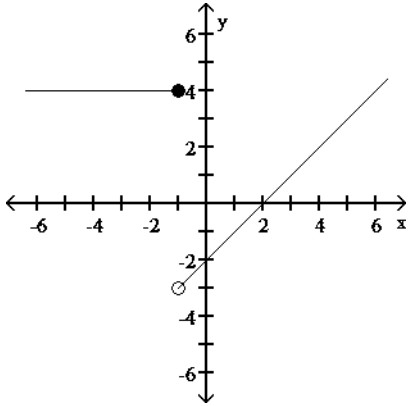

D)

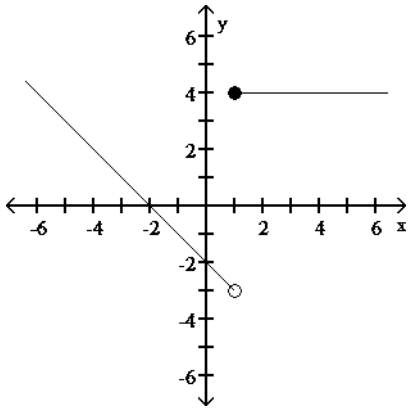

7)

$$f(x) = \begin{cases} x+5 & \text{if } x > 0 \\ -1 & \text{if } x \leq 0 \end{cases}$$

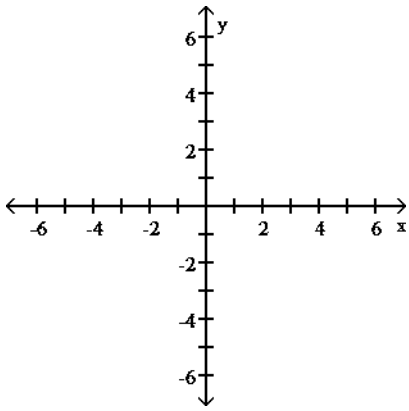

7) _____

A)

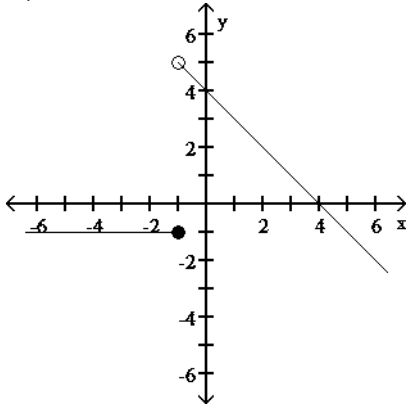

B)

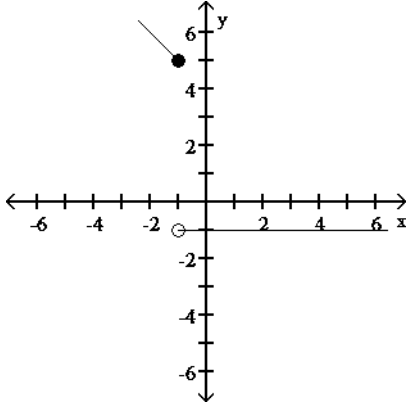

C)

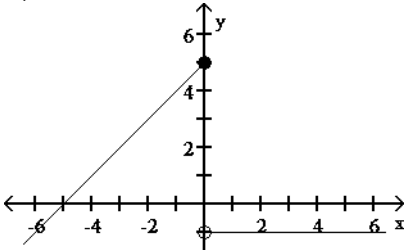

D)

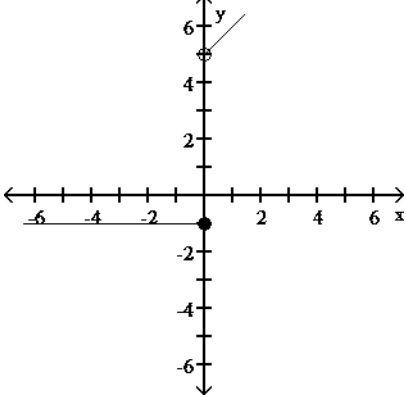

8)

$$f(x) = \begin{cases} 2x + 3 & \text{if } x < 0 \\ 4x^2 - 5 & \text{if } x \geq 0 \end{cases}$$

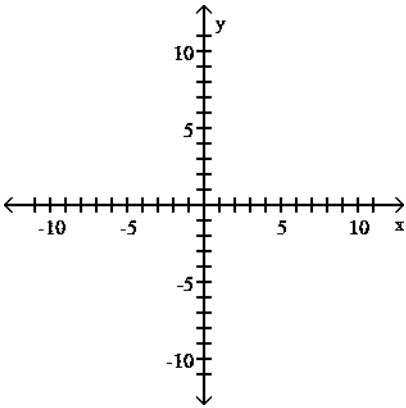

8) _____

A)

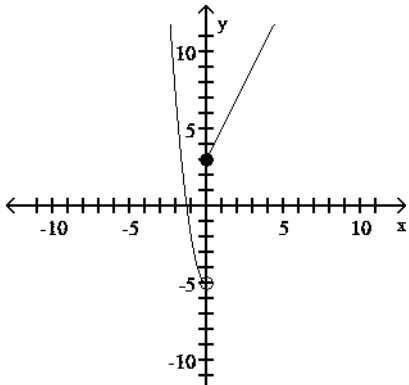

B)

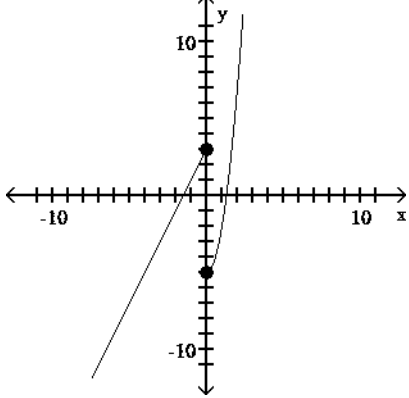

C)

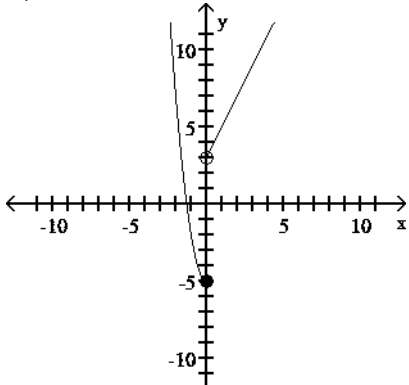

D)

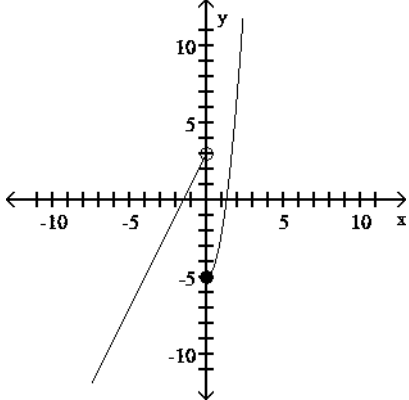

9)

$$f(x) = \begin{cases} x^2 - 9 & \text{if } x < -1 \\ 0 & \text{if } -1 \leq x \leq 1 \\ x^2 + 9 & \text{if } 1 < x \end{cases}$$

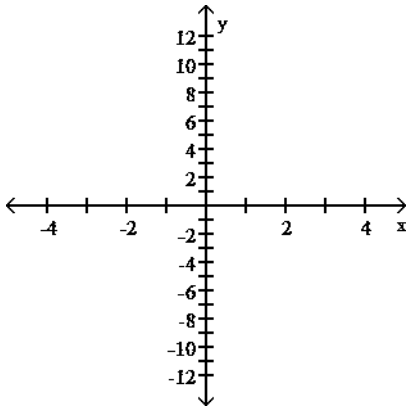

9) _____

A)

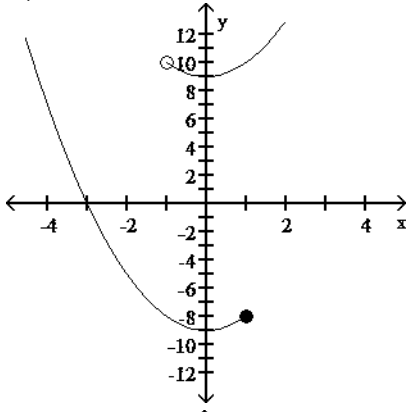

B)

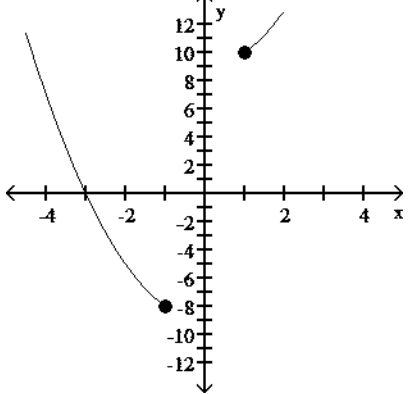

C)

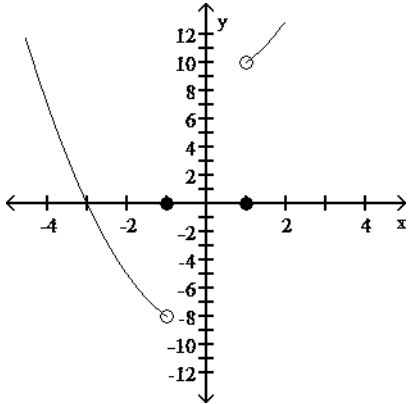

D)

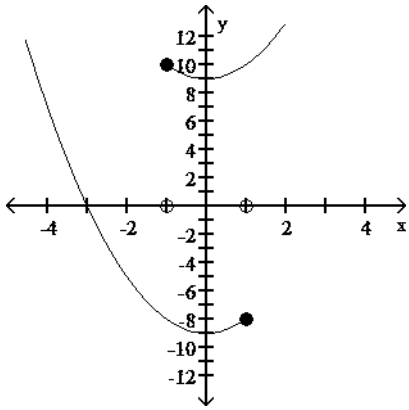

10)

$$f(x) = \begin{cases} |x| + 2 & \text{if } x < 0 \\ 2 & \text{if } x \geq 0 \end{cases}$$

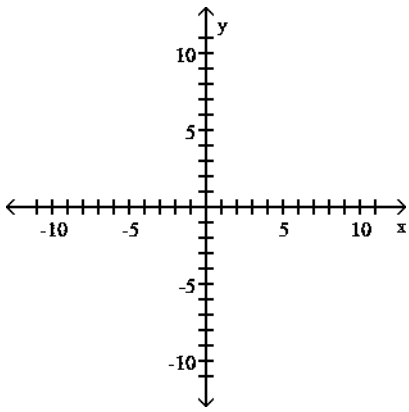

10) _____

A)

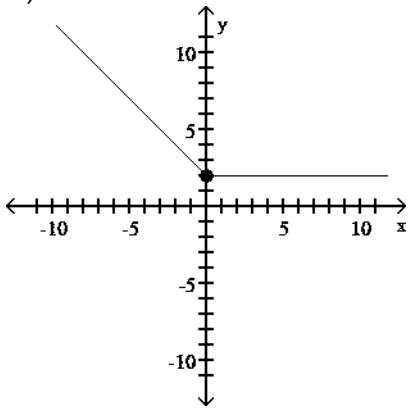

B)

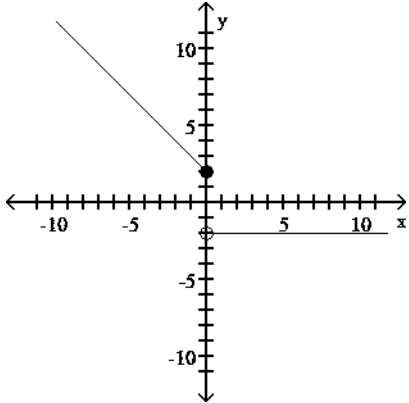

C)

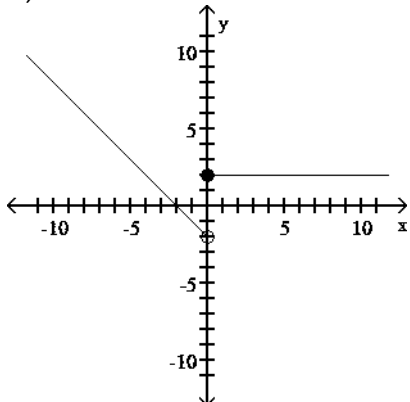

D)

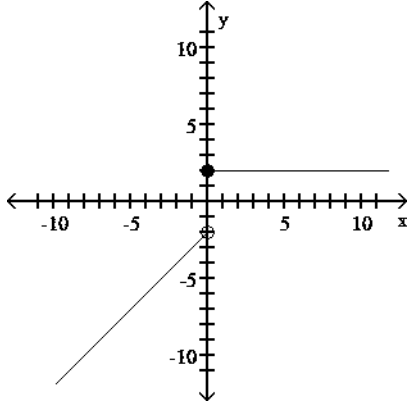

11)

$$f(x) = \begin{cases} 5x + 2 & \text{if } x < -2 \\ x & \text{if } -2 \leq x \leq 3 \\ 4x - 1 & \text{if } x > 3 \end{cases}$$

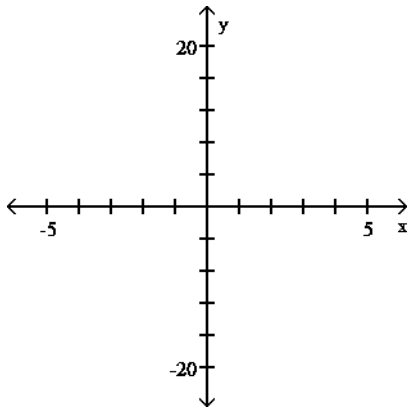

11) _____

A)

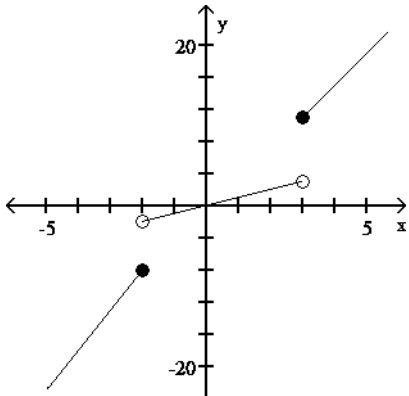

B)

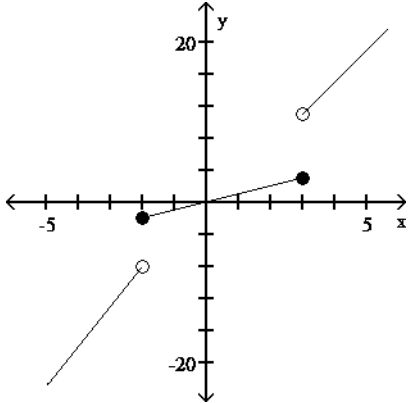

C)

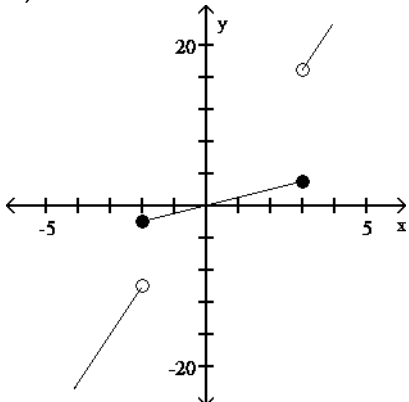

D)

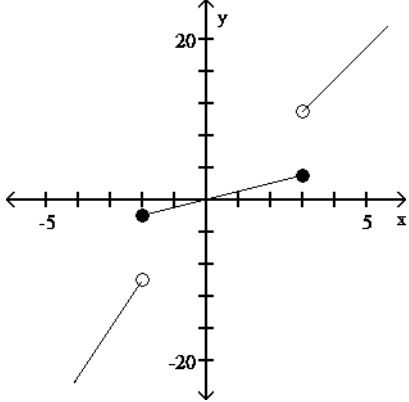

Use a graphing calculator to graph the piecewise-defined function, using the window indicated.

$$12) f(x) = \begin{cases} x+2 & \text{if } x \leq 3 \\ 5 & \text{if } x > 3 \end{cases}; \text{ window } [-4, 6] \text{ by } [-2, 8]$$

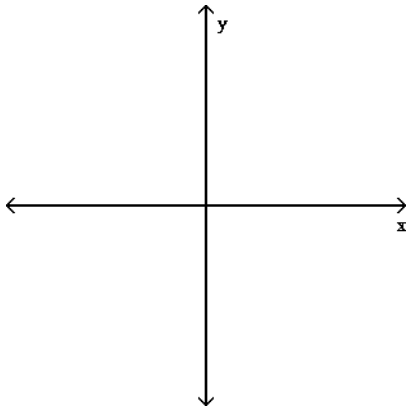

12) _____

A)

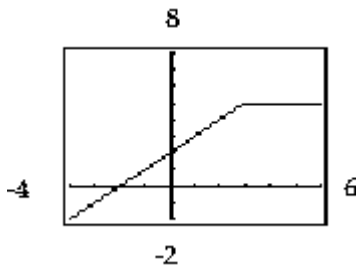

B)

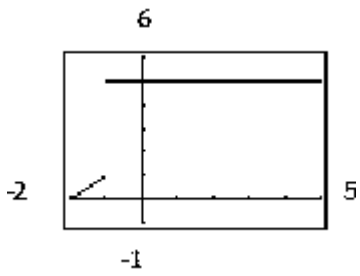

C)

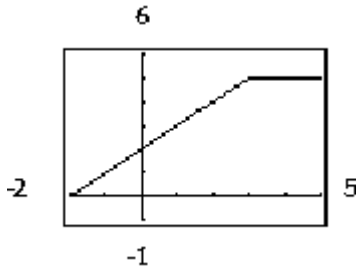

D)

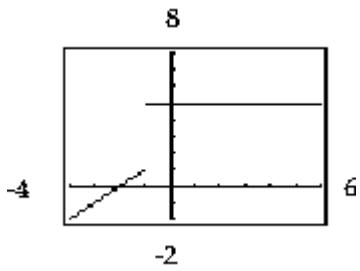

13) $f(x) = \begin{cases} 4-x & \text{if } x \leq 3 \\ 2x-5 & \text{if } x > 3 \end{cases}$; window $[-2, 5]$ by $[-1, 6]$

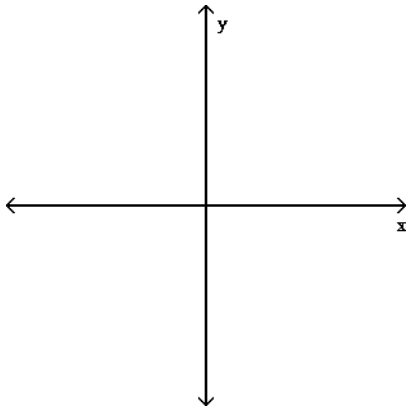

13) _____

A)

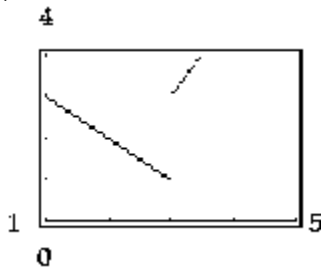

B)

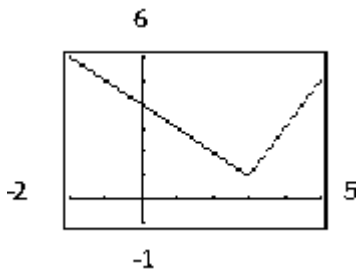

C)

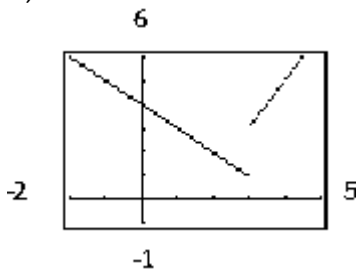

D)

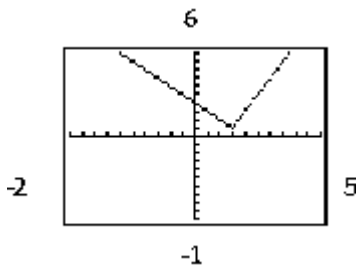

14) $f(x) = \begin{cases} 2-x & \text{if } x < -2 \\ 2x-1 & \text{if } x \geq -2 \end{cases}$ window $[-10, 6]$ by $[-6, 10]$

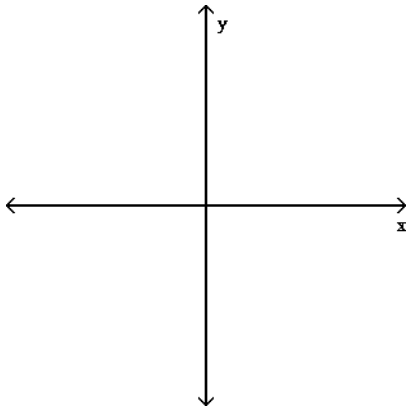

14) _____

A)

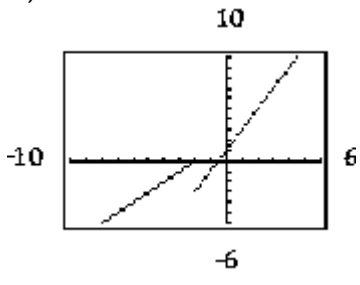

B)

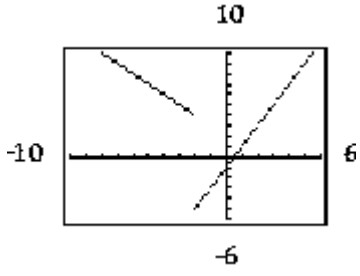

C)

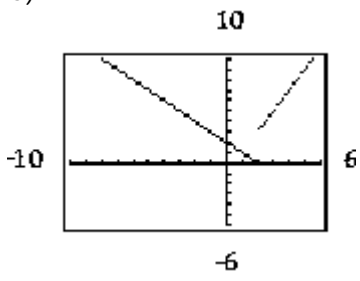

D)

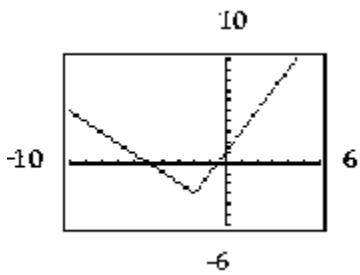

15) $f(x) = \begin{cases} 3x+1 & \text{if } x < 0 \\ 2x-1 & \text{if } x \geq 0 \end{cases}$; window $[-4, 4]$ by $[-4, 4]$

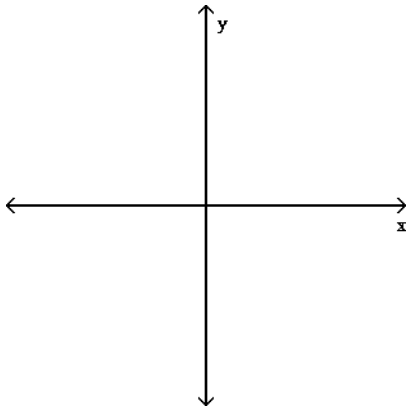

15) _____

A)

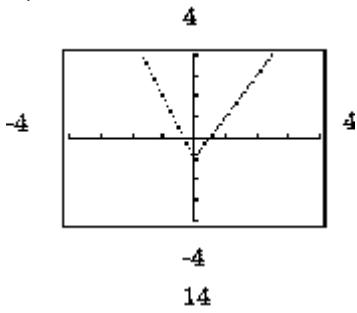

B)

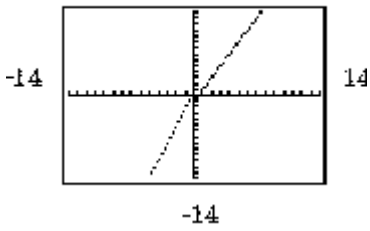

C)

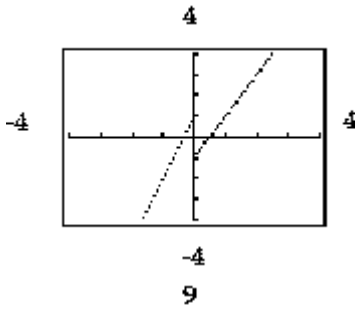

D)

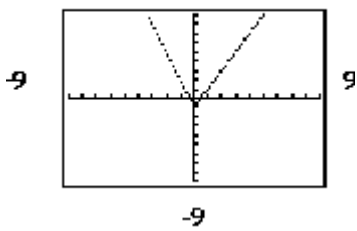

16)
$$f(x) = \begin{cases} x - 1 & \text{if } x < -2 \\ x + 1 & \text{if } -2 \leq x < 3 \\ -2x & \text{if } x \geq 3 \end{cases}$$
 ; window $[-6, 12]$ by $[-12, 6]$

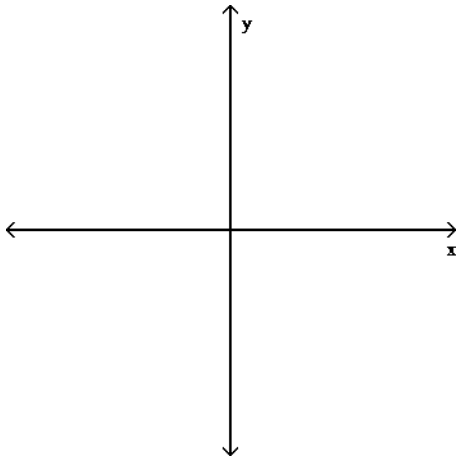

16) _____

A)

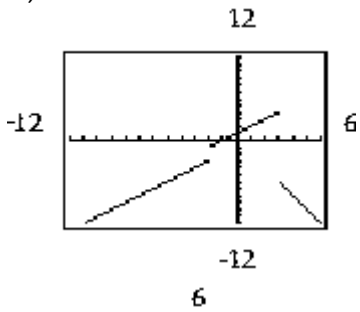

B)

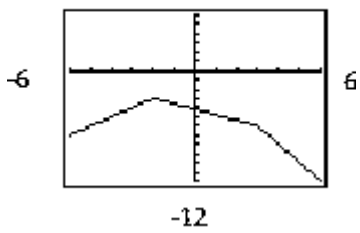

C)

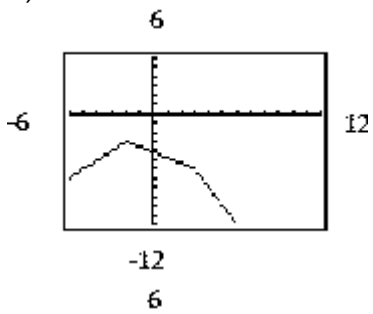

D)

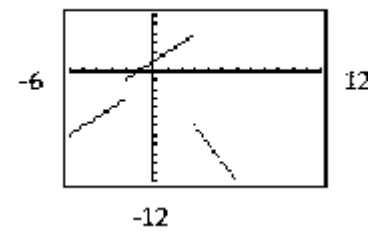

17)
$$f(x) = \begin{cases} x - 1 & \text{if } x < -2 \\ -0.6x - 4.2 & \text{if } -2 \leq x < 3 \\ -2x & \text{if } x \geq 3 \end{cases}$$
 ; window $[-6, 6]$ by $[-12, 6]$

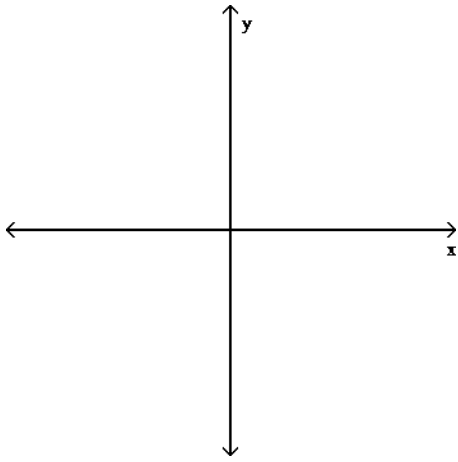

17) _____

A)

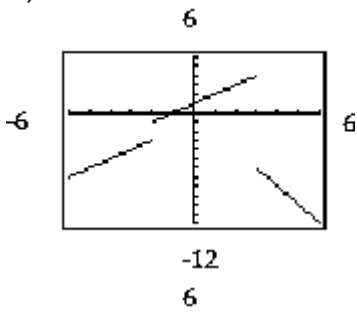

B)

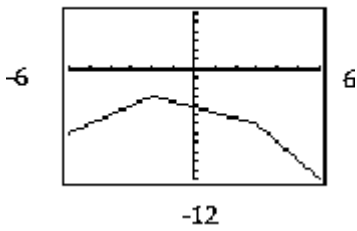

C)

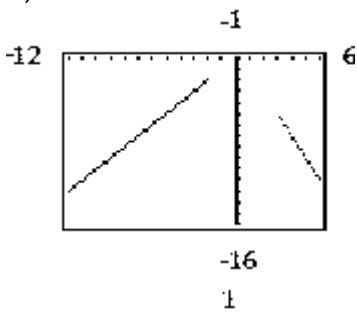

D)

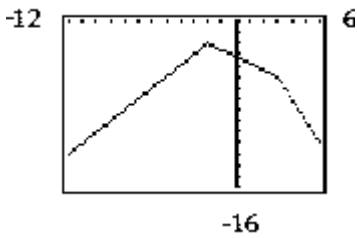

18) $f(x) = \begin{cases} x+3 & \text{if } x < -2 \\ x^2-3 & \text{if } x \geq -2 \end{cases}$; window $[-10, 5]$ by $[-10, 10]$

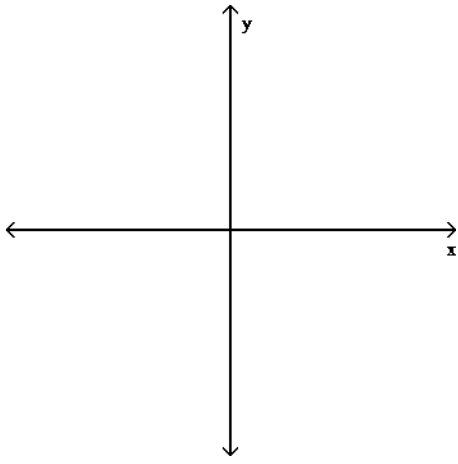

18) _____

A)

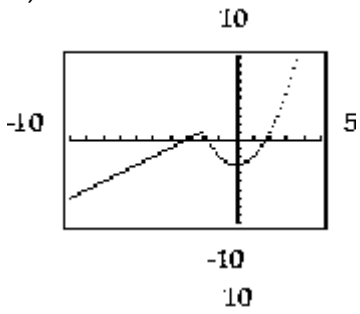

B)

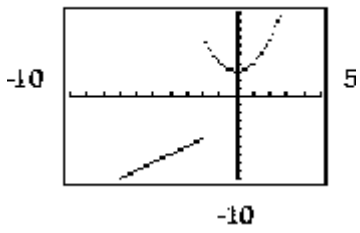

C)

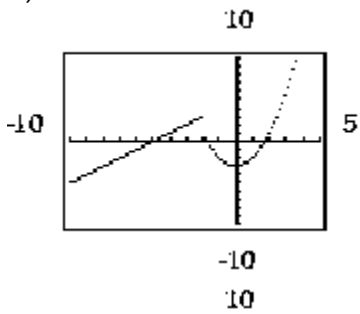

D)

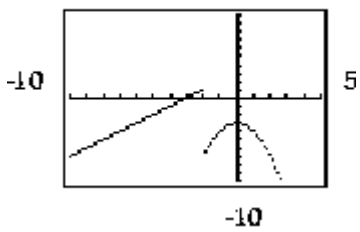

19) $f(x) = \begin{cases} x^3 & \text{if } x < 0 \\ -x^2 - 3 & \text{if } x \geq 0 \end{cases}$, window $[-5, 5]$ by $[-10, 2]$

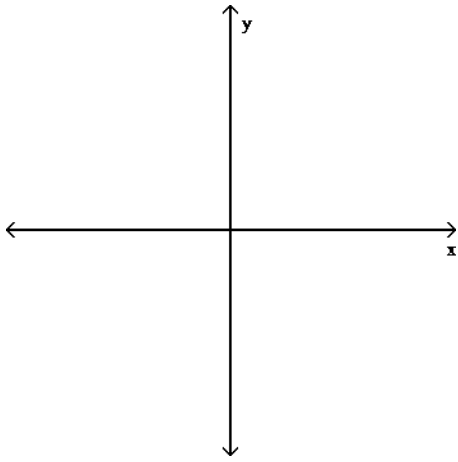

19) _____

A)

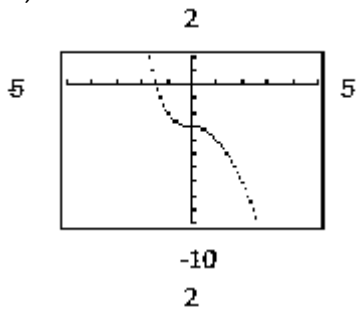

B)

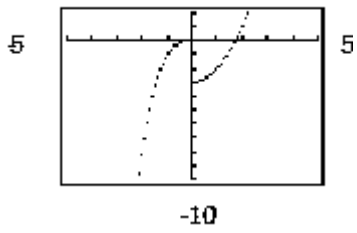

C)

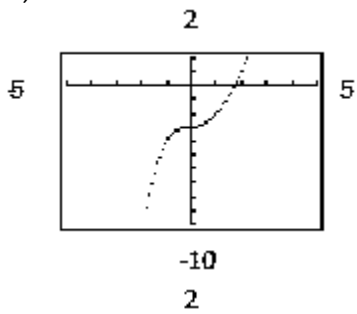

D)

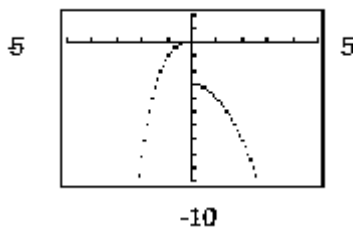

20) $f(x) = \begin{cases} x^3 - 1 & \text{if } x < 2 \\ -x^2 + 1 & \text{if } x \geq 2 \end{cases}$; window $[-5, 5]$ by $[-10, 10]$

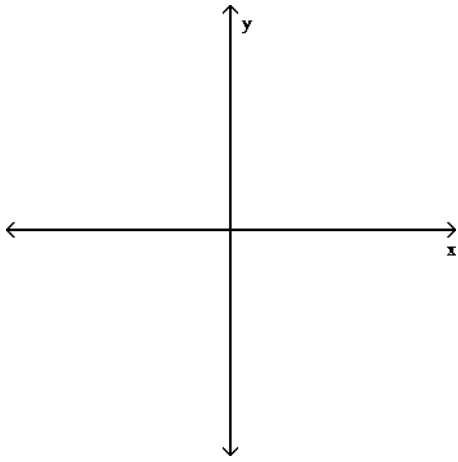

20) _____

A)

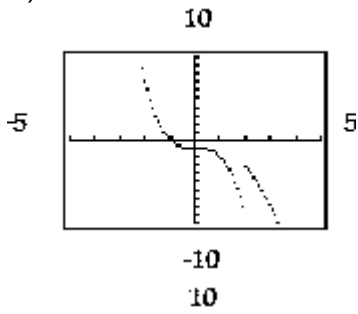

B)

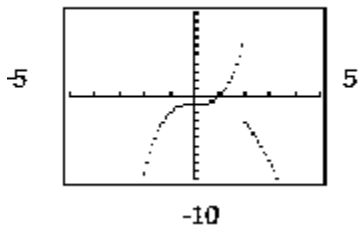

C)

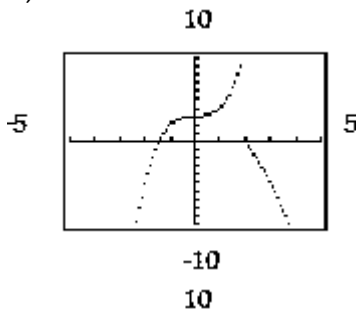

D)

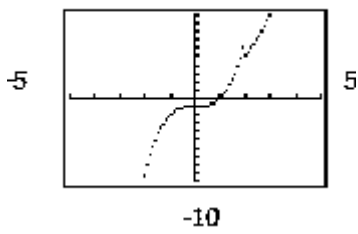

21) $f(x) = \begin{cases} 3\sqrt{x} & \text{if } x < 0 \\ -x^2 + 5 & \text{if } x \geq 0 \end{cases}$; window $[-6, 5]$ by $[-10, 6]$

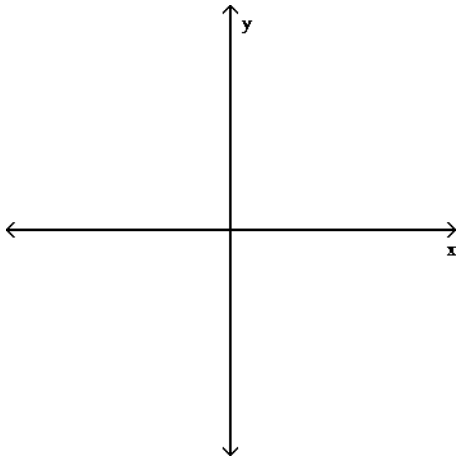

21) _____

A)

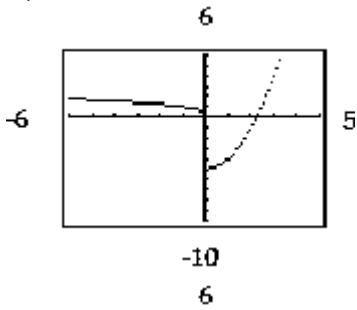

B)

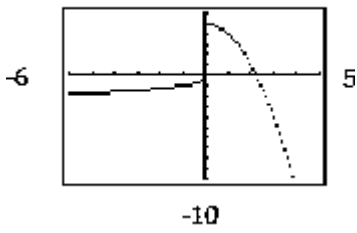

C)

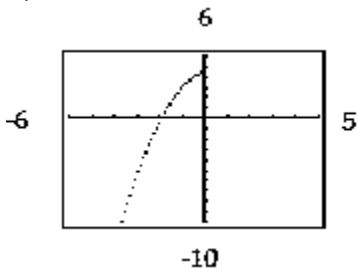

D)

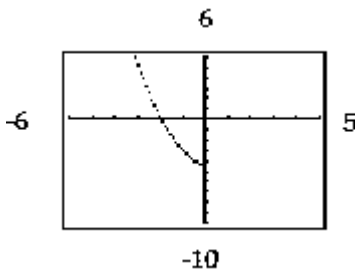

Give a formula for a piecewise-defined function f for the graph shown.

22)

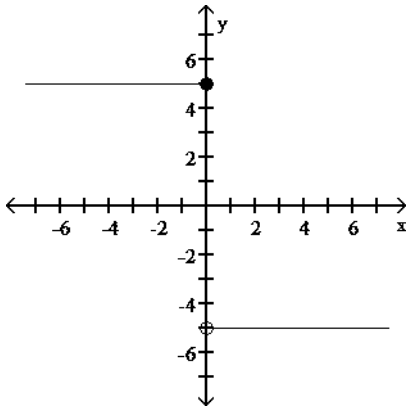

22) _____

A)

$$f(x) = \begin{cases} 5 & \text{if } x < 0 \\ -5 & \text{if } x \geq 0 \end{cases} \quad \text{B)}$$

$$f(x) = \begin{cases} -5 & \text{if } x \leq 0 \\ 5 & \text{if } x > 0 \end{cases}$$

C)

$$f(x) = \begin{cases} 5x & \text{if } x \leq 0 \\ -5x & \text{if } x > 0 \end{cases} \quad \text{D)}$$

$$f(x) = \begin{cases} 5 & \text{if } x \leq 0 \\ -5 & \text{if } x < 0 \end{cases}$$

23)

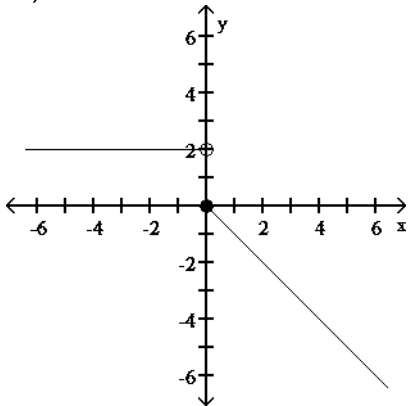

23) _____

A)

$$f(x) = \begin{cases} 2 & \text{if } x < 0 \\ -2x & \text{if } x \geq 0 \end{cases} \quad \text{B)}$$

$$f(x) = \begin{cases} 2 & \text{if } x < 0 \\ -x & \text{if } x \geq 0 \end{cases}$$

C)

$$f(x) = \begin{cases} 2 & \text{if } x \leq 0 \\ -x & \text{if } x > 0 \end{cases} \quad \text{D)}$$

$$f(x) = \begin{cases} 2 & \text{if } x \leq 0 \\ x & \text{if } x > 0 \end{cases}$$

24)

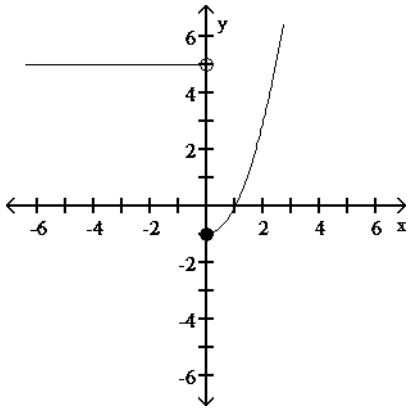

24) _____

A)

$$f(x) = \begin{cases} -5 & \text{if } x \leq 0 \\ x^2 - 1 & \text{if } x > 0 \end{cases} \quad \text{B)}$$

$$f(x) = \begin{cases} 5 & \text{if } x < 0 \\ x^2 - 1 & \text{if } x \geq 0 \end{cases}$$

C)

$$f(x) = \begin{cases} -5 & \text{if } x < 0 \\ |x| - 1 & \text{if } x \geq 0 \end{cases} \quad \text{D)}$$

$$f(x) = \begin{cases} -5 & \text{if } x < 0 \\ x^2 & \text{if } x \geq 0 \end{cases}$$

25)

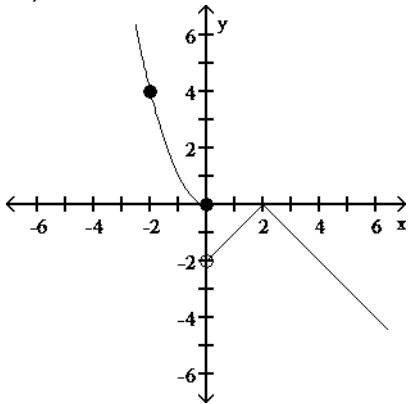

25) _____

A)

$$f(x) = \begin{cases} x^2 & \text{if } x \leq 0 \\ -|x - 2| & \text{if } x > 0 \end{cases} \quad \text{B)}$$

$$f(x) = \begin{cases} x^2 & \text{if } x \leq 0 \\ -|x + 2| & \text{if } x > 0 \end{cases}$$

C)

$$f(x) = \begin{cases} -|x - 2| & \text{if } x < 0 \\ x^2 & \text{if } x \geq 0 \end{cases} \quad \text{D)}$$

$$f(x) = \begin{cases} -x^2 & \text{if } x \leq 0 \\ |x - 2| & \text{if } x > 0 \end{cases}$$

26)

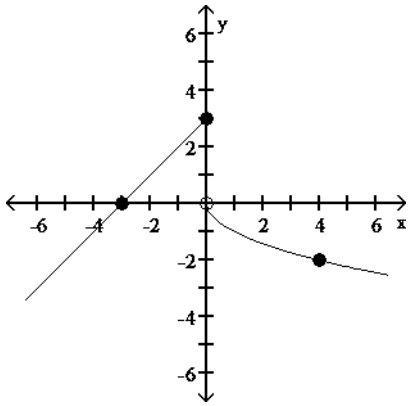

26) _____

A)

$$f(x) = \begin{cases} x+3 & \text{if } x \leq 0 \\ \sqrt{x} & \text{if } x > 0 \end{cases} \quad \text{B)}$$

$$f(x) = \begin{cases} -x+3 & \text{if } x \leq 0 \\ -\sqrt{x} & \text{if } x > 0 \end{cases} \quad \text{C)}$$

C)

$$f(x) = \begin{cases} x+3 & \text{if } x \leq 0 \\ -\sqrt{x} & \text{if } x > 0 \end{cases} \quad \text{D)}$$

$$f(x) = \begin{cases} x-3 & \text{if } x \leq 0 \\ -x^2 & \text{if } x > 0 \end{cases}$$

27)

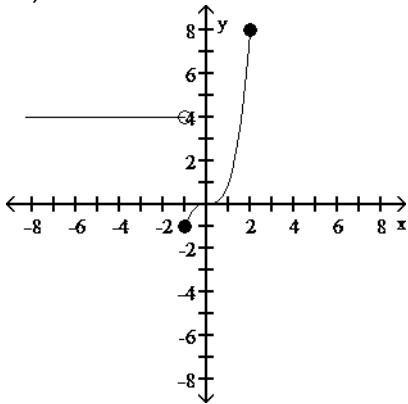

27) _____

A)

$$f(x) = \begin{cases} 4 & \text{if } x < -1 \\ x^2 & \text{if } x \geq -1 \end{cases} \quad \text{B)}$$

$$f(x) = \begin{cases} 4 & \text{if } x < -1 \\ x^3 & \text{if } x \geq -1 \end{cases} \quad \text{C)}$$

C)

$$f(x) = \begin{cases} 4 & \text{if } x < -1 \\ x^3 - 1 & \text{if } x \geq -1 \end{cases} \quad \text{D)}$$

$$f(x) = \begin{cases} -4 & \text{if } x < -1 \\ x^2 - 1 & \text{if } x \geq -1 \end{cases}$$

28)

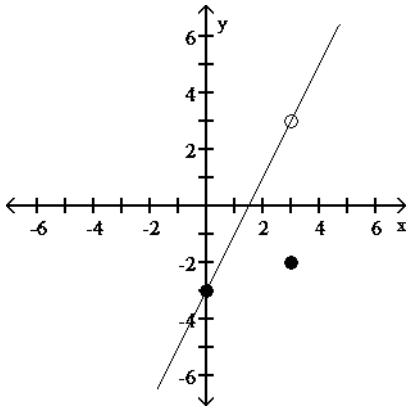

28) _____

A)

$$f(x) = \begin{cases} 2x - 3 & \text{if } x \neq 3 \\ -2 & \text{if } x = 3 \end{cases} \quad \text{B)}$$

$$f(x) = \begin{cases} 2x - 3 & \text{if } x < 3 \\ 2x + 3 & \text{if } x > 3 \end{cases}$$

C)

$$f(x) = \begin{cases} x - 3 & \text{if } x \neq 3 \\ -2 & \text{if } x = 3 \end{cases} \quad \text{D)}$$

$$f(x) = \begin{cases} 2x - 3 & \text{if } x \neq 2 \\ -3 & \text{if } x = 2 \end{cases}$$

29)

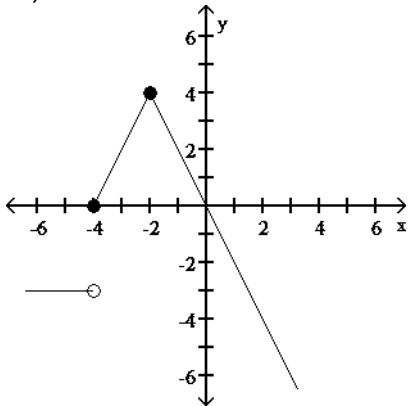

29) _____

A)

$$f(x) = \begin{cases} -3 & \text{if } x \leq -4 \\ -2|x+2|+4 & \text{if } x > -4 \end{cases} \quad \text{B)}$$

$$f(x) = \begin{cases} -3x & \text{if } x < -4 \\ -2|x+2|+4 & \text{if } x \geq -4 \end{cases}$$

C)

$$f(x) = \begin{cases} -3 & \text{if } x < -4 \\ -2|x+2|+4 & \text{if } x \geq -4 \end{cases} \quad \text{D)}$$

$$f(x) = \begin{cases} -3x & \text{if } x < -4 \\ -2|x-2|+4 & \text{if } x \geq -4 \end{cases}$$

30)

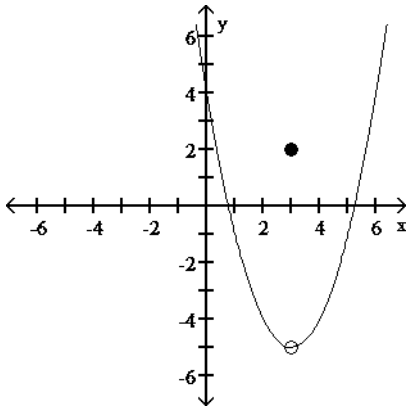

30) _____

A)

$$f(x) = \begin{cases} (x-3)^2 - 5 & \text{if } x \neq 3 \\ 2 & \text{if } x = 3 \end{cases} \quad \text{B)}$$

$$f(x) = \begin{cases} |x-3| - 5 & \text{if } x \neq 3 \\ 2 & \text{if } x = 3 \end{cases}$$

C) $f(x) = (x-3)^2 - 5$ D)

$$f(x) = \begin{cases} (x+3)^2 - 5 & \text{if } x \neq 3 \\ 2 & \text{if } x = 3 \end{cases}$$

31)

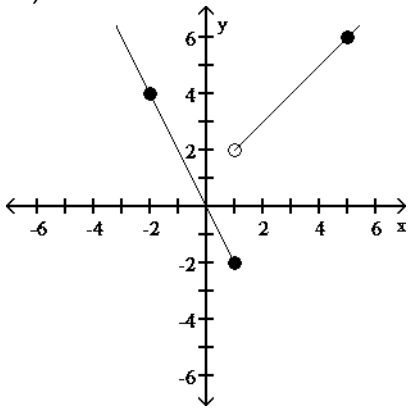

31) _____

A)

$$f(x) = \begin{cases} -2x & \text{if } x \leq 1 \\ x+1 & \text{if } x > 1 \end{cases} \quad \text{B)}$$

$$f(x) = \begin{cases} -x & \text{if } x \leq 1 \\ 2x+1 & \text{if } x > 1 \end{cases}$$

C)

$$f(x) = \begin{cases} -2x & \text{if } x \leq 1 \\ x+2 & \text{if } x > 1 \end{cases} \quad \text{D)}$$

$$f(x) = \begin{cases} 2x & \text{if } x \leq 1 \\ x+1 & \text{if } x > 1 \end{cases}$$

Graph the equation.

32) $y = \lfloor x \rfloor + 1$

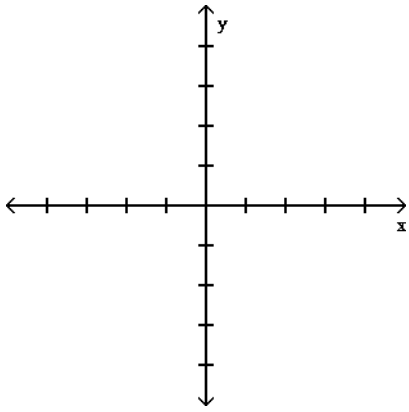

32) _____

A)

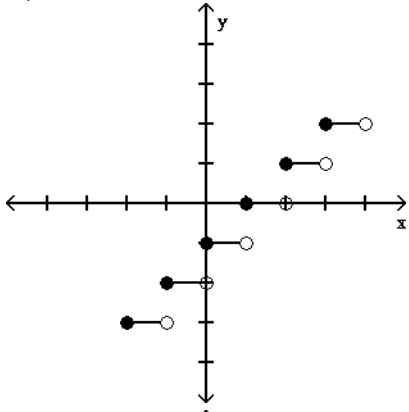

B)

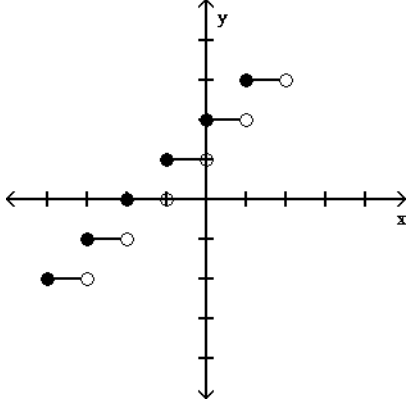

C)

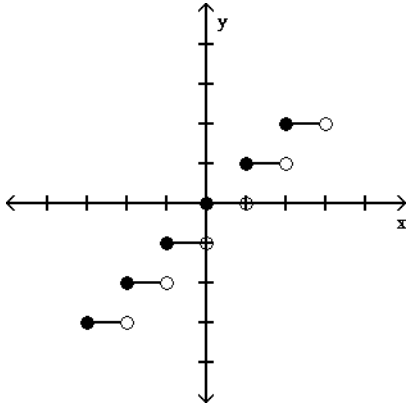

D)

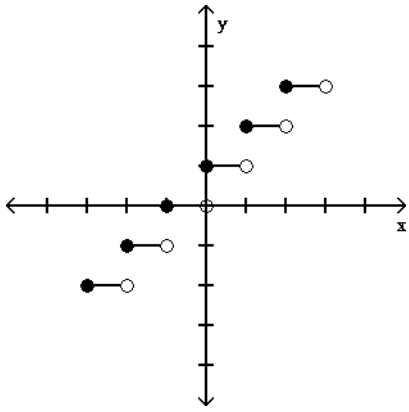

33) $y = \lfloor \lfloor x + 1 \rfloor \rfloor$

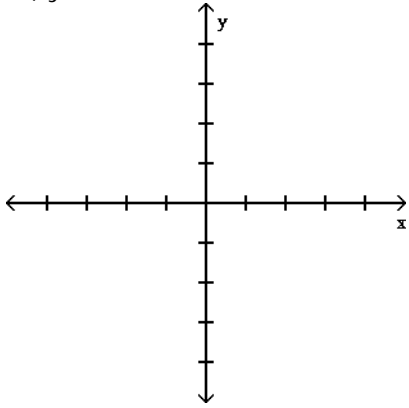

33) _____

A)

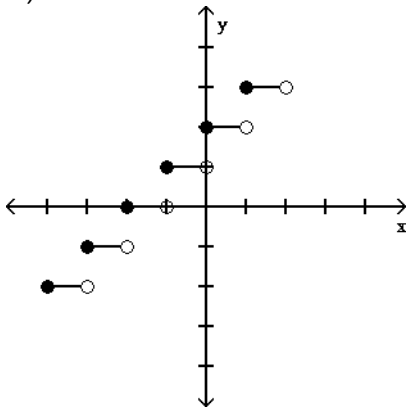

B)

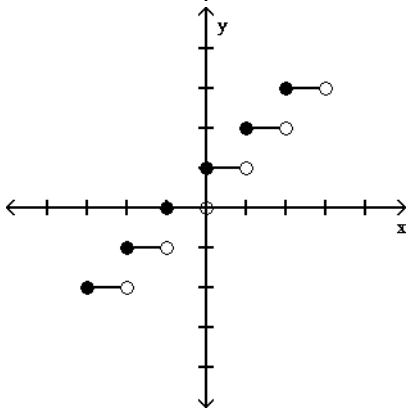

C)

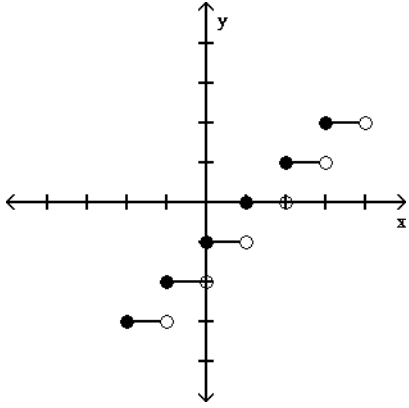
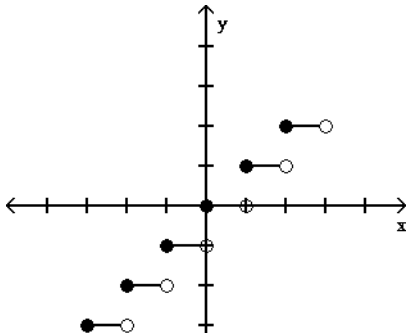

D)

34) $y = \lfloor \lceil x \rceil \rfloor - 1$

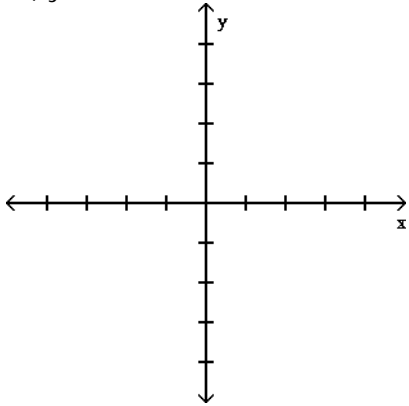

34) _____

A)

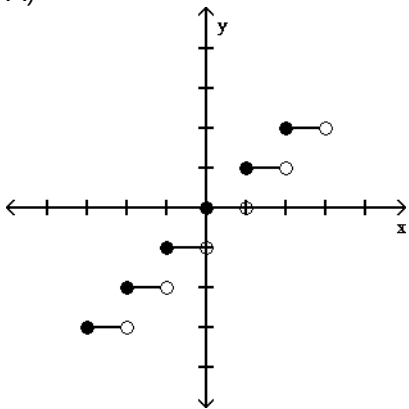

B)

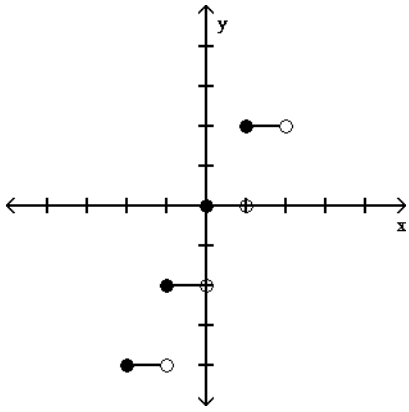

C)

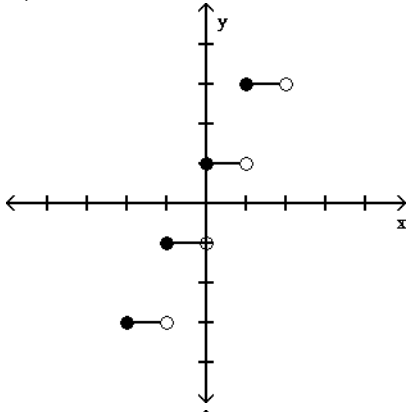

D)

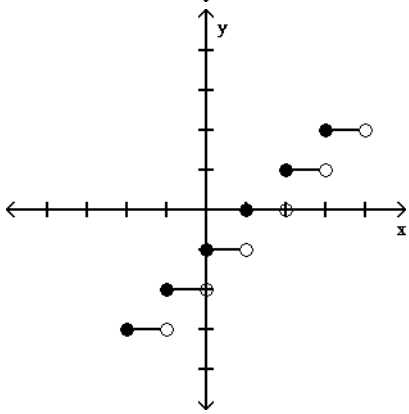

35) $y = \lfloor \lfloor x - 1 \rfloor \rfloor$

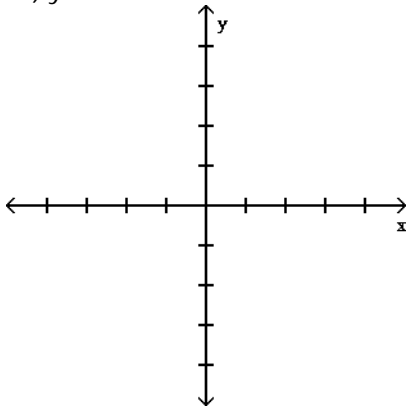

35) _____

A)

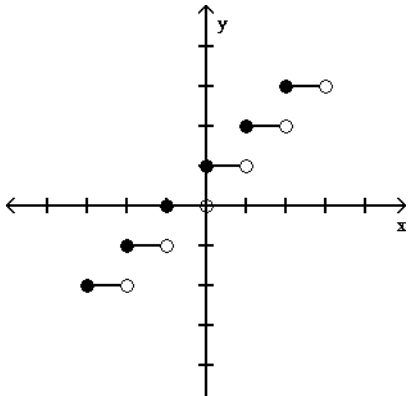

B)

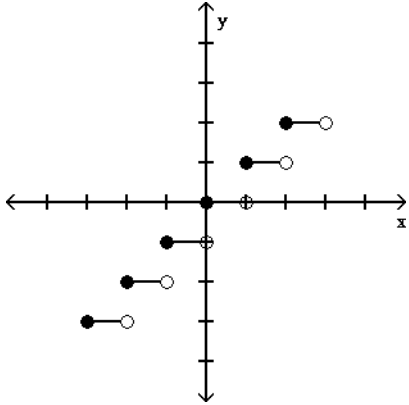

C)

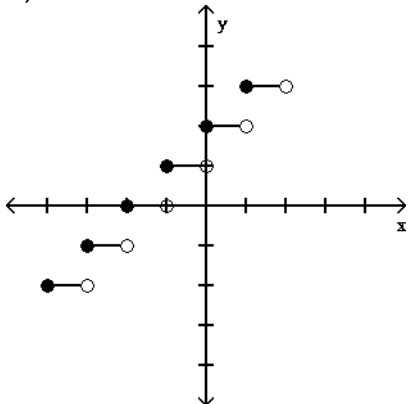

D)

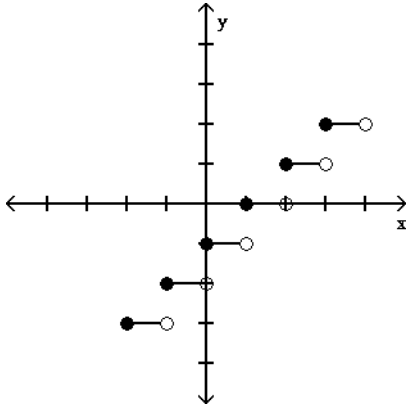

36) $y = 2[x]$

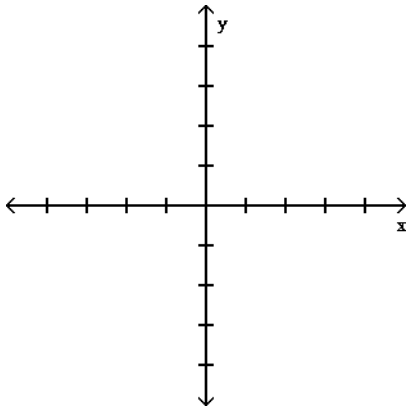

36) _____

A)

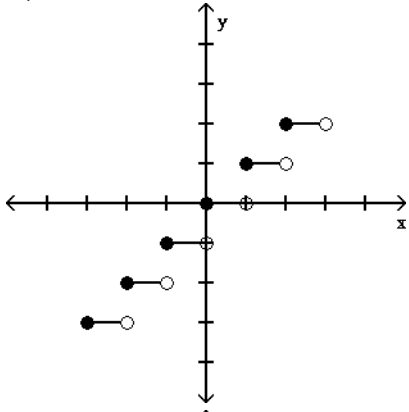

B)

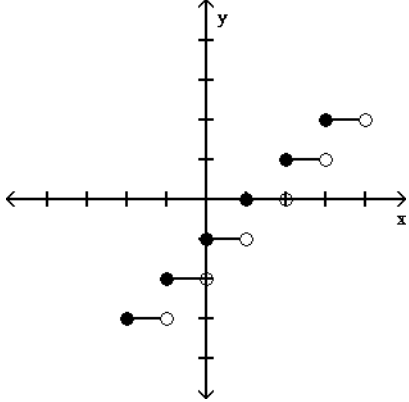

C)

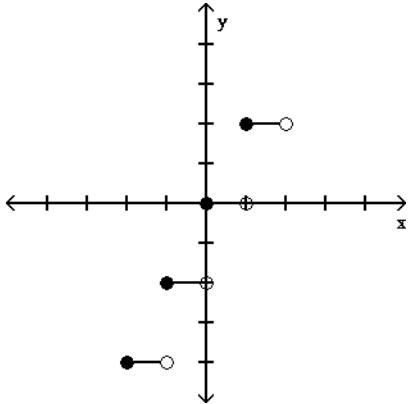

D)

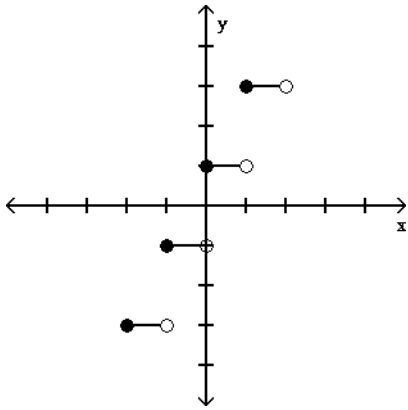

Solve the problem.

37) A video rental company charges \$4 per day for renting a video tape, and then \$3 per day after the first. Use the greatest integer function and write an expression for renting a video tape for x days. 37) _____

- A) $y = 3\lceil x - 1 \rceil + 4$ B) $y + 4 = 3\lceil x \rceil$ C) $y = \lceil 3x + 4 \rceil$ D) $y = 3x + 4$

38) Suppose a car rental company charges \$80 for the first day and \$30 for each additional or partial day. Let $S(x)$ represent the cost of renting a car for x days. Find the value of $S(3.5)$. 38) _____

- A) \$170 B) \$105 C) \$155 D) \$185

39) Suppose a life insurance policy costs \$12 for the first unit of coverage and then \$3 for each additional unit of coverage. Let $C(x)$ be the cost for insurance of x units of coverage. What will 10 units of coverage cost? 39) _____

- A) \$39 B) \$18 C) \$30 D) \$42

40) A salesperson gets a commission of \$400 for the first \$10,000 of sales, and then \$200 for each additional \$10,000 or partial of sales. Let $S(x)$ represent the commission on x dollars of sales. Find the value of $S(45,000)$. 40) _____

- A) \$1100 B) \$900 C) \$1200 D) \$1300

41) Assume it costs 25 cents to mail a letter weighing one ounce or less, and then 20 cents for each additional ounce or fraction of an ounce. Let $L(x)$ be the cost of mailing a letter weighing x ounces. Graph $y = L(x)$. 41) _____

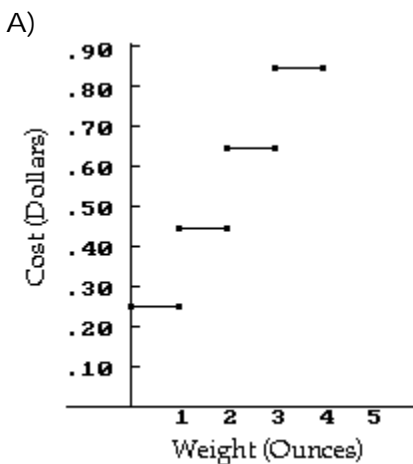

B)

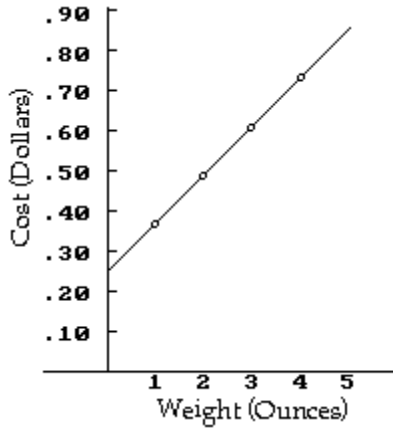

C)

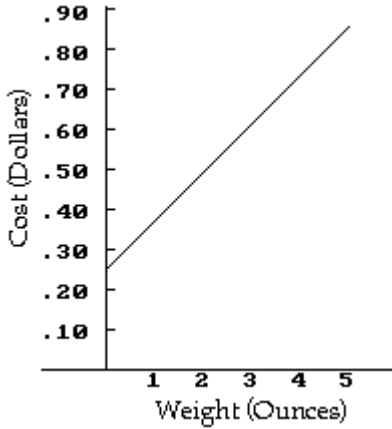

D)

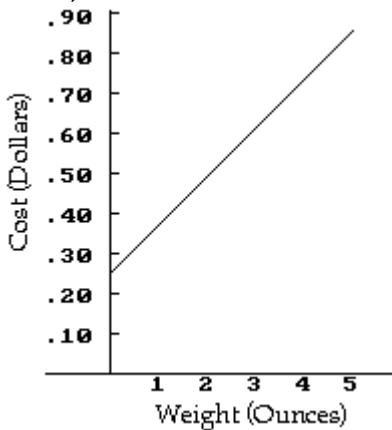

42) Sketch a graph that depicts the amount of water in a 50-gallon tank during the course of the described pumping operations. The tank is initially full, and then a pump is used to take water out of the tank at a rate of 5 gallons per minute. The pump is turned off after 5 minutes. At that point, the pump is changed to one that will pump water into the tank. The change takes 2 minutes and the water level is unchanged during the switch. Then, water is pumped into the tank at a rate of 4 gallons per minute for 3 minutes. 42) _____

A)

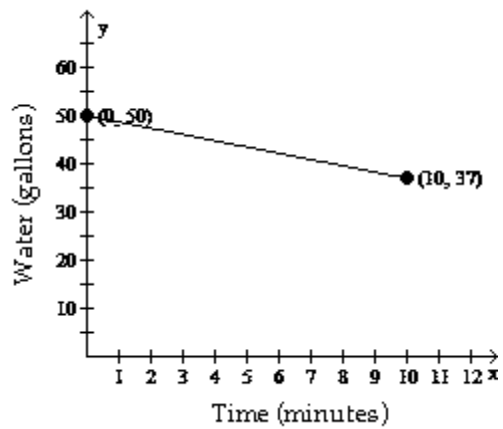

B)

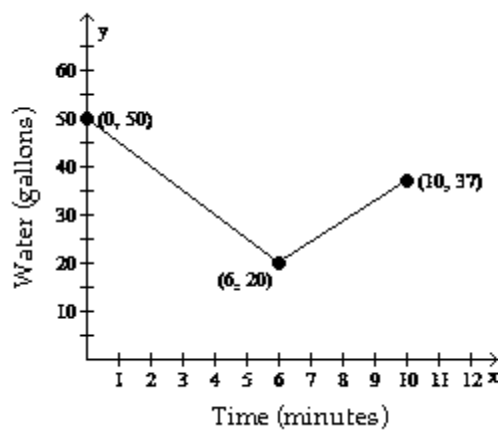

C)

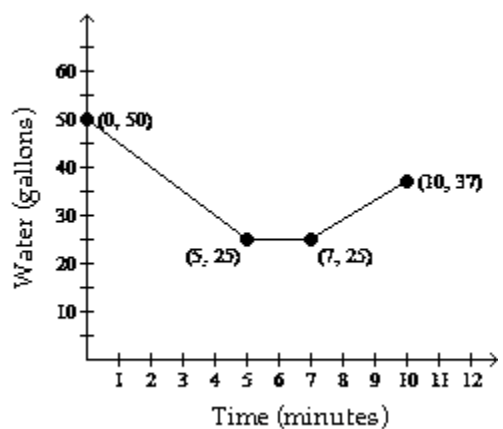

D)

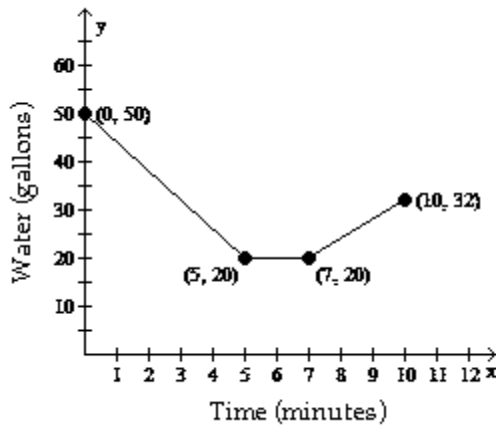

43) The charges for renting a moving van are \$55 for the first 50 miles and \$8 for each additional mile. Assume that a fraction of a mile is rounded up. (i) Determine the cost of driving the van 77 miles. (ii) Find a symbolic representation for a function f that computes the cost of driving the van x miles, where $0 < x \leq 100$. (Hint: express f as a piecewise-constant function.) 43) _____

A) \$1071;

$$f(x) = \begin{cases} 55 & \text{if } 0 < x \leq 50 \\ 55 + 8(x - 50) & \text{if } 50 < x \leq 100 \end{cases} \quad \text{B) } \$271;$$

$$f(x) = \begin{cases} 55 & \text{if } 0 < x \leq 50 \\ 55 + 8(x + 50) & \text{if } 50 < x \leq 100 \end{cases}$$

C) \$271;

$$f(x) = \begin{cases} 55 & \text{if } 0 < x \leq 50 \\ 55 + 8(x - 50) & \text{if } 50 < x \leq 100 \end{cases} \quad \text{D) } \$4451;$$

$$f(x) = \begin{cases} 55 & \text{if } 0 < x \leq 50 \\ 55 + 8(x - 50) & \text{if } 50 < x \leq 100 \end{cases}$$

44) Sketch a graph showing the mileage that a person is from home after x hours if that individual drives at 27.5 mph to a lake 55 miles away, stays at the lake 1.5 hours, and then returns home at a speed of 55 mph. 44) _____

A)

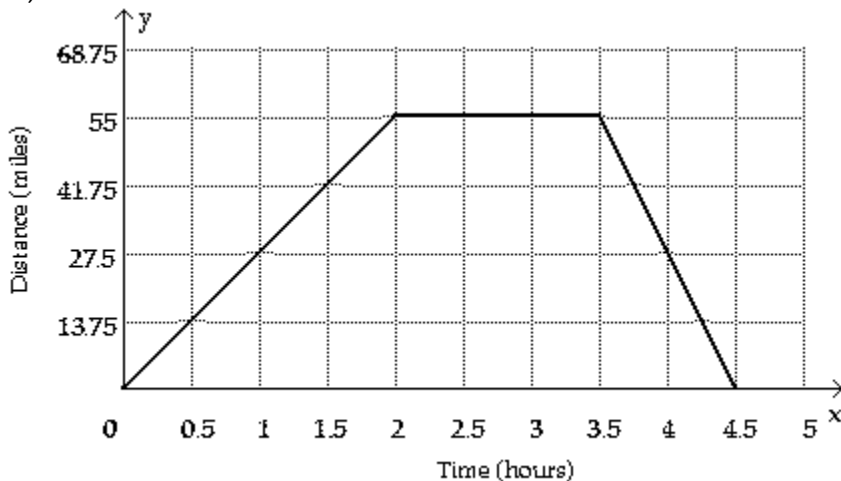

B)

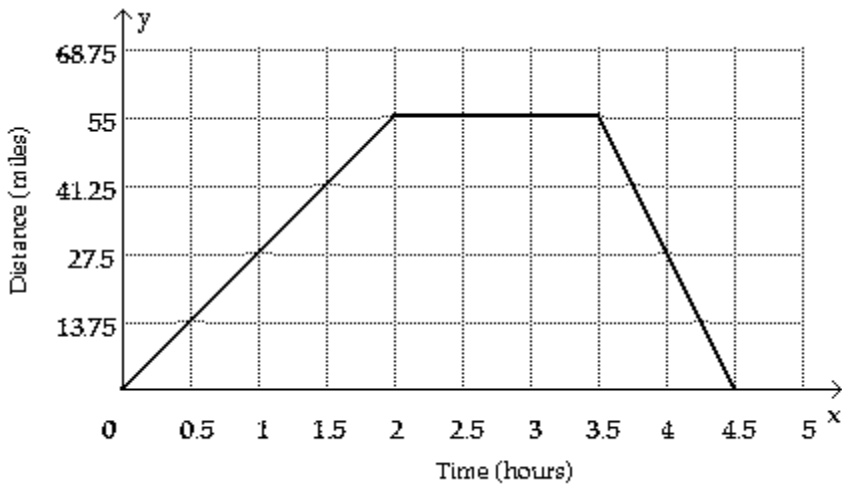

C)

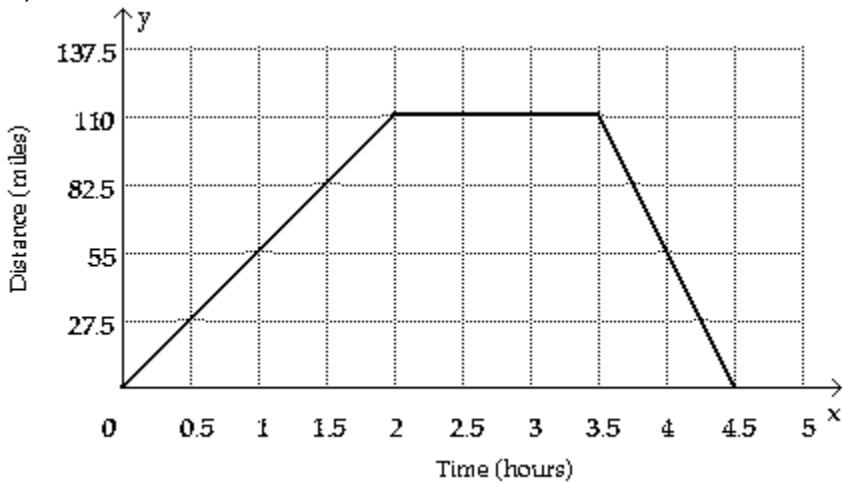

45) In Country X, the average hourly wage in dollars from 1945 to 1995 can be modeled by

$$f(x) = \begin{cases} 0.073(x - 1945) + 0.37 & \text{if } 1945 \leq x < 1970 \\ 0.183(x - 1970) + 3.09 & \text{if } 1970 \leq x \leq 1995 \end{cases}$$

Use f to estimate the average hourly wages in 1950, 1970, and 1990. 45) _____

- A) \$3.46, \$0.37, \$6.75 B) \$0.74, \$3.09, \$6.75
 C) \$0.74, \$2.20, \$6.75 D) \$3.46, \$6.75, \$2.20

Provide an appropriate response.

46) Which of the following is a vertical translation of the function $y = \lfloor x \rfloor$? 46) _____

- A) $y = \lfloor x \rfloor - 2$ B) $y = -\lfloor x \rfloor$ C) $y = \lfloor x - 2 \rfloor$ D) $y = 2\lfloor x \rfloor$

47) Which of the following is a horizontal translation of the function $y = \lfloor x \rfloor$? 47) _____

- A) $y = -\lfloor x \rfloor$ B) $y = \lfloor x \rfloor - 5$ C) $y = \lfloor x - 5 \rfloor$ D) $y = 5\lfloor x \rfloor$

48) Which of the following is a reflection of the function $y = \lfloor x \rfloor$ about the y-axis? Use your graphics calculator to verify your result. 48) _____

- A) $y = -\lfloor x + 1 \rfloor$ B) $y = \lfloor -x + 1 \rfloor$ C) $y = -\lfloor x \rfloor$ D) $y = \lfloor -x \rfloor$

- 1) C
- 2) D
- 3) A
- 4) C
- 5) C
- 6) D
- 7) D
- 8) D
- 9) C
- 10) A
- 11) B
- 12) A
- 13) B
- 14) B
- 15) C
- 16) D
- 17) B
- 18) A
- 19) D
- 20) B
- 21) B
- 22) D
- 23) B
- 24) B
- 25) A
- 26) C
- 27) B
- 28) A
- 29) C
- 30) A
- 31) A
- 32) D
- 33) B
- 34) D
- 35) D
- 36) C
- 37) A
- 38) A
- 39) A
- 40) C
- 41) D
- 42) C
- 43) C
- 44) B
- 45) B
- 46) A
- 47) C
- 48) D

Exam

Name _____

MULTIPLE CHOICE. Choose the one alternative that best completes the statement or answers the question.

Find the requested composition or operation.

1) $f(x) = 2 - 2x$, $g(x) = -5x + 2$

Find $(f + g)(x)$. 1) _____

- A) $-7x + 4$ B) $-5x + 2$ C) $3x + 4$ D) $-3x$

2) $f(x) = 9x - 3$, $g(x) = 5x - 2$

Find $(f - g)(x)$. 2) _____

- A) $-4x + 1$ B) $14x - 5$ C) $4x - 1$ D) $4x - 5$

3) $f(x) = \sqrt{4x + 3}$, $g(x) = \sqrt{16x - 4}$

Find $(fg)(x)$. 3) _____

- A) $(4x + 3)(4x - 2)$ B) $(4x + 3)(16x - 4)$
C) $(\sqrt{4x + 3})(\sqrt{16x - 4})$ D) $(4x - 2)(\sqrt{4x + 3})$

4) $f(x) = 4x - 6$, $g(x) = 7x - 9$

Find $(fg)(x)$. 4) _____

- A) $11x^2 - 78x - 15$ B) $28x^2 - 78x + 54$ C) $28x^2 - 51x + 54$ D) $28x^2 + 54$

5) $f(x) = 7x^2 - 8x$, $g(x) = x^2 - 3x - 40$

Find $\left(\frac{f}{g}\right)(x)$. 5) _____

- A) $\frac{7x}{x + 1}$ B) $\frac{7x^2 - 8x}{x^2 - 3x - 40}$ C) $\frac{7x - 8}{-3}$ D) $\frac{7 - x}{40}$

6) $f(x) = 8x + 6$, $g(x) = 2x - 1$

Find $(f \circ g)(x)$. 6) _____

- A) $16x + 5$ B) $16x + 11$ C) $16x - 2$ D) $16x + 14$

7) $f(x) = \sqrt{x + 2}$, $g(x) = 8x - 6$

Find $(f \circ g)(x)$. 7) _____

- A) $8\sqrt{x - 4}$ B) $2\sqrt{2x - 1}$ C) $8\sqrt{x + 2} - 6$ D) $2\sqrt{2x + 1}$

8) $f(x) = 4x^2 + 4x + 5$, $g(x) = 4x - 4$

Find $(g \circ f)(x)$. 8) _____

- A) $4x^2 + 4x + 1$ B) $16x^2 + 16x + 24$ C) $4x^2 + 16x + 16$ D) $16x^2 + 16x + 16$

9) $f(x) = \frac{8}{x-6}$, $g(x) = \frac{3}{7x}$
 Find $(f \circ g)(x)$. 9) _____

- A) $\frac{8x}{3-42x}$ B) $\frac{56x}{3+42x}$ C) $\frac{3x-18}{56x}$ D) $\frac{56x}{3-42x}$

10) $f(x) = \frac{x-3}{5}$, $g(x) = 5x+3$
 Find $(g \circ f)(x)$. 10) _____

- A) x B) $x+6$ C) $5x+12$ D) $x - \frac{3}{5}$

Perform the requested composition or operation.

11) Find $(f+g)(3)$ when $f(x) = x-5$ and $g(x) = x+2$. 11) _____
 A) -1 B) 9 C) 3 D) 13

12) Find $(f-g)(5)$ when $f(x) = 3x^2+5$ and $g(x) = x+6$. 12) _____
 A) 81 B) -85 C) 69 D) 79

13) Find $(fg)(-2)$ when $f(x) = x+5$ and $g(x) = 4x^2+12x+2$. 13) _____
 A) 42 B) -54 C) -18 D) -126

14) Find $\left(\frac{f}{g}\right)(-5)$ when $f(x) = 3x-6$ and $g(x) = 2x^2+14x+4$. 14) _____

- A) $\frac{2}{9}$ B) $\frac{21}{16}$ C) $-\frac{1}{8}$ D) 0

15) Find $(f \circ g)(-9)$ when $f(x) = 6x-4$ and $g(x) = 8x^2-4x+4$. 15) _____
 A) -228 B) -196 C) 27,148 D) 4124

16) Find $(g \circ f)(7)$ when $f(x) = -8x+6$ and $g(x) = -4x^2+2x+5$. 16) _____
 A) -10,095 B) 78 C) 1422 D) 105

Find the specified domain.

17) For $f(x) = 2x-5$ and $g(x) = \sqrt{x+4}$, what is the domain of $(f+g)$? 17) _____
 A) $(-4, 4)$ B) $[0, \infty)$ C) $[4, \infty)$ D) $[-4, \infty)$

18) For $f(x) = 2x-5$ and $g(x) = \sqrt{x+4}$, what is the domain of $\left(\frac{f}{g}\right)$? 18) _____

- A) $(-4, 4)$ B) $(-4, \infty)$ C) $[4, \infty)$ D) $[0, \infty)$

19) For $f(x) = 2x-5$ and $g(x) = \sqrt{x+6}$, what is the domain of $(f \circ g)$? 19) _____
 A) $[6, \infty)$ B) $[-6, \infty)$ C) $(-6, 6)$ D) $[0, \infty)$

20) For $f(x) = 2x-5$ and $g(x) = \sqrt{x+7}$, what is the domain of $(g \circ f)$? 20) _____

- A) $[7, \infty)$ B) $[\infty, -1)$ C) $(-7, 7)$ D) $[-1, \infty)$

21) For $f(x) = x^2 - 1$ and $g(x) = 2x + 3$, what is the domain of $(f - g)$? 21) _____

- A) $[0, \infty)$ B) $(-\infty, \infty)$ C) $(-1, 1)$ D) $[1, \infty)$

22) For $f(x) = x^2 - 9$ and $g(x) = 2x + 3$, what is the domain of $\left(\frac{f}{g}\right)$? 22) _____

- A) $(-3, 3)$ B) $\left(-\infty, -\frac{3}{2}\right) \cup \left(-\frac{3}{2}, \infty\right)$
 C) $(-\infty, \infty)$ D) $\left[-\frac{3}{2}, \infty\right)$

23) For $f(x) = x^2 - 25$ and $g(x) = 2x + 3$, what is the domain of $\left(\frac{g}{f}\right)$? 23) _____

- A) $(-\infty, \infty)$ B) $(-\infty, -5) \cup (-5, 5) \cup (5, \infty)$
 C) $\left[-\frac{3}{2}, \infty\right)$ D) $\left(-\infty, \frac{3}{2}\right) \cup \left(-\frac{3}{2}, \infty\right)$

24) For $f(x) = x^2 - 25$ and $g(x) = 2x + 3$, what is the domain of $(f \circ g)$? 24) _____

- A) $(-5, 5)$ B) $[5, \infty)$ C) $[0, \infty)$ D) $(-\infty, \infty)$

25) For $f(x) = \sqrt{x-2}$ and $g(x) = \frac{1}{x-9}$, what is the domain of $(f \cdot g)$? 25) _____

- A) $[2, 9) \cup (9, \infty)$ B) $(2, 9) \cup (9, \infty)$ C) $[0, 9) \cup (9, \infty)$ D) $[2, \infty)$

26) For $g(x) = \sqrt{x+6}$ and $h(x) = \frac{1}{x-8}$, what is the domain of $(h \circ g)$? 26) _____

- A) $[0, 58) \cup (58, \infty)$ B) $[-6, 58) \cup (58, \infty)$ C) $[-6, 8) \cup (8, \infty)$ D) $[0, 8) \cup (8, \infty)$

Use the graphs to evaluate the expression.

27) $f(1) + g(-4)$

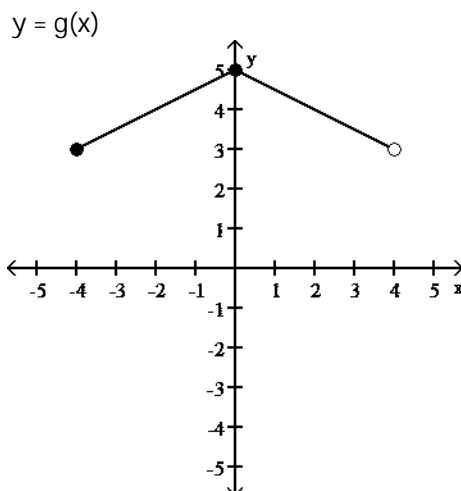
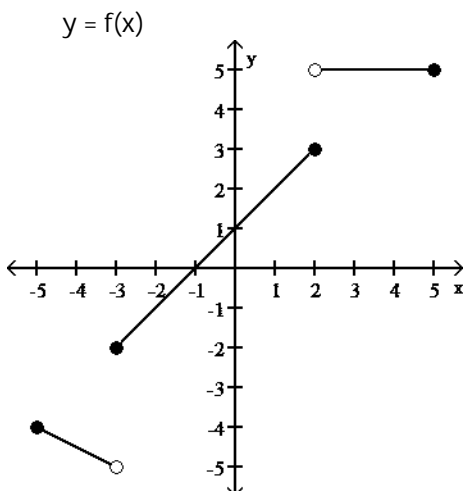

27) _____

- A) 6 B) 3 C) 5 D) 8

28) $f(0) - g(-4)$

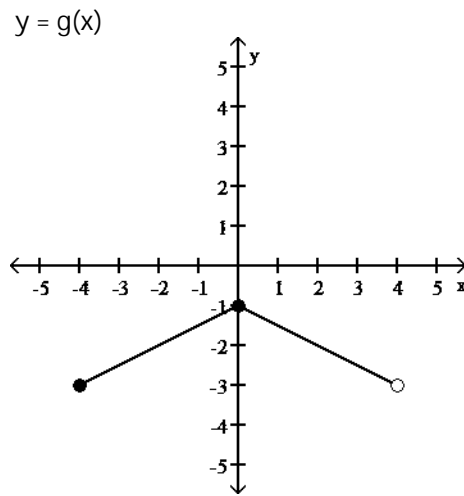
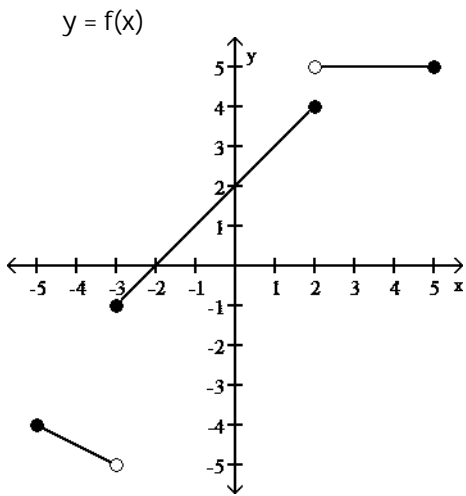

28) _____

- A) 5 B) 4 C) 8 D) 2

29) $f(3) - g(4)$

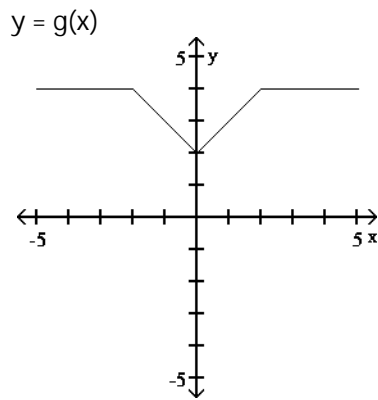
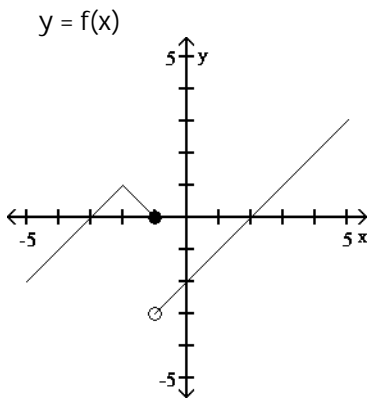

29) _____

- A) -3 B) $\frac{1}{4}$ C) 4 D) 5

30) $f(4) * g(4)$

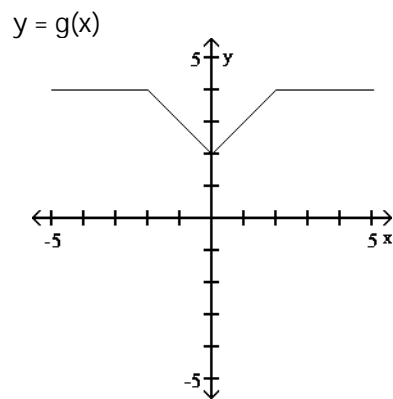
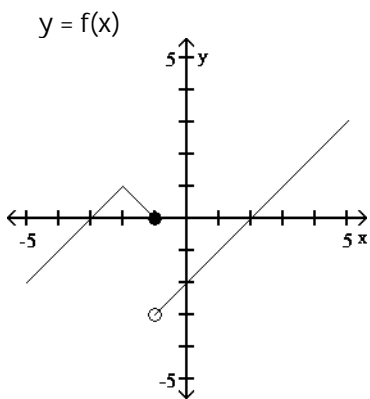

30) _____

- A) 6 B) $\frac{1}{2}$ C) 8 D) -2

31) $(g \circ f)(-2)$

$y = f(x)$

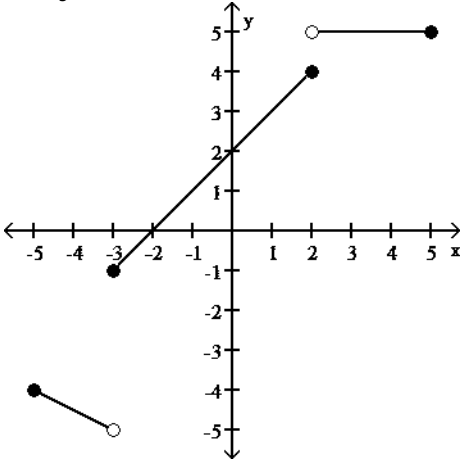

$y = g(x)$

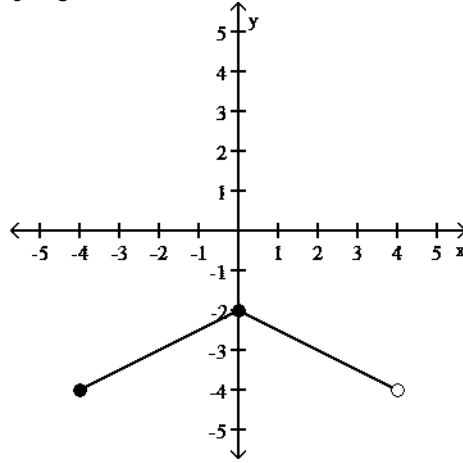

31) _____

- A) -3.5 B) -1 C) -2 D) -5

32) $(f \circ g)(-4)$

$y = f(x)$

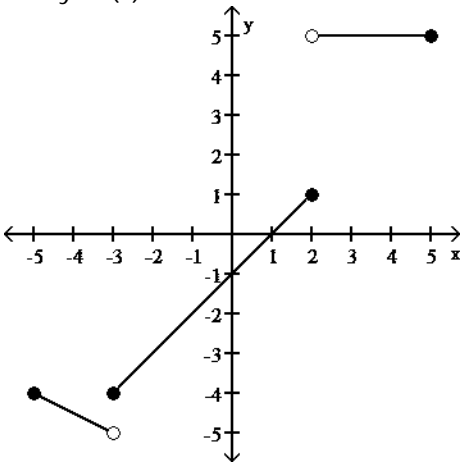

$y = g(x)$

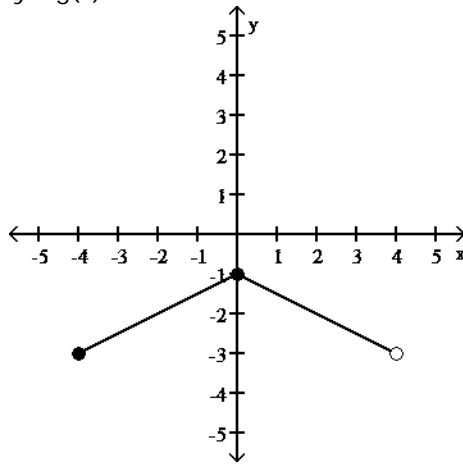

32) _____

- A) -3 B) -6 C) -4 D) -5.5

33) $(f \circ g)(-1)$

$y = f(x)$

$y = g(x)$

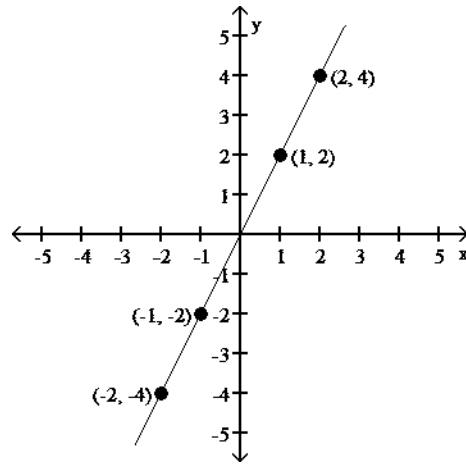
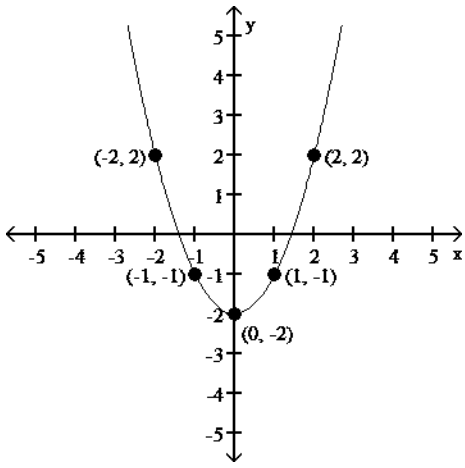

33) _____

- A) 2 B) 3 C) 5 D) 1

34) $(g \circ f)(0)$

$y = f(x)$

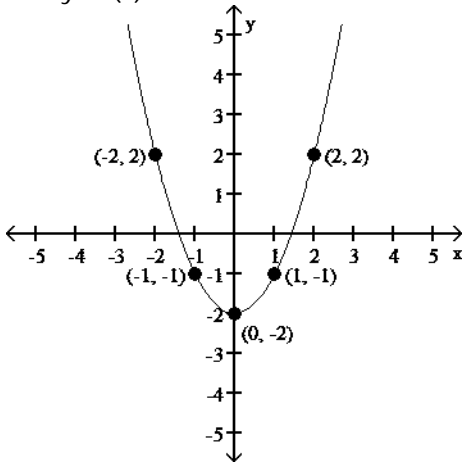

$y = g(x)$

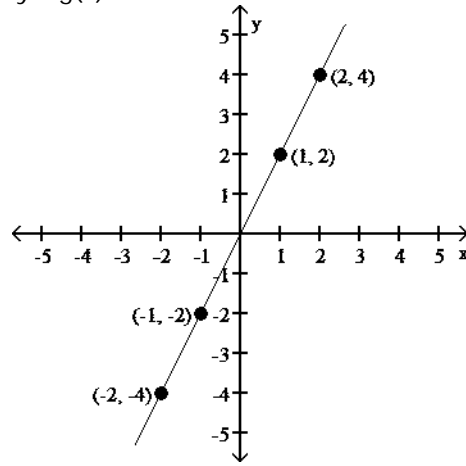

34) _____

- A) -4 B) -5 C) -6 D) -3

35) $(f + g)(3)$

$y = f(x)$

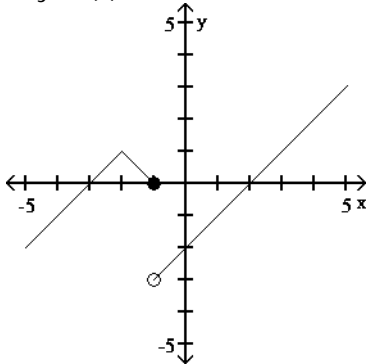

$y = g(x)$

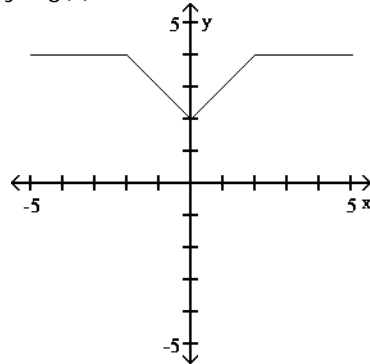

35) _____

- A) $\frac{1}{4}$ B) 4 C) -3 D) 5

36) $g(f(3))$

$y = f(x)$

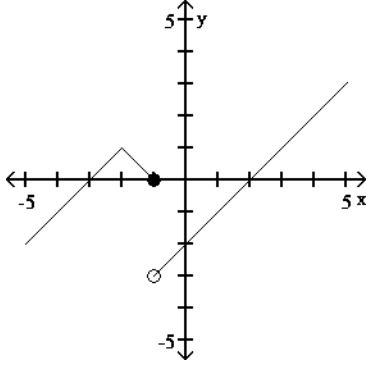

$y = g(x)$

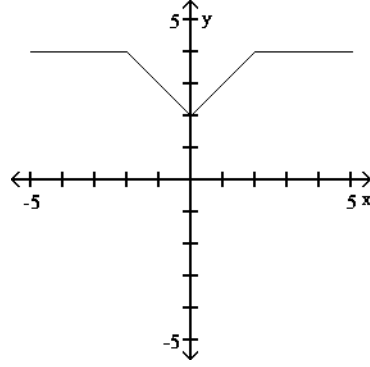

36) _____

- A) 3 B) 4 C) -3 D) 5

Use the tables to evaluate the expression if possible.

37) Find $(f + g)(-8)$.

x	-8	-5	5
$f(x)$	8	6	-5

x	-8	1	5
$g(x)$	-7	-2	-4

37) _____

- A) 10 B) -9 C) 4 D) 1

38) Find $(fg)(-6)$.

x	-6	1	8
$f(x)$	-7	6	8

x	-6	3	8
$g(x)$	-7	8	-6

38) _____

- A) 36 B) 48 C) -48 D) 49

39) Find $(g \circ f)(13)$.

x	9	11	13
$f(x)$	81	121	169

x	121	169	100	81	144
$g(x)$	110	158	89	70	133

39) _____

- A) 136 B) 158 C) 110 D) 73

40) Find $(f \circ g)(7)$.

x	19	15	11	13
$f(x)$	38	30	22	26

x	9	7	10	8
$g(x)$	17	13	19	15

40) _____

- A) 26 B) 7 C) 13 D) 30

41) Find $(g \circ f)(5)$.

x	5	8	6	12
$f(x)$	6	10	25	27

x	7	12	5	6
$g(x)$	13	9	12	11

41) _____

- A) 5 B) 25 C) 11 D) 9

42) Find $(f \circ f)(3)$.

x	3	6	4	2
f(x)	4	3	13	15

x	5	3	6	4
g(x)	9	5	11	7

42) _____

- A) 11 B) 13 C) 7 D) 3

43) Find $(g \circ g)(9)$.

x	9	12	10	20
f(x)	10	18	49	51

x	11	20	9	10
g(x)	21	17	20	19

43) _____

- A) 19 B) 17 C) 51 D) 49

Determine whether $(f \circ g)(x) = x$ and whether $(g \circ f)(x) = x$.

44) $f(x) = \sqrt[5]{x-14}$, $g(x) = x^5 + 14$ 44) _____

- A) Yes, yes B) No, no C) Yes, no D) No, yes

45) $f(x) = x^2 + 5$, $g(x) = \sqrt{x} - 5$ 45) _____

- A) No, yes B) Yes, no C) No, no D) Yes, yes

46) $f(x) = \frac{1}{x}$, $g(x) = x$ 46) _____

- A) No, yes B) Yes, yes C) Yes, no D) No, no

47) $f(x) = \sqrt{x+1}$, $g(x) = x^2$ 47) _____

- A) No, no B) No, yes C) Yes, yes D) Yes, no

48) $f(x) = x^3 + 1$, $g(x) = \sqrt[3]{x-1}$ 48) _____

- A) No, yes B) Yes, yes C) Yes, no D) No, no

$$\frac{f(x+h) - f(x)}{h}$$

Determine the difference quotient

$(h \neq 0)$ for the function f . Simplify completely.

49) $f(x) = 6x - 7$ 49) _____

- A) $\frac{7}{6}$ B) 6 C) $-6h$ D) 7

50) $f(x) = x^2 + 11x - 4$ 50) _____

- A) $2x + 11 + 1h$ B) $2xh + 11h + 11h^2$
C) $2x + 11$ D) $1x + 6 + 2h$

51) $f(x) = 2 - 5x^3$ 51) _____

A) $-5(x^2 - xh - h^2)$ B) $-5(3x^2 + 3xh + h^2)$

C) $-5(3x^2 - 3x - h)$ D) $-6x^2$

Consider the function h as defined. Find functions f and g such that $(f \circ g)(x) = h(x)$.

52) $h(x) = \frac{1}{x^2 - 8}$ 52) _____

A) $f(x) = \frac{1}{x^2}$, $g(x) = -\frac{1}{8}$ B) $f(x) = \frac{1}{x}$, $g(x) = x^2 - 8$

C) $f(x) = \frac{1}{x^2}$, $g(x) = x - 8$ D) $f(x) = \frac{1}{8}$, $g(x) = x^2 - 8$

53) $h(x) = |9x + 6|$ 53) _____

A) $f(x) = x$, $g(x) = 9x + 6$ B) $f(x) = |-x|$, $g(x) = 9x - 6$

C) $f(x) = |x|$, $g(x) = 9x + 6$ D) $f(x) = -|x|$, $g(x) = 9x + 6$

54) $h(x) = \frac{1}{x^2} + 10$ 54) _____

A) $f(x) = \frac{1}{x}$, $g(x) = \frac{1}{x} + 10$ B) $f(x) = \frac{1}{x^2}$, $g(x) = 10$

C) $f(x) = x + 10$, $g(x) = \frac{1}{x^2}$ D) $f(x) = x$, $g(x) = \frac{1}{x} + 10$

55) $h(x) = \frac{4}{\sqrt{4x+9}}$ 55) _____

A) $f(x) = \sqrt{4x+9}$, $g(x) = 4$ B) $f(x) = \frac{4}{x}$, $g(x) = 4x + 9$

C) $f(x) = 4$, $g(x) = \sqrt{4+9}$ D) $f(x) = \frac{4}{\sqrt{x}}$, $g(x) = 4x + 9$

56) $h(x) = (5x + 3)^7$ 56) _____

A) $f(x) = 5x^7$, $g(x) = x + 3$ B) $f(x) = 5x + 3$, $g(x) = x^7$

C) $f(x) = x^7$, $g(x) = 5x + 3$ D) $f(x) = (5x)^7$, $g(x) = 3$

57) $h(x) = \sqrt{43x^2 + 36}$ 57) _____

A) $f(x) = \sqrt{43x + 36}$, $g(x) = x^2$ B) $f(x) = \sqrt{x}$, $g(x) = 43x^2 + 36$

C) $f(x) = \sqrt{43x^2}$, $g(x) = \sqrt{36}$ D) $f(x) = 43x^2 + 36$, $g(x) = \sqrt{x}$

Solve the problem.

58) Regrind, Inc. regrinds used typewriter platens. The cost to buy back each used platen is \$1.50. The fixed cost to run the grinding machine is \$376 per day. If the company sells the reground platens for \$5.50, how many must be reground daily

to break even? 58) _____

- A) 53 platens B) 62 platens C) 94 platens D) 250 platens

59) Northwest Molded molds plastic handles which cost \$0.50 per handle to mold. The fixed cost to run the molding machine is \$6408 per week. If the company sells the handles for \$3.50 each, how many handles must be molded weekly to break even? 59) _____

- A) 12,816 handles B) 1424 handles C) 1602 handles D) 2136 handles

60) Midtown Delivery Service delivers packages which cost \$1.70 per package to deliver. The fixed cost to run the delivery truck is \$90 per day. If the company charges \$7.70 per package, how many packages must be delivered daily to break even? 60) _____

- A) 52 packages B) 15 packages C) 10 packages D) 9 packages

61) A lumber yard has fixed costs of \$2248.00 a day and marginal costs of \$0.36 per board-foot produced. The company gets \$1.36 per board-foot sold. How many board-feet must be produced daily to break even? 61) _____

- A) 6244 board-feet B) 2248 board-feet
C) 1498 board-feet D) 1306 board-feet

62) Midtown Delivery Service delivers packages which cost \$2.40 per package to deliver. The fixed cost to run the delivery truck is \$205 per day. If the company charges \$7.40 per package, how many packages must be delivered daily to make a profit of \$80? 62) _____

- A) 57 packages B) 85 packages C) 20 packages D) 41 packages

63) The cost of manufacturing clocks is given by $C(x) = 55 + 36x - x^2$. Also, it is known that in t hours the number of clocks that can be produced is given by $x = 11t$, where $1 \leq t \leq 12$. Express C as a function of t . 63) _____

- A) $C(t) = 55 + 396t - 121t$ B) $C(t) = 55 + 36t + t^2$
C) $C(t) = 55 + 396t - 121t^2$ D) $C(t) = 55 + 36t - 11$

64) At Allied Electronics, production has begun on the X-15 Computer Chip. The total revenue function is given by $R(x) = 46x - 0.3x^2$ and the total cost function is given by $C(x) = 7x + 12$, where x represents the number of boxes of computer chips produced. The total profit function, $P(x)$, is such that $P(x) = R(x) - C(x)$. Find $P(x)$. 64) _____

- A) $P(x) = 0.3x^2 + 39x - 24$ B) $P(x) = -0.3x^2 + 32x + 12$
C) $P(x) = -0.3x^2 + 39x - 12$ D) $P(x) = 0.3x^2 + 32x - 36$

65) At Allied Electronics, production has begun on the X-15 Computer Chip. The total revenue function is given by $R(x) = 56x - 0.3x^2$ and the total profit function is given by $P(x) = -0.3x^2 + 48x - 14$, where x represents the number of boxes of computer chips produced. The total cost function, $C(x)$, is such that $C(x) = R(x) - P(x)$. Find $C(x)$. 65) _____

- A) $C(x) = 10x + 10$ B) $C(x) = 8x + 14$
C) $C(x) = -0.3x^2 + 16x + 14$ D) $C(x) = 9x + 19$

66) At Allied Electronics, production has begun on the X-15 Computer Chip. The total cost function is given by

$C(x) = 3x + 11$ and the total profit function is given by $P(x) = -0.3x^2 + 37x - 11$, where x represents the number of boxes of computer chips produced. The total revenue function, $R(x)$, is such that $R(x) = C(x) + P(x)$. Find $R(x)$. 66) _____

- A) $R(x) = 39x - 0.6x^2$ B) $R(x) = 42x - 0.3x^2$
 C) $R(x) = 40x - 0.3x^2$ D) $R(x) = 40x + 0.3x^2$

67) The radius r of a circle of known area A is given by $r = \sqrt{\frac{A}{\pi}}$, where $\pi \approx 3.1416$. Find the radius and circumference of a circle with an area of 6.32 sq ft. (Round results to two decimal places.) 67) _____

- A) $r = 1.42$ ft, $C = 8.92$ sq ft B) $r = 1.42$ ft, $C = 8.86$ ft
 C) $r = 1.42$ ft, $C = 8.92$ ft D) $r = 2.02$ ft, $C = 12.69$ ft

68) The volume of water added to a circular drum of radius r is given by $V_w = 35t$, where V_w is volume in cu ft and t is time in sec. Find the depth of water in a drum of radius 6 ft after adding water for 9 sec. (Round result to one decimal place.) 68) _____

- A) 2.8 ft B) 1.7 ft C) 5.6 ft D) 8.8 ft

69) A retail store buys 240 VCRs from a distributor at a cost of \$190 each plus an overhead charge of \$35 per order. The retail markup is 35% on the total price paid. Find the profit on the sale of one VCR. 69) _____

- A) \$6655.00 B) \$66.50 C) \$66.55 D) \$66.45

70) A balloon (in the shape of a sphere) is being inflated. The radius is increasing at a rate of 11 cm per second. Find a function, $r(t)$, for the radius in terms of t . Find a function, $V(r)$, for the volume of the balloon in terms of r . Find $(V \circ r)(t)$. 70) _____

- A) $(V \circ r)(t) = \frac{58564\pi\sqrt{t}}{3}$ B) $(V \circ r)(t) = \frac{5324\pi t^3}{3}$
 C) $(V \circ r)(t) = \frac{6655\pi t^2}{3}$ D) $(V \circ r)(t) = \frac{847\pi t^3}{3}$

71) A stone is thrown into a pond. A circular ripple is spreading over the pond in such a way that the radius is increasing at the rate of 2.4 feet per second. Find a function, $r(t)$, for the radius in terms of t . Find a function, $A(r)$, for the area of the ripple in terms of r . Find $(A \circ r)(t)$. 71) _____

- A) $(A \circ r)(t) = 5.76\pi t^2$ B) $(A \circ r)(t) = 2.4\pi t^2$
 C) $(A \circ r)(t) = 5.76\pi^2 t$ D) $(A \circ r)(t) = 4.8\pi t^2$

72) Ken is 6 feet tall and is walking away from a streetlight. The streetlight has its light bulb 14 feet above the ground, and Ken is walking at the rate of 4.6 feet per second. Find a function, $d(t)$, which gives the distance Ken is from the streetlight in terms of time. Find a function, $S(d)$, which gives the length of Ken's shadow in terms of d . Then find $(S \circ d)(t)$. 72) _____

- A) $(S \circ d)(t) = 3.45t$ B) $(S \circ d)(t) = 4.37t$ C) $(S \circ d)(t) = 7.77t$ D) $(S \circ d)(t) = 2.53t$

73) Ken is 6 feet tall and is walking away from a streetlight. The streetlight has its light bulb 14 feet above the ground, and Ken is walking at the rate of 3 feet per second. Find a function, $d(t)$, which gives the distance Ken is from the streetlight in

terms of time. Find a function, $S(d)$, which gives the length of Ken's shadow in terms of d . Then find $(S \circ d)(t)$. What is the meaning of $(S \circ d)(t)$? 73) _____

- A) $(S \circ d)(t)$ gives the length of Ken's shadow in terms of his distance from the streetlight.
- B) $(S \circ d)(t)$ gives the length of Ken's shadow in terms of time.
- C) $(S \circ d)(t)$ gives the distance Ken is from the streetlight in terms of time.
- D) $(S \circ d)(t)$ gives the time in terms of Ken's distance from the streetlight.

- 1) A
- 2) C
- 3) C
- 4) B
- 5) B
- 6) C
- 7) B
- 8) D
- 9) D
- 10) A
- 11) C
- 12) C
- 13) C
- 14) B
- 15) D
- 16) A
- 17) D
- 18) B
- 19) B
- 20) D
- 21) B
- 22) B
- 23) B
- 24) D
- 25) A
- 26) B
- 27) C
- 28) A
- 29) A
- 30) C
- 31) C
- 32) C
- 33) A
- 34) A
- 35) D
- 36) A
- 37) D
- 38) D
- 39) B
- 40) A
- 41) C
- 42) B
- 43) B
- 44) A
- 45) C
- 46) D
- 47) A
- 48) B
- 49) B
- 50) A
- 51) B

- 52) B
- 53) C
- 54) C
- 55) D
- 56) C
- 57) B
- 58) C
- 59) D
- 60) B
- 61) B
- 62) A
- 63) C
- 64) C
- 65) B
- 66) C
- 67) C
- 68) A
- 69) C
- 70) B
- 71) A
- 72) A
- 73) B