

Exam
Name _____

MULTIPLE CHOICE. Choose the one alternative that best completes the statement or answers the question.
The graph shows sales in thousands of dollars for 1989 and 1990. Use it to answer the question.

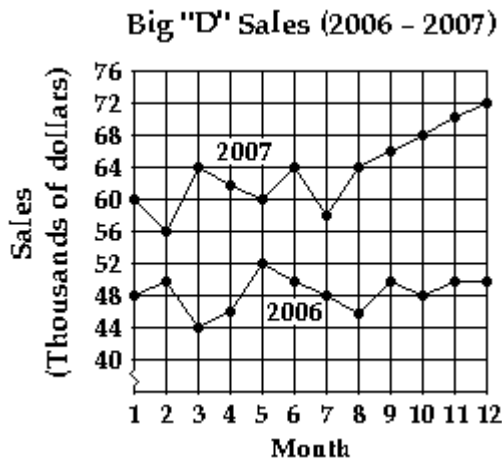

1) If the ordered pair (x, y) represents a point on the graph, what does x represent? What does y represent? 1) _____

- A) x represents the year 2006; y represents the sales in thousands of dollars
- B) x represents the month; y represents the sales in thousands of dollars.
- C) y represents the month; x represents the sales in thousands of dollars.
- D) x represents the year 2006; y represents the year 2007.

2) Estimate the sales in June 2006. 2) _____

- A) about \$52 thousand
- B) about \$64 thousand
- C) about \$50 thousand
- D) about \$48 thousand

3) Write an ordered pair (x, y) that gives approximately the sales in June 2006. 3) _____

- A) (2006, 50)
- B) (June, 50)
- C) (6, 50)
- D) (50, 6)

SHORT ANSWER. Write the word or phrase that best completes each statement or answers the question.

4) What does the ordered pair $(10, 48)$ for 2006 mean in the context of this graph? 4) _____

MULTIPLE CHOICE. Choose the one alternative that best completes the statement or answers the question.

5) Which month in 2006 had the lowest sales? 5) _____

- A) Month 6
- B) Month 3
- C) Month 8
- D) Month 2

6) Which month in 2007 had the highest sales? 6) _____

- A) Month 5
- B) Month 3
- C) Month 6
- D) Month 12

7) What month in 2006 had the highest sales? 7) _____

- A) Month 5
- B) Month 12
- C) Month 2
- D) Month 3

8) What month in 2007 had the lowest sales? 8) _____

- A) Month 5
- B) Month 12
- C) Month 3
- D) Month 2

Name the quadrant, if any, in which the point is located.

9) $(5, 18)$ 9) _____

- A) III
- B) None
- C) I
- D) II

10) (-11, 18) 10) _____
A) II B) III C) None D) I

11) (-7, -18) 11) _____
A) IV B) None C) II D) III

12) (9, -13) 12) _____
A) I B) II C) III D) IV

13) (-10, 0) 13) _____
A) IV B) II C) III D) None

14) (0, -10) 14) _____
A) II B) IV C) III D) None

Plot the point on the rectangular coordinate system provided. Write the corresponding letter as your answer.

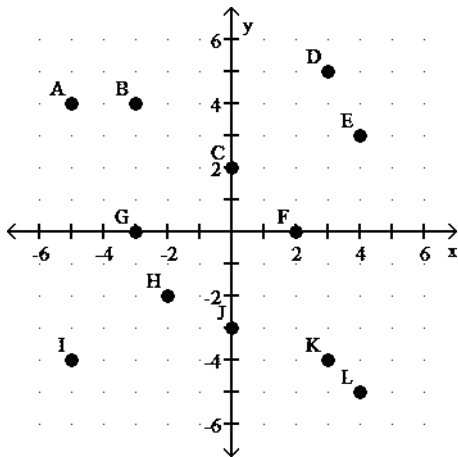

15) (0, 2) 15) _____
A) C B) B C) K D) F

16) (-5, -4) 16) _____
A) L B) A C) G D) I

17) (-3, 4) 17) _____
A) A B) K C) B D) F

18) (-3, 0) 18) _____
A) G B) F C) J D) C

19) (3, 5) 19) _____
A) L B) D C) K D) I

20) (4, 3) 20) _____
A) E B) D C) C D) K

21) (0, -3) 21) _____
A) I B) G C) J D) C

22) (2, 0) 22) _____

A) F B) B C) C D) K

23) (4, -5) 23) _____

A) F B) K C) L D) A

Complete the table for the equation.

24) $x + y = 8$

x	y
5	
8	
0	

24) _____

A) 3; 0; 8 B) 3; 2; 8 C) 15; 0; 8 D) 5; 8; 0

25) $y = -x - 10$

x	y
-8	
-10	
0	

25) _____

A) -10; -2; -10 B) -2; 0; -10 C) -2; 0; 0 D) -10; 0; -10

26) $5x + y = -10$

x	y
-3	
-10	
0	

26) _____

A) 5; 40; -10 B) -10; 40; 40 C) 5; 40; 40 D) -10; -10; -10

27) $y + 5x = -27$

x	y
-7	
108	
0	

27) _____

A) 8; -27; -27 B) 8; -108; 108 C) 8; -27; 0 D) -7; -27; -27

28) $y = -8x - 16$

x	y
-3	
0	
	-24

28) _____

A) 8; 0; 1 B) 8; -32; 1 C) -3; -16; 1 D) 8; -16; 1

29) $x + 4y = 12$

x	y
4	
0	
-4	

29) _____

- A) -2; -3; -4 B) 0; 4; 8 C) 4; 3; 2 D) 2; 3; 4

30) $-4x - 4y = -8$

x	y
	2
-4	
	-2

30) _____

- A) 0; -6; 4 B) 0; -4; -6 C) 0; 4; 6 D) 0; 6; 4

Graph the equation by determining the missing values needed to plot the ordered pairs.

31) $y + x = 4$; (1,), (4,), (3,)

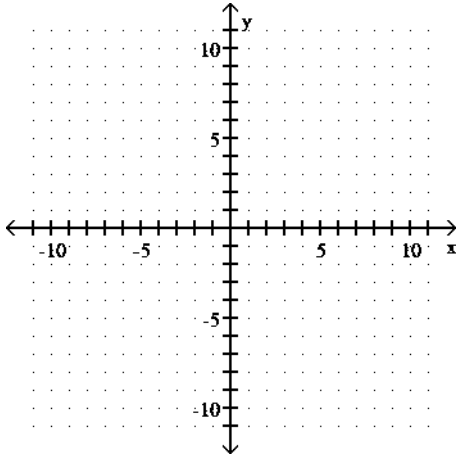

31) _____

A)

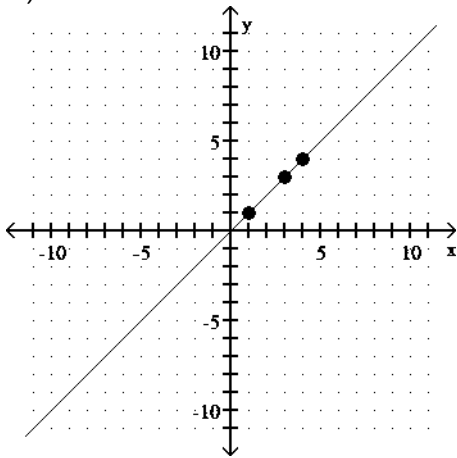

B)

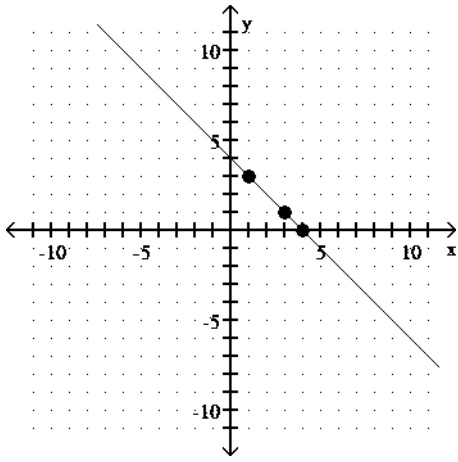

C)

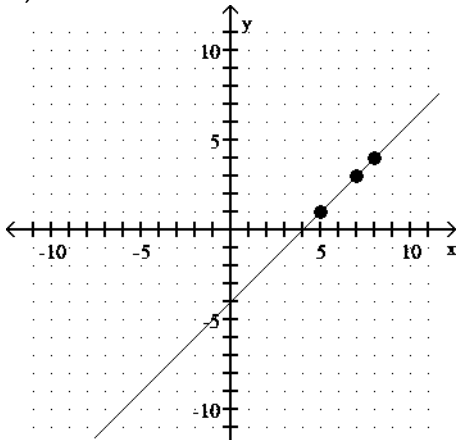

D)

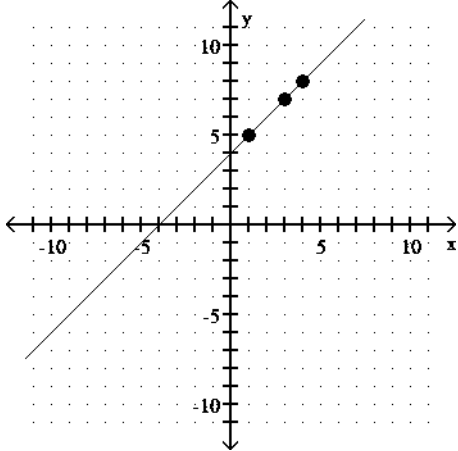

32) $y - x = 2$; (2,), (, 8), (4,)

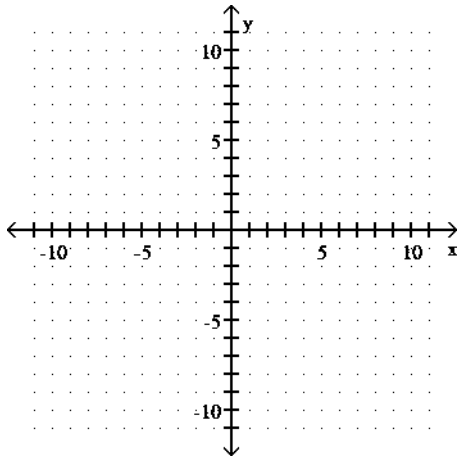

32) _____

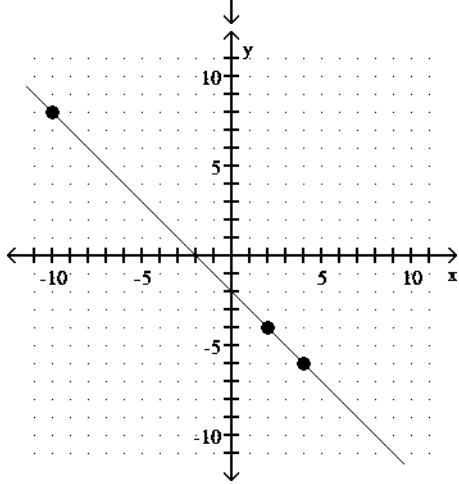
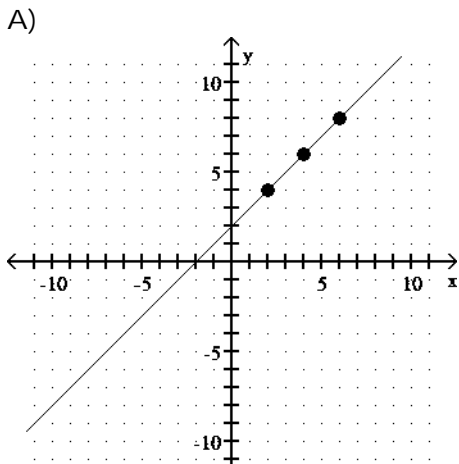

C)

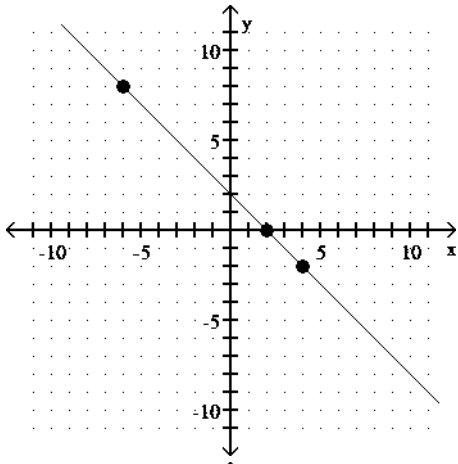

D)

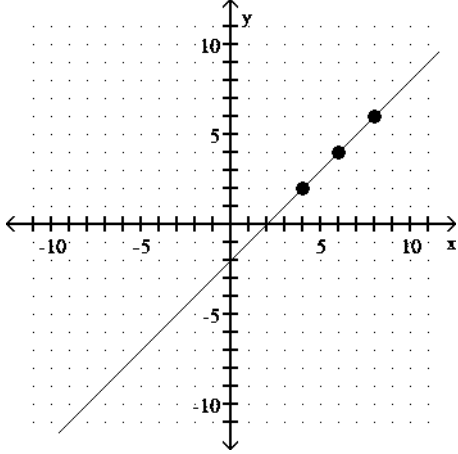

33) $x - 2y = -6$; $(0, \quad)$, $(\quad, 0)$, $(2, \quad)$, $(\quad, 2)$

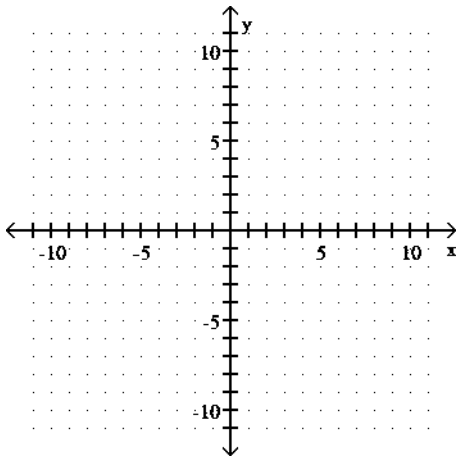

33) _____

A)

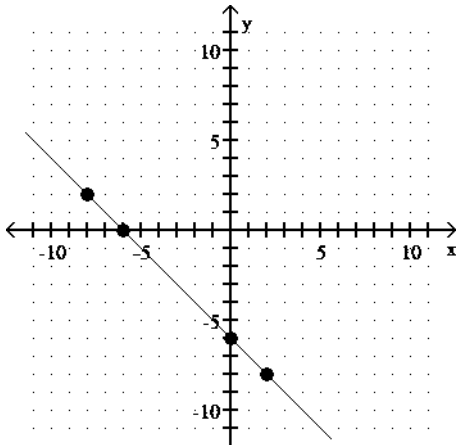

B)

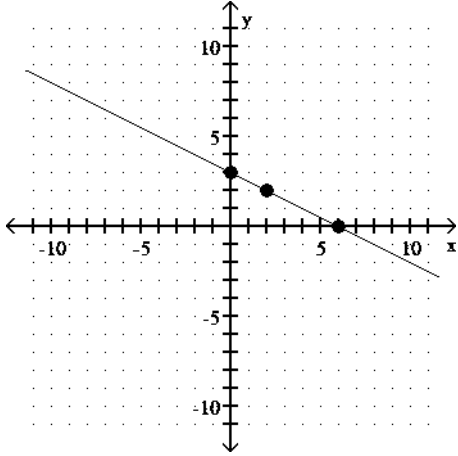

C)

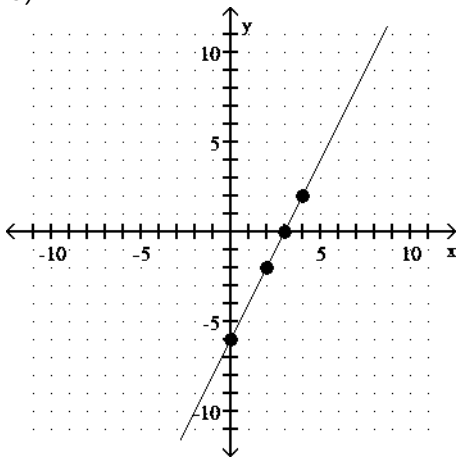

D)

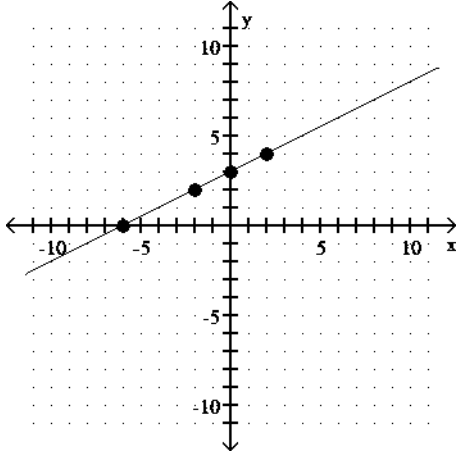

34) $4x - 5y = -20$; $(0, \quad)$, $(\quad, 0)$, $(-2, \quad)$, $(\quad, 3)$

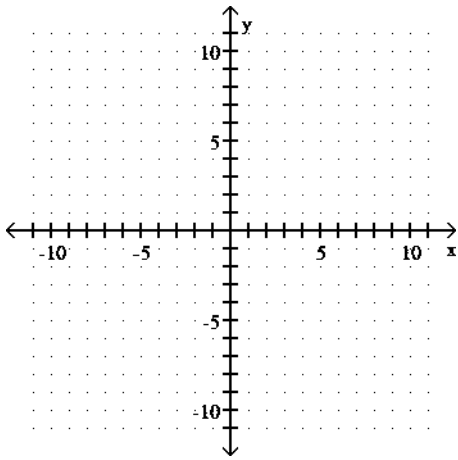

34) _____

A)

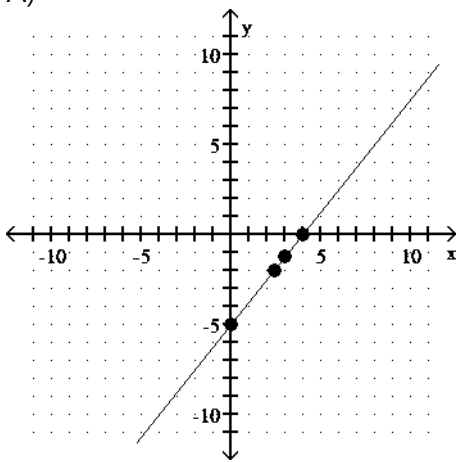

B)

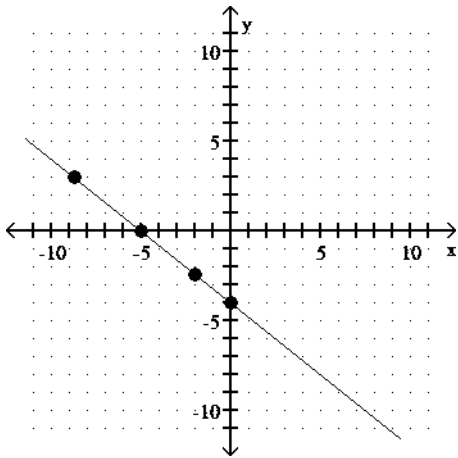

C)

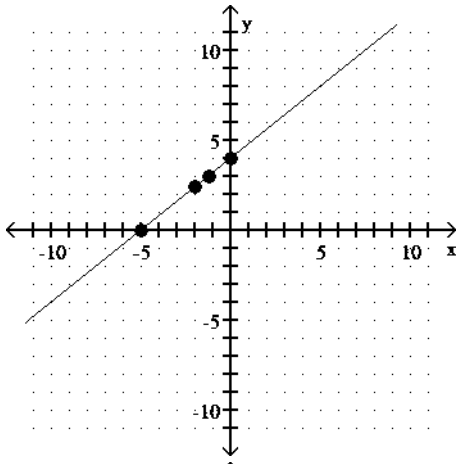

D)

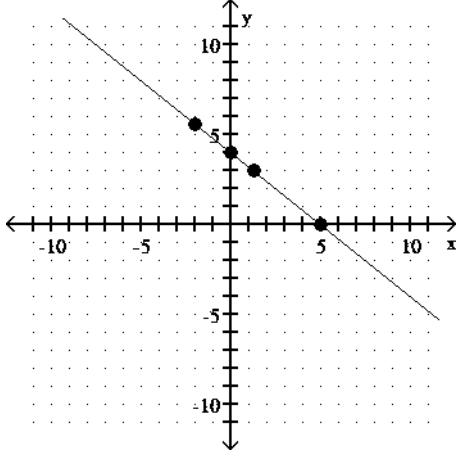

Find the x- and y-intercepts. Then graph the equation.

35) $8y - 2x = -4$

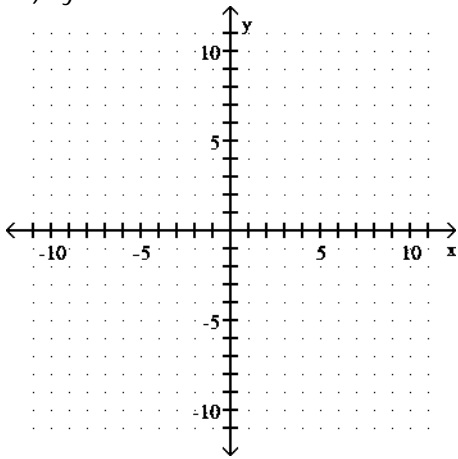

35) _____

A) $(2, 0); \left(0, -\frac{1}{2}\right)$

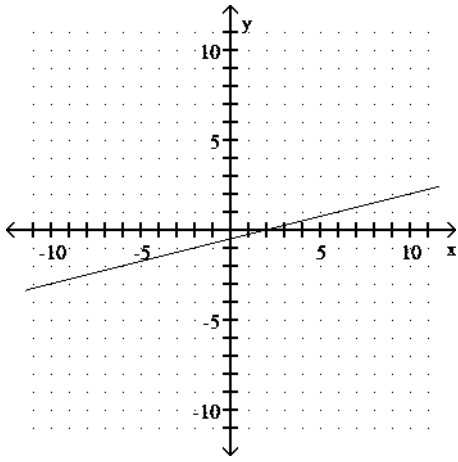

B) $\left(-\frac{1}{2}, 0\right); (0, 2)$

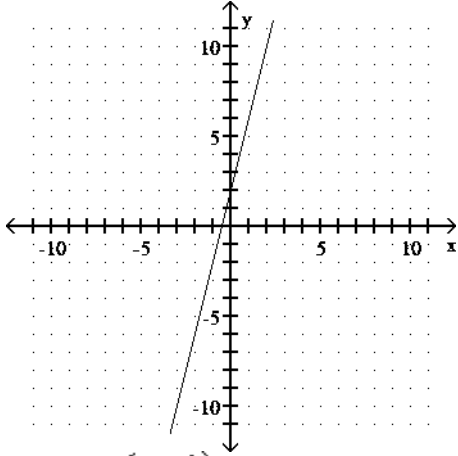

C) $(-2, 0); \left(0, -\frac{1}{2}\right)$

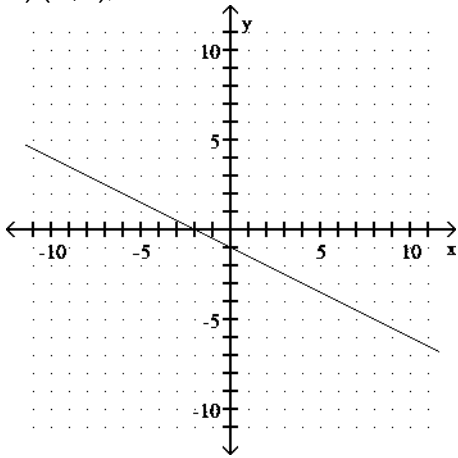

D) $\left(-\frac{1}{2}, 0\right); (0, -2)$

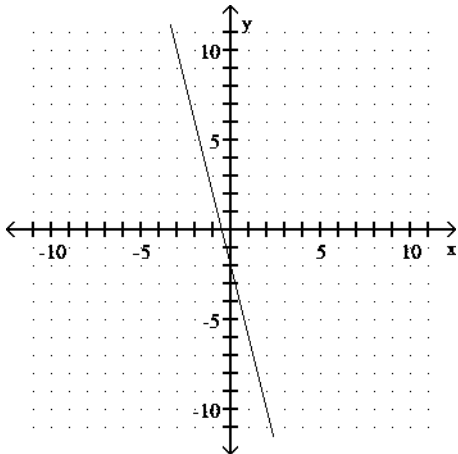

36) $-4x - 12y = 24$

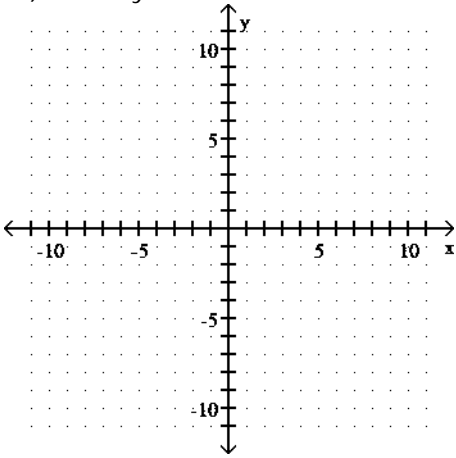

36) _____

A) $(-2, 0); (0, -6)$

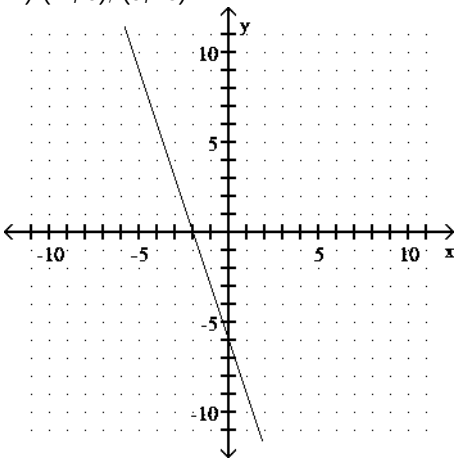

B) $(-6, 0); (0, -2)$

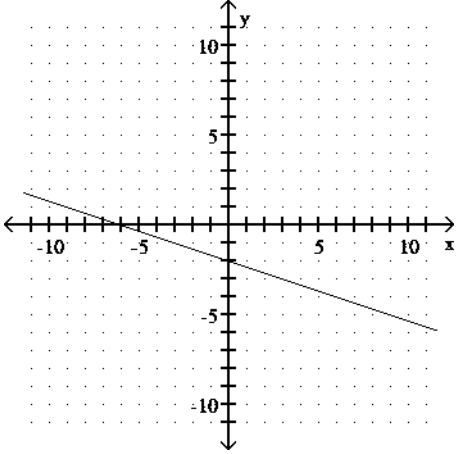

C) $(-2, 0); (0, 6)$

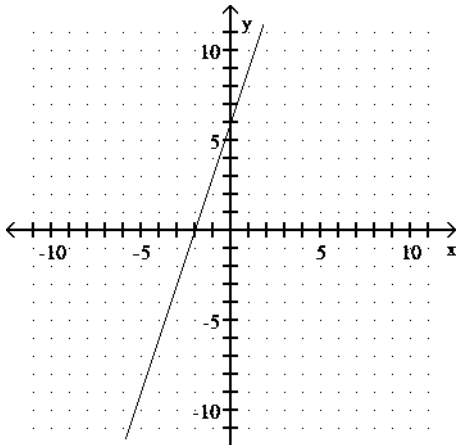

D) (6, 0); (0, -2)

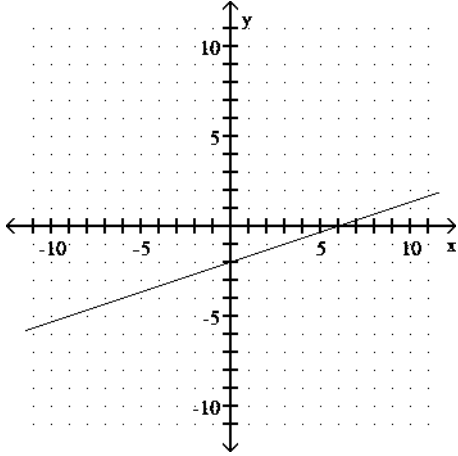

37) $y = -5$

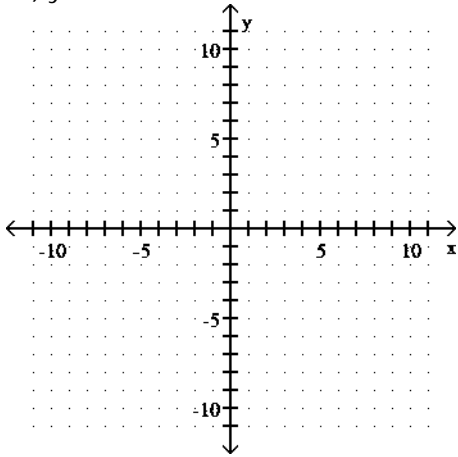

37) _____

A) None; (0, -5)

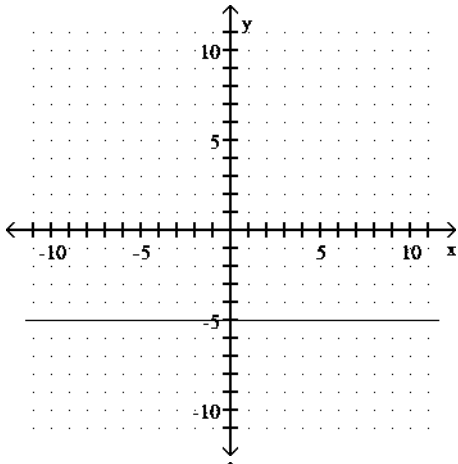

B) $(-5, 0)$; none

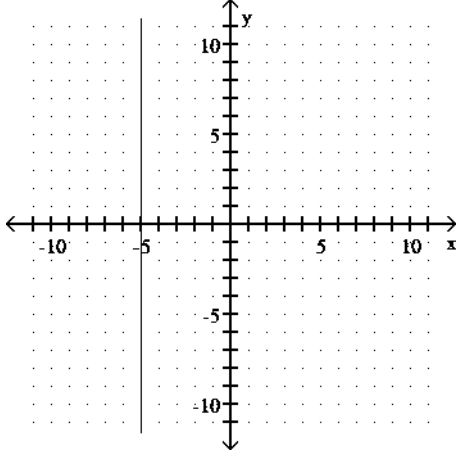

C) $(-5, 0)$; none

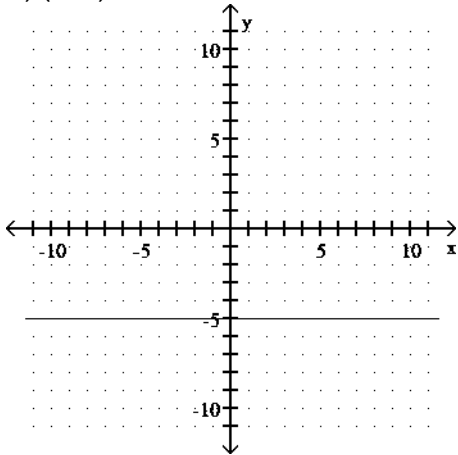

D) None; $(0, -5)$

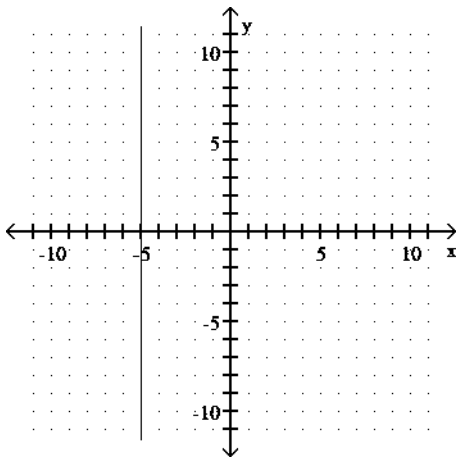

38) $4x - 16y = 16$

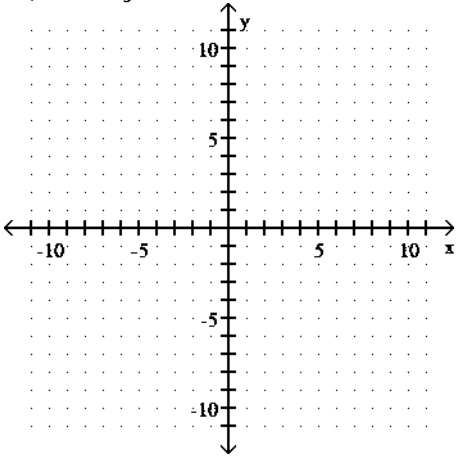

38) _____

A) $(-1, 0); (0, 4)$

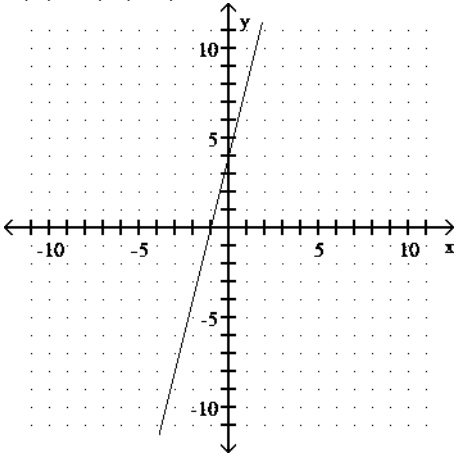

B) $(1, 0); (0, -4)$

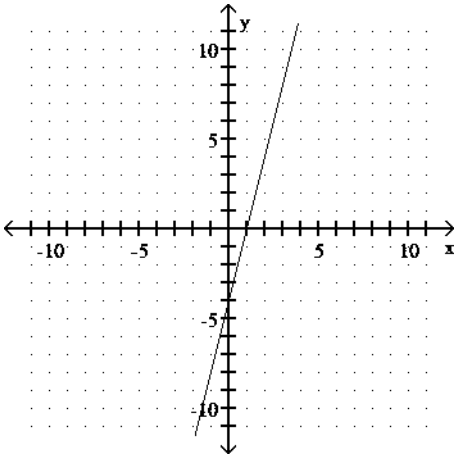

C) $(4, 0); (0, -1)$

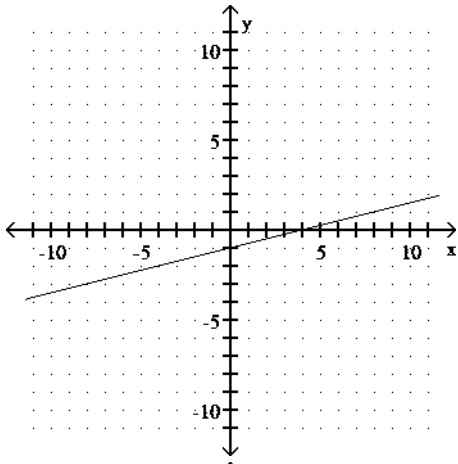

D) $(-4, 0); (0, 1)$

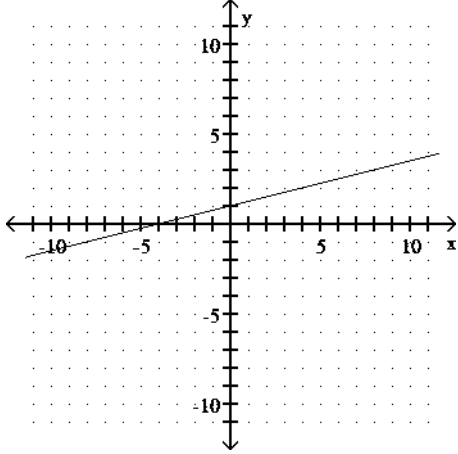

39) $2x - 6y = 0$

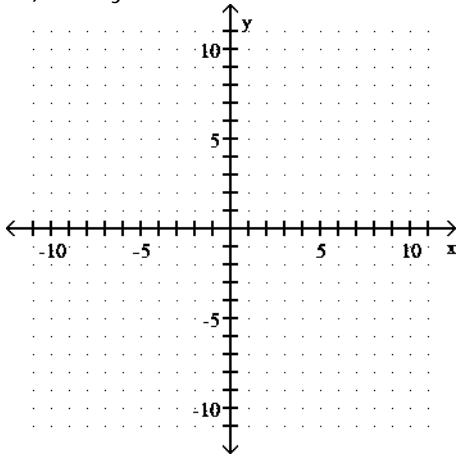

39) _____

A) $(0, 0); (0, 0)$

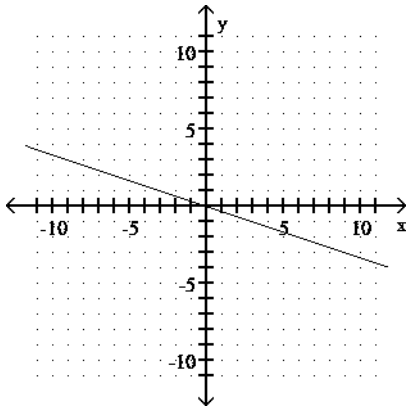

B) (0, 0); (0, 0)

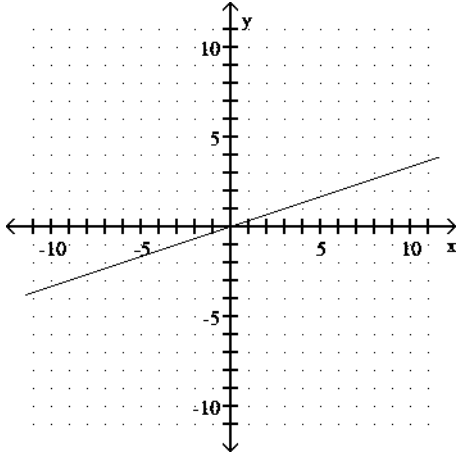

C) (0, 0); (0, 0)

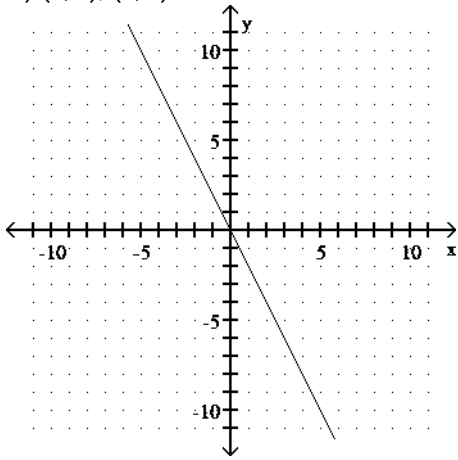

D) (0, 0); (0, 0)

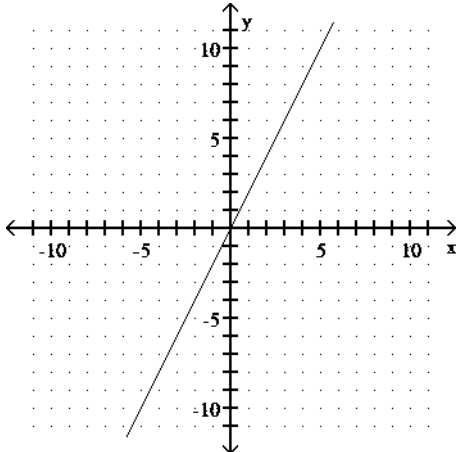

40) $\frac{11}{5}x + \frac{1}{5}y = 1$

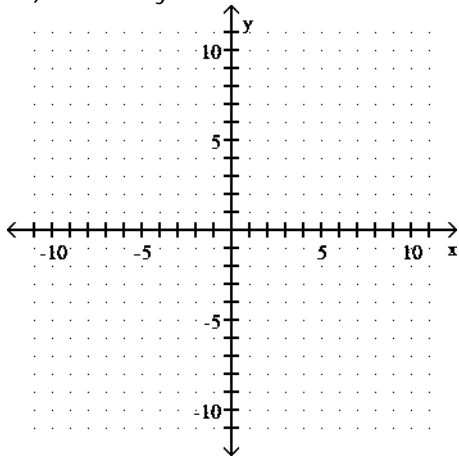

40) _____

A) $\left(\frac{5}{11}, 0\right); (0, 5)$

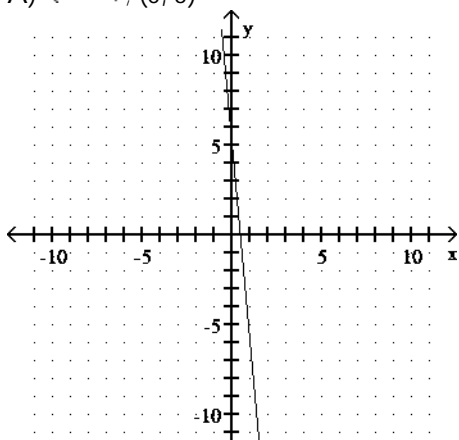

B) $\left(-\frac{5}{11}, 0\right); (0, -5)$

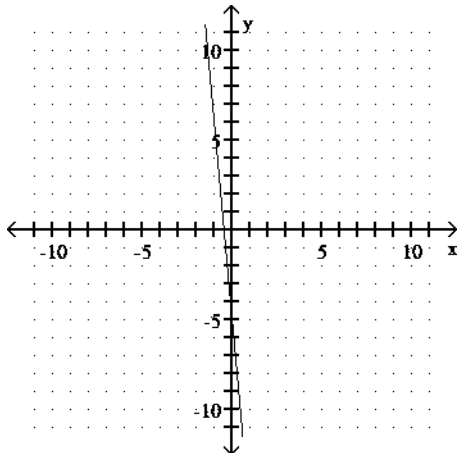

C) $\left(\frac{5}{11}, 0\right); (0, -5)$

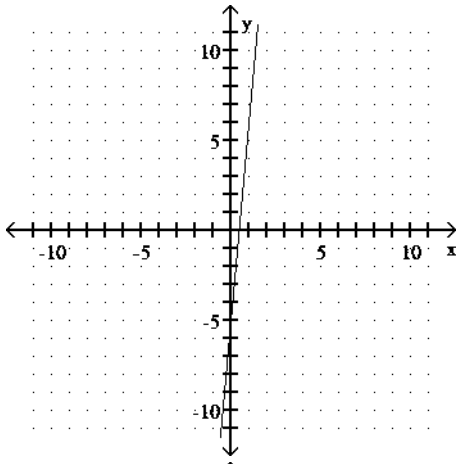

D) $\left(-\frac{5}{11}, 0\right); (0, 5)$

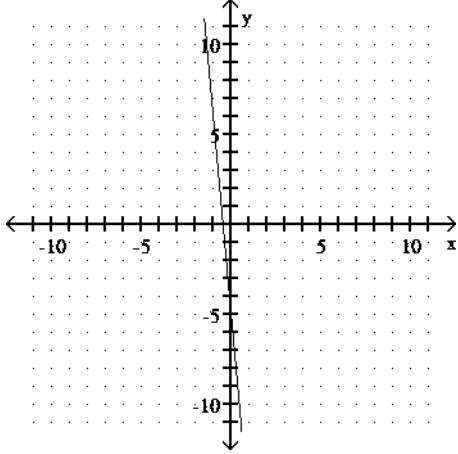

41) $2y = \frac{3}{5}x$

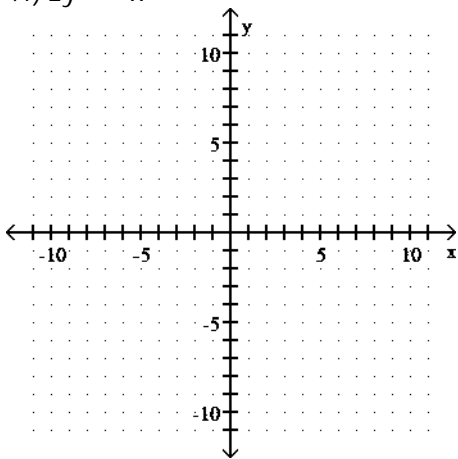

41) _____

A) $(0, 0); (0, 0)$

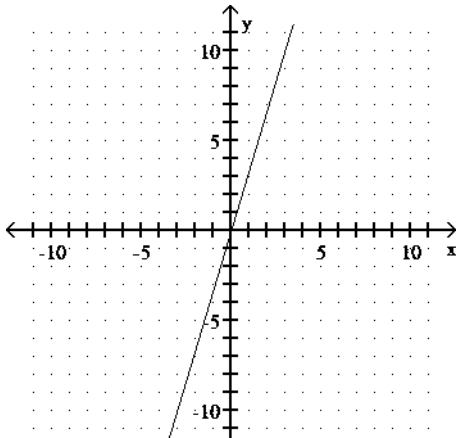

B) $(0, 0); (0, 0)$

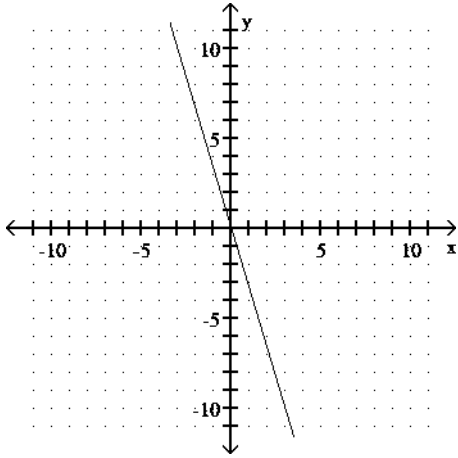

C) $(0, 0); (0, 0)$

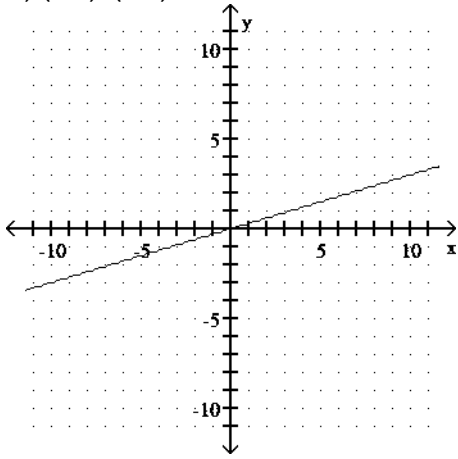

D) $(0, 0); (0, 0)$

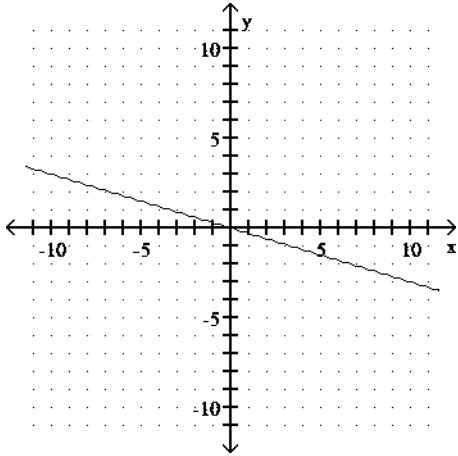

42) $x = 3$

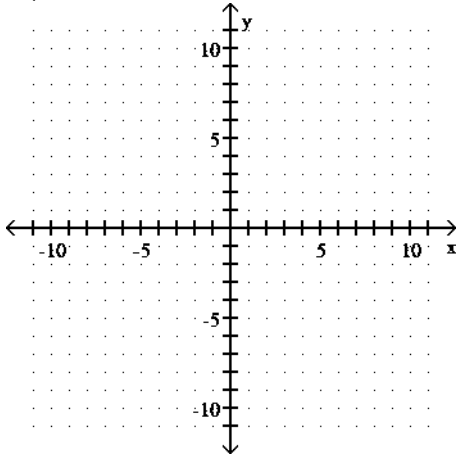

42) _____

A) (3, 0); none

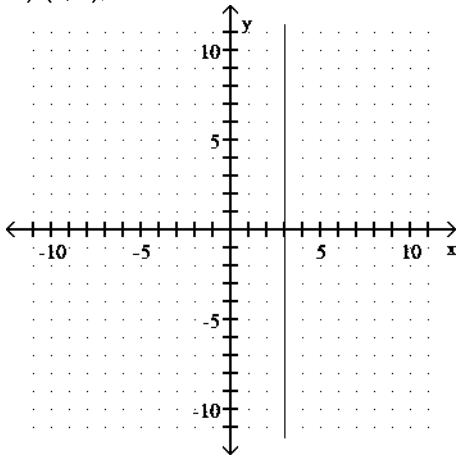

B) None; (0, 3)

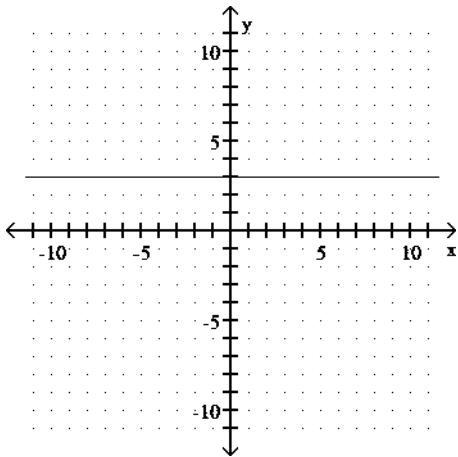

C) (3, 0); none

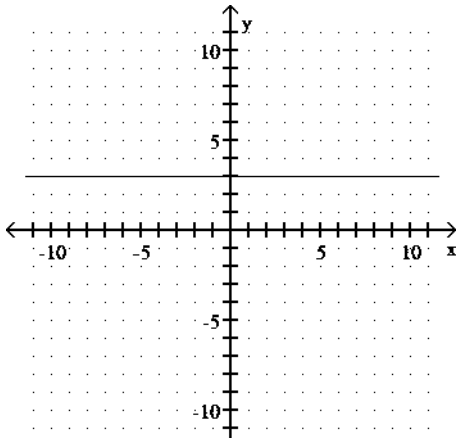

D) None; (0, 3)

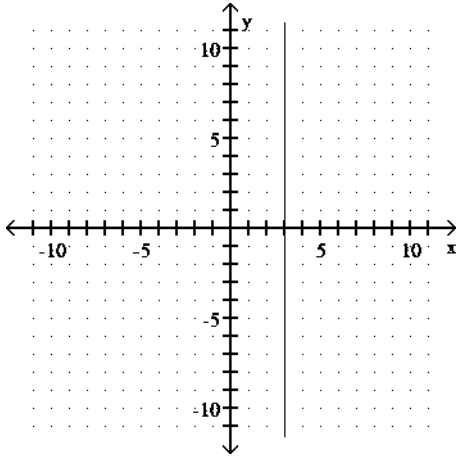

Find the midpoint of the segment with the given endpoints.

43) (1, 9) and (5, 1) 43) _____

- A) $(-4, 8)$ B) $(3, 5)$ C) $(6, 10)$ D) $(-2, 4)$

44) (8, -8) and (-3, 4) 44) _____

- A) $(5, -4)$ B) $(11, -12)$ C) $\left(\frac{5}{2}, -2\right)$ D) $\left(\frac{11}{2}, -6\right)$

45) (-6, -3) and (8, 3) 45) _____

- A) $(-14, -6)$ B) $(2, 0)$ C) $(1, 0)$ D) $(-7, -3)$

46) (-2, 3) and (9, 1) 46) _____

- A) $\left(-\frac{11}{2}, 1\right)$ B) $\left(\frac{7}{2}, 2\right)$ C) $(7, 4)$ D) $(-11, 2)$

47) $\left(-\frac{5}{2}, -\frac{5}{2}\right)$ and $\left(\frac{11}{2}, \frac{11}{2}\right)$ 47) _____

- A) $(256, 256)$ B) $(36, 36)$ C) $(-4, -4)$ D) $\left(\frac{3}{2}, \frac{3}{2}\right)$

48) (2.3, 6.6) and (6.2, -7.7) 48) _____

- A) $(-39, 143)$ B) $(-195, 7.15)$ C) $(8.5, -1.1)$ D) $(4.25, -0.55)$

Suppose that segment PQ has the given coordinates for one endpoint P and for its midpoint M. Find the coordinates of the other endpoint Q.

49) P(3, 8) and M($\frac{11}{2}, \frac{15}{2}$) 49) _____

A) Q(11, 15) B) Q(-5, 1) C) Q($-\frac{5}{2}, \frac{1}{2}$) D) Q(8, 7)

50) P(5, -3) and M($\frac{5}{2}, 1$) 50) _____

A) Q(0, 5) B) Q(5, -8) C) Q($\frac{5}{2}, -4$) D) Q(5, 2)

51) P(1, 1) and M($-\frac{1}{2}, -\frac{7}{2}$) 51) _____

A) Q(-2, -8) B) Q(-1, -7) C) Q($-\frac{3}{2}, -\frac{9}{2}$) D) Q(-3, -9)

52) P(-3, -9) and M(-1, -2) 52) _____

A) Q(4, 14) B) Q(1, 5) C) Q(2, 7) D) Q(-2, -4)

53) P($\frac{9}{2}, \frac{5}{2}$) and M(1, 0) 53) _____

A) Q($-\frac{5}{2}, -\frac{5}{2}$) B) Q(16, 0) C) Q($\frac{7}{2}, \frac{5}{2}$) D) Q(196, 100)

54) P(-7.2, -0.6) and M(-2, 1.1) 54) _____

A) Q(-4, 2.2) B) Q(-5.2, -1.7) C) Q(-10.4, -3.4) D) Q(3.2, 2.8)

Solve the problem.

55) The graphing calculator screen shows the graph of one of the equations below. Which equation is it?

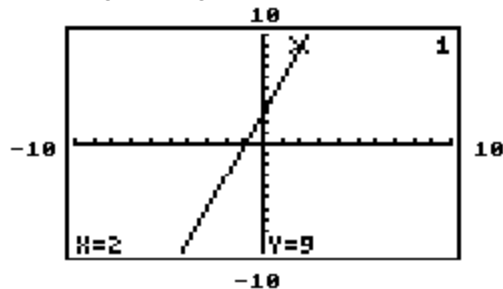

55) _____

A) $y + 3x = 15$ B) $y = 3x + 3$ C) $y + 3x = 3$ D) $y - 3x = 15$

56) The graphing calculator screen shows the graph of one of the equations below. Which equation is it?

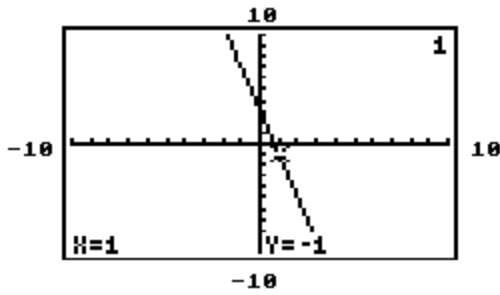

56) _____

- A) $y - 4x = -5$ B) $y + 4x = -5$ C) $y = -4x + 3$ D) $y - 4x = 3$

57) The graphing calculator screen shows the graph of one of the equations below. Which equation is it?

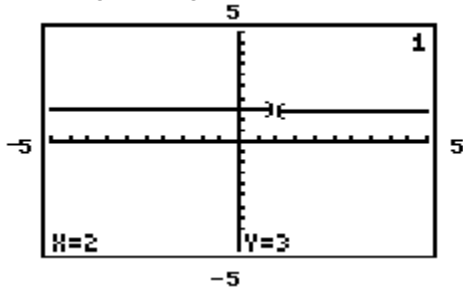

57) _____

- A) $y - x = 1$ B) $x + y = 5$ C) $x - y = -1$ D) $y = 3$

58) The graphing calculator screens show the graph of one of the equations below. Which equation is it?

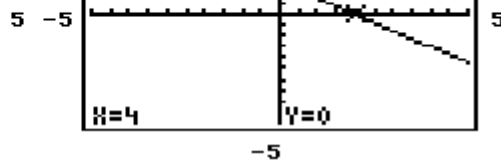
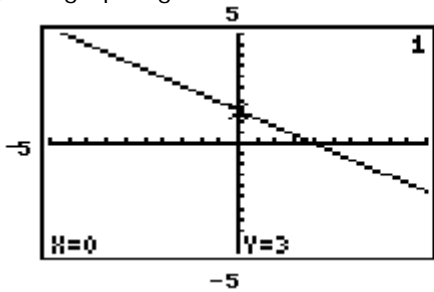

58) _____

- A) $3x - 4y = 12$ B) $3x - 4y = -12$ C) $-3x + 4y = 12$ D) $3x + 4y = 12$

59) The graphing calculator screens show the graph of one of the equations below. Which equation is it?

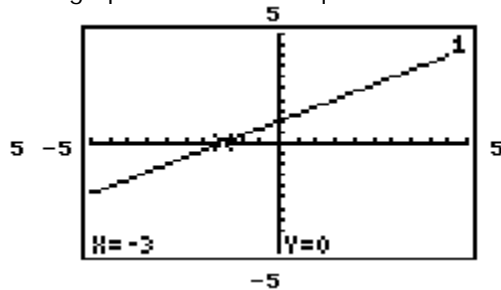
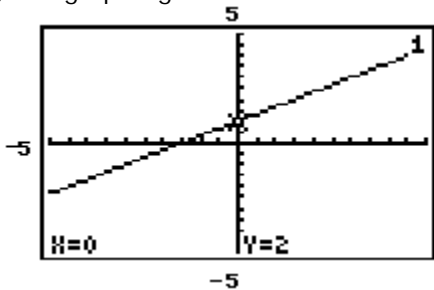

59) _____

- A) $-2x + 3y = 6$ B) $2x - 3y = 6$ C) $3x - 2y = -6$ D) $-2x + 3y = -6$

60) The table of ordered pairs was generated by a graphing calculator with a table feature. Which equation corresponds to this table of values?

X	Y1	
0.00	5.00	
1.00	9.00	
-2.00	-3.00	
2.00	13.00	

X=0

60) _____

- A) $y = 4x - 5$ B) $y = -4x + 5$ C) $y = -4x - 5$ D) $y = 4x + 5$
 1 1 1 1

61) The table of ordered pairs was generated by a graphing calculator with a table feature. Which equation corresponds to this table of values?

X	Y1	
2.00	-2.00	
6.00	0.00	
-2.00	-4.00	
4.00	-1.00	

X=2

61) _____

- A) $y_1 = \frac{1}{2}x + 3$ B) $y_1 = -\frac{1}{2}x - 3$ C) $y_1 = \frac{1}{2}x - 3$ D) $y_1 = -\frac{1}{2}x + 3$

62) Suppose that it has been determined that if 100 of a certain fish are introduced into a pond with certain environmental conditions, then in x months, there will be $y = 4.35x + 100$ fish in the pond. A portion of the graph of this equation is shown on the accompanying screen, along with the coordinates of a point on the line. How can this point be interpreted in the context of the model?

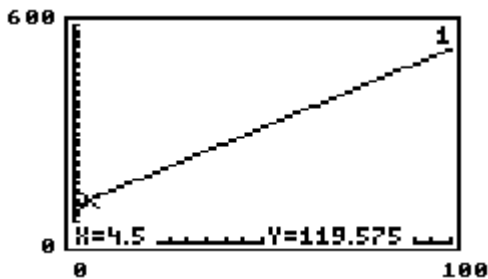

62) _____

- A) It means that in 4.5 months, there should be approximately 120 fish in the pond
 B) It means that there could be between 5 and 120 fish in the pond at a certain time
 C) It means that in 119.6 months, there should be approximately 5 fish in the pond
 D) It means that there will be fish in the pond in 4.5 months and in 119.6 months

63) Suppose that the speed at which an experienced person can paddle a canoe upstream is approximated by $y = -2.5x + 15$ ($0 < x < 6$), where x is the number of hours paddled and y is the speed of the canoe in miles per hour. A portion of the graph of this equation is shown on the accompanying screen, along with the coordinates of a point on the line. How can this point be interpreted in the context of the model?

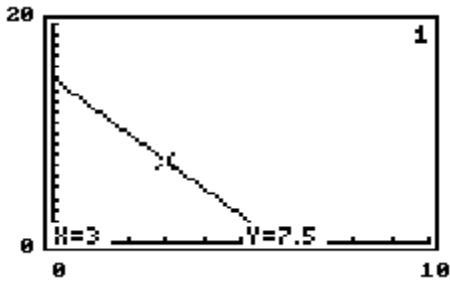

63) _____

- A) It means that the canoe can travel at a speed of between 3 and 7.5 miles per hour
- B) It means that after 3 hours of paddling, the canoe is traveling at a speed of 7.5 miles per hour.
- C) It means that an experienced person can paddle between 3 and 7.5 hours.
- D) It means that after 7.5 hours of paddling, the canoe is traveling at a speed of 3 miles per hour.

64) The winning speeds for the Grayslake 250 race from 1980-1992 are approximated by the linear equation $y = 2.503x + 198.729$. In the model, $x = 0$ corresponds to 1980, $x = 1$ to 1981, and so on. A portion of the graph of the equation is shown on the accompanying screen, along with the coordinates of a point on the line. How can this point be interpreted in the context of the model?

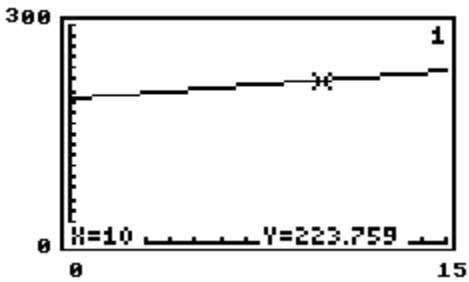

64) _____

- A) It means that in the year 1990, the winning speed was approximately 224 miles per hour.
- B) It means that the winning speed in the year 1990 will be the same as in the year 2203.
- C) It means that 10 years from now, the winning speed will be approximately 224 miles per hour.
- D) It means that the winning speed was between 10 and 224 miles per hour.

SHORT ANSWER. Write the word or phrase that best completes each statement or answers the question. Provide an appropriate response.

- 65) The point with coordinates (0, 0) is called the _____. 65) _____
- 66) For any value x , the point $(x, 0)$ lies on the ____ axis. 66) _____
- 67) To find the y -intercept of a line we let ____ = 0 and solve for _____. 67) _____
- 68) The equation ____ = 1 has a vertical line as its graph. 68) _____
- 69) To graph a straight line, we must find a minimum of ____ points. 69) _____

MULTIPLE CHOICE. Choose the one alternative that best completes the statement or answers the question.

- 70) Determine the quadrants in which the given point (x, y) may lie when $xy < 0$. 70) _____
 A) I or III B) II or IV C) II or III D) I or II
- 71) Determine the quadrants in which the given point (x, y) may lie when $x < 0$. 71) _____
 A) II or IV B) I or IV C) II or III D) III or IV

- 1) B
- 2) C
- 3) C
- 4) In October 2006, the sales were about \$48 thousand.
- 5) B
- 6) D
- 7) A
- 8) D
- 9) C
- 10) A
- 11) D
- 12) D
- 13) D
- 14) D
- 15) A
- 16) D
- 17) C
- 18) A
- 19) B
- 20) A
- 21) C
- 22) A
- 23) C
- 24) A
- 25) B
- 26) A
- 27) A
- 28) D
- 29) D
- 30) D
- 31) B
- 32) A
- 33) D
- 34) C
- 35) A
- 36) B
- 37) A
- 38) C
- 39) B
- 40) A
- 41) C
- 42) A
- 43) B
- 44) C
- 45) C
- 46) B
- 47) D
- 48) D
- 49) D
- 50) A
- 51) A

- 52) B
- 53) A
- 54) D
- 55) B
- 56) C
- 57) D
- 58) D
- 59) A
- 60) D
- 61) C
- 62) A
- 63) B
- 64) A
- 65) origin
- 66) x
- 67) x, y
- 68) x
- 69) two
- 70) B
- 71) C

Exam

Name _____

MULTIPLE CHOICE. Choose the one alternative that best completes the statement or answers the question.

Find the slope.

$$1) m = \frac{7-3}{7-5} \quad 1) \text{ _____}$$

- A) 6 B) 5 C) 2 D) -2

$$2) m = \frac{4-6}{-6-4} \quad 2) \text{ _____}$$

- A) -1 B) 1 C) $-\frac{1}{5}$ D) $\frac{1}{5}$

$$3) m = \frac{5-(-1)}{-7-(-4)} \quad 3) \text{ _____}$$

- A) $-\frac{2}{3}$ B) -2 C) $-\frac{4}{3}$ D) 2

$$4) m = \frac{-4-(-4)}{7-4} \quad 4) \text{ _____}$$

- A) Undefined B) $-\frac{8}{3}$ C) $\frac{8}{3}$ D) 0

$$5) m = \frac{10-6}{-9-(-9)} \quad 5) \text{ _____}$$

- A) 4 B) 0 C) $-\frac{2}{9}$ D) Undefined

$$6) m = \frac{2-(-3)}{-2-(-6)} \quad 6) \text{ _____}$$

- A) $-\frac{1}{4}$ B) $\frac{5}{4}$ C) $\frac{5}{16}$ D) $-\frac{5}{4}$

$$7) m = \frac{6-1}{9-4} \quad 7) \text{ _____}$$

- A) 0 B) $\frac{7}{5}$ C) Undefined D) 1

$$8) m = \frac{4-(-9)}{9-(-4)} \quad 8) \text{ _____}$$

A) Undefined B) -1 C) 0 D) 1

Find the slope of the line through the given pair of points, if possible. Based on the slope, indicate whether the line through the points rises from left to right, falls from left to right, is horizontal, or is vertical.

9) (7, -4) and (-6, -9) 9) _____

A) $-\frac{13}{5}$; falls B) $\frac{5}{13}$; rises C) $\frac{13}{5}$; rises D) $-\frac{5}{13}$; falls

10) (9, -5) and (4, 6) 10) _____

A) $\frac{11}{5}$; rises B) $-\frac{11}{5}$; falls C) $-\frac{5}{11}$; falls D) $\frac{5}{11}$; rises

11) (6, -6) and (6, 7) 11) _____

A) 0; horizontal B) 13; rises
C) -13; falls D) Undefined; vertical

12) (-2, -5) and (-8, -5) 12) _____

A) 6; rises B) -6; falls
C) 0; horizontal D) Undefined; vertical

13) (1.1, 3.3) and (-0.9, -4.5) 13) _____

A) $-\frac{39}{10}$; falls B) $-\frac{10}{39}$; falls C) $\frac{39}{10}$; rises D) $\frac{10}{39}$; rises

14) (-3.4, -0.1) and (-2.6, -0.7) 14) _____

A) $\frac{3}{4}$; rises B) $-\frac{4}{3}$; falls C) $-\frac{3}{4}$; falls D) $\frac{4}{3}$; rises

15) $\left(\frac{1}{2}, \frac{6}{5}\right)$ and $\left(\frac{5}{6}, \frac{7}{5}\right)$ 15) _____

A) $\frac{5}{6}$; rises B) $\frac{3}{5}$; rises C) $\frac{5}{12}$; rises D) $\frac{5}{6}$; falls

Find the slope of the line.

16)

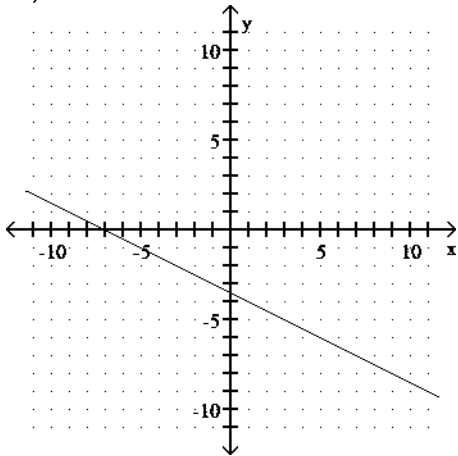

16) _____

- A) -2 B) $-\frac{1}{2}$ C) $\frac{1}{2}$ D) 2

17)

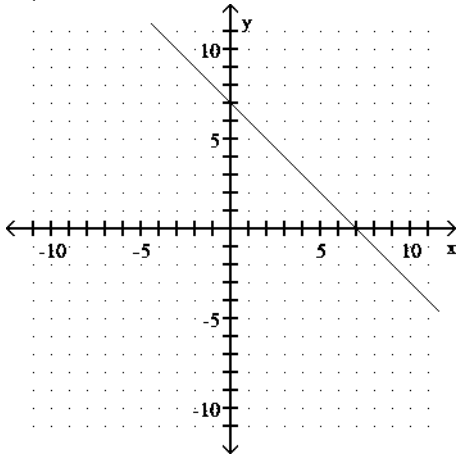

17) _____

- A) 7 B) -7 C) -1 D) 1

18)

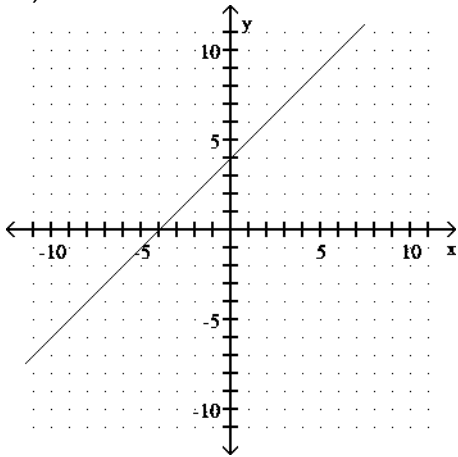

18) _____

- A) -1 B) 1 C) -4 D) 4

19)

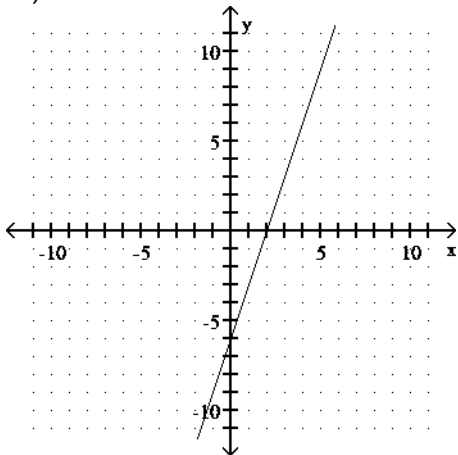

19) _____

- A) $\frac{1}{3}$ B) $-\frac{1}{3}$ C) 3 D) -3

20)

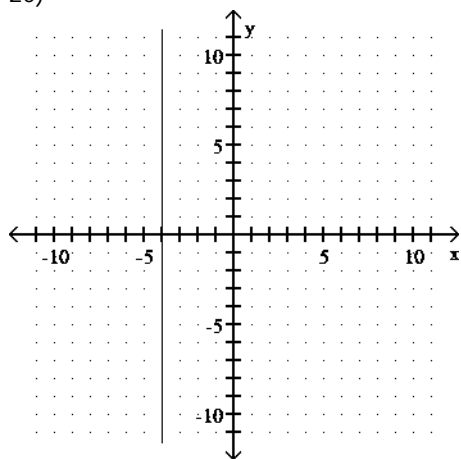

20) _____

- A) -4 B) Undefined C) $\frac{3}{2}$ D) 0

21)

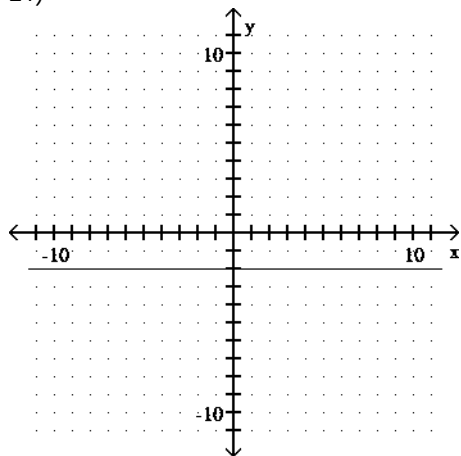

21) _____

- A) 0 B) 2 C) -2 D) Undefined

Find the slope of the line and sketch the graph.

22) $2x + 3y = 10$

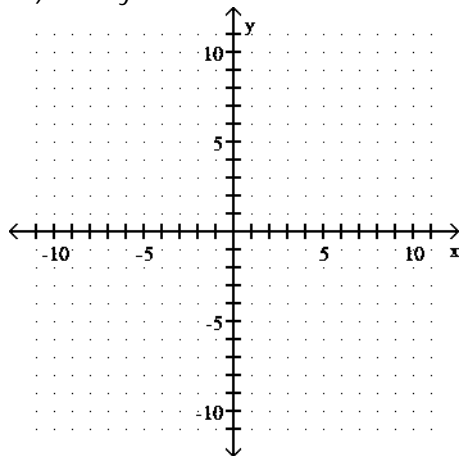

22) _____

A) Slope: $\frac{3}{2}$

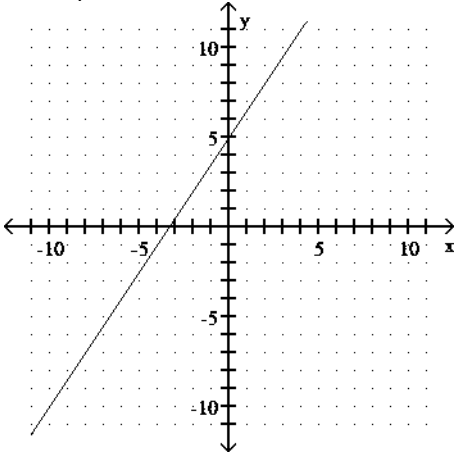

B) Slope: $-\frac{2}{3}$

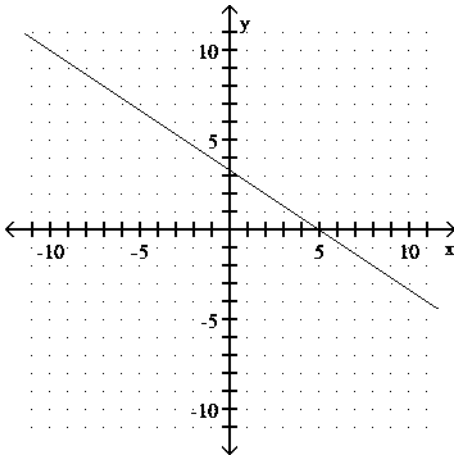

C) Slope: $\frac{2}{3}$

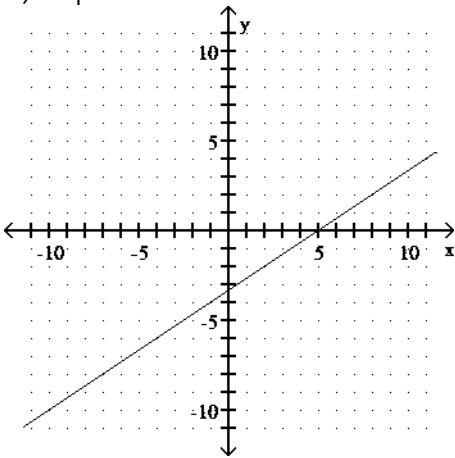

D) Slope: $-\frac{3}{2}$

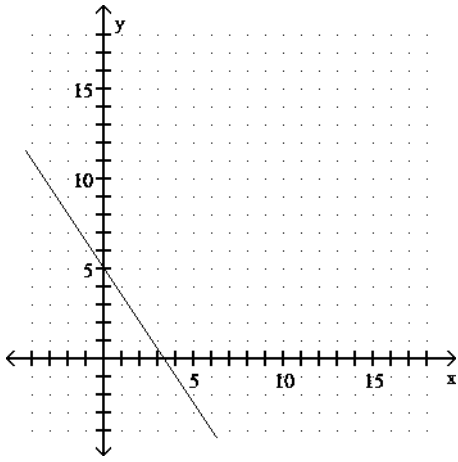

23) $2x - 3y = -5$

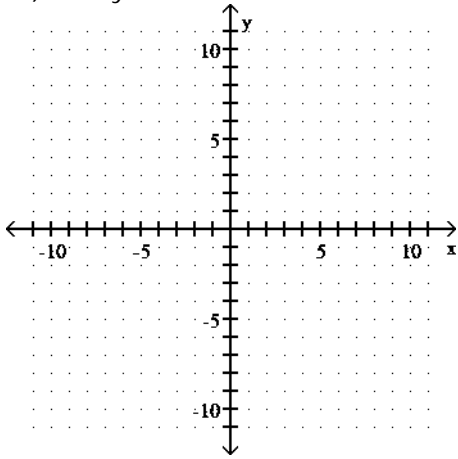

23) _____

A) Slope: $\frac{3}{2}$

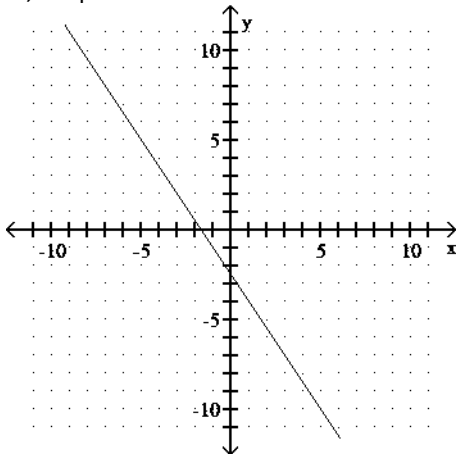

B) Slope: $-\frac{3}{2}$

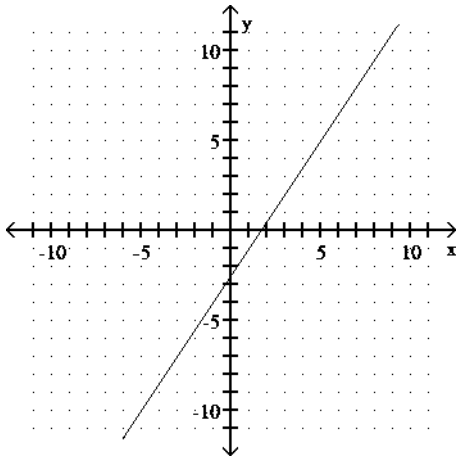

C) Slope: $-\frac{2}{3}$

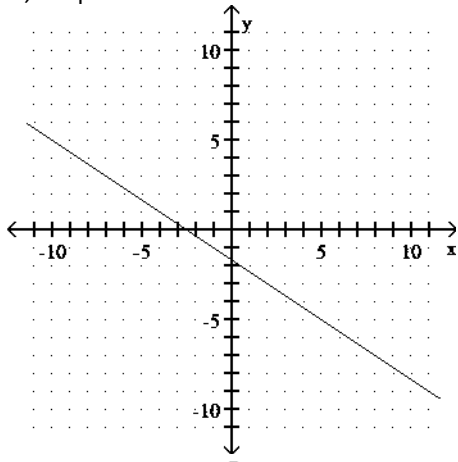

D) Slope: $\frac{2}{3}$

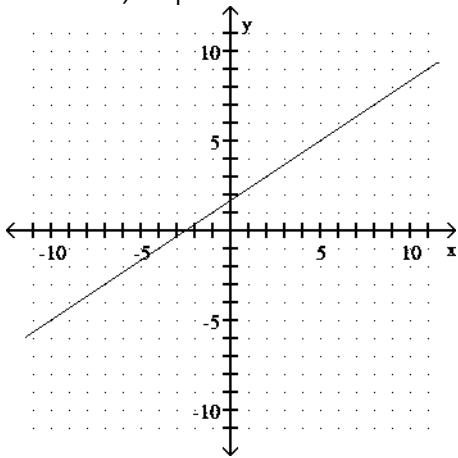

24) $y + 2 = 0$

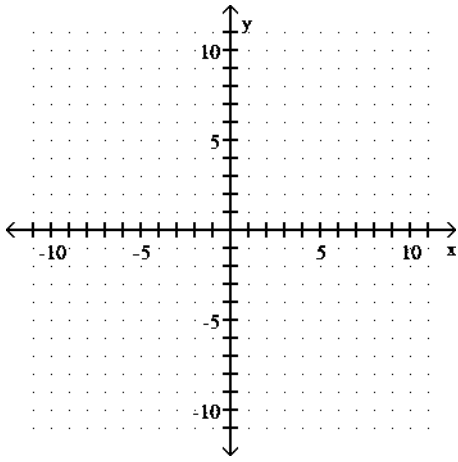

24) _____

A) Slope: $-\frac{1}{2}$

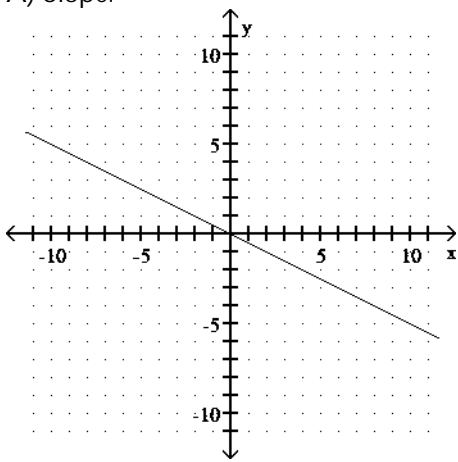

B) Slope: Undefined

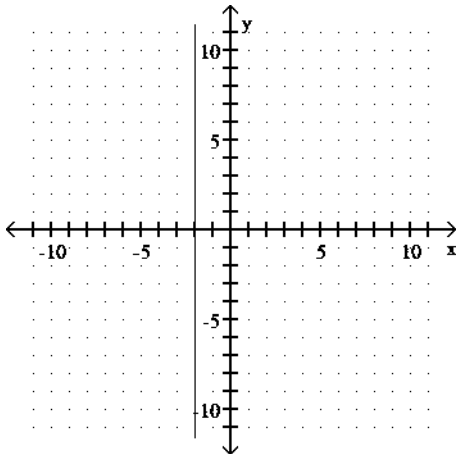

C) Slope: 0

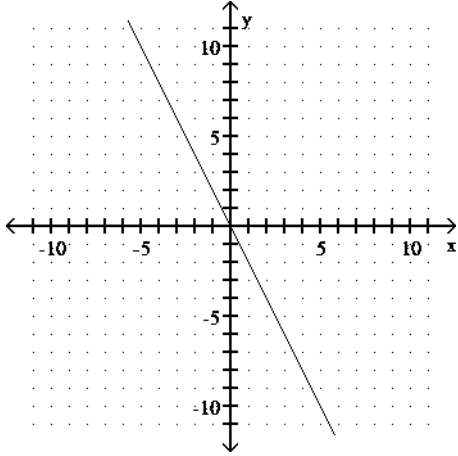
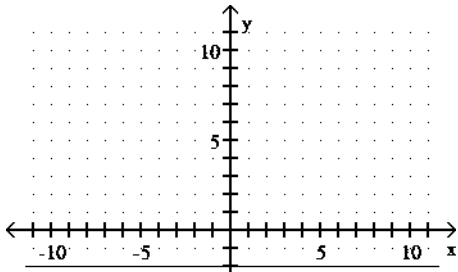

D) Slope: -2

25) $y = -6x$

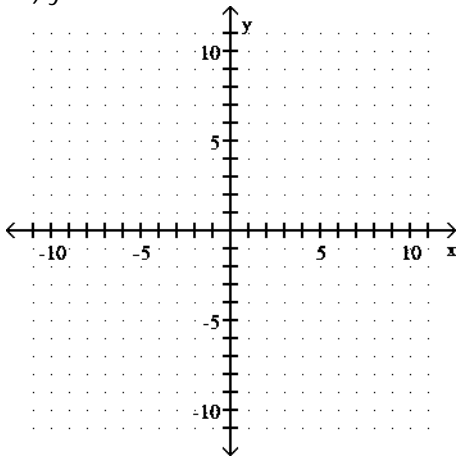

25) _____

A) Slope: 0

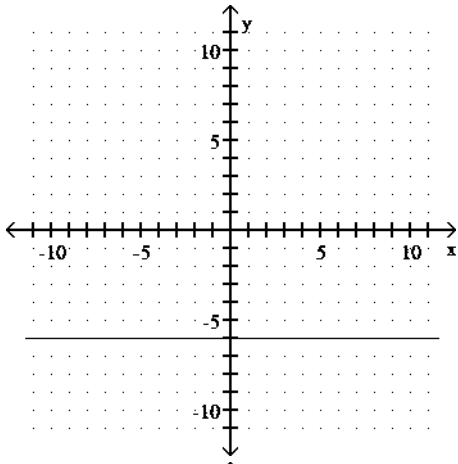

B) Slope: 6

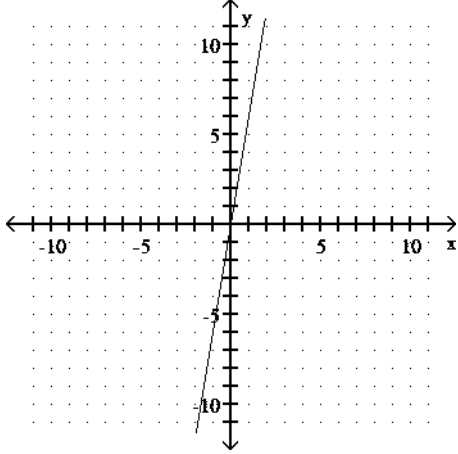

C) Slope: -6

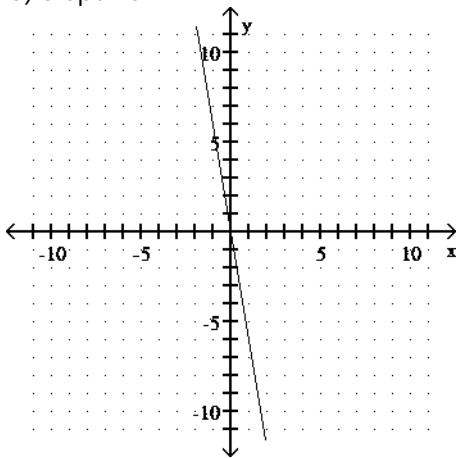

D) Slope: $-\frac{1}{6}$

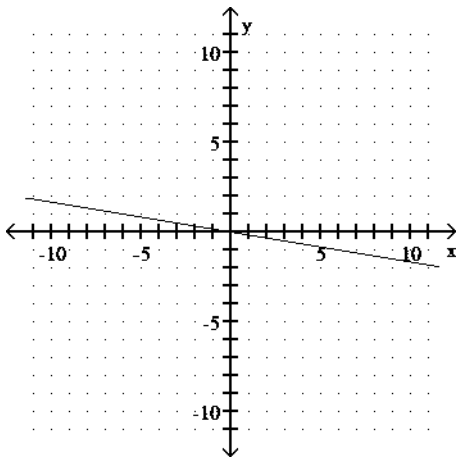

26) $3x - 4y = -25$

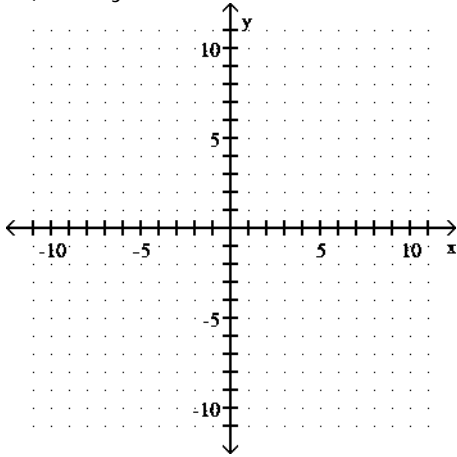

26) _____

A) Slope: $-\frac{3}{4}$

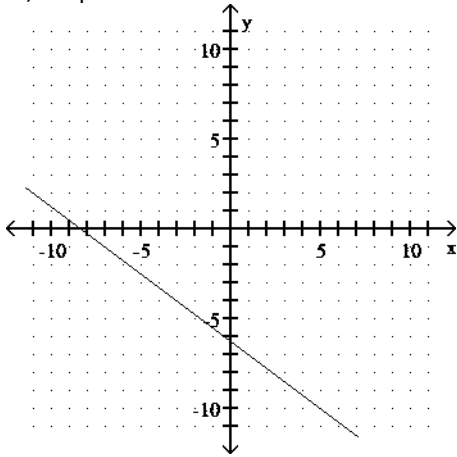

B) Slope: $-\frac{3}{4}$

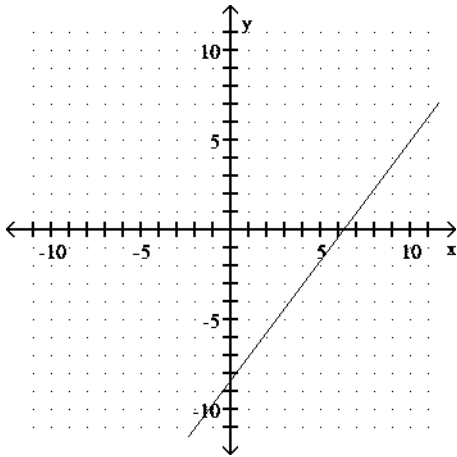

C) Slope: $\frac{4}{3}$

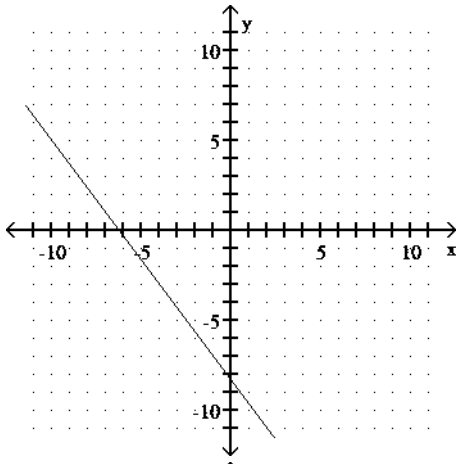

D) Slope: $\frac{3}{4}$

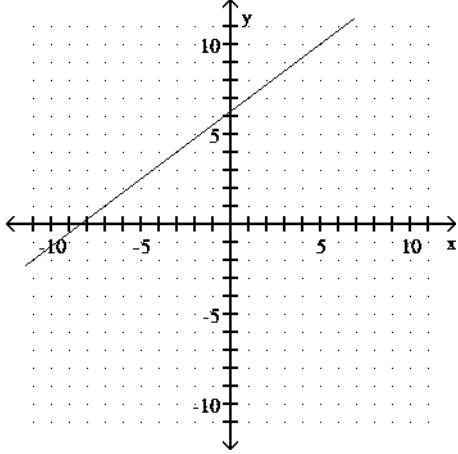

27) $-4y = -3x - 10$

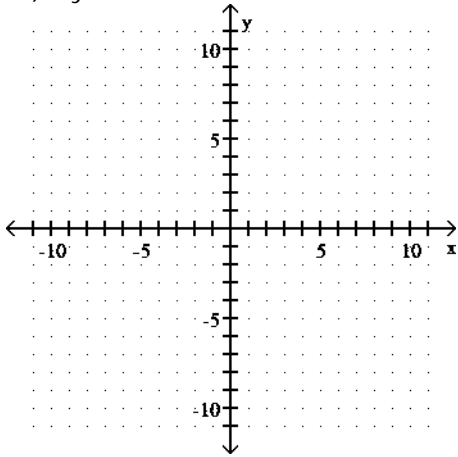

27) _____

A) Slope: $\frac{4}{3}$

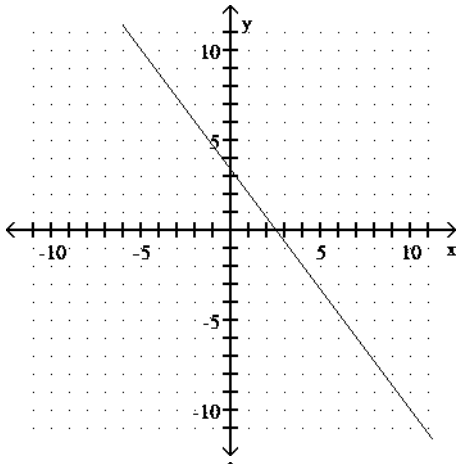

B) Slope: $-\frac{3}{4}$

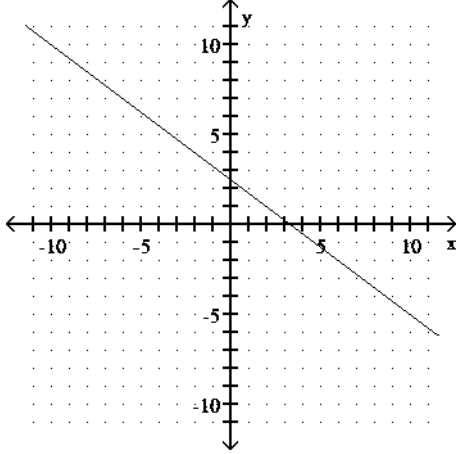

C) Slope: $-\frac{4}{3}$

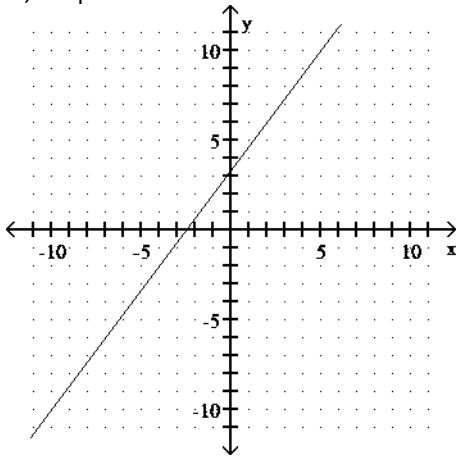

D) Slope: $\frac{3}{4}$

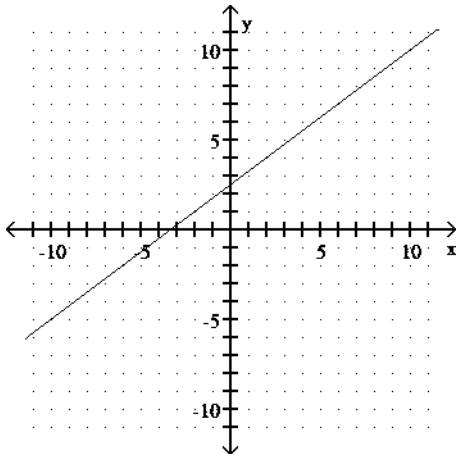

28) $-5y = -3x - 1$

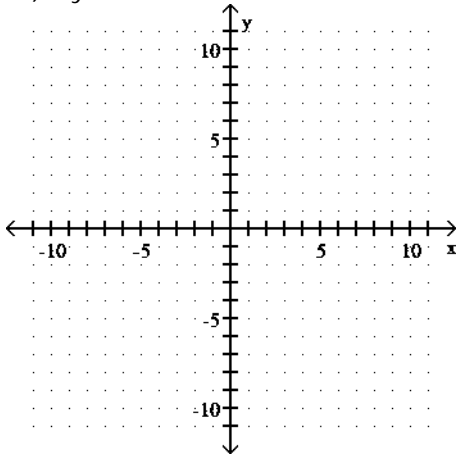

28) _____

A) Slope: $\frac{5}{3}$

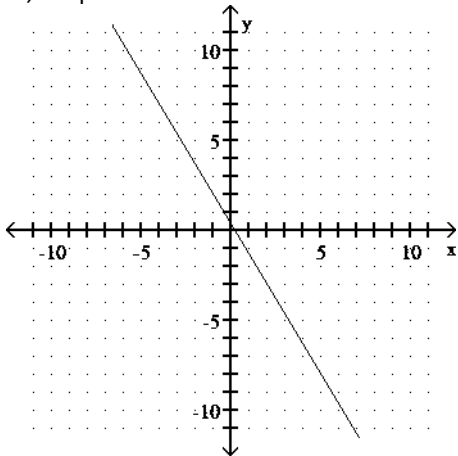

B) Slope: $-\frac{5}{3}$

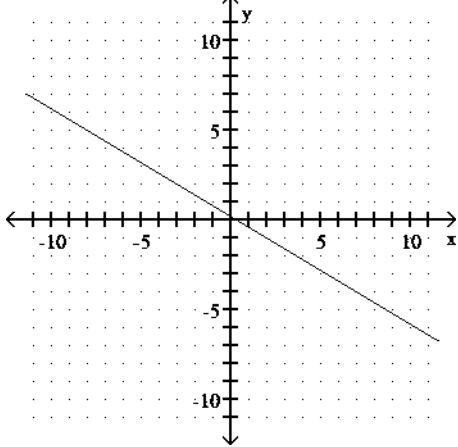

C) Slope: $-\frac{5}{3}$

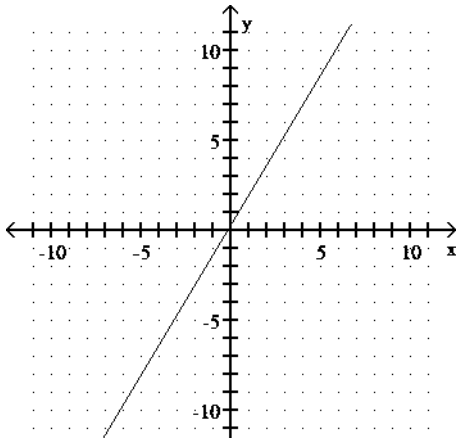

D) Slope: $\frac{3}{5}$

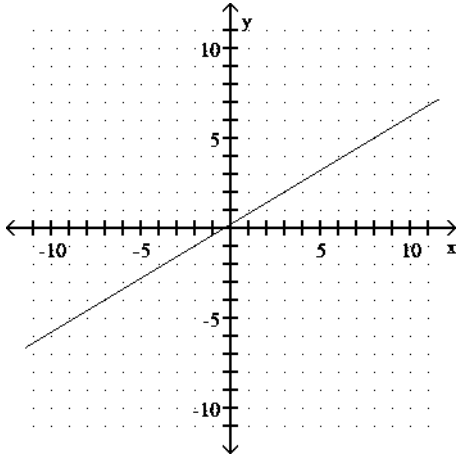

Graph the line described.

29) Through $(0, 2)$; $m = \frac{1}{4}$

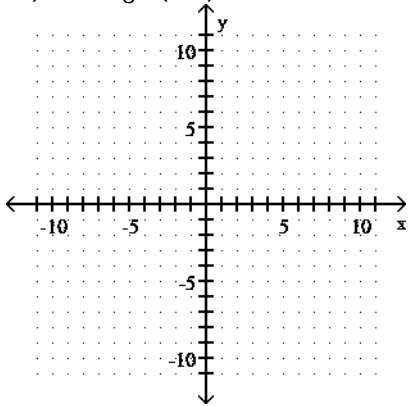

29) _____

A)

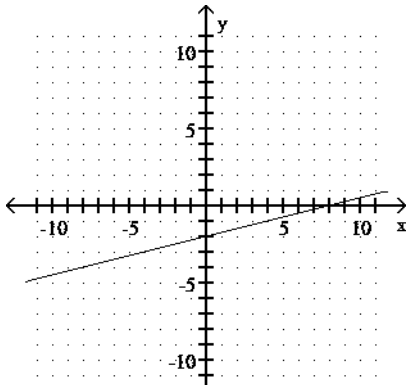

B)

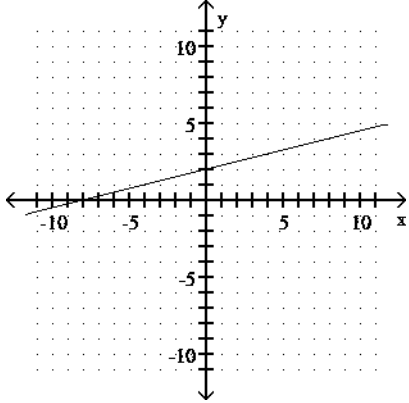

C)

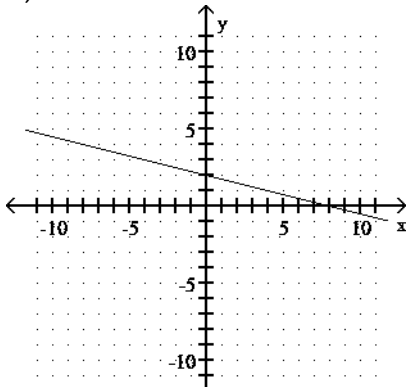

D)

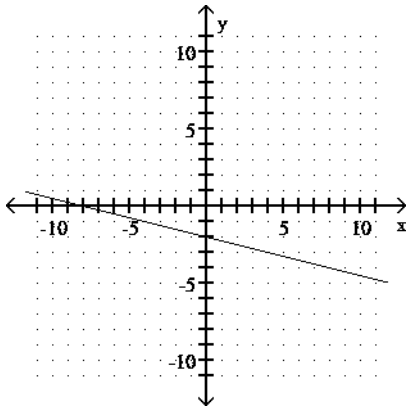

30) Through $(-4, -9)$; $m = 3$

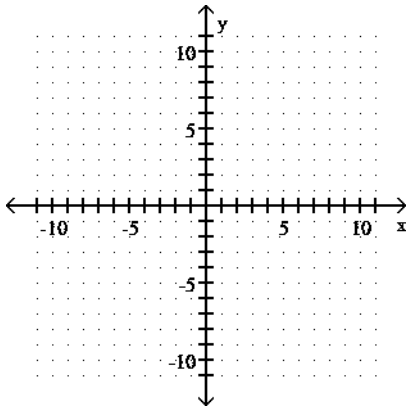

30) _____

A)

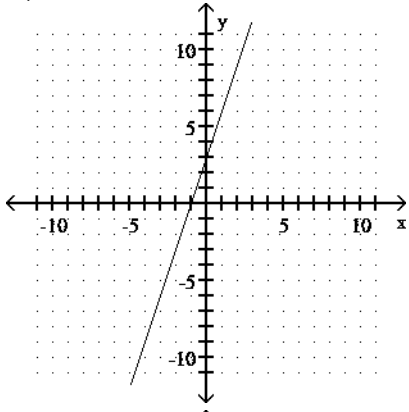

B)

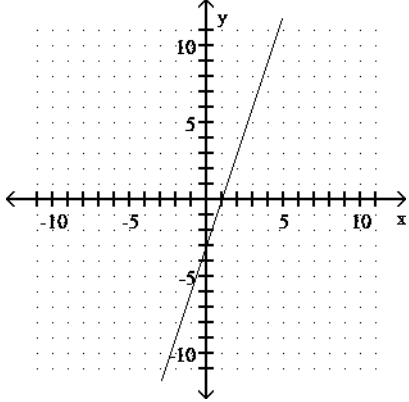

C)

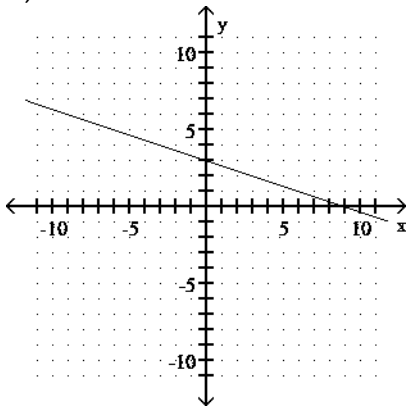

D)

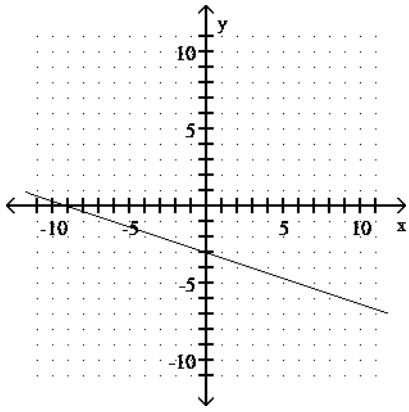

31) Through $(0, 3)$; $m = -6$

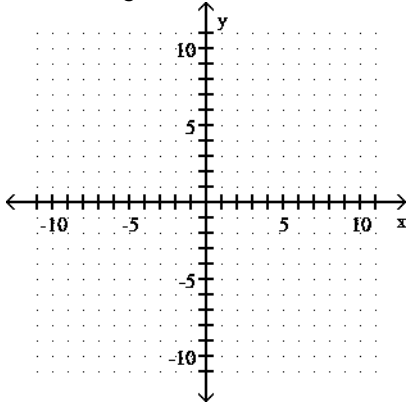

31) _____

A)

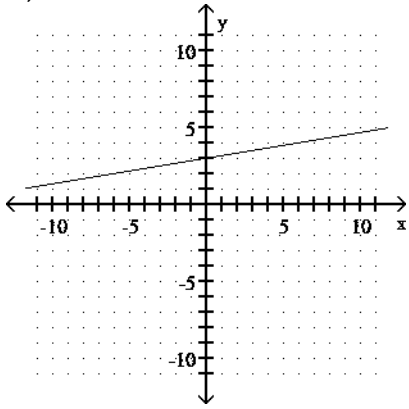

B)

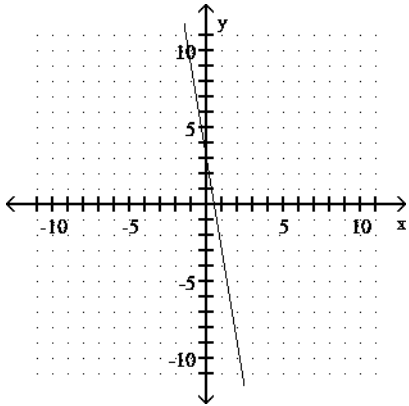

C)

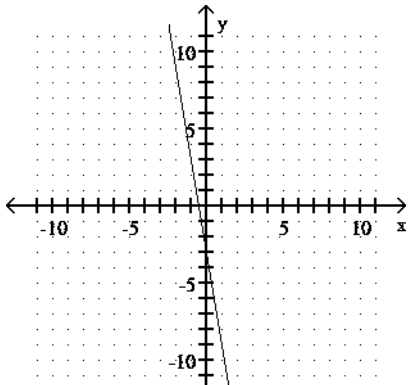

D)

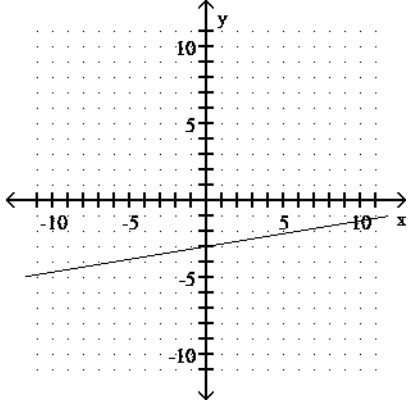

32) Through $(0, 3)$; $m = -\frac{1}{3}$

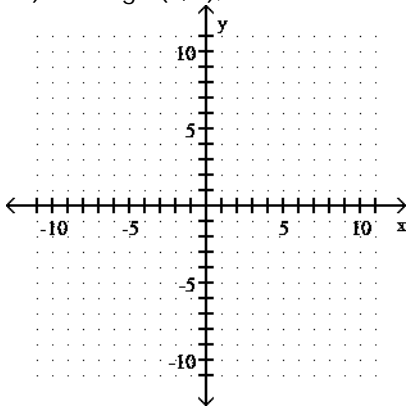

32) _____

A)

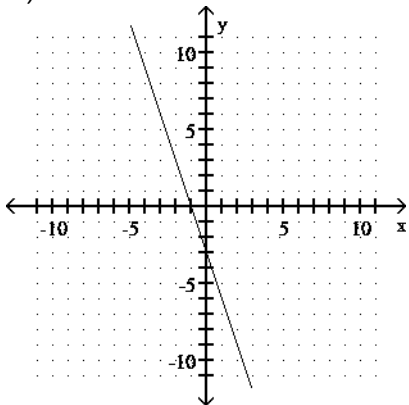

B)

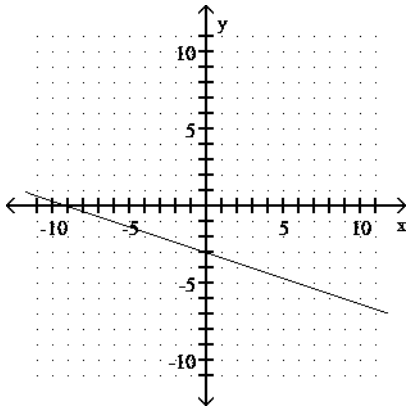

C)

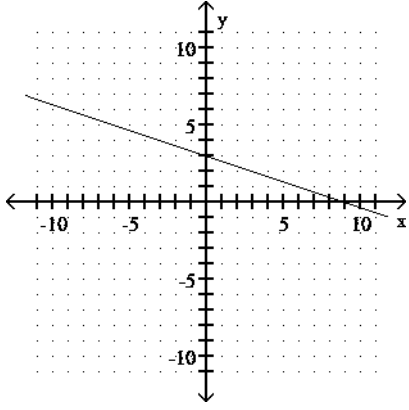
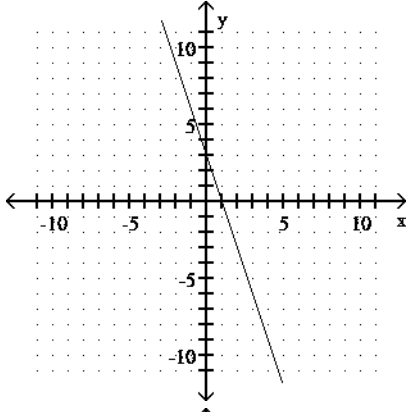

D)

33) Through $(6, 0)$; $m = -\frac{1}{3}$

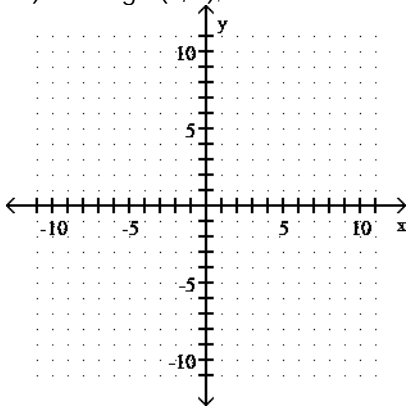

33) _____

A)

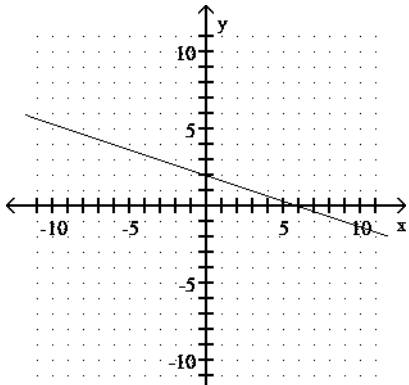

B)

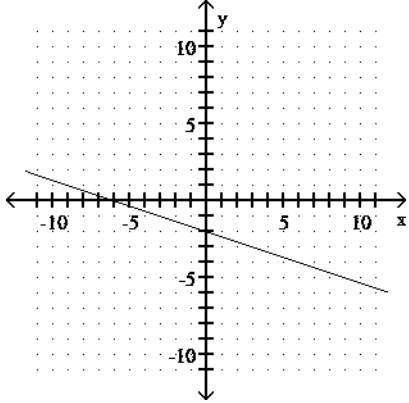

C)

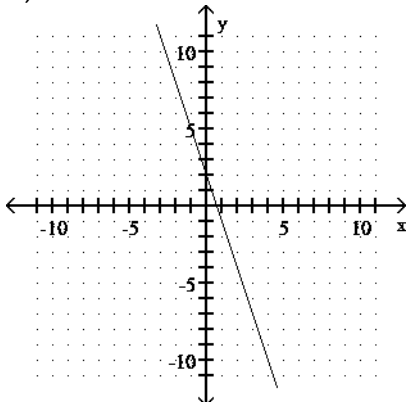

D)

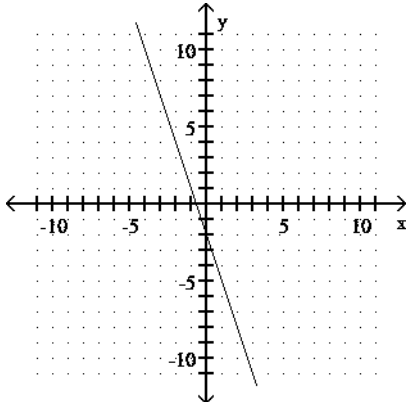

34) Through (6, -4); $m = 0$

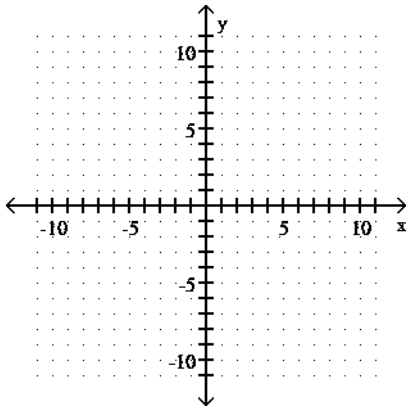

34) _____

A)

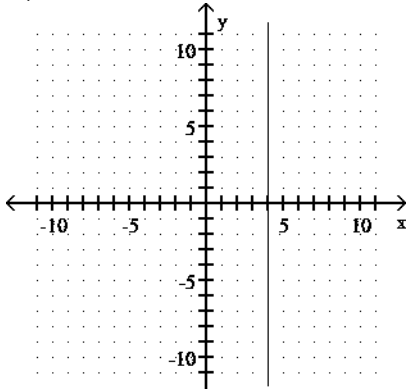

B)

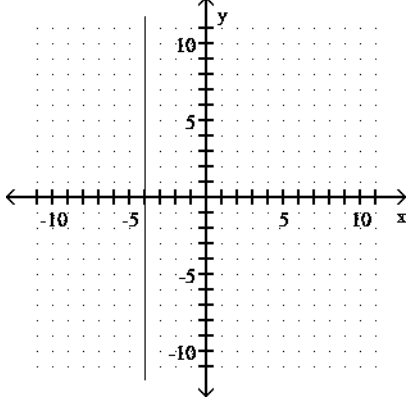

C)

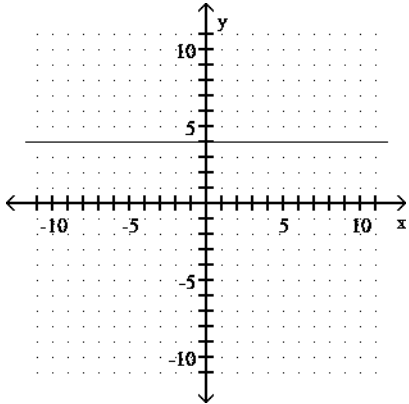

D)

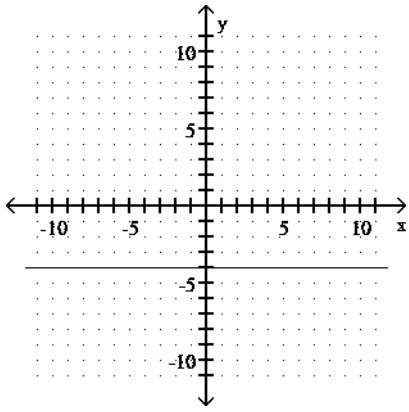

35) $m = 0$; through $(5, -1)$

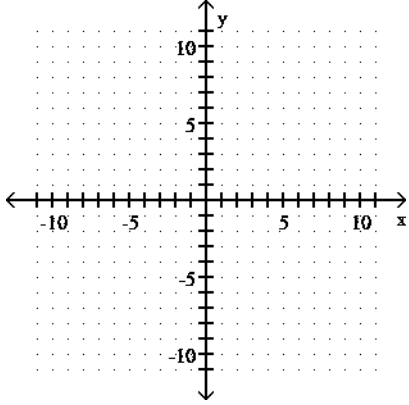

35) _____

A)

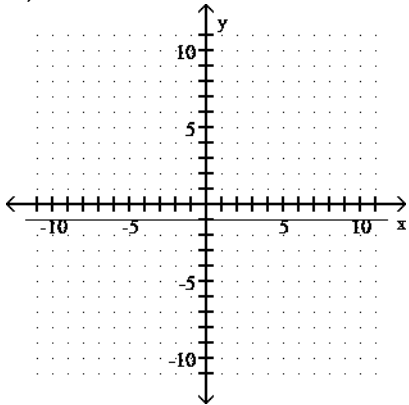

B)

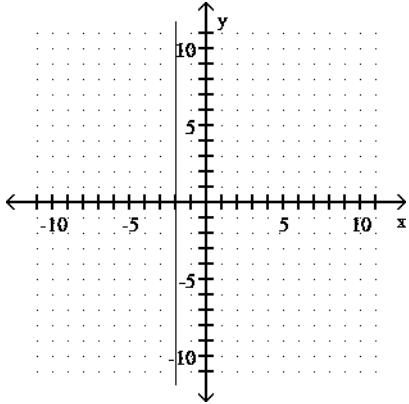

C)

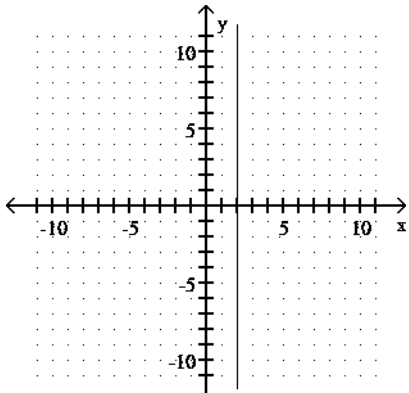

D)

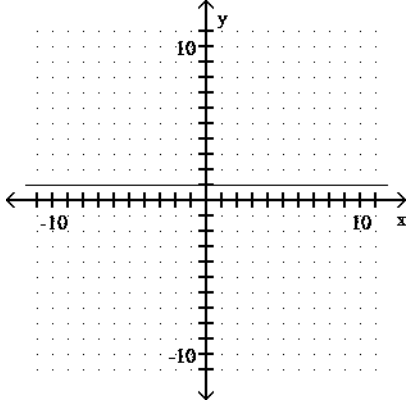

36) Undefined slope; through $(-3, 9)$

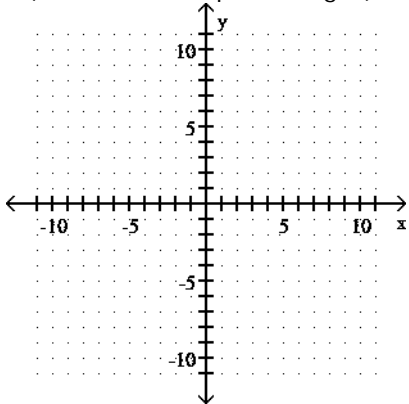

36) _____

A)

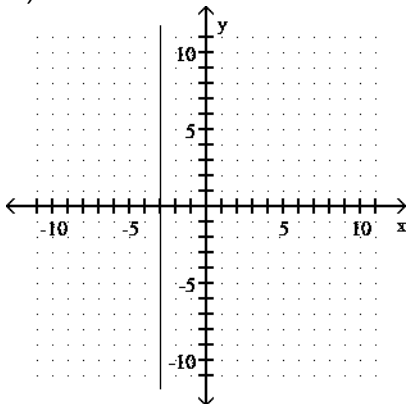

B)

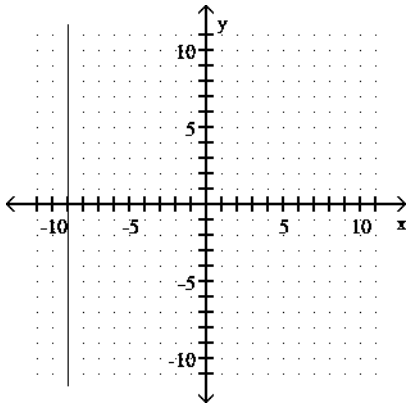

C)

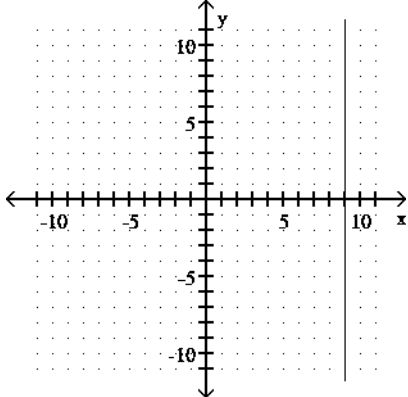

D)

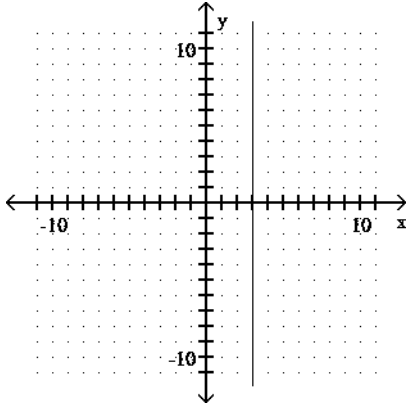

Decide whether the pair of lines is parallel, perpendicular, or neither.

37) $3x - 6y = -13$ and $18x + 9y = 5$ 37) _____

- A) Parallel B) Perpendicular C) Neither

38) $3x - 8y = 5$ and $32x + 12y = -19$ 38) _____

- A) Parallel B) Perpendicular C) Neither

39) $12x + 4y = 16$ and $27x + 9y = 37$ 39) _____

- A) Parallel B) Perpendicular C) Neither

40) The line through $(3, -5)$ and $(-1, 7)$ and the line through $(6, -13)$ and $(-2, 11)$ 40) _____

- A) Parallel B) Perpendicular C) Neither

41) The line through $(-20, 5)$ and $(-4, 7)$ and the line through $(-5, 5)$ and $(7, 4)$ 41) _____

- A) Parallel B) Perpendicular C) Neither

42) $y + 12 = -4x$ and $4y = 24x - 1$ 42) _____

- A) Parallel B) Perpendicular C) Neither

43) $y = 6$ and $6 - y = -3$ 43) _____

- A) Parallel B) Perpendicular C) Neither

Solve the problem.

44) If the slope of the road shown is $\frac{2}{3}$, find the value for h if $v = 2$ ft.

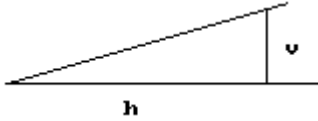

44) _____

- A) 4 ft B) 6 ft C) 3 ft D) 2 ft

45) For the incline shown below, how many feet in the vertical direction correspond to 6 ft in the horizontal direction?

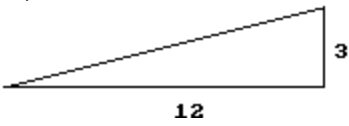

45) _____

- A) 3 ft B) $\frac{3}{2}$ ft C) 24 ft D) 4 ft

46) A motorcycle daredevil is planning a stunt to perform at a county fair. A ramp must be built to give him a 20% grade, or slope. If the vertical height at the end of the ramp must be 12 ft to assure that the stunt is a success, what must be the length of the horizontal run?

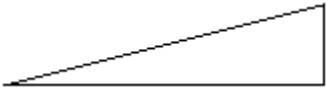

46) _____

- A) 12 ft B) 60 ft C) 2.16 ft D) 216 ft

Find the average rate of change illustrated in the graph.

47)

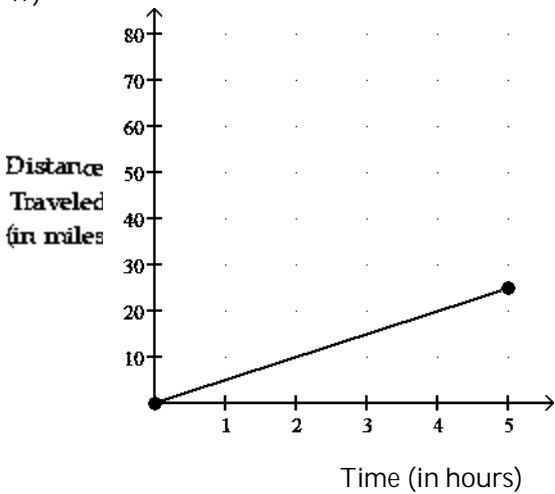

47) _____

- A) .2 miles per hour B) 25 miles per hour
 C) 5 miles per hour D) 2.5 miles per hour

48)

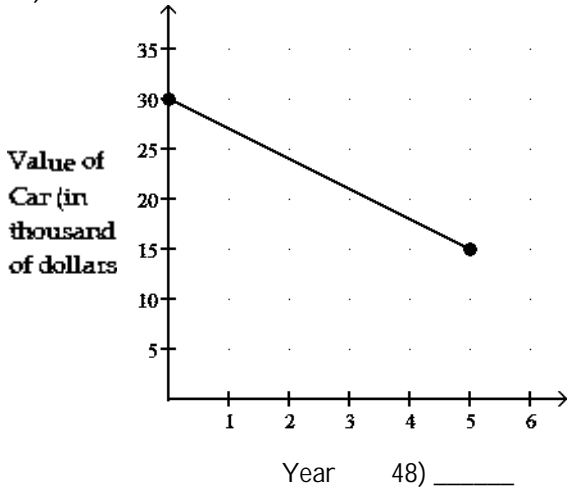

- A) \$4,000.00 per year B) \$3,000.00 per year
C) -\$4,000.00 per year D) -\$3,000.00 per year

49)

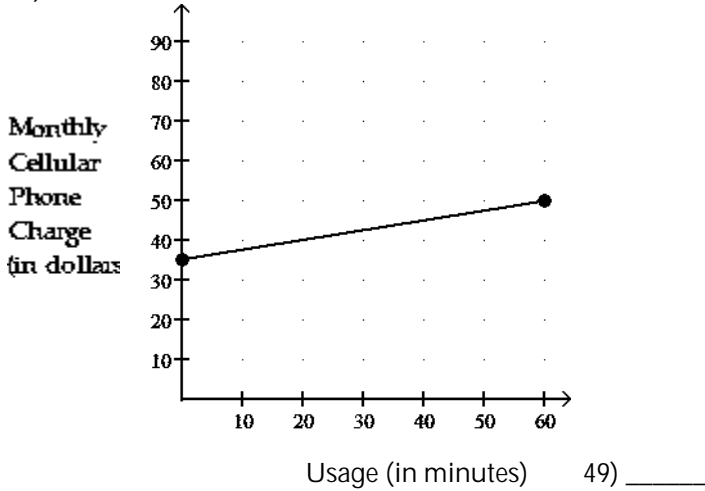

- A) \$4.00 per minute B) \$2.00 per minute
C) \$.50 per minute D) \$.25 per minute

50)

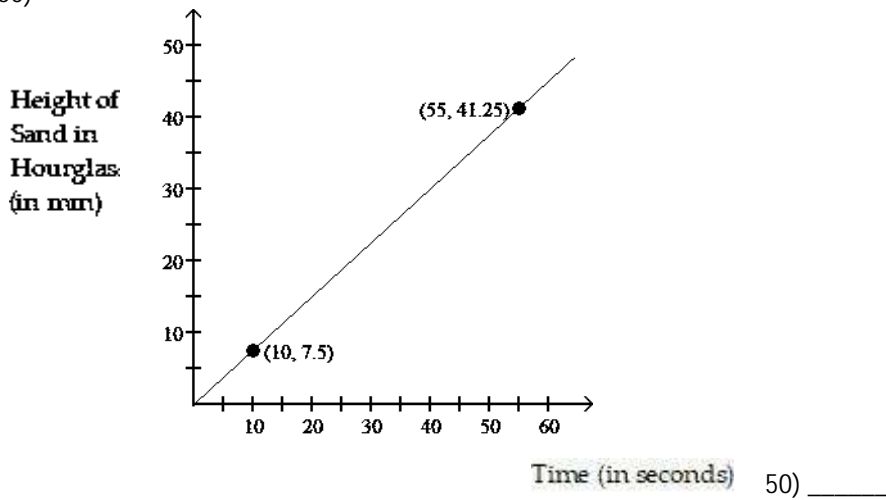

- A) 1 mm per second B) .85 mm per second
 C) .75 mm per second D) 1.3 mm per second

Solve the problem. Round your answer, as needed.

51) The rate of return of certain investments increases as the risk factor of the investment increases. An investment with a risk factor of 2 has a rate of return of 5.0%. An investment with a risk factor of 18 has a rate of return of 16.0%. What is the average rate of return per unit of risk? 51) _____

- A) 1.45% per unit risk B) 1.08% per unit risk
 C) 0.69% per unit risk D) 0.93% per unit risk

52) A deep sea diving bell is being lowered at a constant rate. After 12 minutes, the bell is at a depth of 500 ft. After 45 minutes the bell is at a depth of 1,300 ft. What is the average rate of lowering per minute? 52) _____

- A) 24.2 ft per minute B) 28.9 ft per minute
 C) 0.04 ft per minute D) 17.8 ft per minute

53) The table below shows the weight for a calf raised by a local rancher. Use the information to determine the average rate of change in the calf's weight per day.

Calf's Weight

Day	Weight (in lbs)
1	505
5	525
15	575
25	625
40	700

53) _____

- A) 50 lbs per day B) 5 lbs per day C) 500 lbs per day D) $\frac{1}{5}$ lb per day

Tell whether the points are the vertices of a parallelogram (that is not a rectangle), a rectangle, or neither.

54) (-12, -10), (-10, 0), (3, 7), (1, -3) 54) _____
 A) Rectangle B) Parallelogram C) Neither

55) (-10, -4), (-1, -18), (13, -9), (4, 5) 55) _____
 A) Parallelogram B) Rectangle C) Neither

56) (-10, -6), (-8, 4), (7, 9), (4, 1) 56) _____
 A) Parallelogram B) Neither C) Rectangle

57) (-7, -1), (2, -10), (16, -3), (7, 8) 57) _____
 A) Neither B) Parallelogram C) Rectangle

Provide an appropriate response.

58) Identify whether the slope is positive, negative, zero, or undefined.

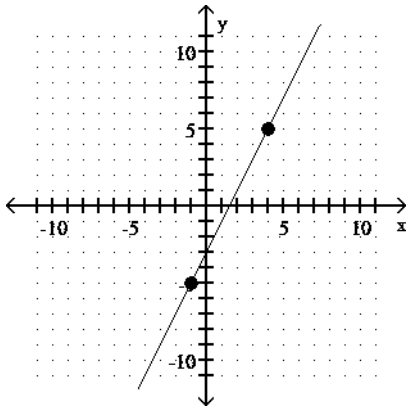

58) _____

- A) Positive B) Undefined C) Negative D) Zero

59) Identify whether the slope is positive, negative, zero, or undefined.

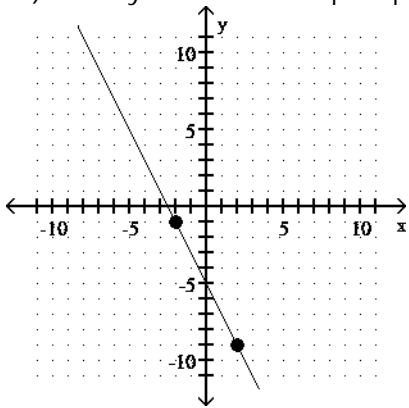

59) _____

- A) Positive B) Zero C) Negative D) Undefined

60) Identify whether the slope is positive, negative, zero, or undefined.

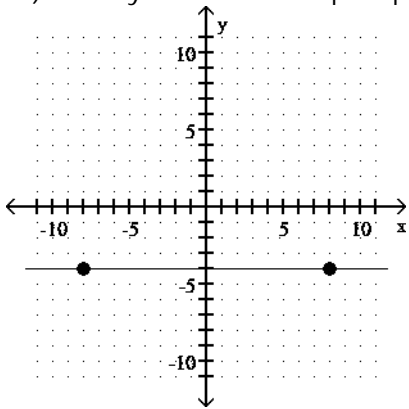

60) _____

- A) Zero B) Undefined C) Positive D) Negative

61) Identify whether the slope is positive, negative, zero, or undefined.

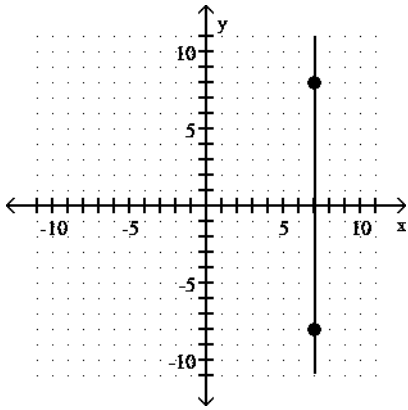

61) _____

- A) Undefined B) Negative C) Zero D) Positive

SHORT ANSWER. Write the word or phrase that best completes each statement or answers the question.

62) Give a definition or an example of the word or phrase: Parallel lines 62) _____

63) Why is the slope of a horizontal line equal to zero? Give an example. 63) _____

64) Explain what is wrong with the statement "The line has no slope." 64) _____

65) Why is the slope of a vertical line undefined? 65) _____

66) Explain why the order in which coordinates are subtracted to find slope does not matter as long as x-coordinates are subtracted in the same order as y-coordinates. 66) _____

67) If one line has a slope of -3 and another line has a slope of -6, which line is steeper? Why? 67) _____

- 1) C
- 2) D
- 3) B
- 4) D
- 5) D
- 6) B
- 7) D
- 8) D
- 9) B
- 10) B
- 11) D
- 12) C
- 13) C
- 14) C
- 15) B
- 16) B
- 17) C
- 18) B
- 19) C
- 20) B
- 21) A
- 22) B
- 23) D
- 24) C
- 25) C
- 26) D
- 27) D
- 28) D
- 29) B
- 30) A
- 31) B
- 32) D
- 33) A
- 34) D
- 35) A
- 36) A
- 37) B
- 38) B
- 39) A
- 40) A
- 41) C
- 42) C
- 43) A
- 44) C
- 45) B
- 46) B
- 47) C
- 48) D
- 49) D
- 50) C
- 51) C

- 52) A
 53) B
 54) B
 55) B
 56) B
 57) A
 58) A
 59) C
 60) A
 61) A

62) Two lines which never intersect. (Answers may vary.)

63) Answers may vary. One possibility: The slope of a horizontal line is equal to zero because the y-values do not change as the x-values change. For example, the points (3, 4) and (7, 4) are two points on a horizontal line. The slope of this line is

zero because $m = \frac{4-4}{7-3} = \frac{0}{4} = 0$.

64) Answers may vary. One possibility: It is not specific enough. The slope of a horizontal line is 0, while the slope of a vertical line is undefined.

65) Answers may vary. One possibility: Let (a, b) and (a, c), $b \neq c$, be any two different points on a vertical line. The slope

of the line = $\frac{y_1 - y_2}{x_1 - x_2} = \frac{b - c}{a - a} = \frac{b - c}{0}$. Division by zero is undefined.

66) Answers may vary. One possibility: $m = \frac{y_2 - y_1}{x_2 - x_1} = \frac{-1 \cdot (y_2 - y_1)}{-1 \cdot (x_2 - x_1)} = \frac{y_1 - y_2}{x_1 - x_2}$.

67) The line with a slope of -6 is steeper, because the larger the absolute value of the slope, the steeper the line. (Explanations will vary.)

Exam

Name _____

MULTIPLE CHOICE. Choose the one alternative that best completes the statement or answers the question.
Choose the graph that matches the equation.

1) $y = 3x + 6$ 1) _____

A)

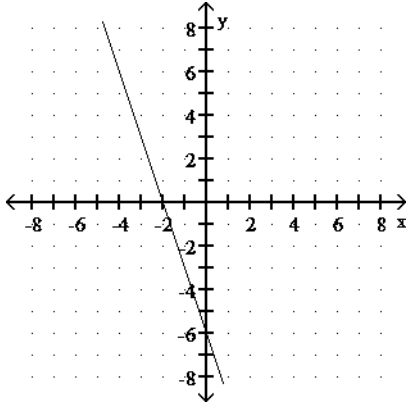

B)

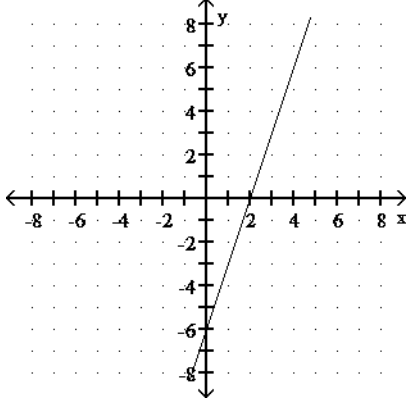

C)

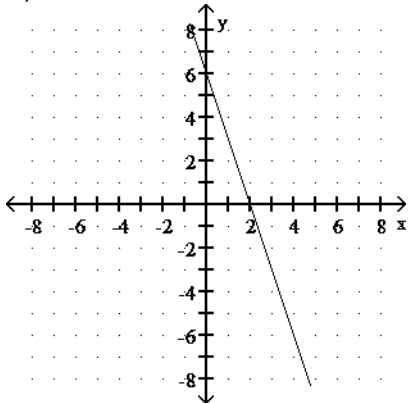

D)

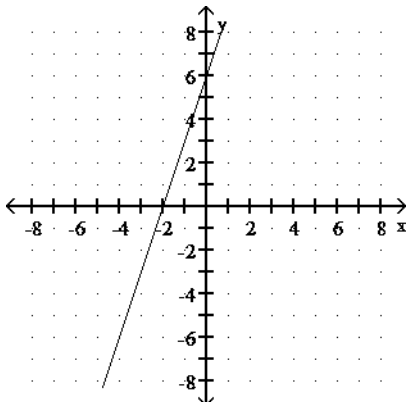

2) $y = 2x - 3$ 2) _____

A)

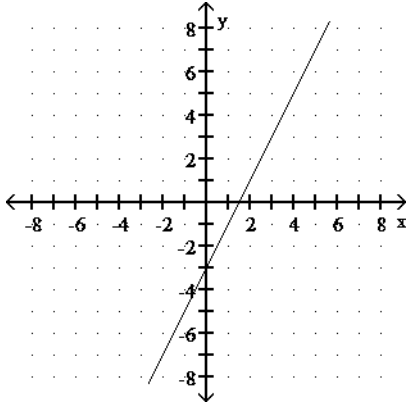

B)

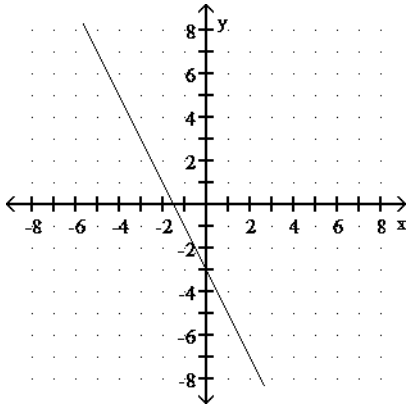

C)

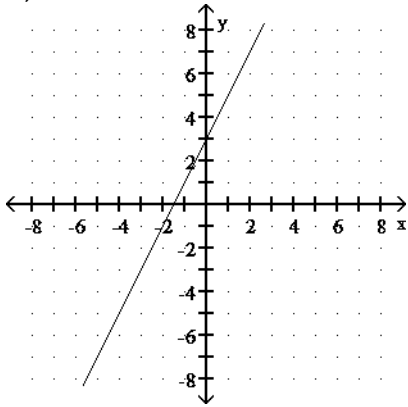

D)

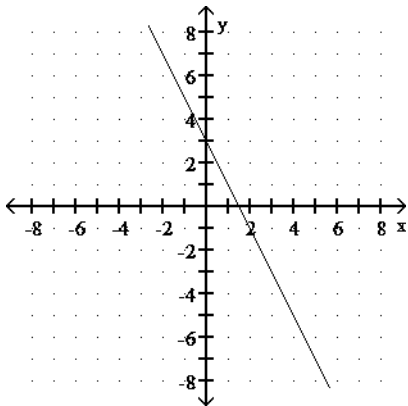

3) $y = -3x + 4$ 3) _____

A)

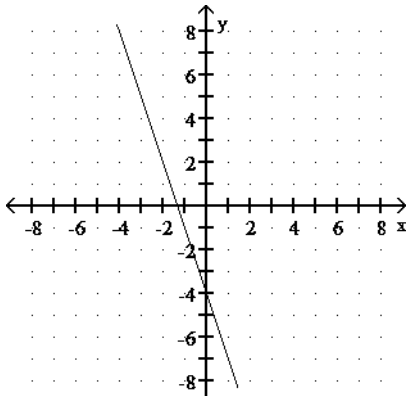

B)

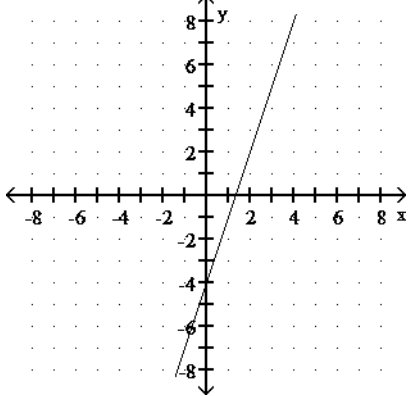

C)

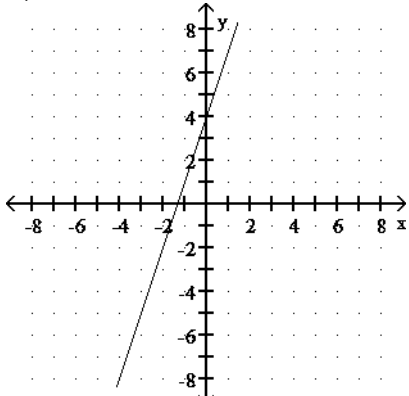

D)

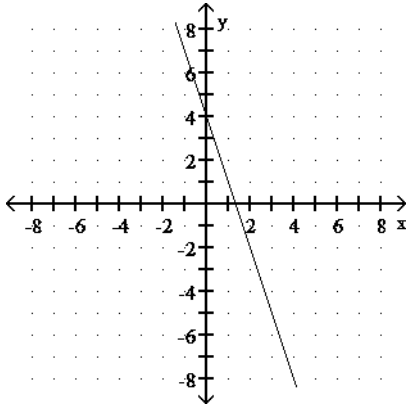

4) $y = -2x - 4$ 4) _____

A)

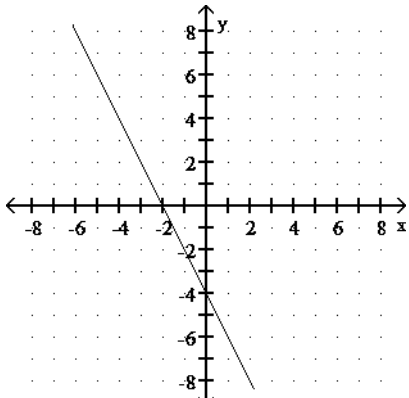

B)

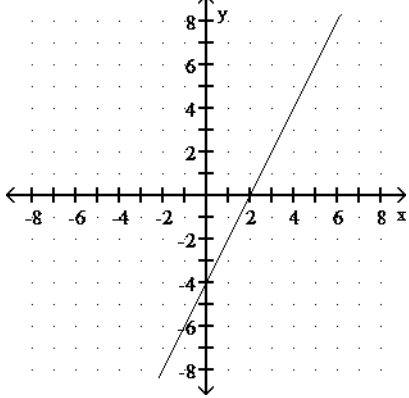

C)

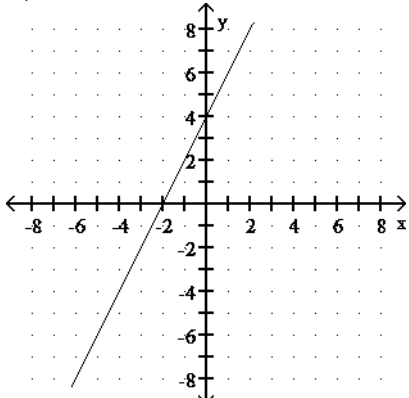

D)

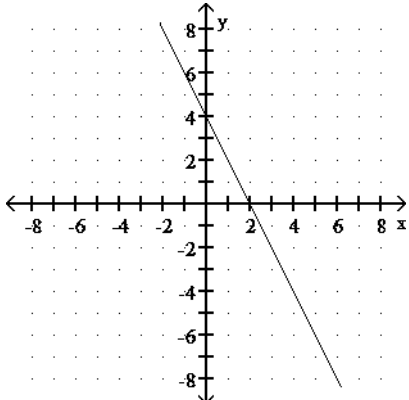

5) $y = -2x$

5) _____

A)

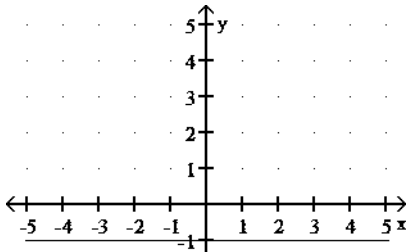

B)

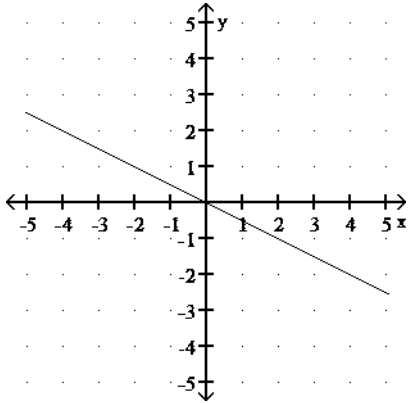

C)

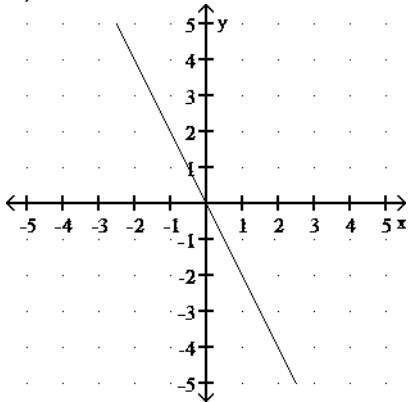

D)

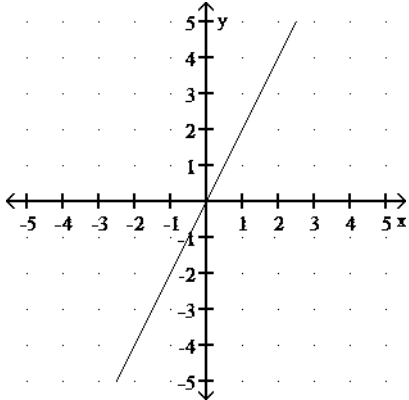

6) $y = 4$ 6) _____

A)

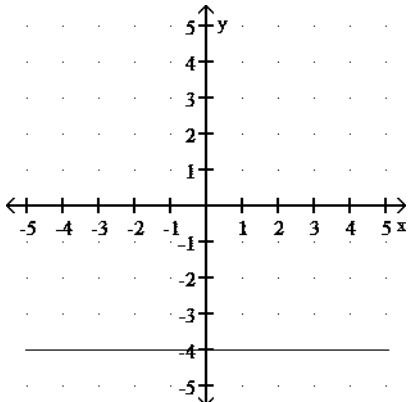

B)

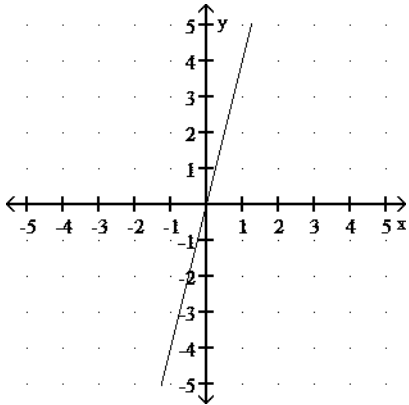

C)

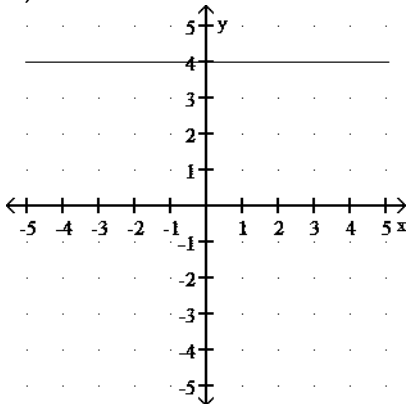

D)

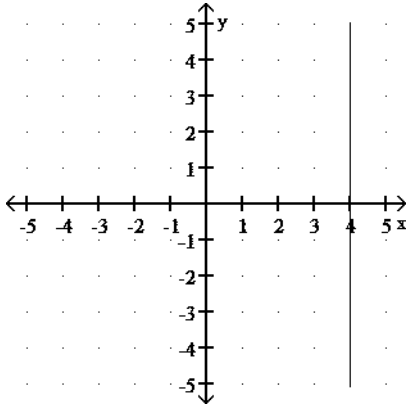

Find the equation in slope-intercept form of the line satisfying the conditions.

7) $m = 9$, passes through $(4, -9)$ 7) _____

- A) $y = 9x - 45$ B) $y = 9x + 44$ C) $y = 10x + 46$ D) $y = 9x - 43$

8) $m = -9$, passes through $(-5, 8)$ 8) _____

- A) $9x + y = 37$ B) $y = -9x - 37$ C) $y = 9x - 35$ D) $y = -9x + 44$

9) $m = -\frac{2}{7}$; y-intercept $(0, \frac{43}{7})$ 9) _____

A) $y = \frac{2}{7}x + \frac{43}{7}$ B) $y = \frac{2}{7}x - \frac{43}{7}$ C) $y = -\frac{2}{7}x + \frac{43}{7}$ D) $y = -\frac{2}{7}x - \frac{43}{7}$

10) $m = -\frac{2}{5}$; y-intercept $(0, 7)$ 10) _____

A) $y = -\frac{2}{5}x + 7$ B) $y = \frac{2}{5}x + 7$ C) $y = \frac{2}{5}x - 7$ D) $y = -\frac{2}{5}x - 7$

11) $m = \frac{2}{3}$; y-intercept $(0, 1)$ 11) _____

A) $y = -\frac{2}{3}x - 1$ B) $y = \frac{2}{3}x - 1$ C) $y = -\frac{2}{3}x + 1$ D) $y = \frac{2}{3}x + 1$

12) $m = \frac{1}{3}$; through $(0, 3)$ 12) _____

A) $y = -\frac{1}{3}x + 3$ B) $y = \frac{1}{3}x + 3$ C) $y = \frac{1}{3}x - 3$ D) $y = -\frac{1}{3}x - 3$

13) $m = \frac{5}{3}$; through $(0, -3)$ 13) _____

A) $y = \frac{5}{3}x + 3$ B) $y = -\frac{5}{3}x - 3$ C) $y = -\frac{5}{3}x + 3$ D) $y = \frac{5}{3}x - 3$

14) Slope 1; y-intercept $(0, -9)$ 14) _____

A) $y = -9x$ B) $x + y = -9$ C) $y = -9x + 1$ D) $y = x - 9$

15) Slope -1; y-intercept $(0, 7)$ 15) _____

A) $-x + y = 7$ B) $y = 7x$ C) $y = 7x - 1$ D) $y = -x + 7$

16) Slope $-\frac{8}{9}$; $b = \frac{14}{3}$ 16) _____

A) $y = \frac{8}{9}x + \frac{14}{3}$ B) $y = -\frac{8}{9}x - \frac{14}{3}$ C) $y = \frac{8}{9}x - \frac{14}{3}$ D) $y = -\frac{8}{9}x + \frac{14}{3}$

17) Slope $-\frac{5}{7}$; $b = 4$ 17) _____

A) $y = \frac{5}{7}x - 4$ B) $y = -\frac{5}{7}x - 4$ C) $y = \frac{5}{7}x + 4$ D) $y = -\frac{5}{7}x + 4$

18) Slope $-\frac{3}{4}$; $b = 4$ 18) _____

A) $y = -\frac{3}{4}x + 4$ B) $y = -\frac{3}{4}x - 4$ C) $y = \frac{3}{4}x - 4$ D) $y = \frac{3}{4}x + 4$

Write the equation in slope-intercept form.

19) $17x + 2y = 1819$ 19) _____

A) $y = 17x - 18$ B) $y = \frac{17}{2}x + 9$ C) $y = -\frac{17}{2}x + 9$ D) $y = \frac{17}{2}x - 9$

20) $4x - 6y = 3$ 20) _____

A) $y = \frac{2}{3}x + \frac{1}{2}$ B) $y = \frac{3}{2}x + \frac{3}{4}$ C) $y = \frac{2}{3}x - \frac{1}{2}$ D) $y = 4x - 3$

21) $x - 3y = 4$ 21) _____

A) $y = \frac{1}{3}x - \frac{4}{3}$ B) $y = 3x - 4$ C) $y = x - \frac{4}{3}$ D) $y = \frac{1}{3}x - 4$

22) $3x - 10y = -6$ 22) _____

A) $y = \frac{3}{10}x + \frac{3}{5}$ B) $y = -\frac{3}{10}x + \frac{3}{5}$ C) $y = 3x + 11$ D) $y = \frac{10}{3}x - 2$

23) $-x + 7y = 3$ 23) _____

A) $y = \frac{1}{7}x - 3$ B) $y = -\frac{1}{7}x + \frac{3}{7}$ C) $y = \frac{1}{7}x + \frac{3}{7}$ D) $y = x - \frac{3}{7}$

24) $-7x + 2y = 3$ 24) _____

A) $y = 7x - 3$ B) $y = \frac{7}{2}x - \frac{3}{2}$ C) $y = \frac{7}{2}x + \frac{3}{2}$ D) $y = \frac{2}{7}x + \frac{3}{7}$

Find the slope and the y-intercept of the line.

25) $7x + 8y = 75$ 25) _____

A) Slope $\frac{7}{8}$; y-intercept $(0, \frac{75}{8})$ B) Slope $-\frac{1}{7}$; y-intercept $(0, \frac{8}{75})$

C) Slope $\frac{1}{7}$; y-intercept $(0, \frac{8}{75})$ D) Slope $-\frac{7}{8}$; y-intercept $(0, \frac{75}{8})$

26) $3x + 7y = 34$ 26) _____

A) Slope $\frac{3}{7}$; y-intercept $(0, \frac{34}{7})$ B) Slope $-\frac{7}{3}$; y-intercept $(0, \frac{7}{34})$

C) Slope $-\frac{3}{7}$; y-intercept $(0, \frac{34}{7})$ D) Slope $\frac{7}{3}$; y-intercept $(0, \frac{34}{7})$

27) $4x - 5y = 5$ 27) _____

A) Slope $-\frac{4}{5}$; y-intercept $(0, 1)$ B) Slope 1 ; y-intercept $(0, 1)$

C) Slope -1; y-intercept (0, -1) D) Slope $\frac{4}{5}$; y-intercept (0, -1)

28) $4x - 5y = -5$ 28) _____

A) Slope $-\frac{5}{4}$; y-intercept (0, 1) B) Slope $\frac{5}{4}$; y-intercept (0, -1)

C) Slope $\frac{4}{5}$; y-intercept (0, 1) D) Slope $-\frac{4}{5}$; y-intercept (0, -1)

29) $-x + 6y = 7$ 29) _____

A) Slope $-\frac{1}{6}$; y-intercept $(0, \frac{7}{6})$ B) Slope -1; y-intercept $(0, \frac{7}{6})$

C) Slope $\frac{1}{6}$; y-intercept (0, 7) D) Slope $\frac{1}{6}$; y-intercept $(0, \frac{7}{6})$

30) $-3x + 5y = 2$ 30) _____

A) Slope $\frac{3}{5}$; y-intercept $(0, -\frac{2}{5})$ B) Slope 3; y-intercept (0, -2)

C) Slope $\frac{3}{5}$; y-intercept $(0, \frac{2}{5})$ D) Slope $\frac{5}{3}$; y-intercept $(0, \frac{2}{3})$

Find an equation of the line that satisfies the conditions. Write the equation in standard form.

31) Through (2, 3); $m = -\frac{2}{3}$ 31) _____

A) $3x + 2y = -13$ B) $2x + 3y = -13$ C) $2x + 3y = 13$ D) $2x - 3y = 13$

32) Through (0, 2); $m = -\frac{5}{9}$ 32) _____

A) $5x - 9y = 18$ B) $5x + 9y = -18$ C) $5x + 9y = 18$ D) $9x + 5y = -18$

33) Through (0, 7); $m = \frac{2}{5}$ 33) _____

A) $2x - 5y = 35$ B) $5x - 2y = -35$ C) $2x + 5y = -35$ D) $2x - 5y = -35$

34) Through (0, 5); $m = \frac{2}{7}$ 34) _____

A) $2x - 7y = 35$ B) $7x - 2y = -35$ C) $2x - 7y = -35$ D) $2x + 7y = -35$

35) Through (4, 5); $m = 0$ 35) _____

A) $y = 5$ B) $x = 4$ C) $x = -5$ D) $y = -4$

36) Through (-6, -10); horizontal 36) _____

A) $x = 10$ B) $x = -6$ C) $y = 6$ D) $y = -10$

37) x-intercept (-7, 0); $m = 8$ 37) _____

A) $8x + y = -7$ B) $7x + y = 8$ C) $-7x + y = 8$ D) $8x - y = -56$

38) x-intercept $(-6, 0)$; $m = -8$ 38) _____

A) $8x + y = -48$ B) $-6x + y = -8$ C) $8x - y = 6$ D) $6x + y = -8$

39) Through $(-5, -9)$; undefined slope 39) _____

A) $y = -5$ B) $y = -9$ C) $x = -5$ D) $x = -9$

40) Through $\left(\frac{1}{7}, \frac{8}{5}\right)$; vertical 40) _____

A) $y = \frac{8}{5}$ B) $y = \frac{1}{7}$ C) $x = \frac{1}{7}$ D) $x = \frac{8}{5}$

Find an equation of the line passing through the two points. Write the equation in standard form.

41) $(7, -6)$ and $(0, -2)$ 41) _____

A) $13x + 2y = -4$ B) $-13x - 2y = -4$ C) $4x + 7y = -14$ D) $-4x + 7y = -14$

42) $(-4, 0)$ and $(-6, 7)$ 42) _____

A) $4x + 13y = -115$ B) $7x + 2y = -28$
 C) $-4x - 13y = -115$ D) $-7x + 2y = -28$

43) $(-7, -4)$ and $(1, 7)$ 43) _____

A) $-11x - 8y = -45$ B) $3x + 6y = -39$ C) $11x - 8y = -45$ D) $-3x - 6y = -39$

44) $(-6, 6)$ and $(-4, 9)$ 44) _____

A) $-12x - 13y = -165$ B) $-3x - 2y = -30$
 C) $12x + 13y = -165$ D) $3x - 2y = -30$

45) $(10, 9)$ and $(10, 1)$ 45) _____

A) $x = 10$ B) $x + y = 11$ C) $y = 9$ D) $x + y = 19$

46) $(-2, 6)$ and $(-1, 6)$ 46) _____

A) $-2x - y = 0$ B) $-x - 2y = 0$ C) $x = -2$ D) $y = 6$

47) $\left(\frac{3}{4}, \frac{5}{4}\right)$ and $\left(\frac{1}{3}, \frac{2}{3}\right)$ 47) _____

A) $-5x + 7y = -1$ B) $-5x - 7y = -1$ C) $7x - 5y = -1$ D) $-\frac{7}{5}x + y = \frac{1}{5}$

Find an equation of the line satisfying the conditions. Write the equation in slope-intercept form.

48) Through $(-6, 5)$; parallel to $-7x + 5y = 57$ 48) _____

A) $y = \frac{5}{7}x + \frac{30}{7}$ B) $y = -\frac{7}{5}x - \frac{67}{5}$ C) $y = \frac{7}{5}x + \frac{67}{5}$ D) $y = -\frac{5}{7}x - \frac{30}{7}$

49) Through $(-6, 7)$; parallel to $3x + 7y = 3$ 49) _____

A) $y = \frac{3}{7}x - \frac{31}{7}$ B) $y = -\frac{7}{3}x + \frac{7}{3}$ C) $y = \frac{3}{7}x + \frac{3}{7}$ D) $y = -\frac{3}{7}x + \frac{31}{7}$

50) Through (-3, 8); perpendicular to $-3x + 4y = -23$ 50) _____
 A) $y = \frac{3}{4}x + \frac{41}{4}$ B) $y = -\frac{4}{3}x + 4$ C) $y = \frac{4}{3}x + 12$ D) $y = -\frac{3}{4}x + \frac{23}{4}$

51) Through (-5, -2); perpendicular to $-5x - 2y = 27$ 51) _____
 A) $y = \frac{2}{5}x$ B) $y = -\frac{5}{2}x - \frac{29}{2}$ C) $y = -\frac{2}{5}x - 4$ D) $y = \frac{5}{2}x + \frac{21}{2}$

52) Through (1, 9); perpendicular to $x = 5$ 52) _____
 A) $y = 1$ B) $y = -9$ C) $y = -1$ D) $y = 9$

Solve the problem.

53) It costs \$43 per hour plus a flat fee of \$23 for a plumber to make a house call. What is an equation of the form $y = mx + b$ for this situation? 53) _____

A) $y = 43x$ B) $y = 23x + 43$ C) $y = 23x$ D) $y = 43x + 23$

54) Using a phone card to make a long distance call costs a flat fee of \$0.24 plus \$0.15 per minute starting with the first minute. What is an equation of the form $y = mx + b$ for this situation? 54) _____

A) $y = 0.24x + 0.15$ B) $y = 0.15x + 0.24$ C) $y = 0.24x$ D) $y = 0.15x$

55) The number of births in County A has been increasing in recent years. Using the information given on the bar graph for the years 1960 and 1990, find an equation to model the number of births y for the year x . Let $x = 0$ correspond to the year 1960.

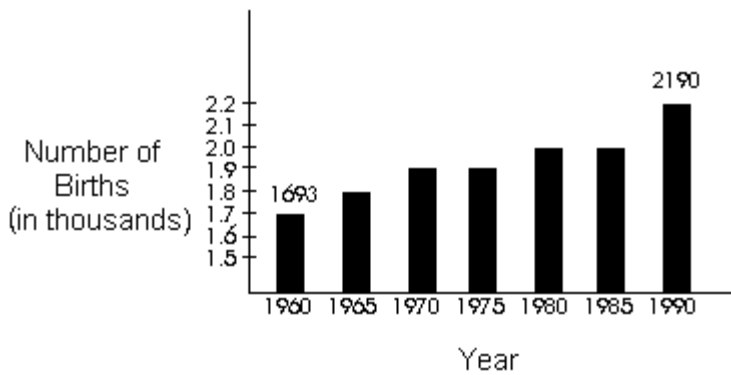

55) _____

A) $y = \frac{30}{497}x + \frac{930140}{497}$ B) $y = \frac{497}{1990}x + 1693$
 C) $y = \frac{497}{30}x + 1693$ D) $y = \frac{1990}{497}x - 2190$

56) Let x represent the number of pounds of apples sold at \$1.91 per pound, and let y represent the total price paid for the apples. Write an equation for this situation. Then give the ordered pair with an x -value of 5 associated with this equation. 56) _____

A) $x = 1.91 + y$; (5, 3.09) B) $y = 1.91 + x$; (5, 6.91)
 C) $y = 1.91x$; (5, 9.55) D) $x = 1.91y$; (5, 2.62)

57) Let x represent the number of gallons of gas sold at \$1.90 per gallon, and let y represent the total cost of the gasoline

(in dollars). Write an equation for this situation. Then give the ordered pair with an x-value of 12 associated with this equation. 57) _____

- A) $x = 1.90 + y$; (12, 10.10) B) $y = 1.90 + x$; (12, 13.90)
C) $x = 1.90y$; (12, 6.32) D) $y = 1.90x$; (12, 22.80)

58) It costs \$17 per hour plus a flat fee of \$29 for a plumber to make a house call. Find the total cost to have a plumber come to a house for 10 hours. 58) _____

- A) \$503 B) \$170 C) \$199 D) \$307

59) Using a phone card to make a long distance call costs a flat fee of \$0.71 plus \$0.29 per minute starting with the first minute. Find the total cost of a phone call which lasts 13 minutes. 59) _____

- A) \$3.77 B) \$9.52 C) \$13.21 D) \$4.48

60) It costs \$36 per hour plus a flat fee of \$22 for a plumber to make a house call. Find the number of hours a plumber worked if the total cost was \$310. 60) _____

- A) 8 B) 6 C) 18 D) 20

61) Suppose the sales of a particular brand of appliance satisfy the relationship $S(x) = 230x + 2,500$, where $S(x)$ represents the number of sales in year x , with $x = 0$ corresponding to 1982. Find the number of sales in 1995. 61) _____

- A) 5,490 B) 10,980 C) 10,750 D) 5,260

62) The mathematical model $C(x) = 100x + 80,000$ represents the cost in dollars a company has in manufacturing x items during a month. Based on this, how much does it cost to produce 800 items? 62) _____

- A) \$800.00 B) \$160,000 C) \$80,000 D) \$1.00

SHORT ANSWER. Write the word or phrase that best completes each statement or answers the question. Provide an appropriate response.

63) Can an equation of a vertical line be written in slope-intercept form? Explain. 63) _____

64) Can the point-slope form of the equation of a line be used to write an equation of a vertical line? Explain. 64) _____

65) Describe a situation in which it would be more convenient to use the point-slope form of the equation of a line than the slope-intercept form. 65) _____

66) The total number of reported cases of AIDS in the United States has risen from 372 in 1981 to 100,000 in 1989 and 200,000 in 1992. Does a linear equation fit this data? Explain. 66) _____

- 1) D
- 2) A
- 3) D
- 4) A
- 5) C
- 6) C
- 7) A
- 8) B
- 9) C
- 10) A
- 11) D
- 12) B
- 13) D
- 14) D
- 15) D
- 16) D
- 17) D
- 18) A
- 19) C
- 20) C
- 21) A
- 22) A
- 23) C
- 24) C
- 25) D
- 26) C
- 27) D
- 28) C
- 29) D
- 30) C
- 31) C
- 32) C
- 33) D
- 34) C
- 35) A
- 36) D
- 37) D
- 38) A
- 39) C
- 40) C
- 41) C
- 42) B
- 43) C
- 44) D
- 45) A
- 46) D
- 47) C
- 48) C
- 49) D
- 50) B
- 51) A

- 52) D
- 53) D
- 54) B
- 55) C
- 56) C
- 57) D
- 58) C
- 59) D
- 60) A
- 61) A
- 62) B

63) No. In the slope-intercept form of the equation of a line, x is multiplied by slope; however, the slope of a vertical line is undefined. (Explanations will vary.)

64) No. In the point-slope form of the equation of a line, $(x - x_1)$ is multiplied by slope, but the slope of a vertical line is undefined. (Explanations will vary.)

65) Answers will vary. One possibility: Slope-intercept form works well if you know the slope of the line and the y -intercept. However, point-slope form is more convenient if you know the slope of the line and a point that is not the y -intercept.

66) No, the data cannot be modeled by a linear equation because the reported cases are not increasing at a constant rate. Assume a linear equation, and examine the slope of the two line segments. The slope of the segment from $(0, 372)$ to $(8, 100,000)$ is 12,453.5 while the slope of the segment from $(8, 100,000)$ to $(11, 200,000)$ is 33,333. $\bar{3}$. (Explanations will vary.)

Exam

Name _____

MULTIPLE CHOICE. Choose the one alternative that best completes the statement or answers the question.
The boundary of the graph of the linear inequality will be a _____ line, and the shading will be _____ the line. Fill in the first blank with either solid or dashed. Fill in the second blank with above or below.

1) $y < x + \frac{2}{3}$ 1) _____

- A) solid; above B) solid; below C) dashed; above D) dashed; below

2) $y > -3x + \frac{5}{6}$ 2) _____

- A) solid; above B) solid; below C) dashed; below D) dashed; above

3) $y \geq -\frac{2}{3}x + \frac{3}{4}$ 3) _____

- A) solid; above B) solid; below C) dashed; below D) dashed; above

4) $y \leq 3x - \frac{3}{7}$ 4) _____

- A) dashed; above B) solid; above C) dashed; below D) solid; below

Graph the linear inequality in two variables.

5) $5x + y \leq 6$

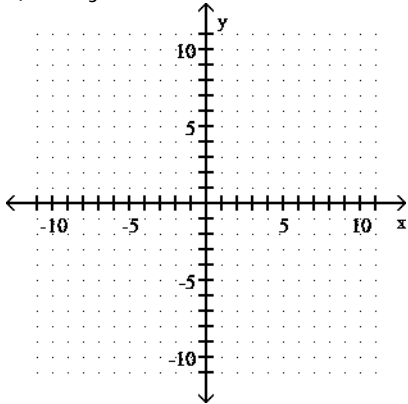

5) _____

A)

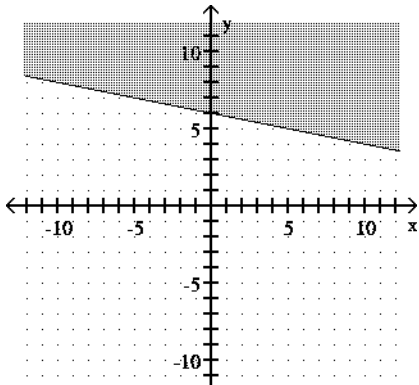

B)

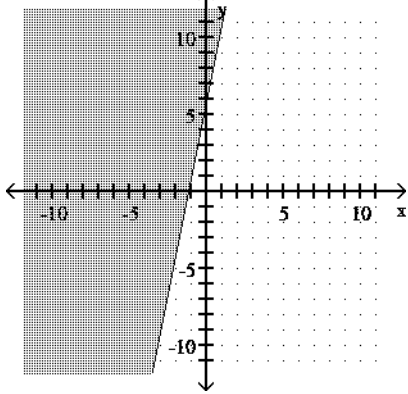

C)

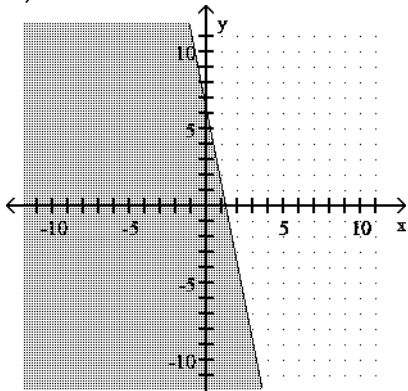

D)

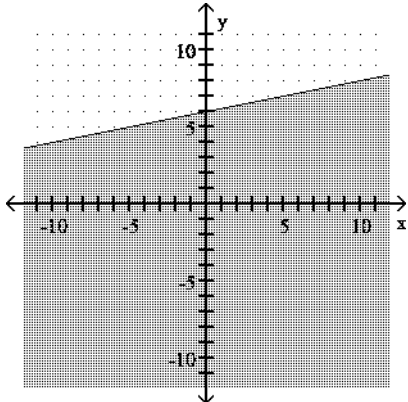

6) $x + 3y \geq -1$

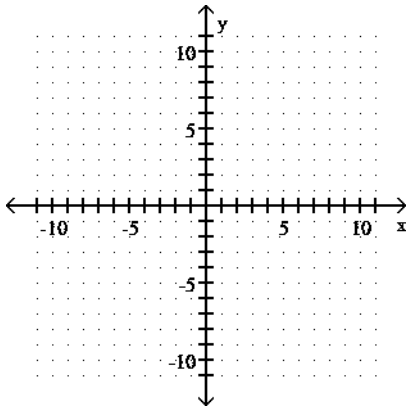

6) _____

A)

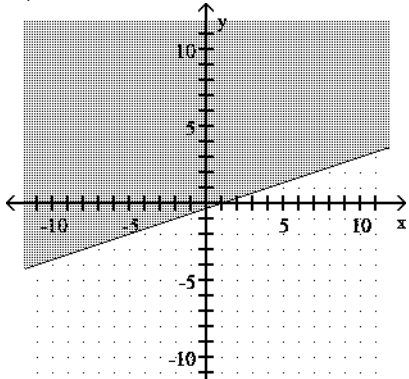

B)

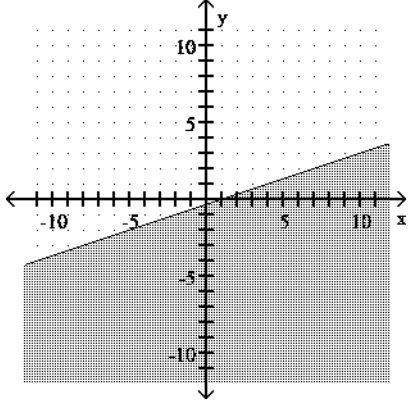

C)

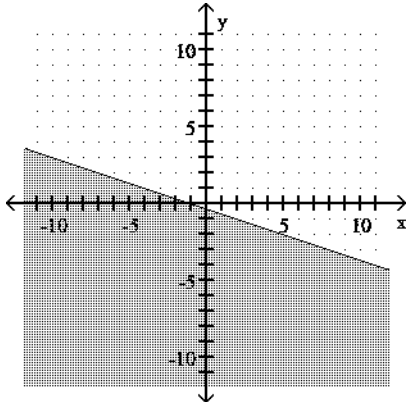

D)

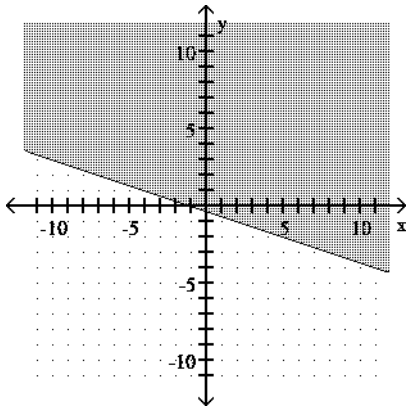

7) $x + y \leq 5$

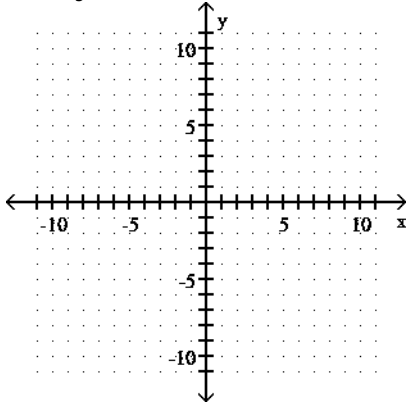

7) _____

A)

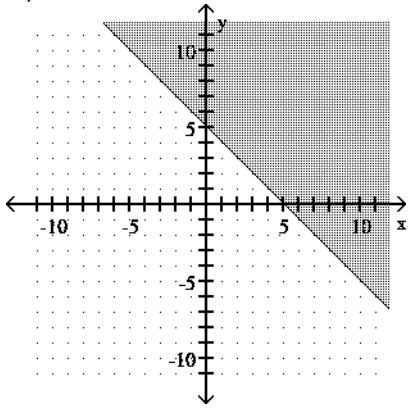

B)

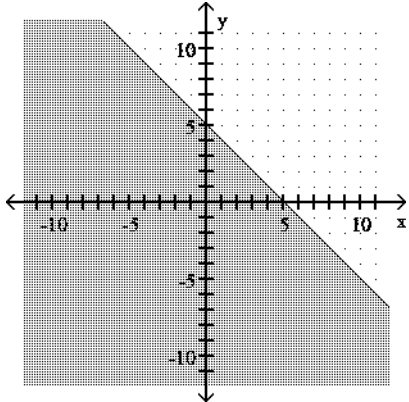

C)

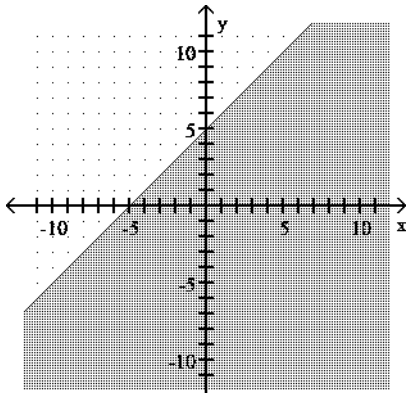

D)

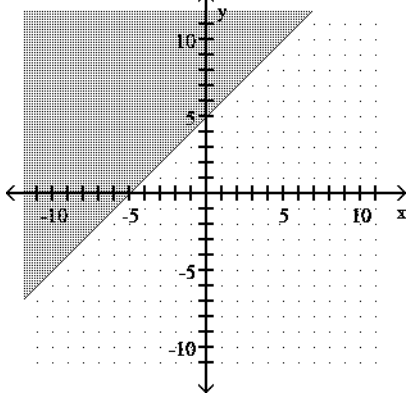

8) $x - y > -6$

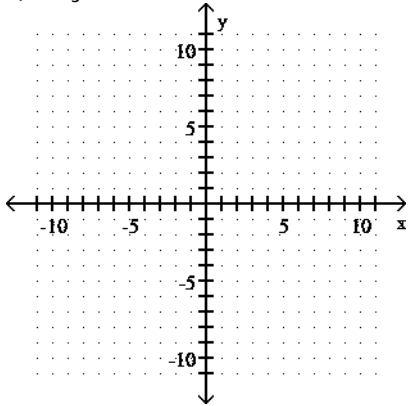

8) _____

A)

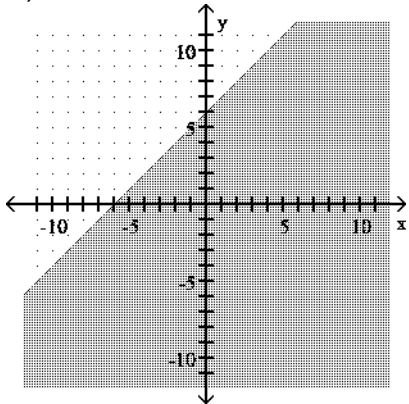

B)

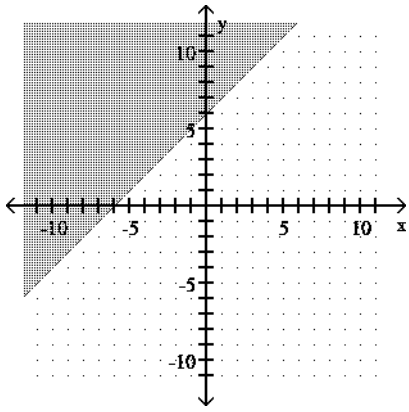

C)

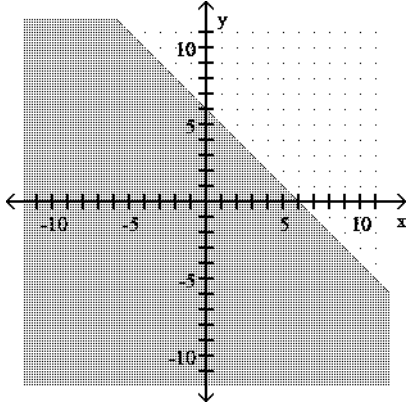
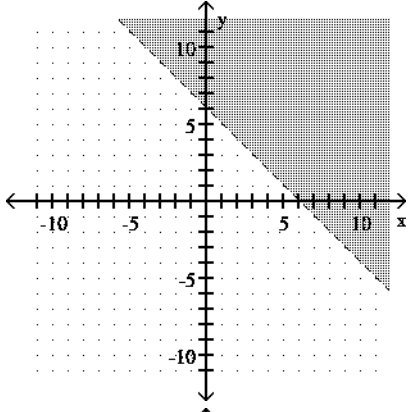

D)

9) $x + y < -2$

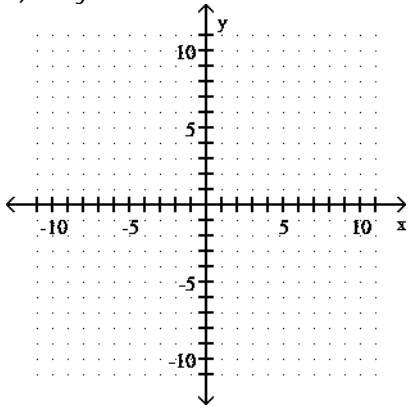

9) _____

A)

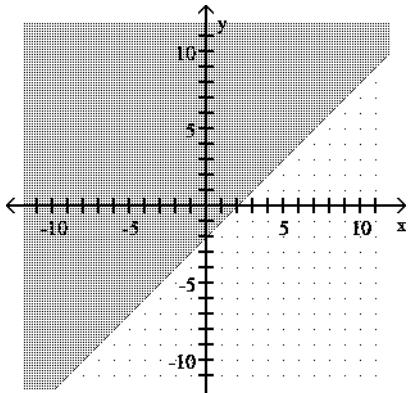

B)

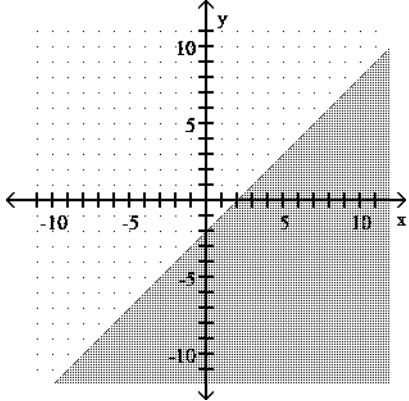

C)

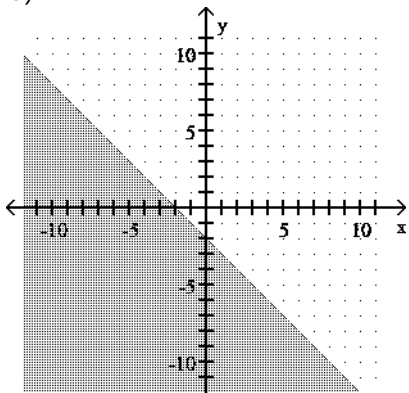

D)

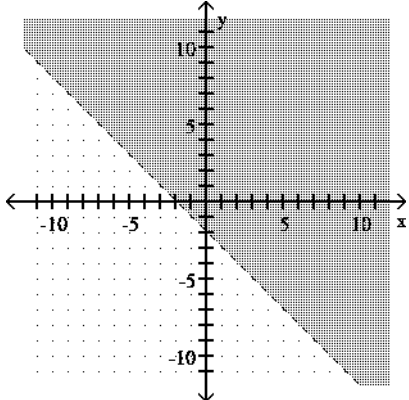

10) $x - y < -4$

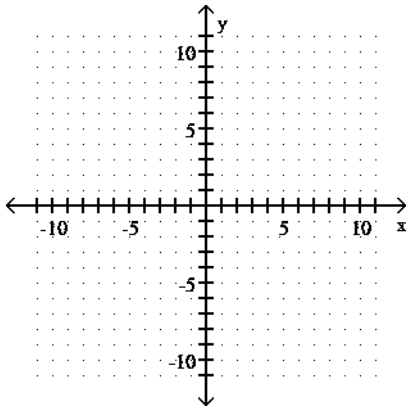

10) _____

A)

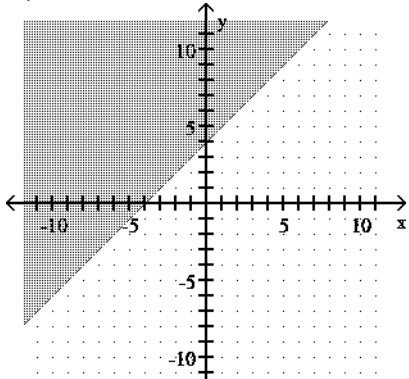

B)

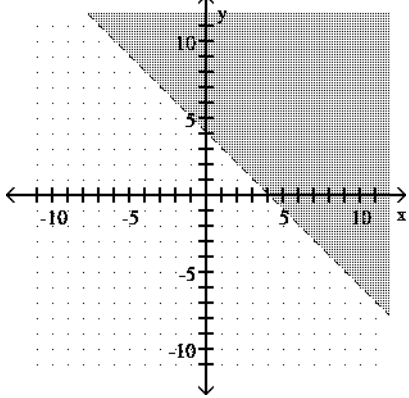

C)

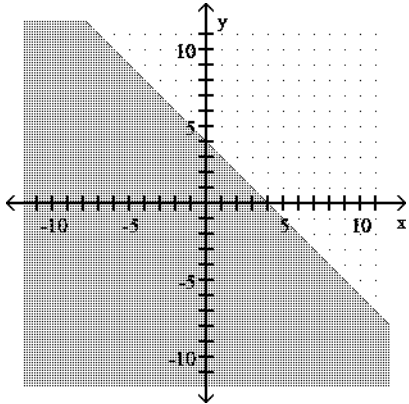

D)

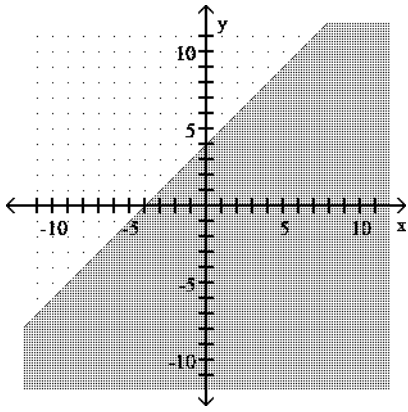

11) $x \geq 1$

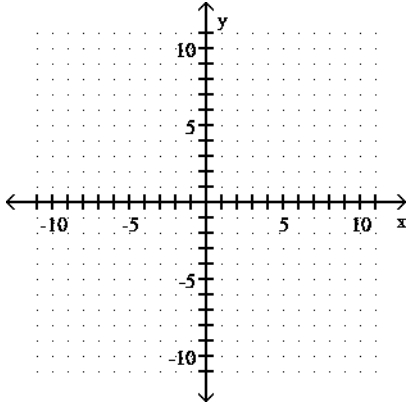

11) _____

A)

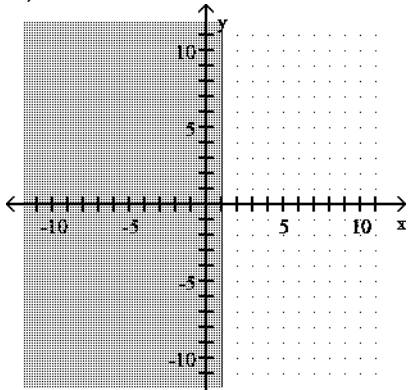

B)

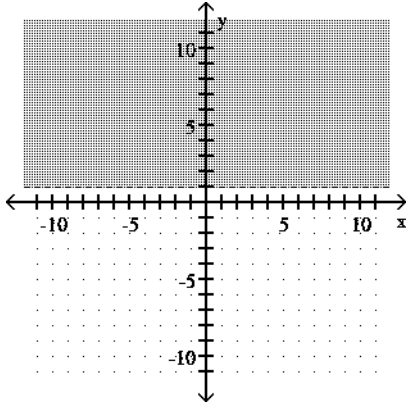

C)

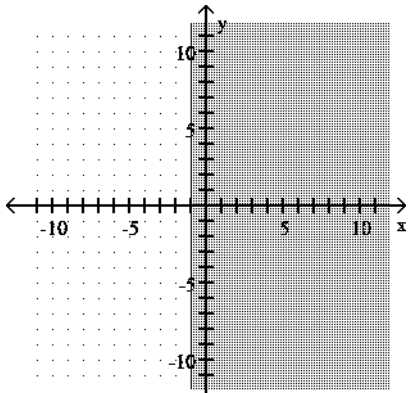

D)

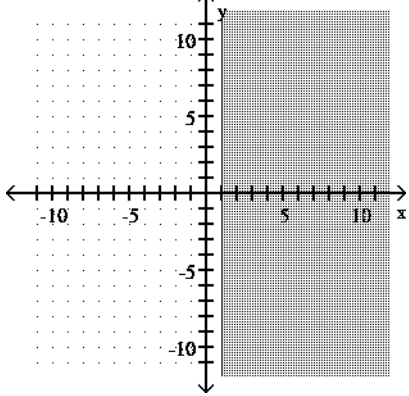

12) $y < -5$

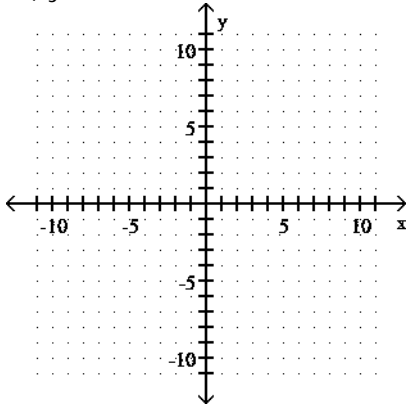

12) _____

A)

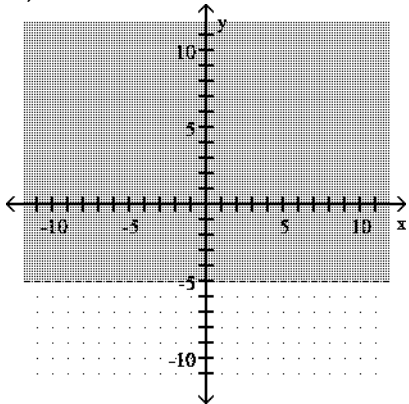

B)

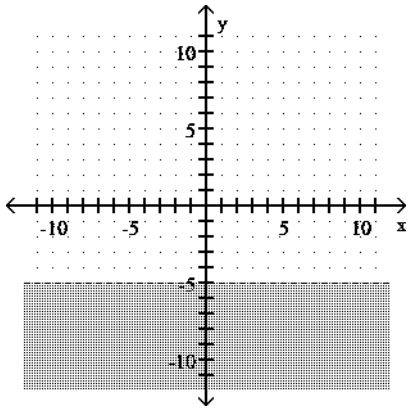

C)

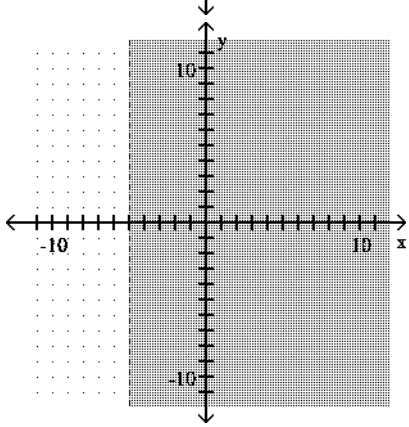
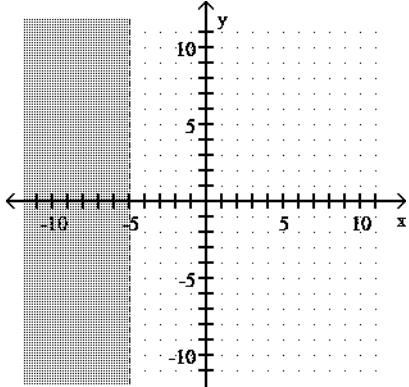

D)

13) $y \geq 4x$

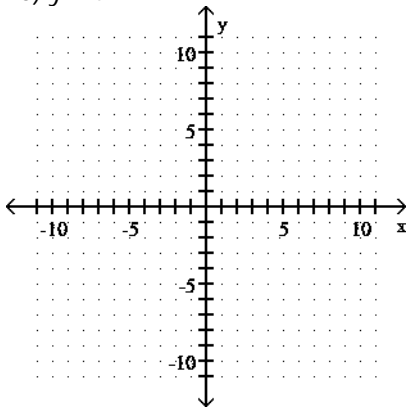

13) _____

A)

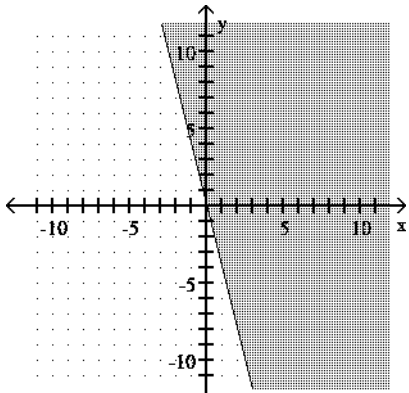

B)

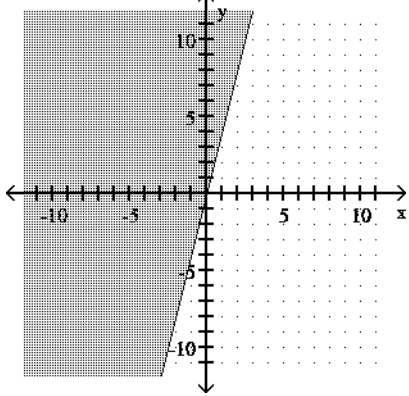

C)

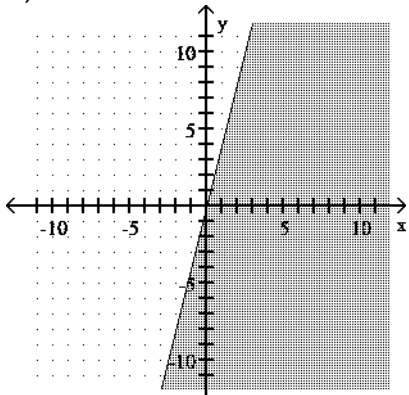

D)

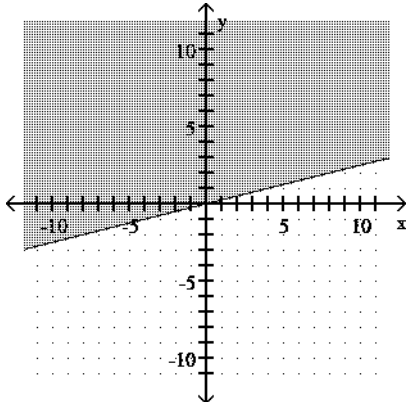

14) $3x + 4y \leq 12$

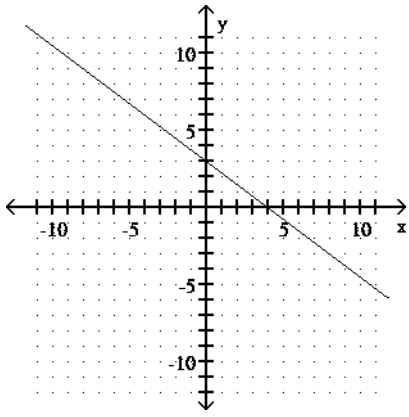

14) _____

A)

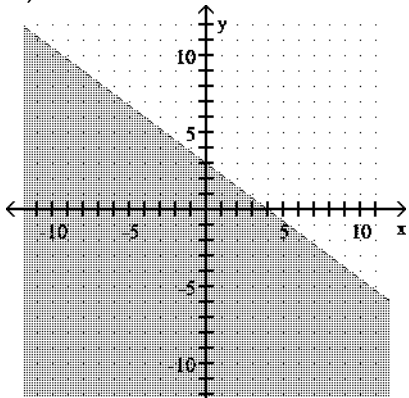

B)

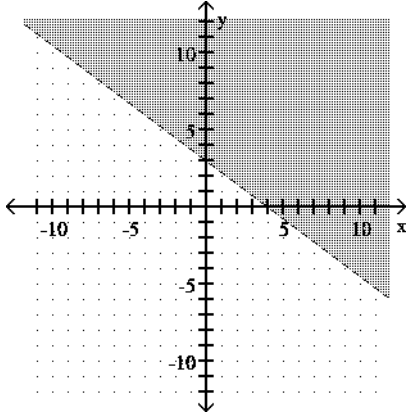

C)

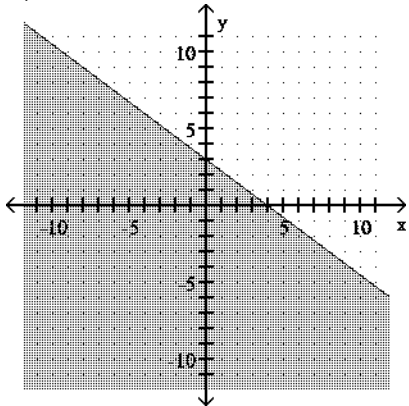

D)

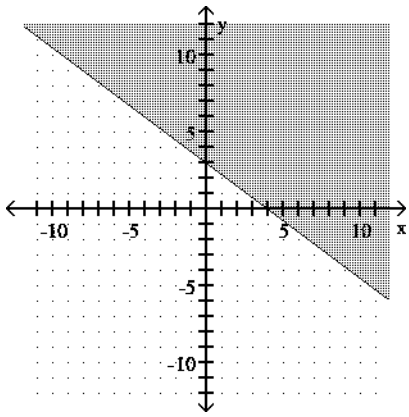

15) $-2x - 4y \leq 8$

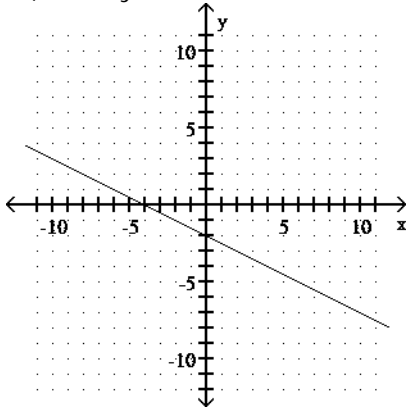

15) _____

A)

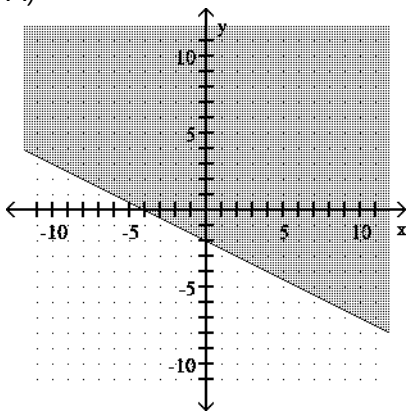

B)

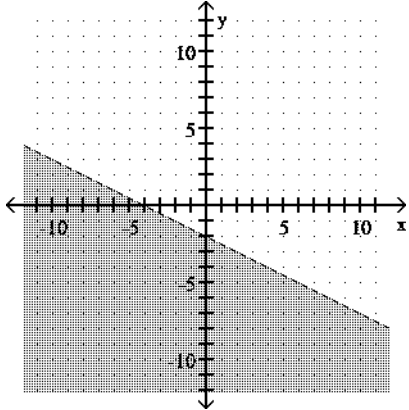

C)

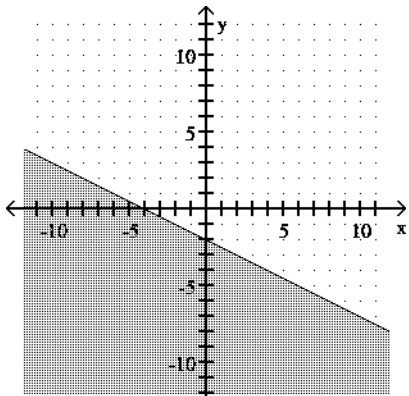

D)

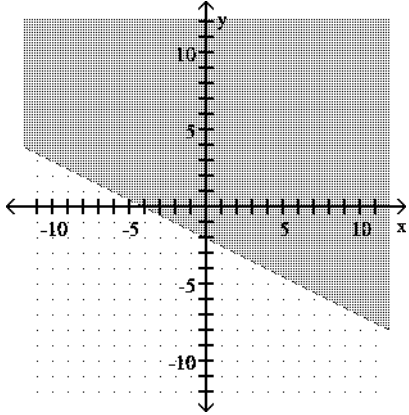

16) $2x + 3y \geq -6$

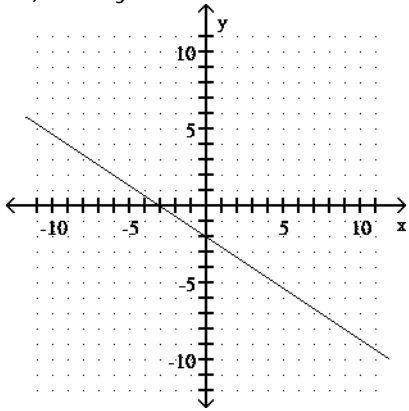

16) _____

A)

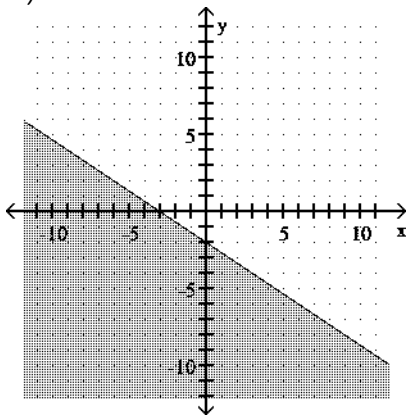

B)

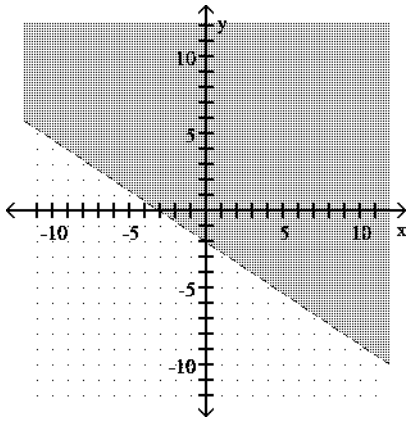

C)

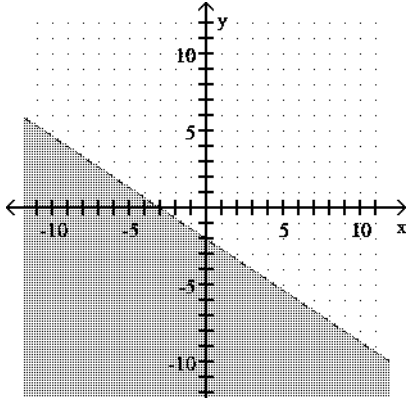

D)

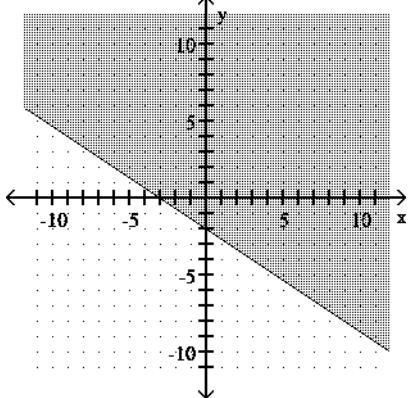

Graph the compound inequality.

17) $x + y \geq 2$ and $y \leq 2$

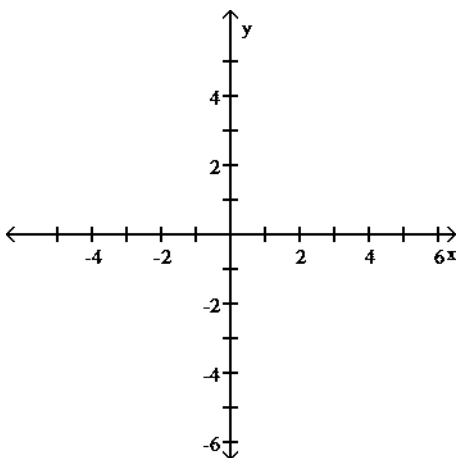

17) _____

A)

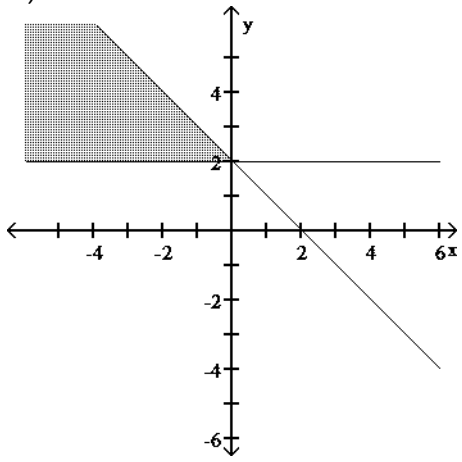

B)

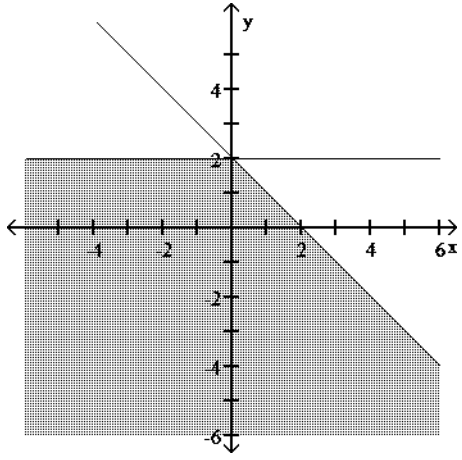

C)

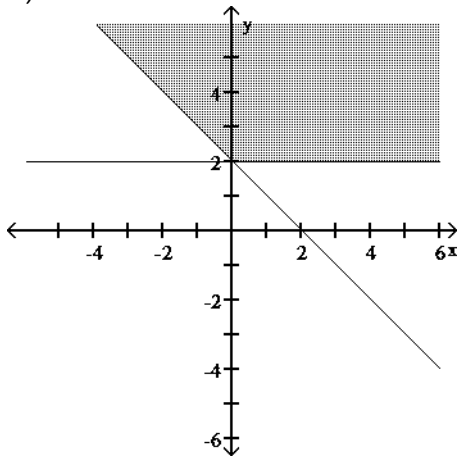

D)

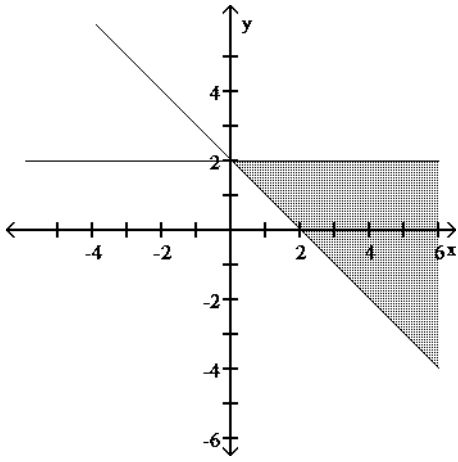

18) $2x - y > 4$ and $x \leq 4$

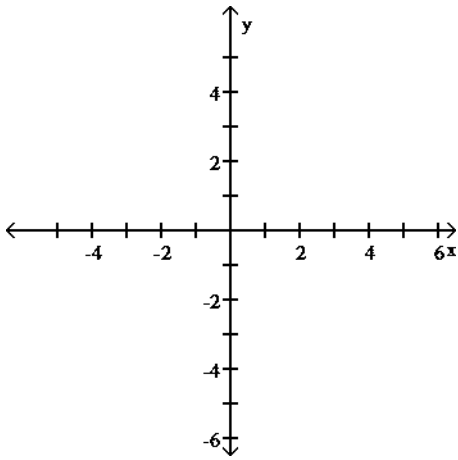

18) _____

A)

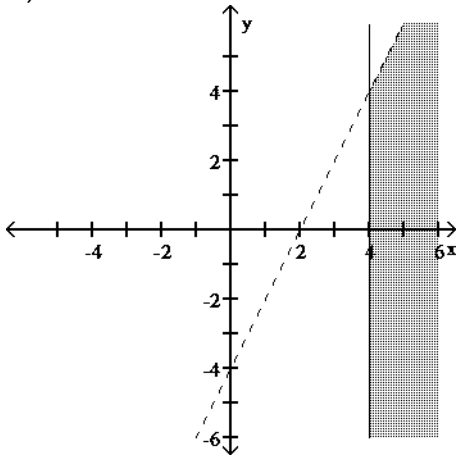

B)

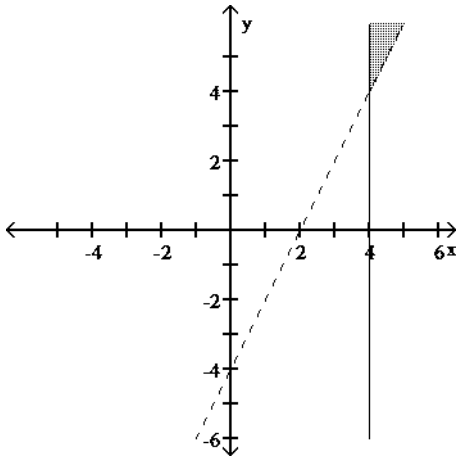

C)

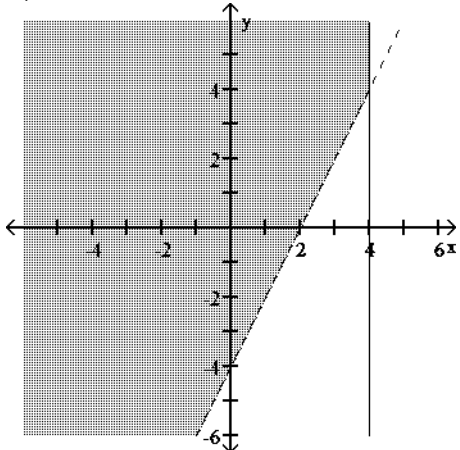

D)

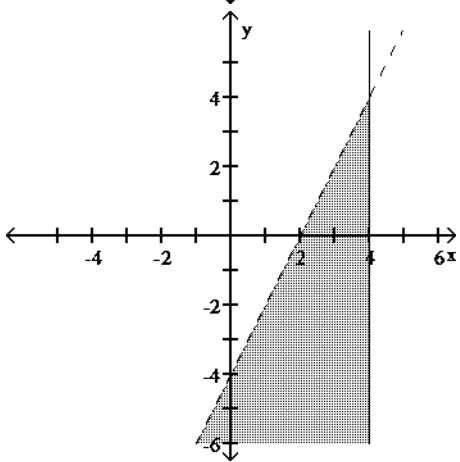

19) $2x + y \leq 4$ and $x - 1 > 0$

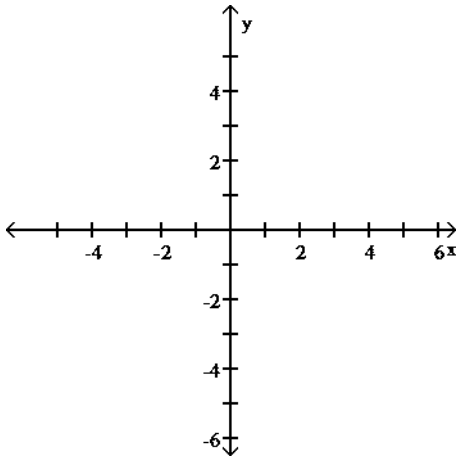

19) _____

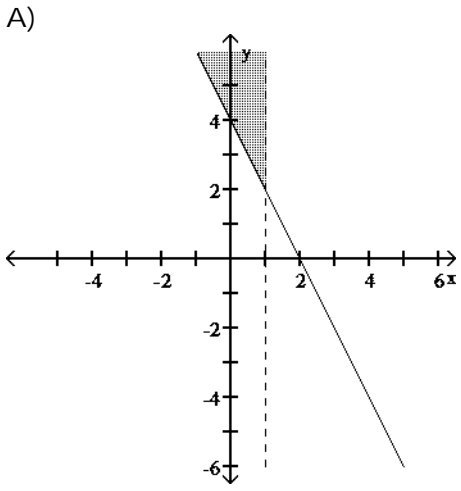

B)

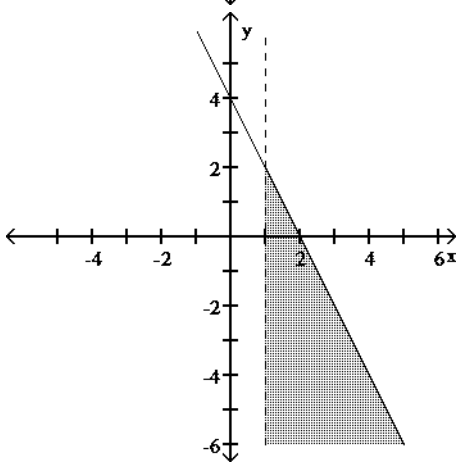

C)

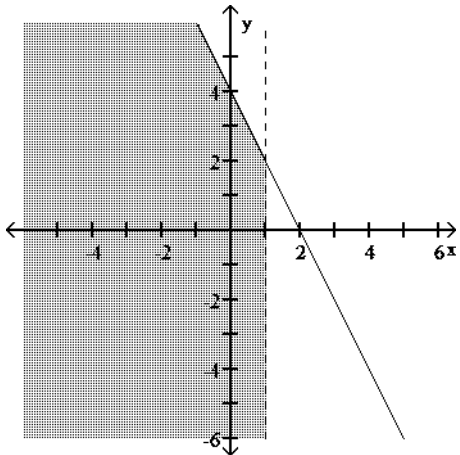

D)

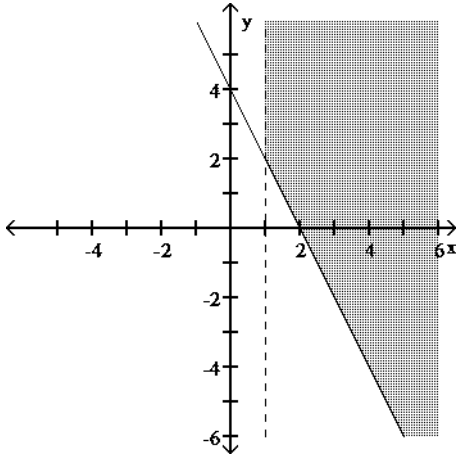

20) $3x - 2y \leq 6$ and $x - 1 > 0$

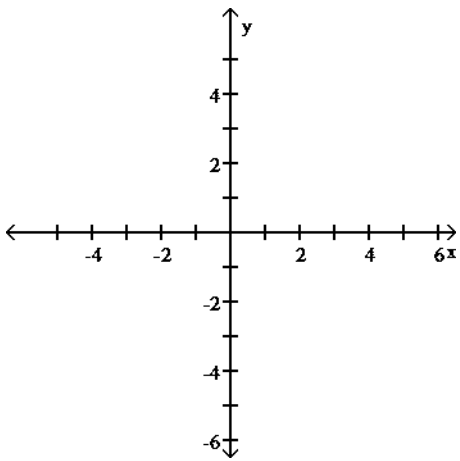

20) _____

A)

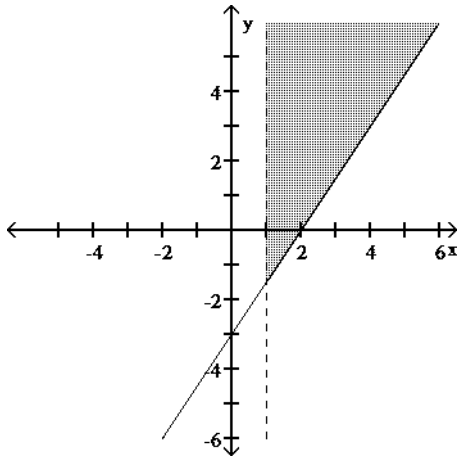

B)

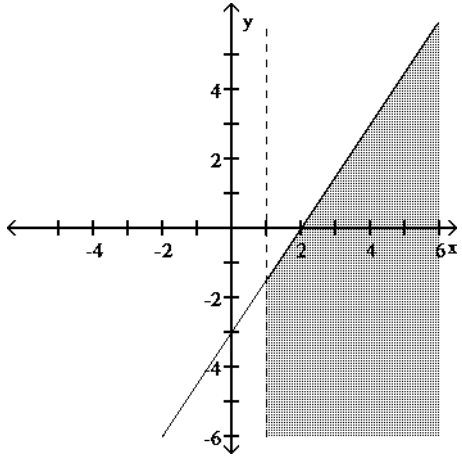

C)

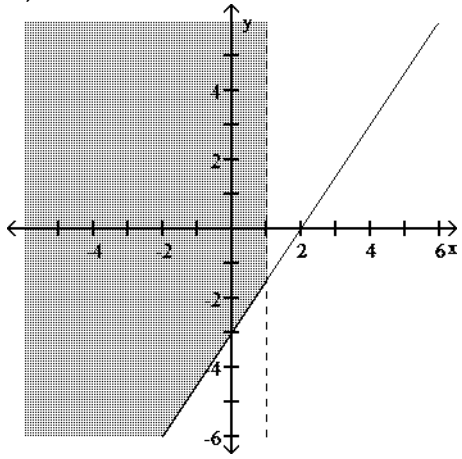

D)

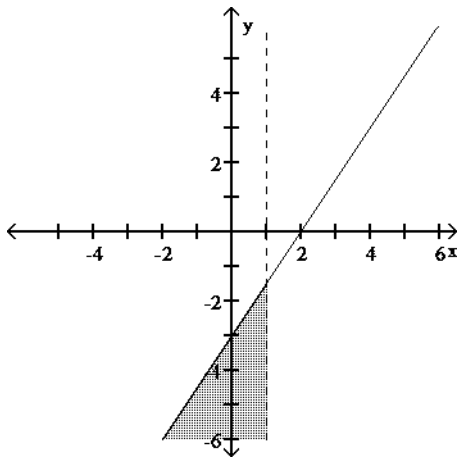

21) $x + 2y \leq 2$ and $x + y \geq 0$

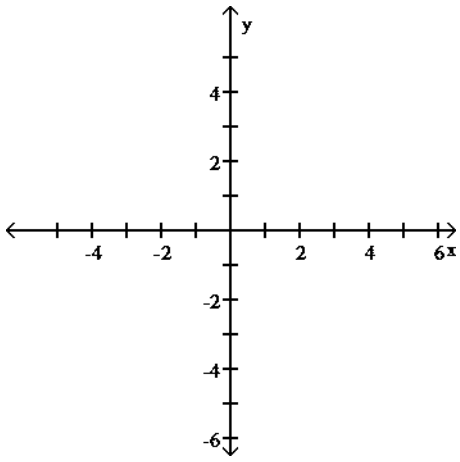

21) _____

A)

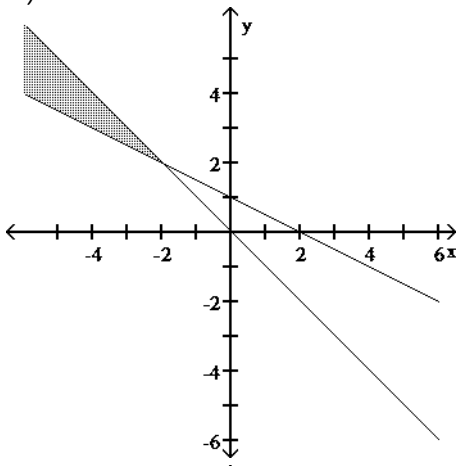

B)

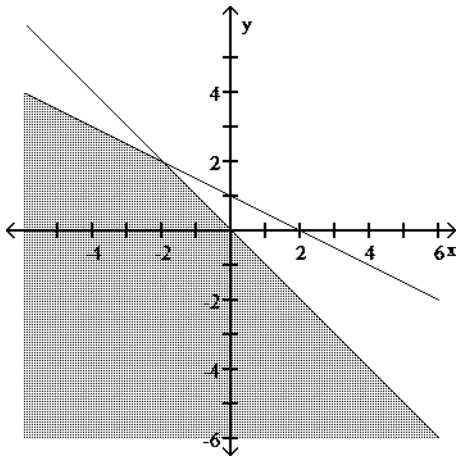

C)

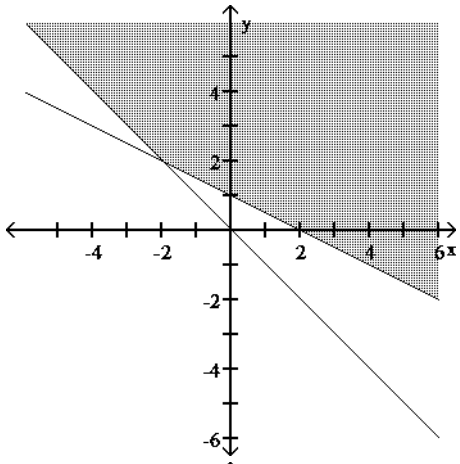

D)

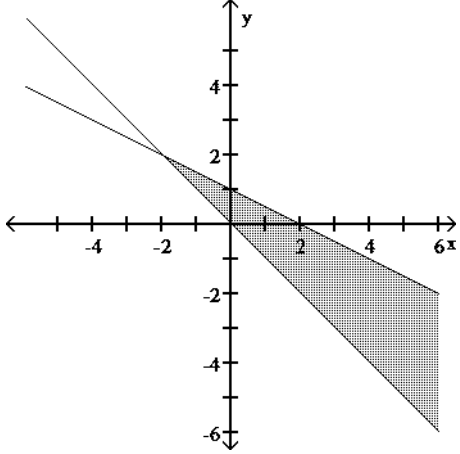

22) $x + 2y \geq 2$ and $x - y \leq 0$

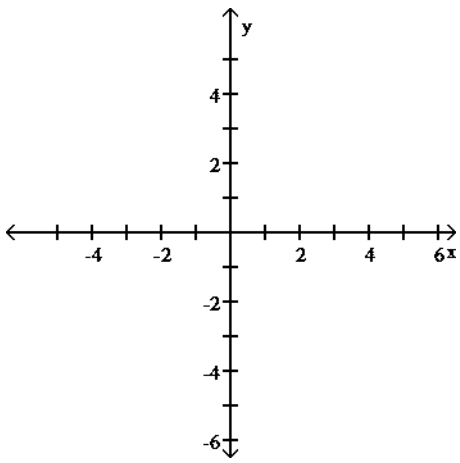

22) _____

A)

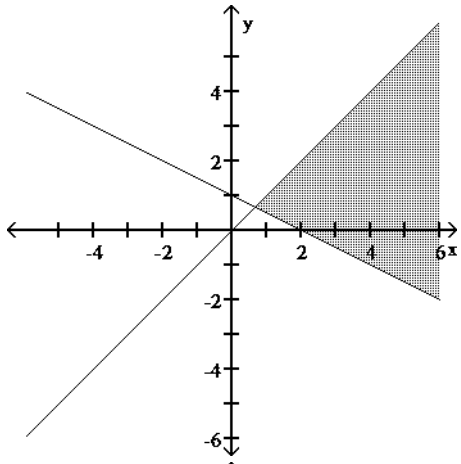

B)

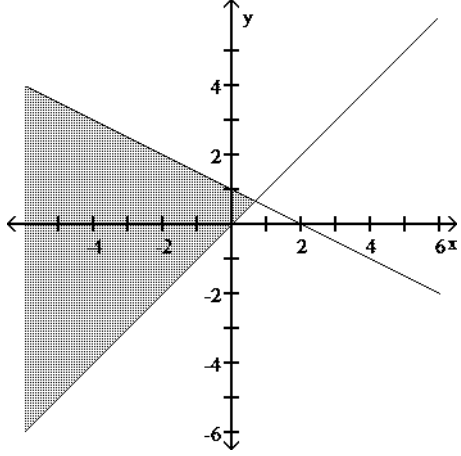

C)

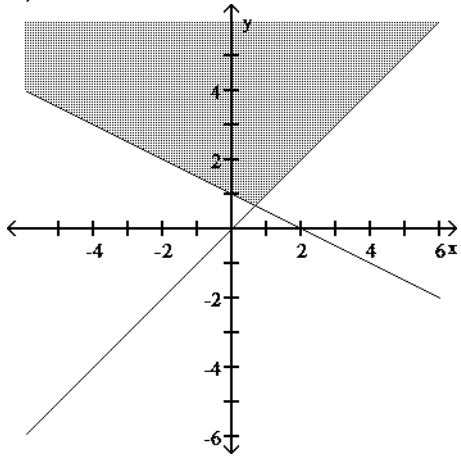

D)

Graph the solution set of the inequality in the rectangular coordinate plane.

23) $|x| \geq 3$

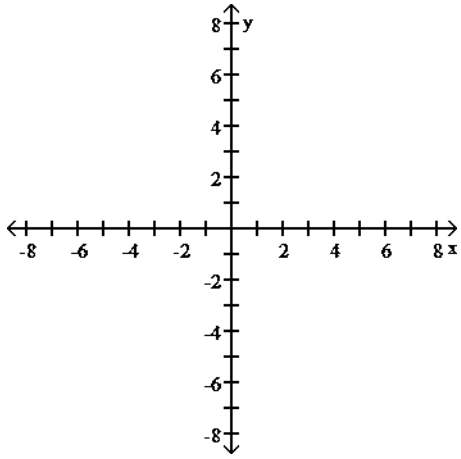

23) _____

A)

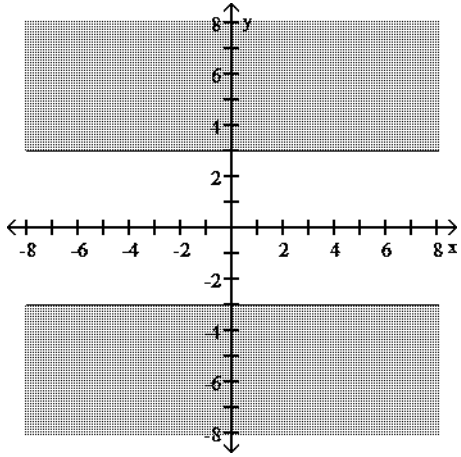

B)

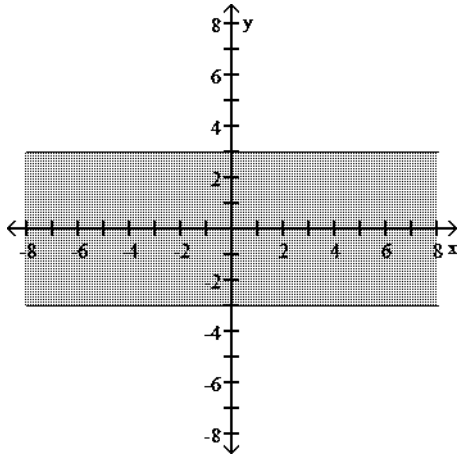

C)

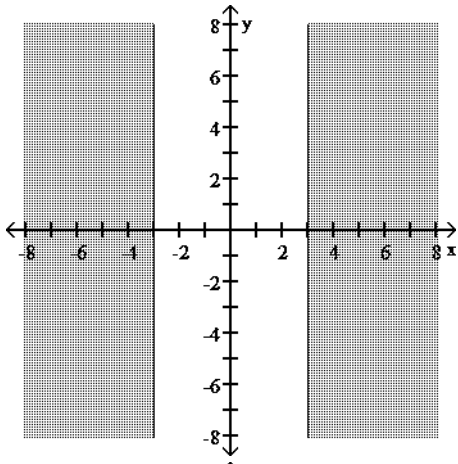

D)

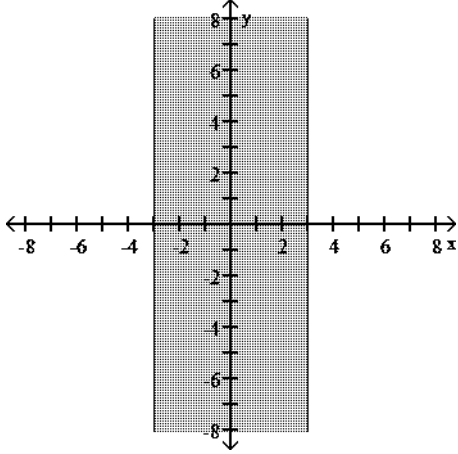

24) $|y| < 5$

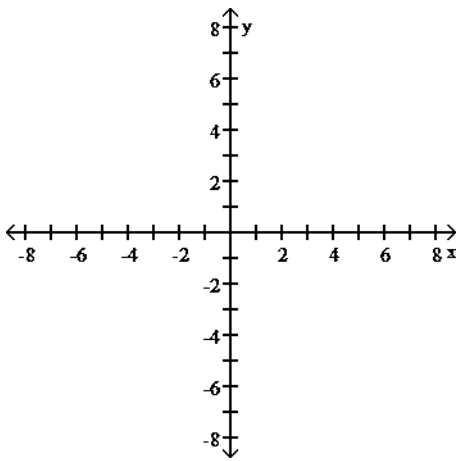

24) _____

A)

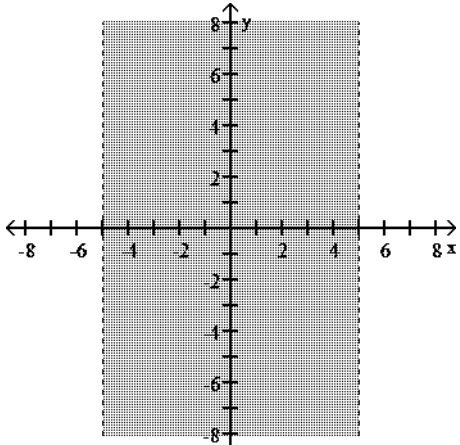

B)

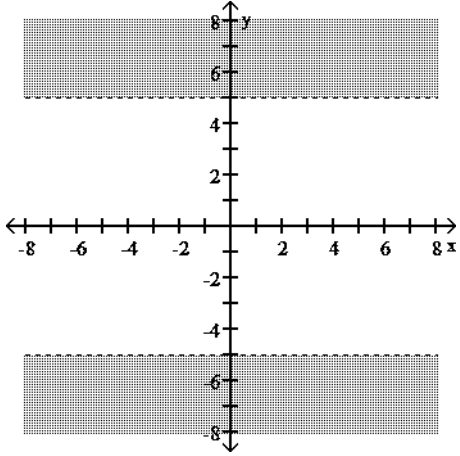

C)

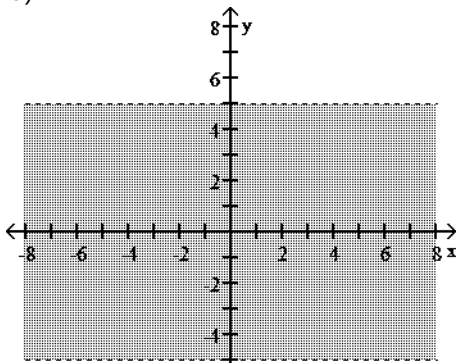

D)

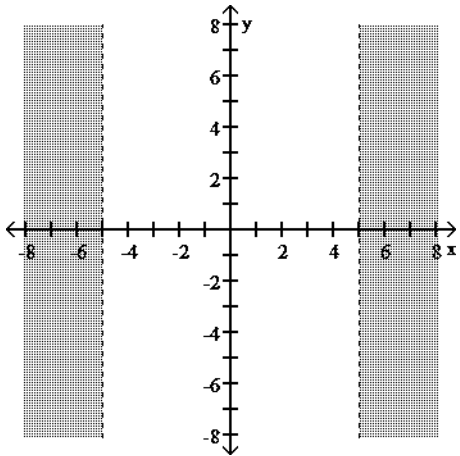

25) $|x + 1| < 4$

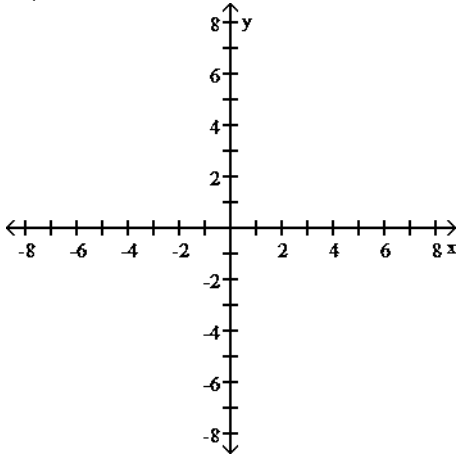

25) _____

A)

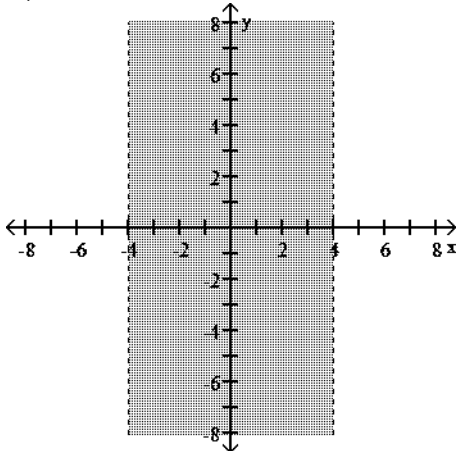

B)

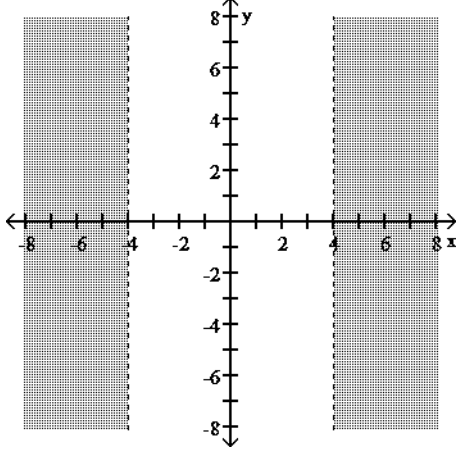

C)

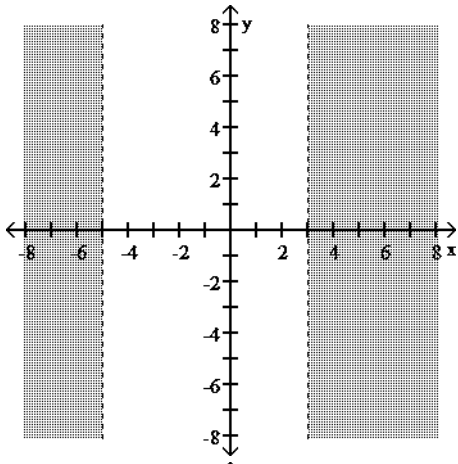

D)

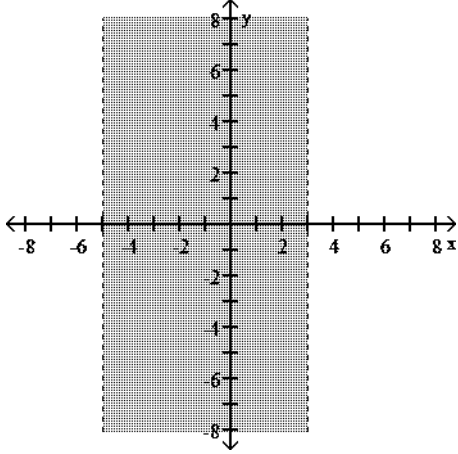

26) $|y - 3| > 2$

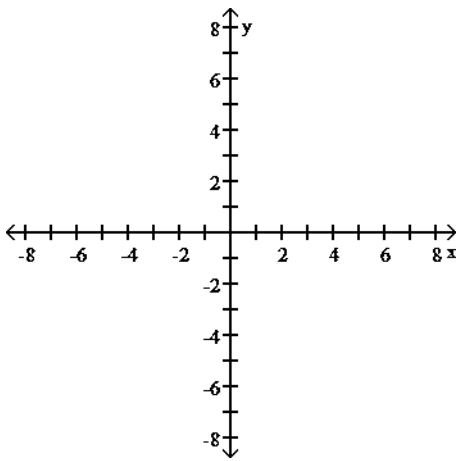

26) _____

A)

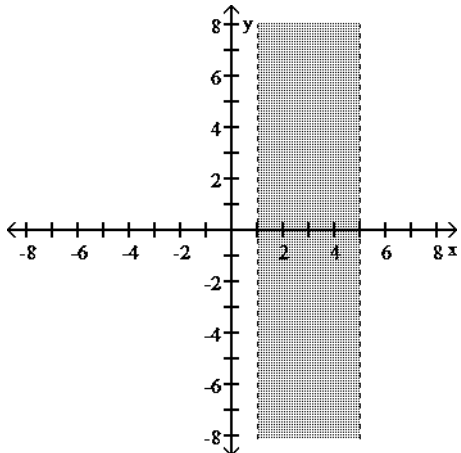

B)

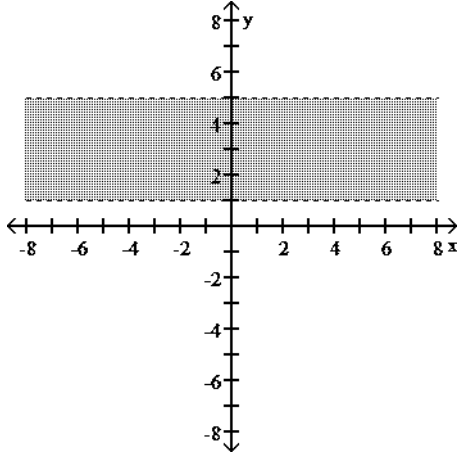

C)

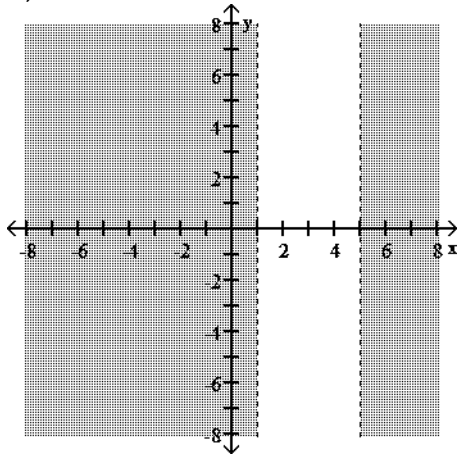

D)

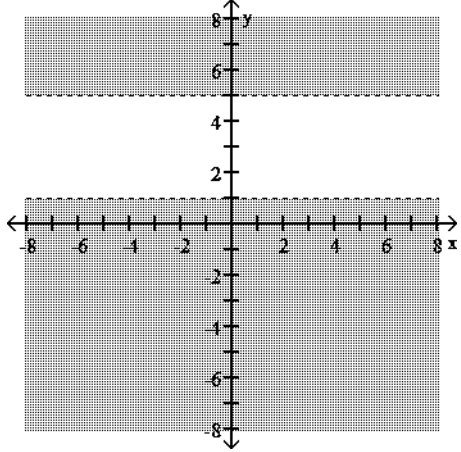

27) $|x + 1| > 4$

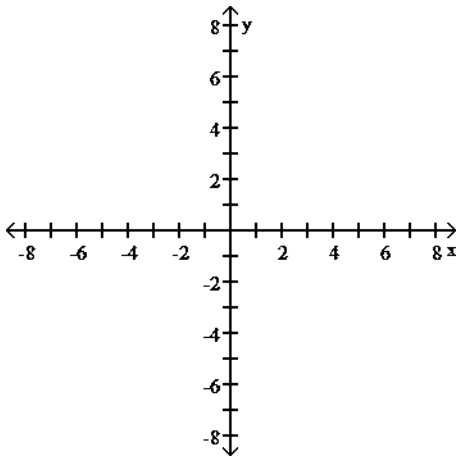

27) _____

A)

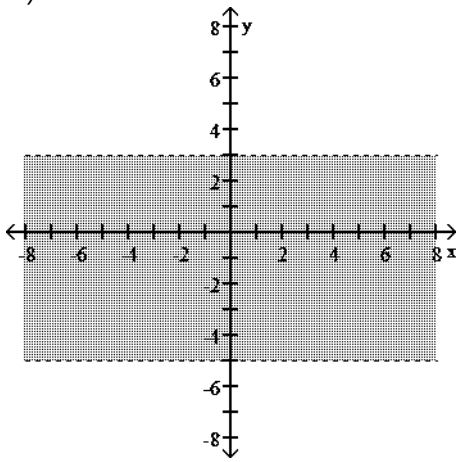

B)

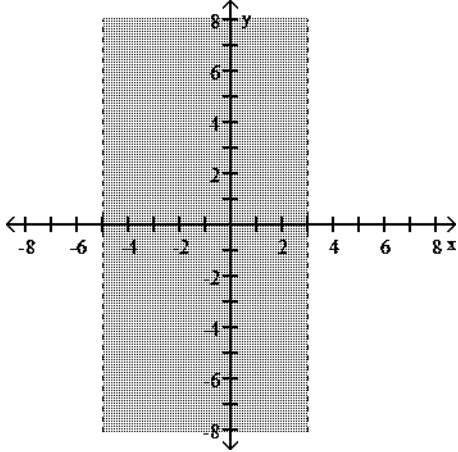

C)

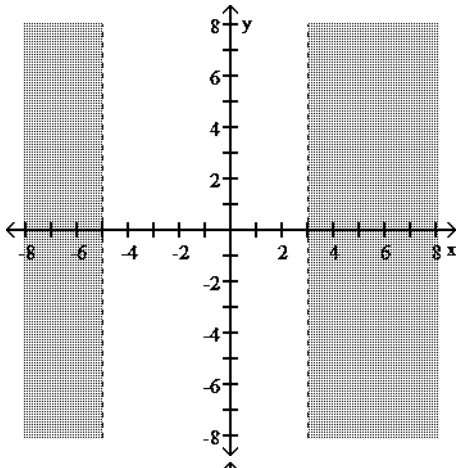

D)

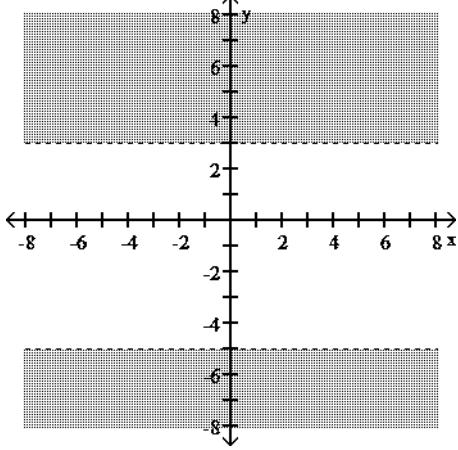

28) $|y| \geq 5$

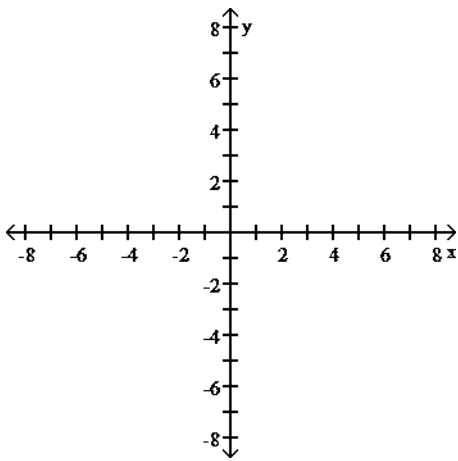

28) _____

A)

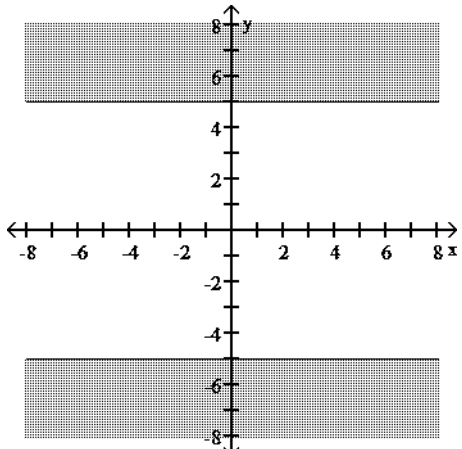

B)

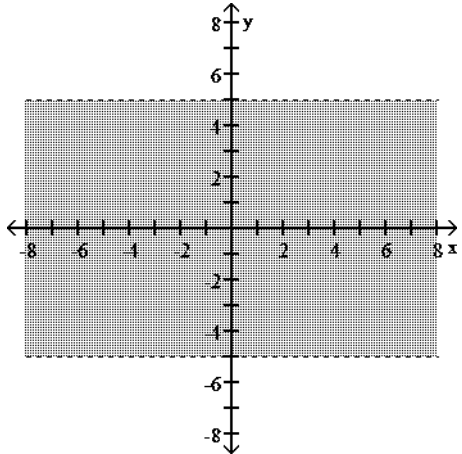

C)

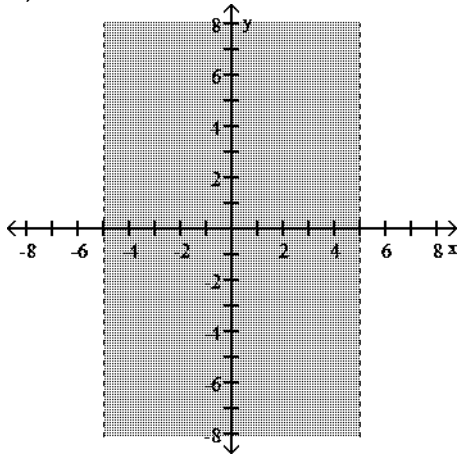

D)

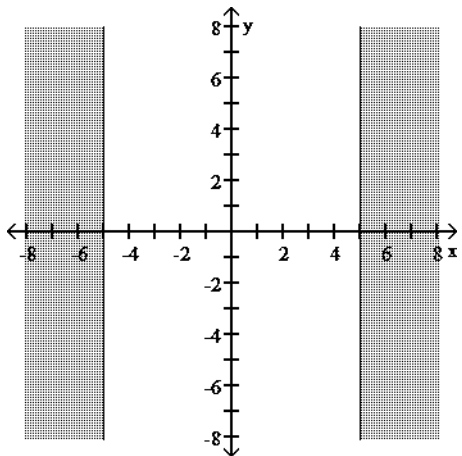

29) $|y + 3| < 2$

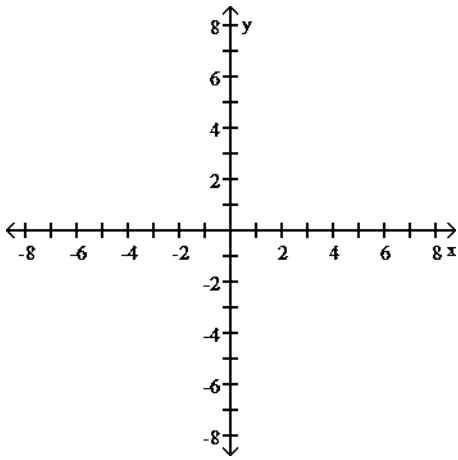

29) _____

A)

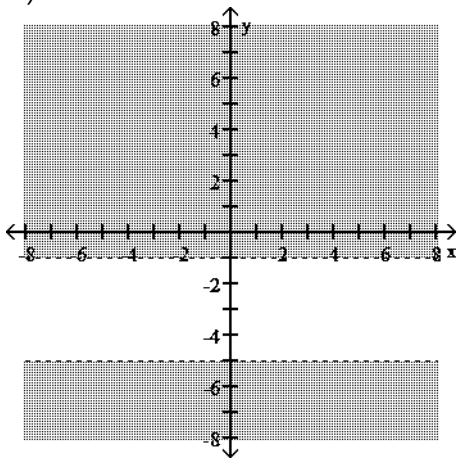

B)

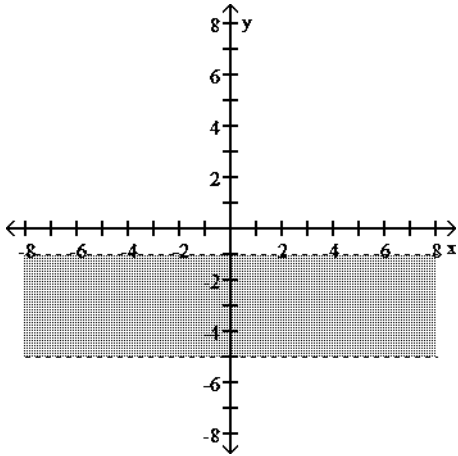

C)

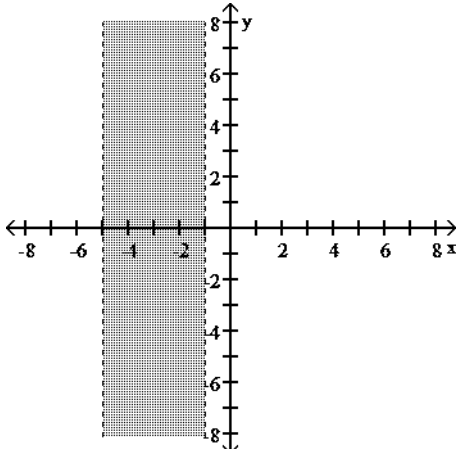

D)

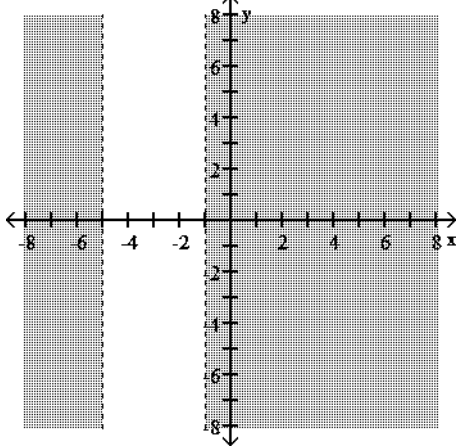

Graph the compound inequality.

30) $3x + 2y > 4$ or $x > 2$

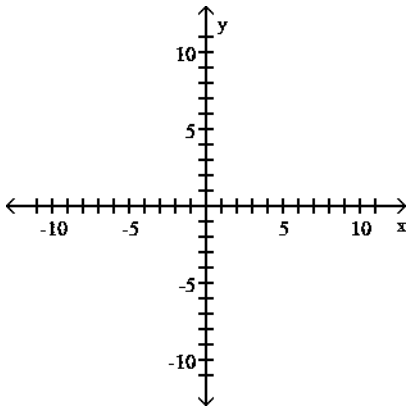

30) _____

A)

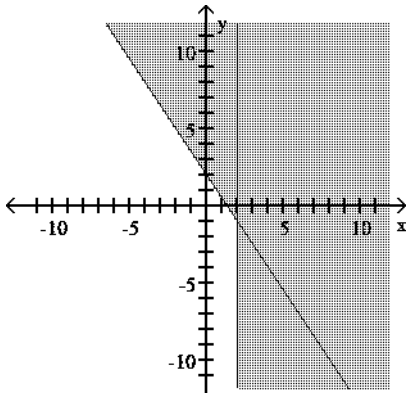

B)

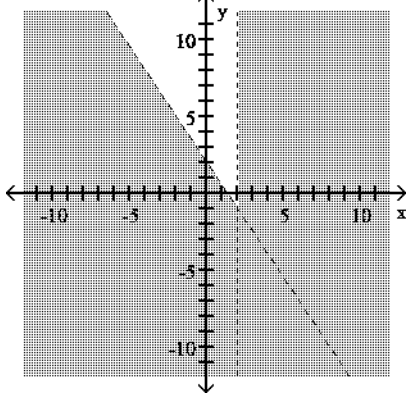

C)

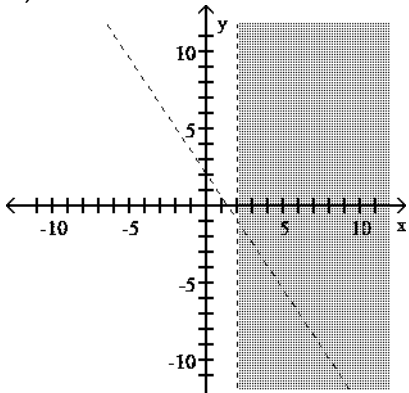

D)

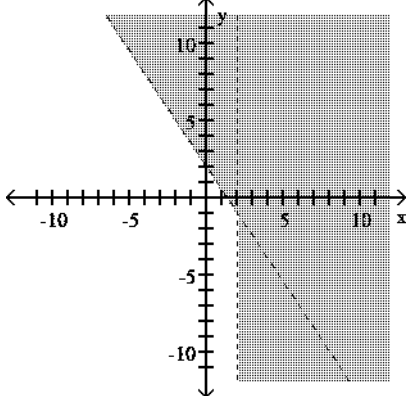

31) $2x + y < 6$ or $3x - 2y > 5$

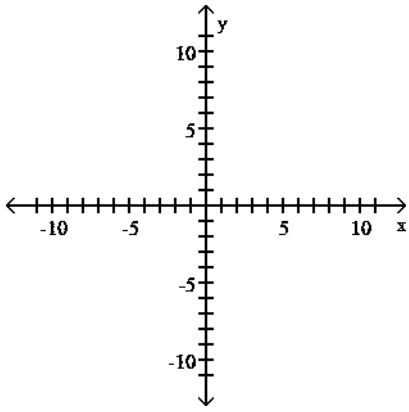

31) _____

A)

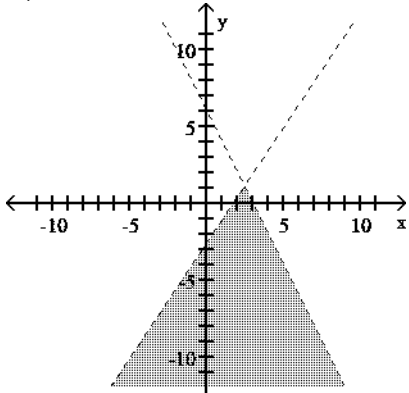

B)

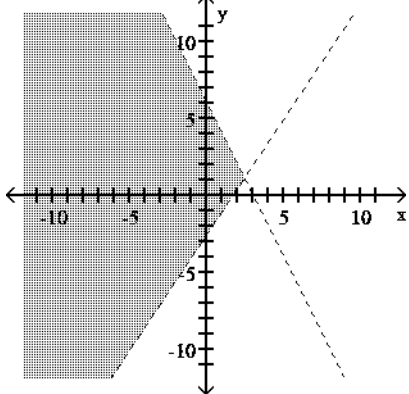

C)

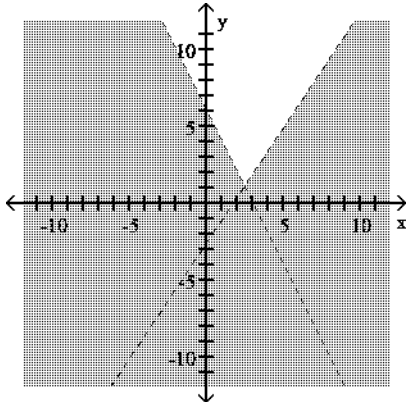

D)

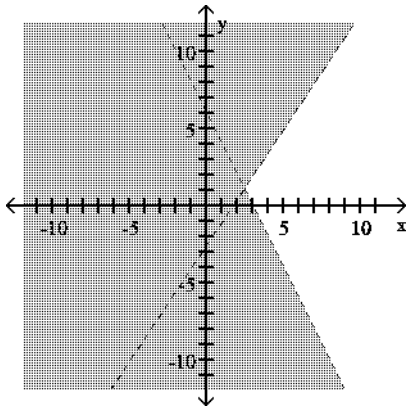

32) $4x < y + 2$ or $y < -2$

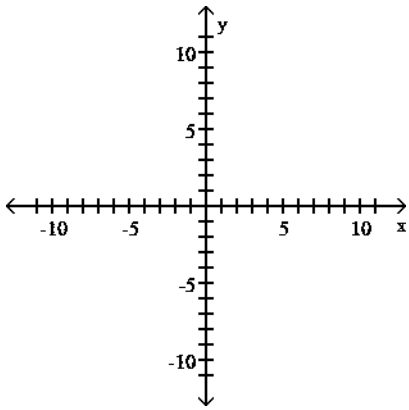

32) _____

A)

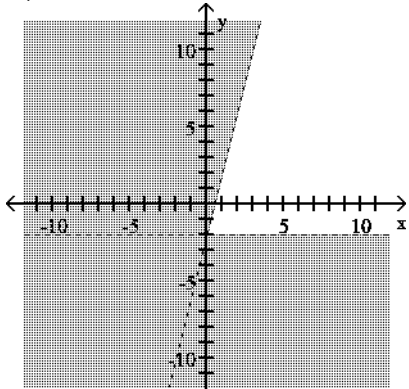

B)

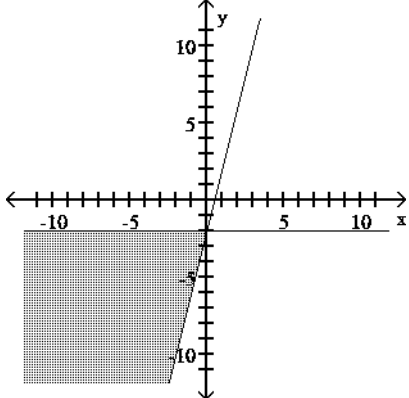

C)

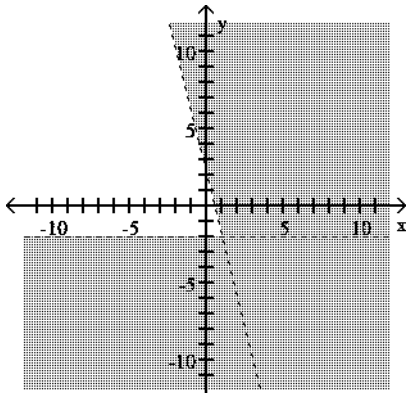

D)

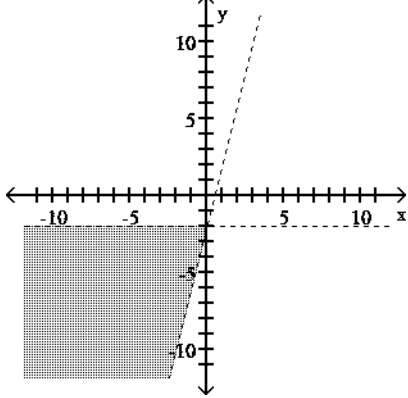

33) $x + 5 \geq 2y$ or $x \leq 3$

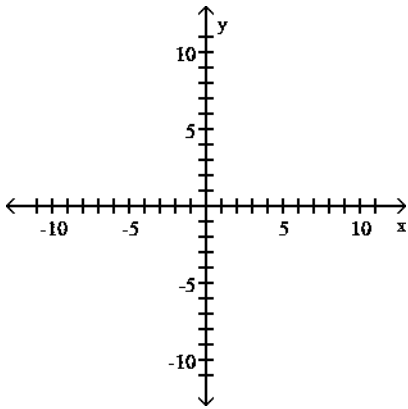

33) _____

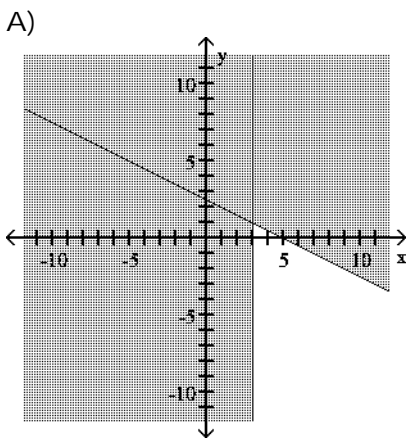

B)

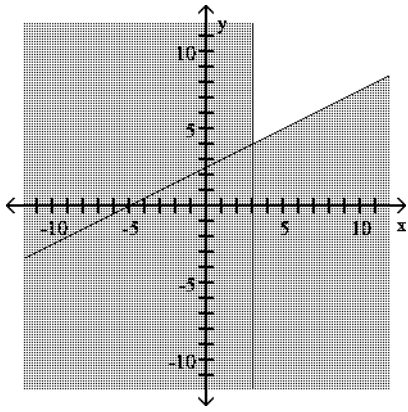

C)

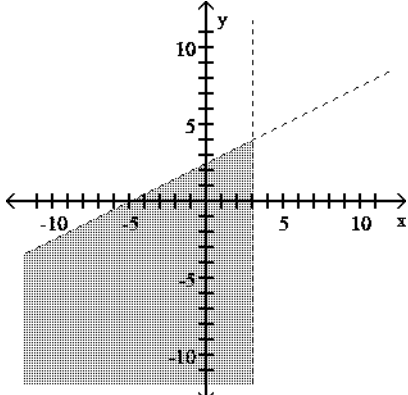

D)

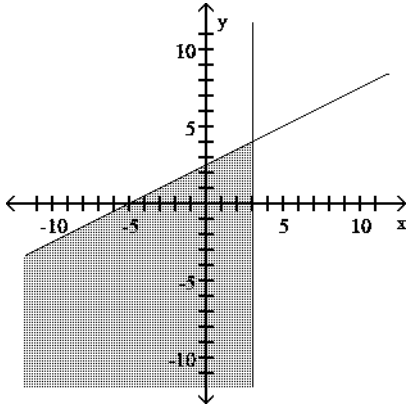

34) $3x + y \geq 3$ or $x - 4y \leq 1$

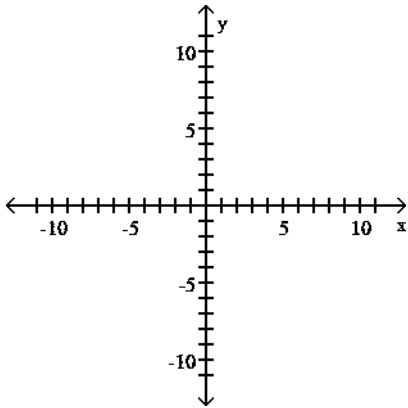

34) _____

A)

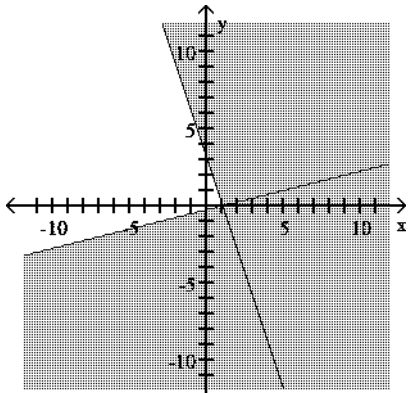

B)

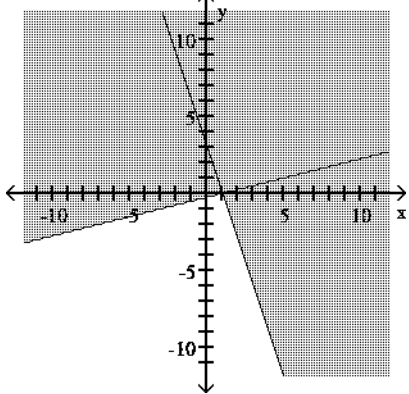

C)

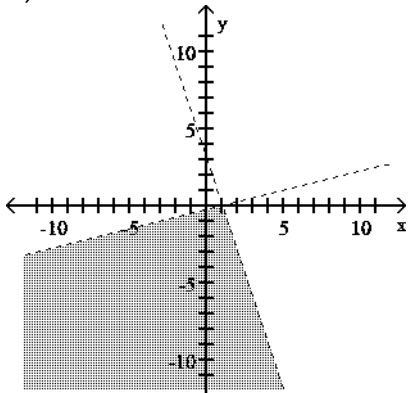

D)

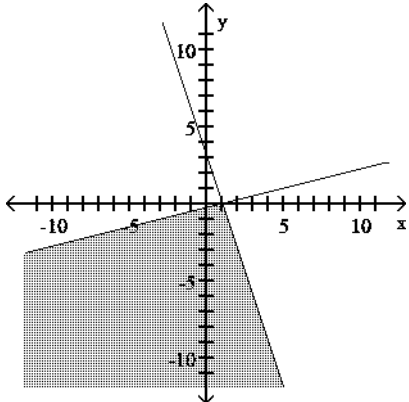

35) $2x + 2y > 1$ or $3x + 4y > 2$

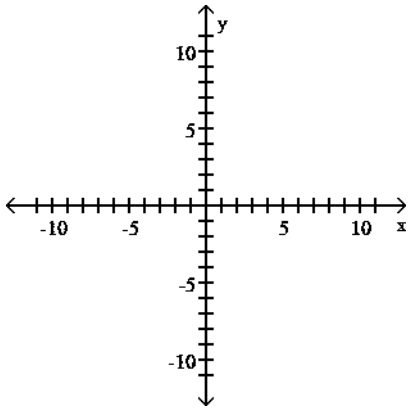

35) _____

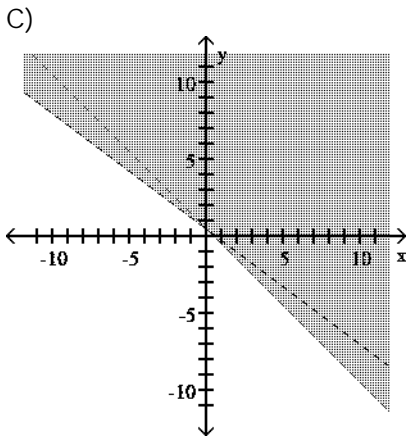
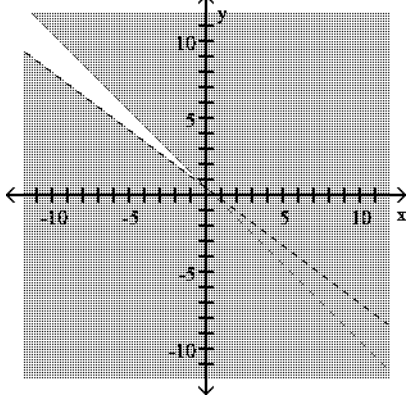
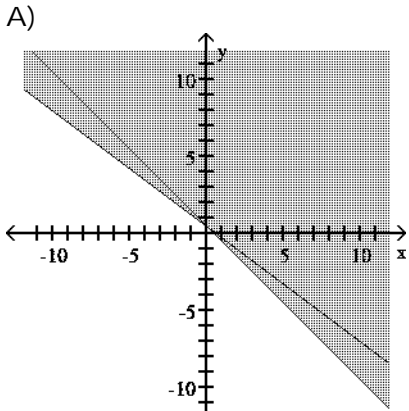

D)

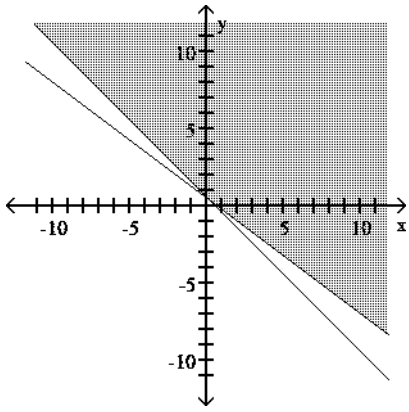

36) $3x + 5y \geq 3$ or $y \geq 3$

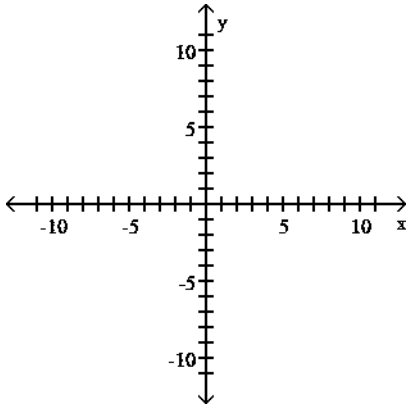

36) _____

A)

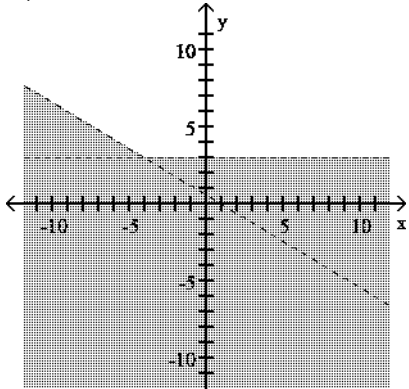

B)

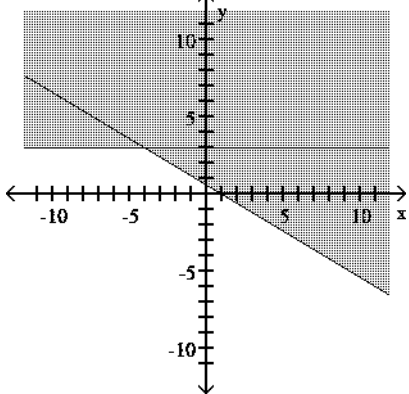

C)

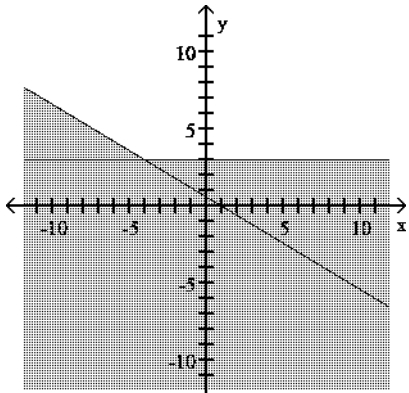

D)

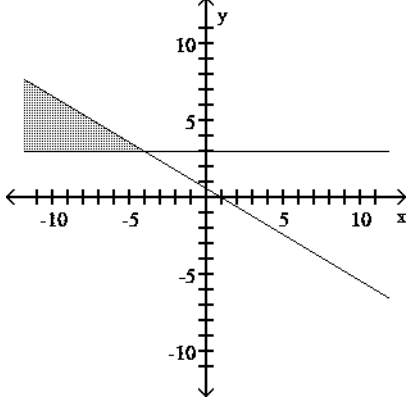

37) $x - 5y \leq 4$ or $5x + y \leq 3$

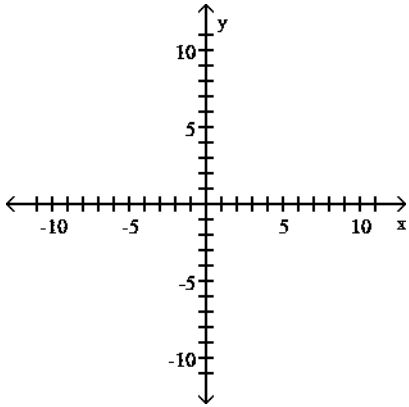

37) _____

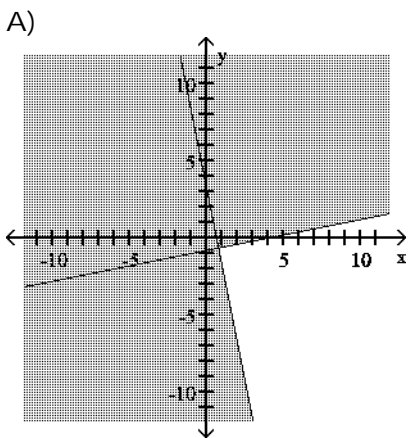

B)

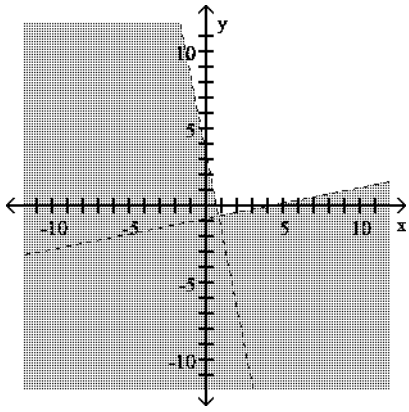

C)

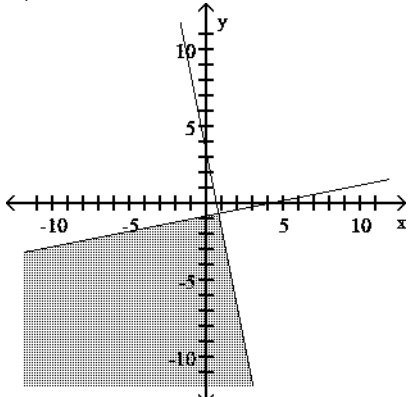

D)

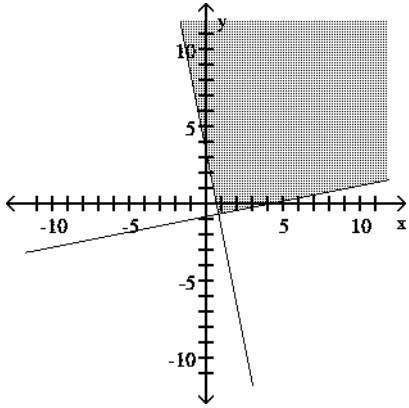

38) $x > y + 1$ or $y > -1$

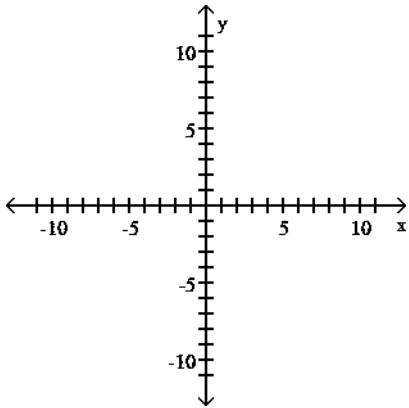

38) _____

A)

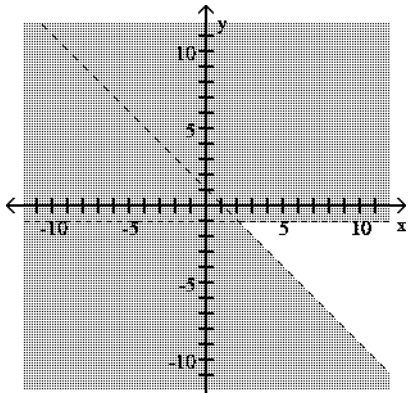

B)

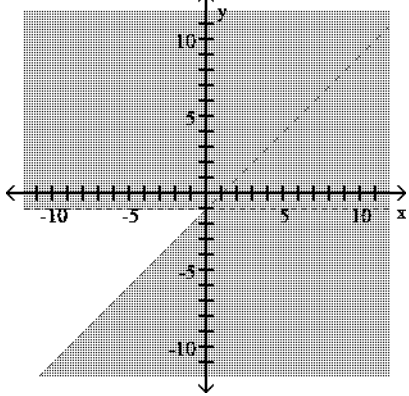

C)

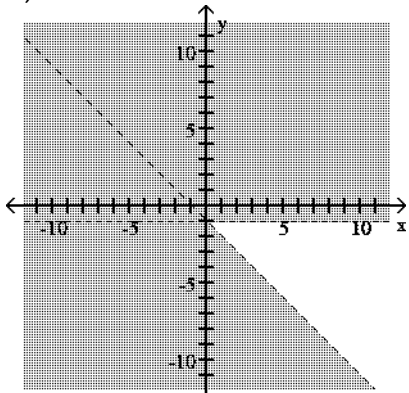

D)

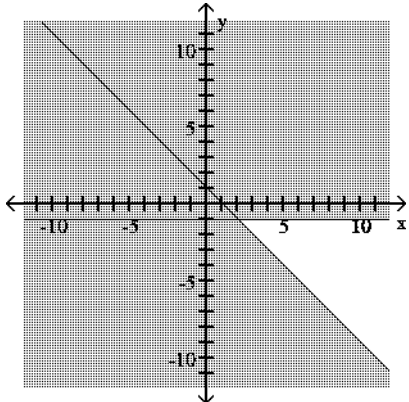

Choose the inequality that best matches the given calculator graph.

39)

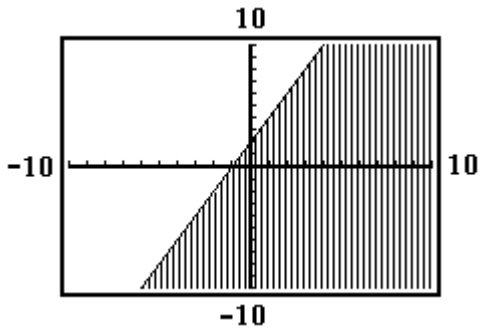

39) _____

- A) $y \geq -2x - 2$ B) $y \leq 2x + 2$ C) $y \leq -2x - 2$ D) $y \geq 2x + 2$

40)

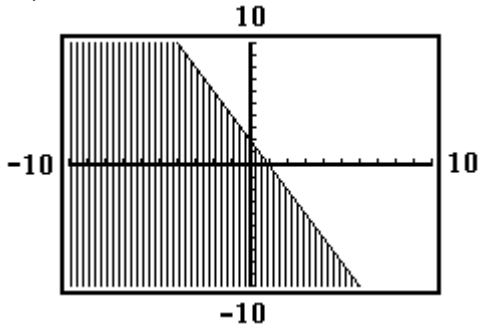

40) _____

- A) $y \leq 2x - 2$ B) $y \leq -2x - 2$ C) $y \geq -2x + 2$ D) $y \leq -2x + 2$

41)

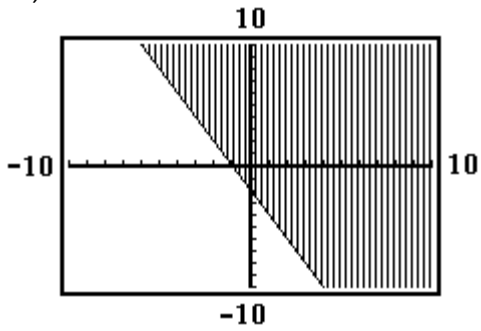

41) _____

- A) $y \geq 2x - 2$ B) $y \geq -2x - 2$ C) $y \leq -2x - 2$ D) $y \leq 2x - 2$

42)

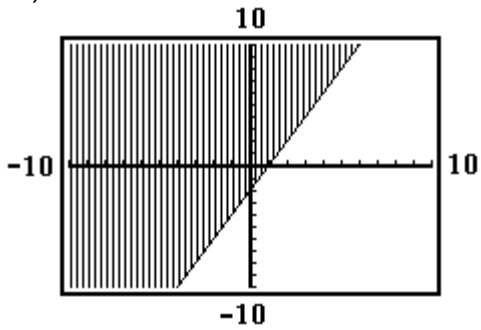

42) _____

- A) $y \leq -2x + 2$ B) $y \geq -2x - 2$ C) $y \geq 2x - 2$ D) $y \leq 2x - 2$

43)

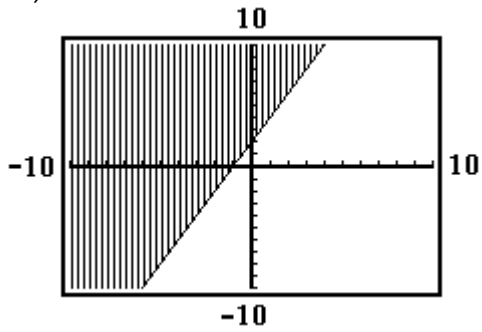

43) _____

- A) $y \geq -x + 1$ B) $y \leq x - 1$ C) $y \geq 2x + 2$ D) $y \leq 2x + 2$

The graph of the linear equation y_1 is shown on a graphing calculator screen, along with the x-value of the x-intercept of the line. Use the screen to solve the following equation or inequality.

44) $y_1 = 0$

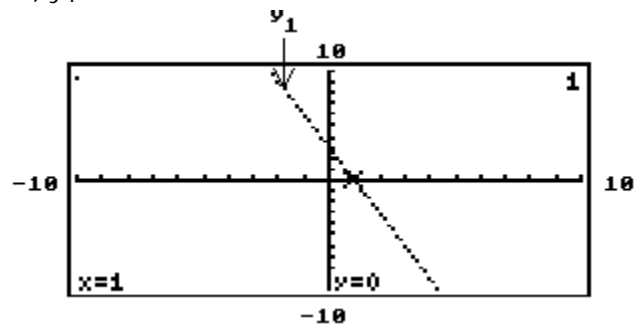

44) _____

- A) {0} B) {3}
 C) {1} D) Cannot be determined

45) $y_1 = 0$

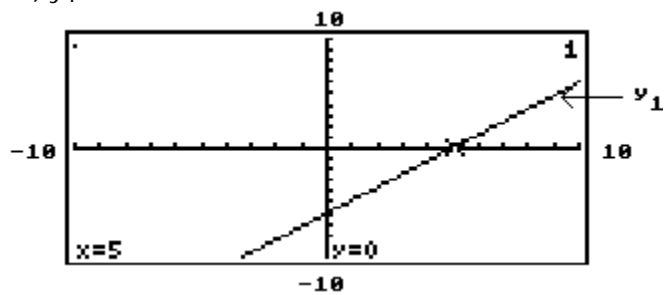

45) _____

- A) {0} B) {-5}
 C) {5} D) Cannot be determined

46) $y_1 < 0$

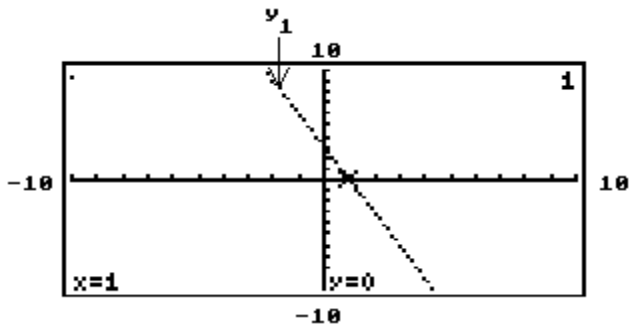

46) _____

- A) $(3, \infty)$ B) $(-\infty, 1)$
 C) $(1, \infty)$ D) Cannot be determined

47) $y_1 > 0$

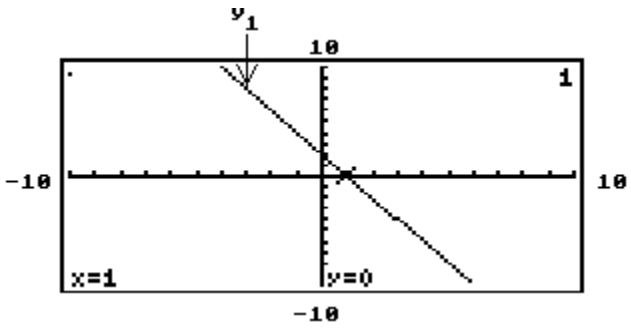

47) _____

- A) $(3, \infty)$ B) $(-\infty, 1)$
 C) $(1, \infty)$ D) Cannot be determined

48) $y_1 < 0$

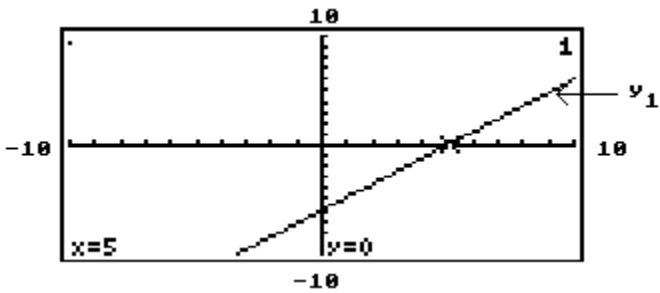

48) _____

- A) $(-5, \infty)$ B) $(-\infty, -5)$ C) $(-\infty, 5)$ D) $(5, \infty)$

49) $y_1 > 0$

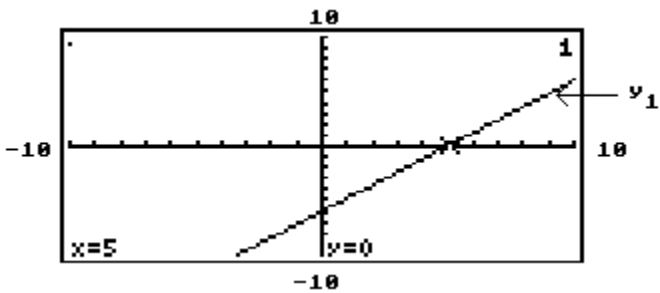

49) _____

- A) $(-5, \infty)$ B) $(-\infty, 5)$ C) $(-\infty, -5)$ D) $(5, \infty)$

50) $y_1 = 0$

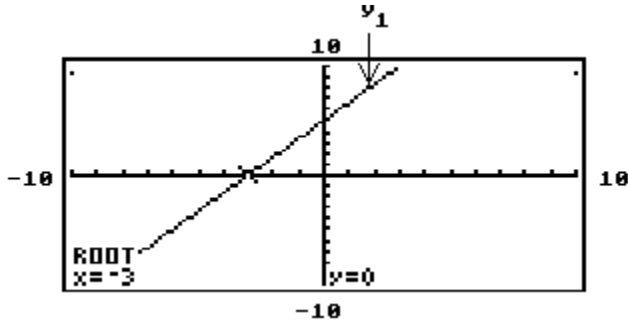

50) _____

- A) $\{0\}$ B) $\{5\}$
 C) $\{-3\}$ D) Cannot be determined

51) $y_1 < 0$

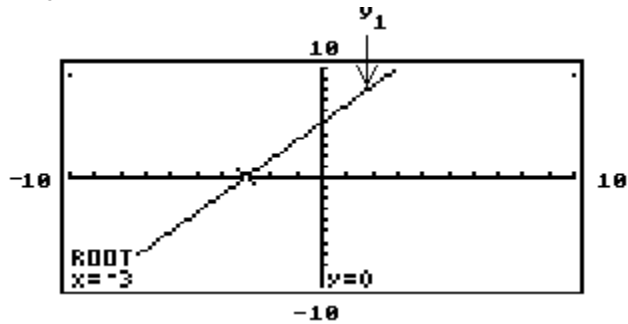

51) _____

- A) $(-\infty, -3)$ B) $(0, \infty)$ C) $(-3, \infty)$ D) $(-\infty, 0)$

52) $y_1 > 0$

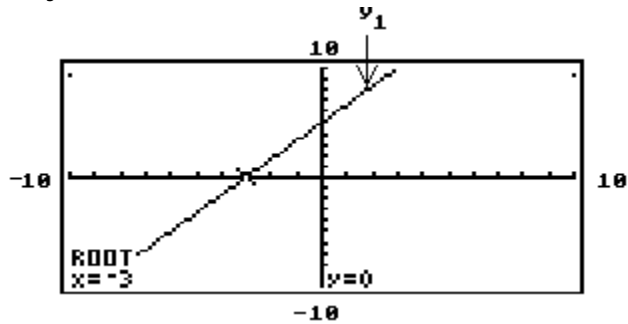

52) _____

- A) $(-3, \infty)$ B) $(-\infty, -3)$ C) $(-\infty, 0)$ D) $(0, \infty)$

SHORT ANSWER. Write the word or phrase that best completes each statement or answers the question. Provide an appropriate response.

53) In an inequality, how do you determine which side of the boundary line to shade? 53) _____

54) Is the origin a good test point in graphing an inequality of the form $Ax + By < 0$? Explain. 54) _____

55) What is the difference between the graphs of $y < mx + b$ and $y \leq mx + b$? 55) _____

56) The graph of $y > 0$ lies in which two quadrants? 56) _____

57) Name the quadrants totally or partially shaded in the graph of $y > mx + b$, when $m > 0$, $b > 0$. 57) _____

- 1) D
- 2) D
- 3) A
- 4) D
- 5) C
- 6) D
- 7) B
- 8) A
- 9) C
- 10) A
- 11) D
- 12) B
- 13) B
- 14) C
- 15) A
- 16) D
- 17) D
- 18) D
- 19) B
- 20) A
- 21) D
- 22) C
- 23) C
- 24) C
- 25) D
- 26) D
- 27) C
- 28) A
- 29) B
- 30) D
- 31) C
- 32) A
- 33) B
- 34) B
- 35) C
- 36) B
- 37) A
- 38) B
- 39) B
- 40) D
- 41) B
- 42) C
- 43) C
- 44) C
- 45) C
- 46) C
- 47) B
- 48) C
- 49) D
- 50) C
- 51) A

52) A

53) Answers may vary. One possibility: Use a test point.

54) No. The origin is not a good test point because, for all values of A and B, it lies on the boundary line. (Explanations may vary.)

55) The boundary line of $y < mx + b$ is a dashed line. The boundary line of $y \leq mx + b$ is a solid line.

56) I and II

57) I, II, and III

Exam

Name _____

MULTIPLE CHOICE. Choose the one alternative that best completes the statement or answers the question.

Decide whether the relation is a function.

1) $\{(-1, -1), (1, -4), (4, -2), (7, -6), (12, -3)\}$ 1) _____

A) Not a function B) Function

2) $\{(-4, 1), (-3, -6), (3, -8), (3, 4)\}$ 2) _____

A) Not a function B) Function

3) $\{(-8, 2), (-8, 8), (-1, 9), (4, -9), (10, -9)\}$ 3) _____

A) Not a function B) Function

4) $\{(2, -9), (2, -2), (4, 9), (9, -6), (12, -9)\}$ 4) _____

A) Not a function B) Function

5) $\{(-5, -4), (-3, -1), (1, 7), (6, -4)\}$ 5) _____

A) Function B) Not a function

6) $\{(-9, 3), (-9, 5), (1, 4), (3, 7), (10, 6)\}$ 6) _____

A) Not a function B) Function

7) $\{(-6, 2), (-3, 1), (-1, -1), (4, -9)\}$ 7) _____

A) Function B) Not a function

8) $\{(-3, 4), (-2, -2), (-1, -1), (-1, 7)\}$ 8) _____

A) Not a function B) Function

9) $\{(-5, 5), (-1, 6), (3, 6), (7, -8)\}$ 9) _____

A) Function B) Not a function

10) $\{(-2, -6), (2, 7), (6, -4), (9, 1), (11, -4)\}$ 10) _____

A) Not a function B) Function

11)

x	1	2	6	8	11
y	3	-8	-4	3	9

 11) _____

A) Function B) Not a function

12)

x	-7	-7	1	5	9
y	2	1	5	7	-8

 12) _____

A) Function B) Not a function

13)

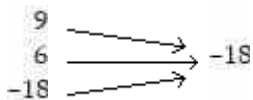

13) _____

A) Function B) Not a function

14)

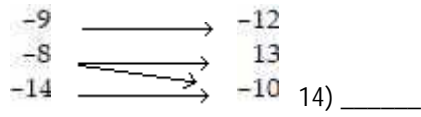

14) _____

A) Function B) Not a function

15)

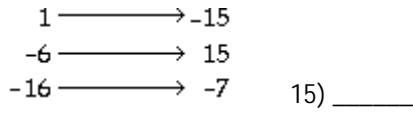

15) _____

A) Function B) Not a function

16)

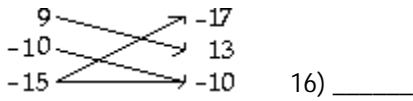

16) _____

A) Function B) Not a function

17)

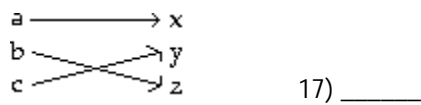

17) _____

A) Function B) Not a function

18)

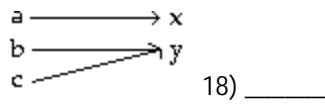

18) _____

A) Function B) Not a function

19)

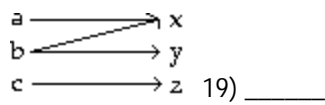

19) _____

A) Function B) Not a function

Decide whether the relation is a function, and give the domain and range.

20)

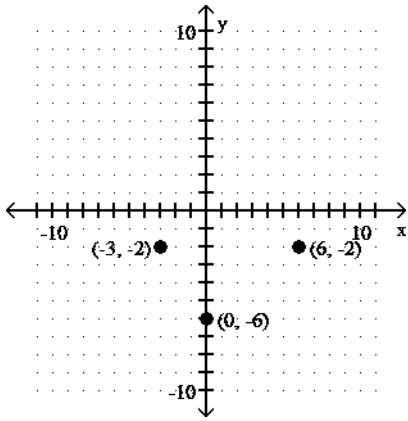

20) _____

- A) Not a function; domain: $\{-3, 0, 6\}$; range: $\{-2, -6\}$
- B) Not a function; domain: $\{-2, -6\}$; range: $\{-3, 0, 6\}$
- C) Function; domain: $\{-2, -6\}$; range: $\{-3, 0, 6\}$
- D) Function; domain: $\{-3, 0, 6\}$; range: $\{-2, -6\}$

21)

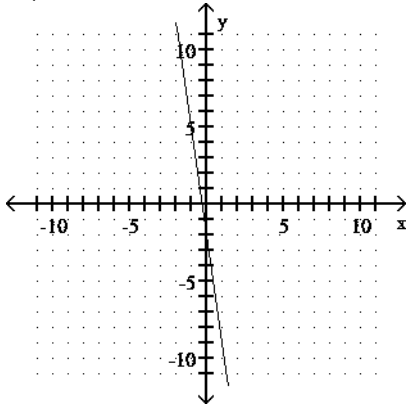

21) _____

- A) Not a function; domain: $(-\infty, \infty)$; range: $(-\infty, \infty)$
- B) Not a function; domain: $(-\infty, 0) \cup (0, \infty)$; range: $(-\infty, \infty)$
- C) Function; domain: $(-\infty, 0) \cup (0, \infty)$; range: $(-\infty, \infty)$
- D) Function; domain: $(-\infty, \infty)$; range: $(-\infty, \infty)$

22)

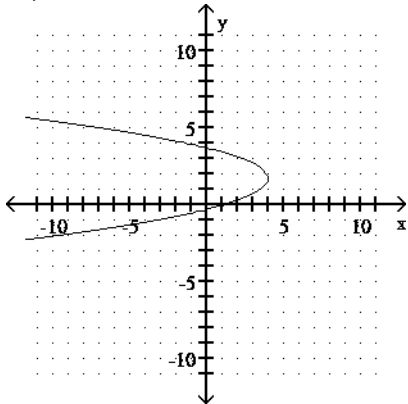

22) _____

- A) Not a function; domain: $(-\infty, 4]$; range: $(-\infty, \infty)$
- B) Not a function; domain: $(-\infty, \infty)$; range: $(-\infty, \infty)$

C) Function; domain: $(-\infty, 4]$; range: $(-\infty, \infty)$

D) Function; domain: $(-\infty, \infty)$; range: $(-\infty, \infty)$

23)

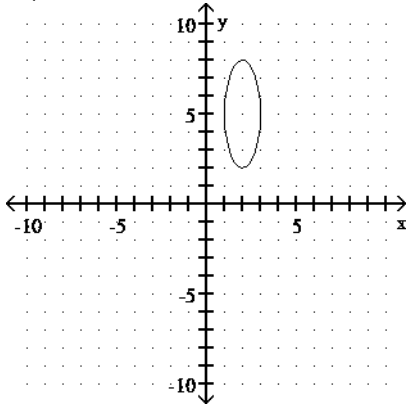

23) _____

A) Not a function; domain: $[1, 3]$; range: $[2, 8]$

B) Function; domain: $[2, 8]$; range: $[1, 3]$

C) Function; domain: $[1, 3]$; range: $[2, 8]$

D) Not a function; domain: $[2, 8]$; range: $[1, 3]$

24)

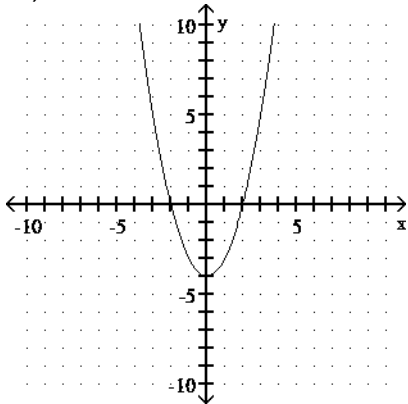

24) _____

A) Function; domain: $(-\infty, \infty)$; range: $[-4, \infty)$

B) Function; domain: $[-4, \infty)$; range: $(-\infty, \infty)$

C) Not a function; domain: $(-\infty, \infty)$; range: $[-4, \infty)$

D) Not a function; domain: $[-4, \infty)$; range: $(-\infty, \infty)$

25)

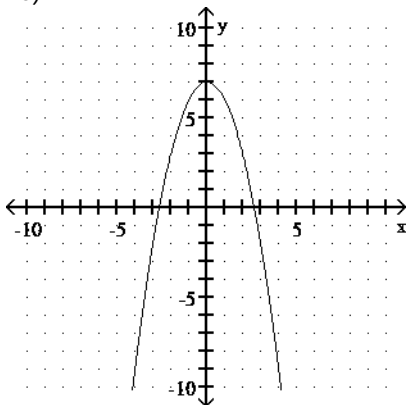

25) _____

- A) Function; domain: $(-\infty, 7]$; range: $(-\infty, \infty)$
- B) Not a function; domain: $(-\infty, \infty)$; range: $(-\infty, 7]$
- C) Function; domain: $(-\infty, \infty)$; range: $(-\infty, 7]$
- D) Not a function; domain: $(-\infty, 7]$; range: $(-\infty, \infty)$

Determine whether the relation defines y as a function of x . Give the domain.

26) $6x = 13 - 5y$ 26) _____

- A) Not a function; domain: $(-\infty, \infty)$
- B) Not a function; domain: all whole numbers
- C) Function; domain: $(-\infty, \infty)$
- D) Function; domain: all integers

27) $y = x^3$ 27) _____

- A) Function; domain: $(-\infty, \infty)$
- B) Function; domain: all whole numbers
- C) Not a function; domain: $(-\infty, \infty)$
- D) Not a function; domain: all whole numbers

28) $y^2 = 4x$ 28) _____

- A) Function; domain: $(-\infty, 0]$
- B) Function; domain: $(-\infty, \infty)$
- C) Not a function; domain: $[0, \infty)$
- D) Not a function; domain: $(-\infty, 0]$

29) $y = \sqrt{7x - 6}$ 29) _____

- A) Not a function; domain: $\left[\frac{6}{7}, \infty\right)$
- B) Not a function; domain: $\left(-\infty, \frac{6}{7}\right]$
- C) Function; domain: $(-\infty, \infty)$
- D) Function; domain: $\left[\frac{6}{7}, \infty\right)$

30) $5x + 7y < -8$ 30) _____

- A) Not a function; domain: $(-\infty, \infty)$
- B) Not a function; domain: $\left(-\frac{8}{7}, \infty\right)$
- C) Function; domain: $\left(-\infty, \frac{8}{7}\right)$
- D) Function; domain: $(-\infty, \infty)$

31) $y = -\frac{9}{x}$ 31) _____

- A) Not a function; domain $(-\infty, 0) \cup (0, \infty)$
- B) Not a function; domain $(-\infty, 9) \cup (9, \infty)$
- C) Function; domain: $(-\infty, \infty)$
- D) Function; domain $(-\infty, 0) \cup (0, \infty)$

32) $y = \frac{x + 5}{11}$ 32) _____

- A) Function; domain $(-\infty, -5) \cup (-5, \infty)$
- B) Not a function; domain: $(-\infty, \infty)$
- C) Not a function; domain $(-\infty, 11) \cup (11, \infty)$
- D) Function; domain: $(-\infty, \infty)$

33) $x = \sqrt[3]{y}$ 33) _____

- A) Function; domain: $[0, \infty)$
- B) Not a function; domain: $(-\infty, \infty)$

C) Function; domain: $(-\infty, \infty)$ D) Not a function; domain: $[0, \infty)$

34) $xy = -7$ 34) _____

A) Function; domain: $(-\infty, \infty)$ B) Not a function; domain: $(-\infty, \infty)$

C) Not a function; domain: $(-\infty, 0) \cup (0, \infty)$ D) Function; domain: $(-\infty, 0) \cup (0, \infty)$

35) $y = \frac{-9}{x + 19}$ 35) _____

A) Function; domain: $(-\infty, -19) \cup (-19, \infty)$

B) Not a function; domain: $(-\infty, -19) \cup (-19, 0)$

C) Not a function; domain: $(-\infty, \infty)$

D) Function; domain: $(-19, 19)$

SHORT ANSWER. Write the word or phrase that best completes each statement or answers the question.

Solve the problem.

36) The table shows the percentage of seniors at a certain 4-year college who believed that after graduating they would be able to find a job related to their field of study.

Year	Percentage
2000	62.6
2002	59.2
2004	56.2
2006	55.5
2008	48.9

(a) Does the table define a function?

(b) What are the domain and range?

(c) Call this function f . Give two ordered pairs that belong to f . 36) _____

Provide an appropriate response.

37) Give a definition of Domain. 37) _____

38) The equation of a circle can be written in the form $x^2 + y^2 = r^2$. Is this a function? Explain. 38) _____

39) The equation $y = x^2$ is satisfied by the points $(2, 4)$ and $(-2, 4)$. A horizontal line may be drawn between these two points. Is $y = x^2$ a function? Explain. 39) _____

- 1) B
- 2) A
- 3) A
- 4) A
- 5) A
- 6) A
- 7) A
- 8) A
- 9) A
- 10) B
- 11) A
- 12) B
- 13) A
- 14) B
- 15) A
- 16) B
- 17) A
- 18) A
- 19) B
- 20) D
- 21) D
- 22) A
- 23) A
- 24) A
- 25) C
- 26) C
- 27) A
- 28) C
- 29) D
- 30) A
- 31) D
- 32) D
- 33) D
- 34) D
- 35) A
- 36) (a) yes
(b) domain: {2000, 2002, 2004, 2006, 2008}, range: {62.6, 59.2, 56.2, 55.5, 48.9}
(c) Answers will vary. Any two of the following ordered pairs may be given:
(2000, 62.6), (2002, 59.2), (2004, 56.2), (2006, 55.5), (2008, 48.9)
- 37) The set of all values of the independent variable (x)
- 38) No. It is not a function since for all $y \neq 0$, there are two y-values for each x-value. It thus fails the vertical line test. (Explanations will vary.)
- 39) Yes. It is a function because for each x-value there is only one y-value. The relation thus passes the vertical line test. It does not have to pass the horizontal line test to be a function. (Explanations will vary.)

Exam

Name _____

MULTIPLE CHOICE. Choose the one alternative that best completes the statement or answers the question.
Solve the problem.

1) Find $f(-1)$ when $f(x) = x^2 + 3x + 6$. 1) _____
A) 10 B) -2 C) -8 D) 4

2) Find $f(0)$ when $f(x) = x^2 + 5x + 4$. 2) _____
A) 4 B) -4 C) 16 D) 9

3) Find $f(-1)$ when $f(x) = 3x^2 + 2x + 7$. 3) _____
A) 8 B) 6 C) 12 D) -6

4) Find $f\left(\frac{1}{4}\right)$ if $f(x) = 5x^2 - 7x - 8$. 4) _____

A) $-\frac{5}{8}$ B) $\frac{5}{8}$ C) $\frac{151}{16}$ D) $-\frac{151}{16}$

5) Find $f(k - 1)$ when $f(x) = 5x^2 - 3x - 3$. 5) _____
A) $5k^2 - 13k + 5$ B) $5k^2 - 13k - 1$ C) $-13k^2 + 5k + 5$ D) $5k^2 - 18k - 1$

6) Find $f(k)$ when $f(x) = 3x^2 + 4x + 5$. 6) _____
A) $3k^2 + 4k + 25$ B) $3k^2 + 4k + 5$ C) $3k^2 + 16k + 5$ D) $9k^2 + 16k + 25$

7) Find $g(a - 1)$ when $g(x) = \frac{1}{3}x - 1$. 7) _____

A) $\frac{1}{3}a - 1$ B) $\frac{a - 4}{3}$ C) $\frac{a + 4}{3}$ D) $\frac{1}{3}a - 3$

8) Find $g(a + 1)$ when $g(x) = 5x - 2$. 8) _____
A) $\frac{1}{5}a - 2$ B) $5a + 3$ C) $5a - 2$ D) $5a - 1$

Evaluate the function.

9) Find $f(5)$ if $f = \{(-2, 3), (3, 0), (0, 5), (5, -2)\}$ 9) _____
A) 0 B) -2 C) None of these D) $(-2, 0)$

10) Find $f(4)$

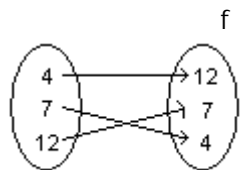

10) _____

A) None of these B) (12, 7) C) 7 D) 12

11) Find $f(2)$.

x	$y = f(x)$
2	8
1	2
0	0
-1	2
-2	8

11) _____

A) 2 B) 8 C) 1 D) 0

12) Find $f(-2)$.

x	$y = f(x)$
7	4
4	1
1	-2
-2	-5
-5	-8

12) _____

A) -2 B) 1 C) 5 D) -5

13) The graph of $y = f(x)$ is shown below. Find $f(-1)$

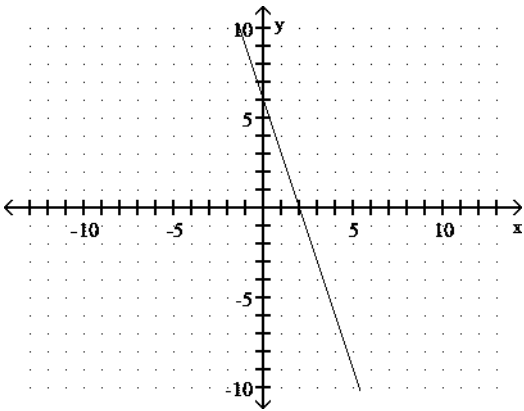

13) _____

A) 9 B) 3 C) 6 D) -3

14) The graph of $y = f(x)$ is shown below. Find $f(2)$

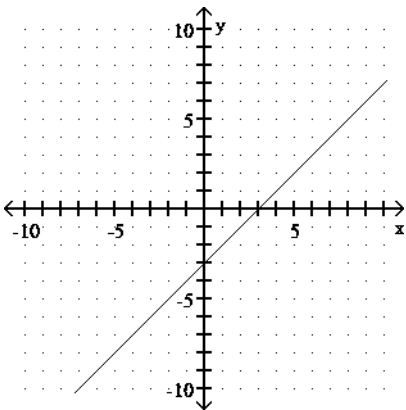

14) _____

- A) -1 B) 1 C) 2 D) -3

An equation that defines y as a function of x is given. Solve for y in terms of x , and replace y with the function notation $f(x)$.

15) $5x - 6y = 5$ 15) _____
 A) $f(x) = -5x - \frac{5}{6}$ B) $f(x) = \frac{5-5x}{-6}$ C) $f(x) = 5 - 5x$ D) $f(x) = 5 - \frac{5x}{6}$

16) $9x^2 + 7y = 6$ 16) _____
 A) $f(x) = \frac{6-9x^2}{7}$ B) $f(x) = 6 - 9x^2$ C) $f(x) = -9x^2 + \frac{6}{7}$ D) $f(x) = \frac{6+9x^2}{7}$

Graph the linear function. Give the domain and range.

17) $f(x) = -5x + 2$

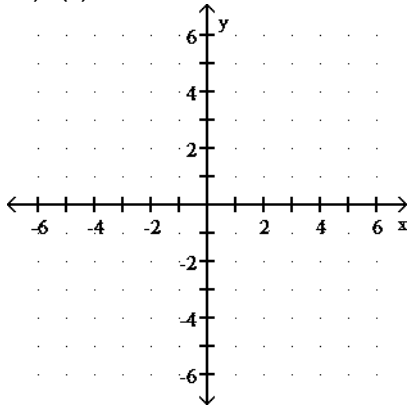

17) _____

A) Domain: $(-\infty, \infty)$

Range: $(-\infty, \infty)$

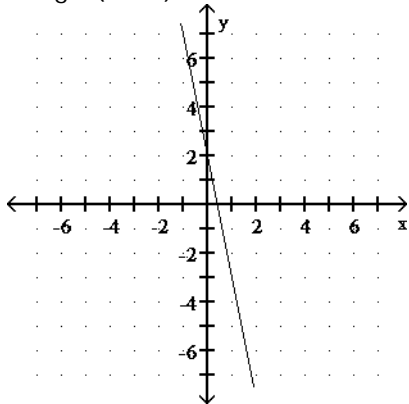

B) Domain: $(-\infty, \infty)$

Range: $(-\infty, \infty)$

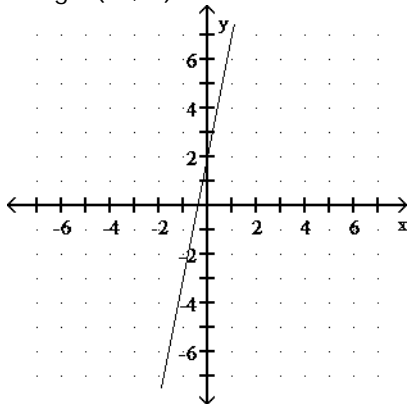

18) $g(x) = x + 5$

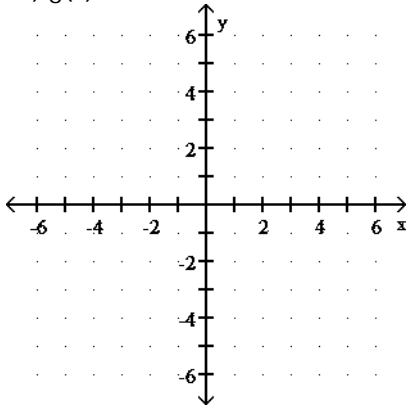

18) _____

A) Domain: $(-\infty, \infty)$

Range: $(-\infty, \infty)$

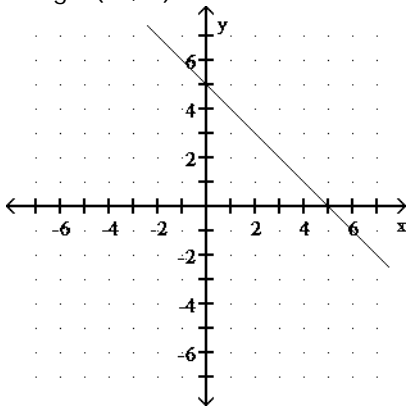

B) Domain: $(-\infty, \infty)$

Range: $(-\infty, \infty)$

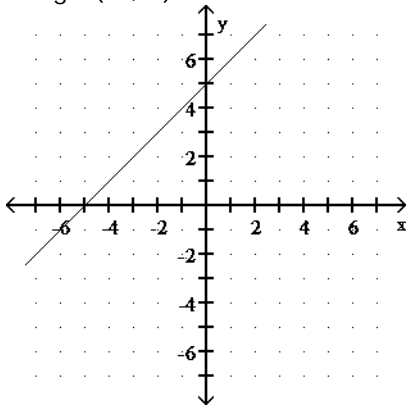

19) $h(x) = -6x$

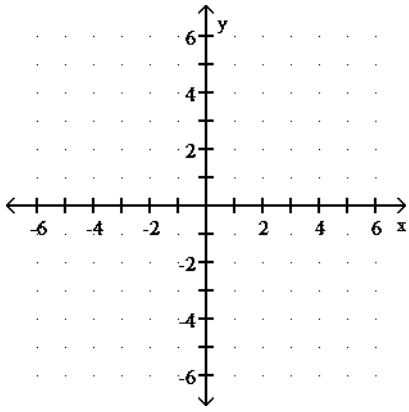

19) _____

A) Domain: $(-\infty, \infty)$

Range: $(-\infty, \infty)$

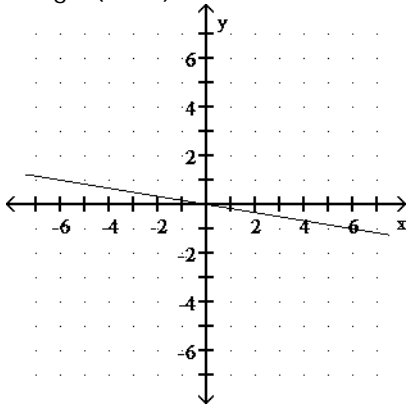

B) Domain: $(-\infty, \infty)$

Range: $(-\infty, \infty)$

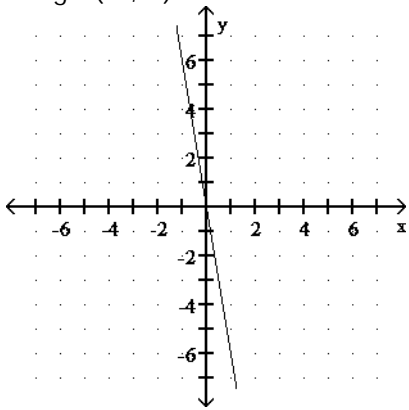

20) $f(x) = \frac{1}{2}x + 2$

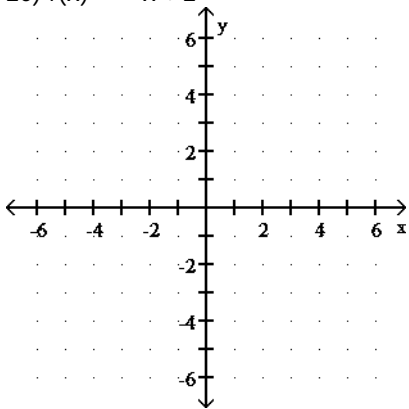

20) _____

A) Domain: $(-\infty, \infty)$

Range: $(-\infty, \infty)$

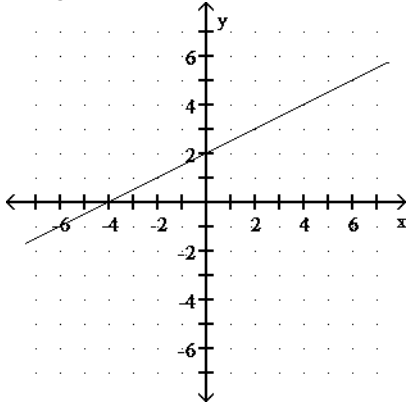

Range: $(-\infty, \infty)$

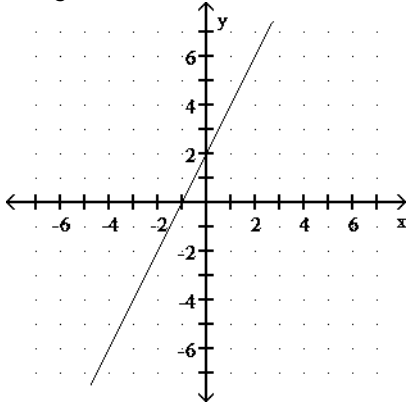

B) Domain: $(-\infty, \infty)$

21) $f(x) = \frac{1}{2}x$

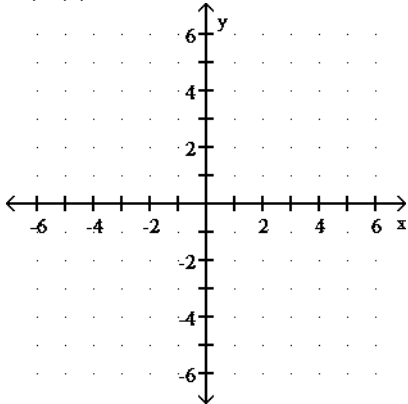

21) _____

A) Domain: $(-\infty, \infty)$

Range: $(-\infty, \infty)$

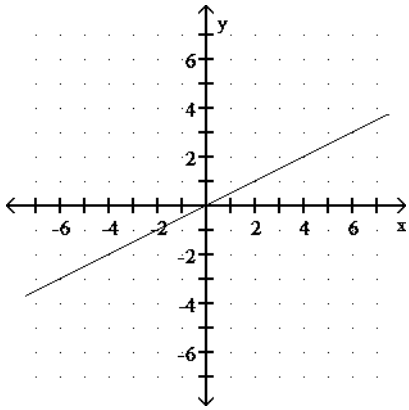

Range: $(-\infty, \infty)$

B) Domain: $(-\infty, \infty)$

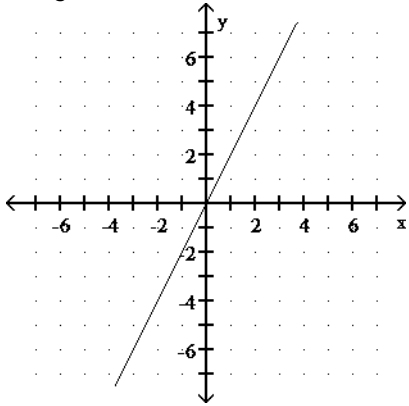

22) $h(x) = -1$

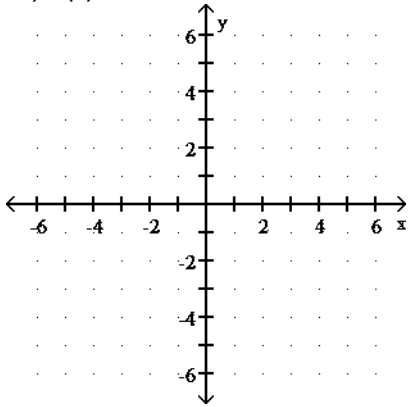

22) _____

A) Domain: $(-\infty, \infty)$

Range: $\{-1\}$

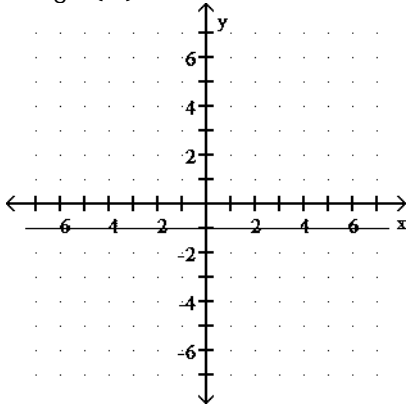

B) Domain: $\{-1\}$

Range: $(-\infty, \infty)$

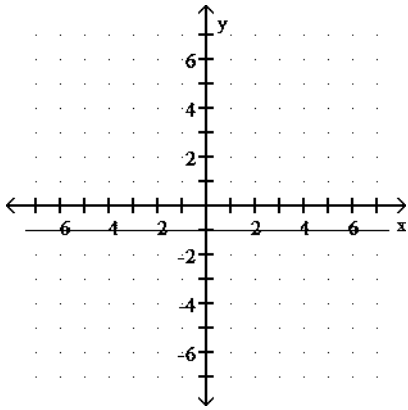

Solve the problem.

23) Crafty Bill's Cool Car Sales opened as a used car sales lot in 1991. The graph shows the number of cars sold as a function of time. Is this the graph of a function? What is the domain?

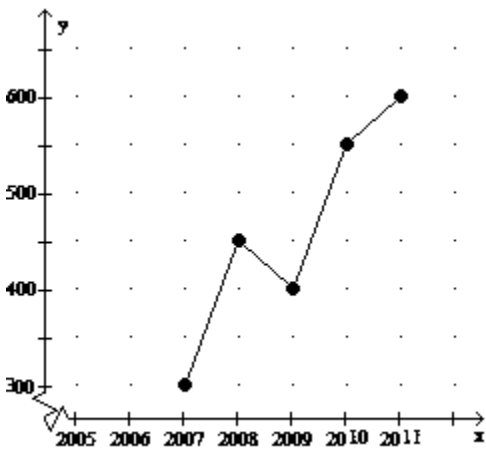

23) _____

- A) Function; Domain: [2007, 2011]
- C) Function; Domain: [2005, 2011]

- B) Not a function; Domain: [2007, 2011]
- D) Not a function; Domain: [2005, 2011]

24) Crafty Bill's Cool Car Sales opened as a used car sales lot in 2006. The graph shows the number of cars sold as a function of time. What is the approximate number of cars sold in 2008?

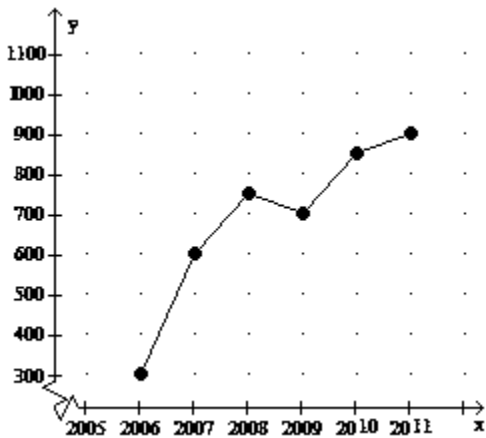

24) _____

- A) 600 cars
- B) 750 cars
- C) 150 cars
- D) 700 cars

25) Suppose all items in an ice cream truck cost \$1.00 per item. (a) Fill in the table with the correct response for the cost $f(x)$ of purchasing x items. (b). Write the linear function that gives a rule for finding the cost.

x	$f(x)$
0	
1	
2	
3	

25) _____

A) (a)

x	$f(x)$
0	\$0
1	\$1.00
2	\$1.00
3	\$1.00

 (b) $f(x) = 1.00$

B) (a)

x	$f(x)$
0	\$0
1	\$1.00
2	\$2.00
3	\$3.00

 (b) $f(x) = 1.00x$

C) (a)

x	$f(x)$
0	\$1.00
1	\$2.00
2	\$3.00
3	\$4.00

 (b) $f(x) = 1.00x + 1.00$

D) None of these

26) It has been determined that the number of fish $f(t)$ that can be caught in t minutes in a certain pond using a certain bait is $f(t) = 0.21t + 1$, for $t > 10$. Find the number of fish that can be caught if you fish for 27 minutes. Round your answer to the nearest whole number. 26) _____

- A) 14 fish B) 29 fish C) 31 fish D) 7 fish

27) Suppose the sales of a particular brand of appliance are modeled by the linear function $S(x) = 230x + 3,800$, where $S(x)$ represents the number of sales in year x , with $x = 0$ corresponding to 1982. Find the number of sales in 1998. 27) _____

- A) 7,480 sales B) 14,730 sales C) 14,960 sales D) 7,250 sales

28) Suppose $f(x) = mx + b$ is a mathematical model for actual time as a function of estimated time, where $f(x)$ represents actual time (in minutes), x represents estimated time (in minutes), and m and b are constants. If $m = 3$ and $b = -0.7$, find $f(x)$ when x is 120 minutes. 28) _____

- A) 360.7 min B) 359.3 min C) 122.1 min D) 117.9 min

29) The function H described by $H(x) = 2.75x + 71.48$ can be used to estimate the height, in centimeters, of a woman whose humerus (the bone from the elbow to the shoulder) is x cm long. Estimate the height of a woman whose humerus is 33.9 cm long. 29) _____

- A) 108.13 cm B) 40.33 cm C) 21.745 cm D) 164.705 cm

30) The mathematical model $f(x) = 700x + 30,000$ represents the cost in dollars a company has in producing x items during

a month. Based on this, how much does it cost to produce ~~800 items?~~ Interpret the question and answer using function notation. 30) _____

- A) \$560,000; $f(560,000) = 800$ B) \$590,000; $f(800) = 590,000$
 C) \$590,000; $f(590,000) = 800$ D) \$560,000; $f(800) = 560,000$

31) A truck rental company charges \$29, plus \$0.07 per mile to rent a moving truck for a day. If x represents the number of miles driven and $f(x)$ represents the total cost to rent the truck for a day, write a linear function that models the situation. 31) _____

- A) $f(x) = 0.07x + 29$ B) $f(x) = 29x + 0.07$
 C) $f(x) = 0.07x - 29$ D) $f(x) = 0.07x + 29x$

32) A truck rental company charges \$39 plus \$0.09 per mile to rent a moving truck for a day. If x represents the number of miles driven and $f(x)$ represents the total cost to rent the truck for a day, a linear function that models the situation is ~~$f(x) = 0.09x + 39$~~ . What is the cost of renting the truck if it is driven 150 miles? 32) _____

- A) \$52.50 B) \$25.50 C) \$40.35 D) \$5,850.09

33) Rental on a car is \$160 plus \$0.04 per mile. If x represents the number of miles driven and $f(x)$ represents the total cost to rent the car, a linear function that models the situation is ~~$f(x) = 0.04x + 160$~~ . Find the value of x if ~~$f(x) = 272$~~ . Interpret your answer in the context of this problem. 33) _____

- A) 171; It costs \$171 to drive the rental car 272 miles.
 B) 2,800; It costs \$2,800 to drive the rental car 272 miles.
 C) 2,800; It costs \$272 to drive the rental car 2,800 miles.
 D) 171; It costs \$272 to drive the rental car 171 miles.

34) The table represents a linear function. Find the slope and y-intercept of the line and use your answers to write an equation for $f(x)$.

x	$y = f(x)$
0	5.1
1	3.5
2	1.9
3	0.3
4	-1.3
5	-2.9

34) _____

- A) $f(x) = 5.1x - 1.6$ B) $f(x) = 1.6x + 5.1$
 C) $f(x) = -1.6x + 5.1$ D) $f(x) = -5.1x + 1.6$

Provide an appropriate response.

35) If the ordered pair (7, 6) belongs to function g , then $g(\text{---}) = \text{---}$. 35) _____
 A) $x; 6$ B) $7; 6$ C) $y; 7$ D) $6; 7$

- 1) D
- 2) A
- 3) A
- 4) D
- 5) A
- 6) B
- 7) B
- 8) B
- 9) B
- 10) D
- 11) B
- 12) D
- 13) A
- 14) A
- 15) B
- 16) A
- 17) A
- 18) B
- 19) B
- 20) A
- 21) A
- 22) A
- 23) A
- 24) B
- 25) B
- 26) D
- 27) A
- 28) B
- 29) D
- 30) B
- 31) A
- 32) A
- 33) C
- 34) C
- 35) B

Exam

Name _____

MULTIPLE CHOICE. Choose the one alternative that best completes the statement or answers the question.
Complete the table of ordered pairs for the equation.

1) $4x - 5y = -20$

x	y
-5	
-2	
3	1) _____

- A) $4; \frac{12}{5}; 0$ B) $0; \frac{12}{5}; -2$ C) $4; 0; -\frac{5}{4}$ D) $0; \frac{12}{5}; -\frac{5}{4}$

Find the x- and y-intercepts, and graph the equation.

2) $2x + 4y = 8$

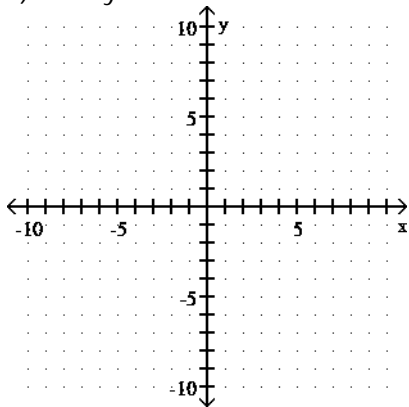

2) _____

- A) $(0, 2), (-4, 0)$

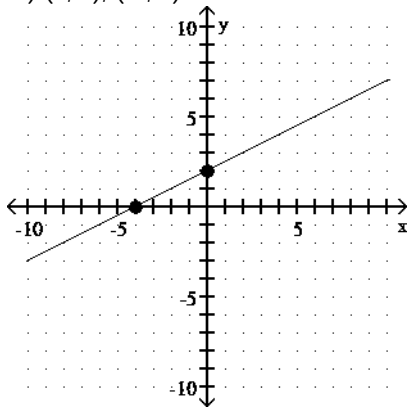

- B) $(0, -2), (4, 0)$

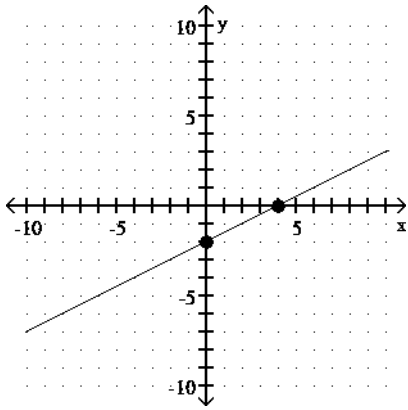

C) (0, 4), (2, 0)

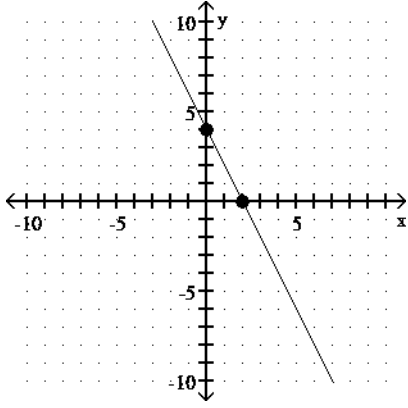

D) (0, 2), (4, 0)

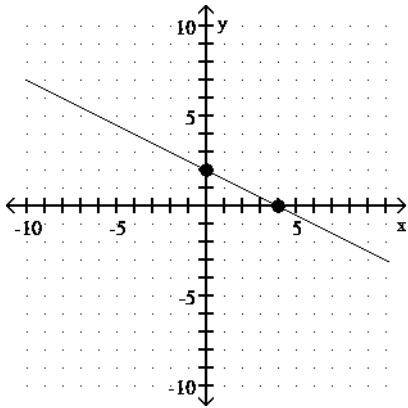

3) $y = -3$

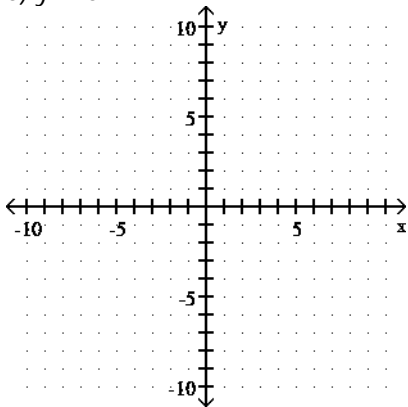

3) _____

A) (-3, 0); none

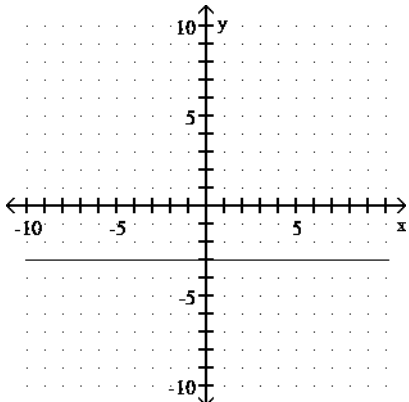

B) $(-3, 0)$; none

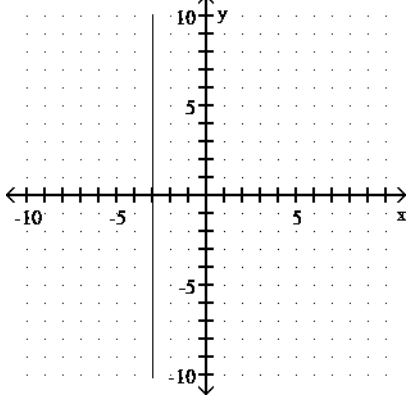

C) None; $(0, -3)$

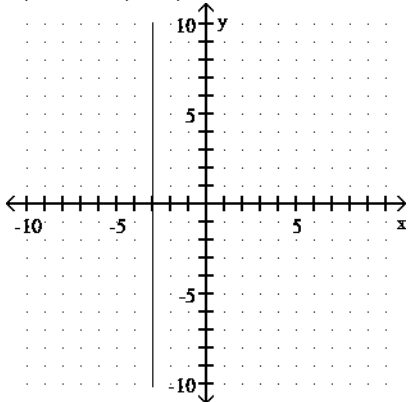

D) None; $(0, -3)$

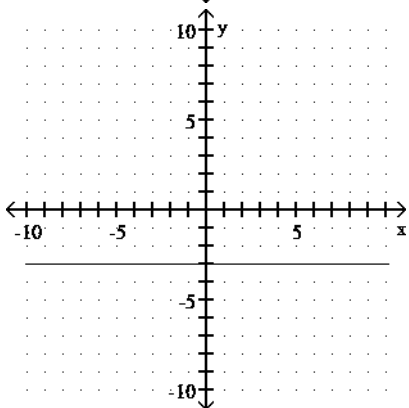

4) $x = 5$

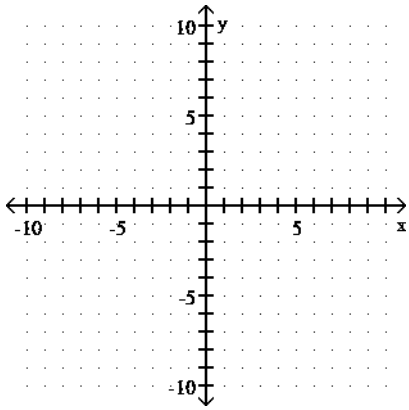

4) _____

A) (5, 0); none

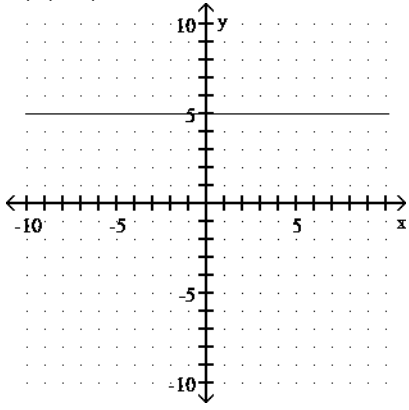

B) None; (0, 5)

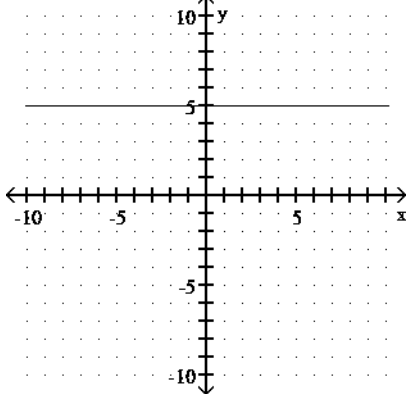

C) None; (0, 5)

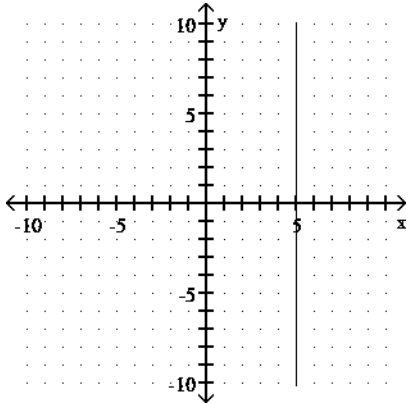

D) (5, 0); none

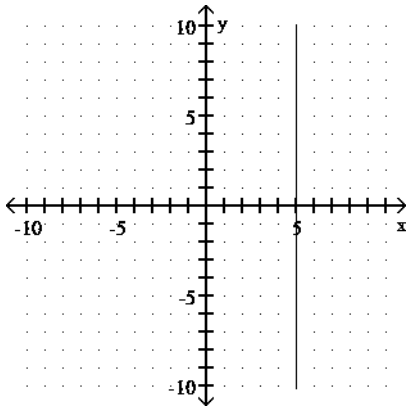

Find the slope of the line through the pair of points.

5) (5, -2) and (-7, -5) 5) _____

- A) $\frac{1}{4}$ B) -4 C) 4 D) $-\frac{1}{4}$

Answer the question.

6) How is the graph of a line with a slope equal to 0 situated in a rectangular coordinate system? 6) _____

- A) It is a horizontal line. B) It is an oblique line.
C) It is not a line. D) It is a vertical line.

Decide whether the pair of lines is parallel, perpendicular, or neither.

7) $8x + 6y = 11$ and $4y = 3x + 19$ 7) _____

- A) Parallel B) Perpendicular C) Neither

8) $4x + y = -3$ and $5y = 15x - 18$ 8) _____

- A) Parallel B) Perpendicular C) Neither

Solve the problem.

9) In 1,995, there were 117,000 farms in a state. As of 2005, there were 81,000. Find the average rate of change in the number of farms per year. 9) _____

- A) 3,600 farms per yr B) 19,800 farms per yr
C) -13,600 farms per yr D) -3,600 farms per yr

Find an equation of the line, and write it in (a) slope-intercept form if possible and (b) standard form.

10) Through (-9, 7); $m = -6$ 10) _____

- A) (a) $y = 6x - 45$
(b) $-6x + y = -45$ B) (a) $y = -6x + 54$
(b) $6x + y = 54$
C) (a) $y = -6x - 47$
(b) $6x + y = 47$ D) (a) $y = -6x - 47$
(b) $6x + y = -47$

11) Through (4, -9); horizontal 11) _____

- A) (a) $y = -9$
(b) $y = -9$ B) (a) not possible
(b) $x = 4$ C) (a) $y = -4$
(b) $y = -4$ D) (a) not possible
(b) $x = 9$

12) Through (-3, 5) and (-8, 8) 12) _____

A) (a) $y = \frac{3}{5}x + \frac{16}{5}$

(b) $-3x + 5y = 16$ B) (a) $y = -\frac{3}{5}x + \frac{16}{5}$

(b) $3x + 5y = 16$

C) (a) $y = -\frac{1}{2}x + 12$

(b) $-8x - 16y = -192$ D) (a) $y = \frac{1}{2}x + 12$

(b) $8x - 16y = -192$

13) Through (9, -2); vertical 13) _____

A) (a) not possible

(b) $x = -2$ B) (a) $y = -2$

(b) $y = -2$ C) (a) not possible

(b) $x = 9$ D) (a) $y = 9$

(b) $y = 9$

14) Through (1, 6) and parallel to $7x - 6y = 1$ 14) _____

A) (a) $y = -\frac{7}{6}x - \frac{29}{6}$

(b) $-7x - 6y = 29$ B) (a) $y = \frac{6}{7}x + \frac{6}{7}$

(b) $-6x + 7y = -6$

C) (a) $y = \frac{1}{6}x - \frac{1}{6}$

(b) $1x - 6y = 1$ D) (a) $y = \frac{7}{6}x + \frac{29}{6}$

(b) $7x - 6y = -29$

15) Through (-4, -9) and perpendicular to $y = \frac{1}{3}x + 18$ 15) _____

A) (a) $y = \frac{1}{3}x - \frac{23}{3}$

(b) $x - 3y = 23$ B) (a) $y = -\frac{1}{3}x - \frac{31}{3}$

(b) $x + 3y = -31$

C) (a) $y = 3x - 21$

(b) $3x - y = -21$ D) (a) $y = -3x - 21$

(b) $3x + y = -21$

Provide an appropriate response.

16) Which one of the following has positive slope and negative y-coordinate for its y-intercept? 16) _____

A)

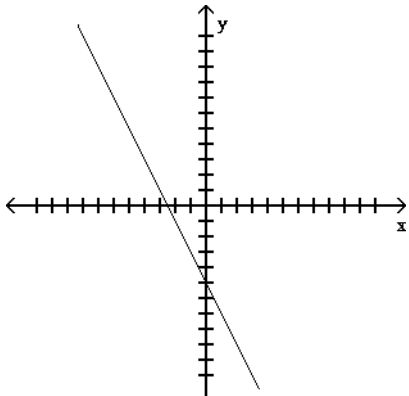

B)

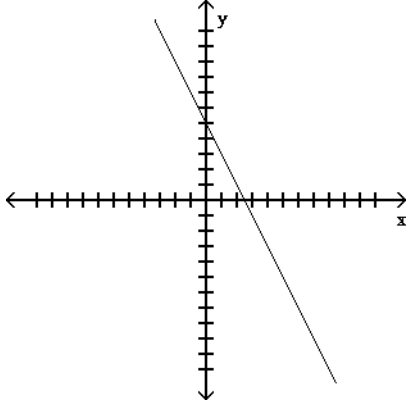

C)

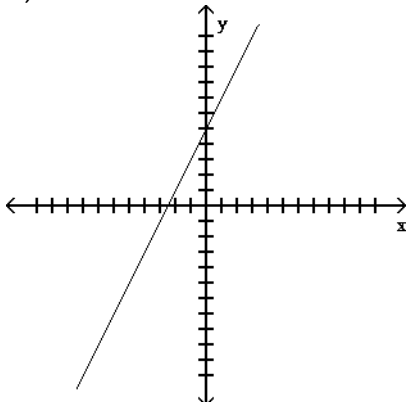

D)

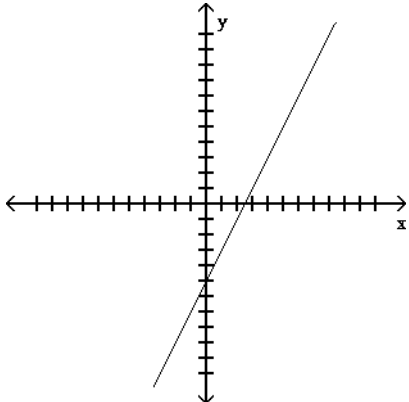

Solve the problem.

17) The information in the chart gives the salary of a person for the stated years. Use the information for the years 2001 and 2003 to find an equation that models the data. Let $x = 1$ represent 2001, $x = 3$ represent 2003, and y represent the salary. Write the equation in slope-intercept form. Use this equation to approximate the salary for 2004 to the nearest dollar.

Year	Salary
2000	\$23,500
2001	\$24,300
2002	\$25,200
2003	\$26,300
2004	\$27,200

17) _____

- A) $y = 1,000x$; \$4,000 B) $y = 1,000x + 23,500$; \$27,500
 C) $y = -1,243x + 23,500$; \$18,528 D) $y = 28.3x + 23,500$; \$23,613.2

Graph the inequality or compound inequality.

18) $2x + 7y > -1$

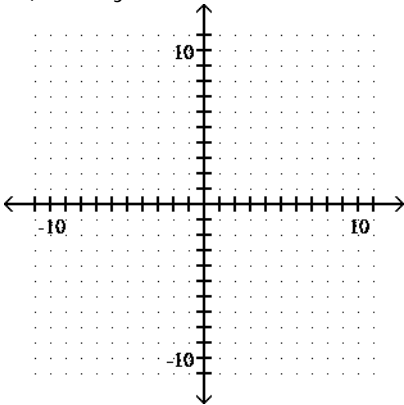

18) _____

A)

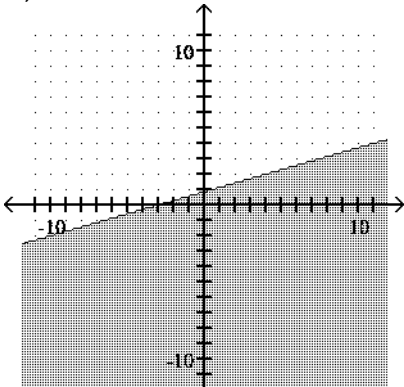

B)

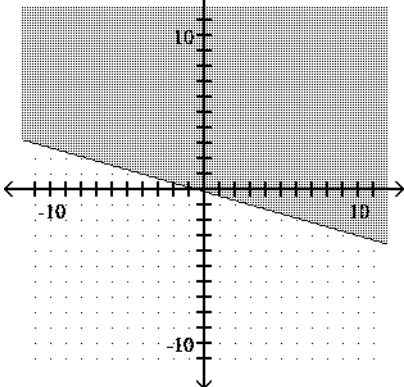

C)

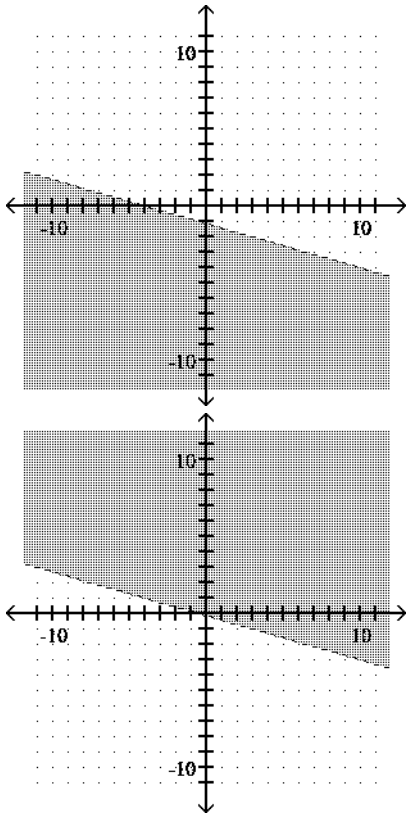

D)

19) $y \geq -3x + 1$ and $x - y \geq 1$

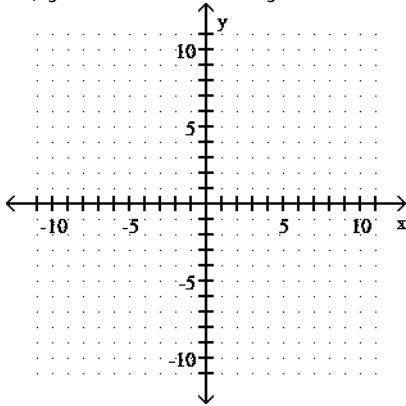

19) _____

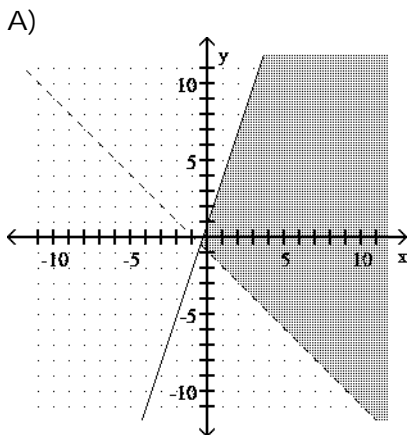

B)

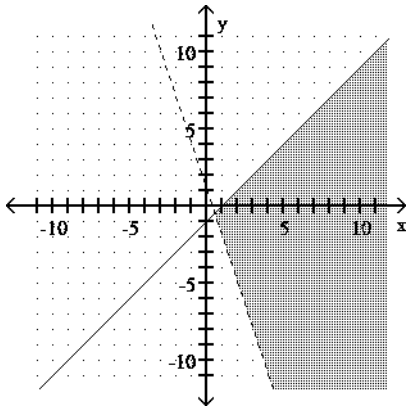

C)

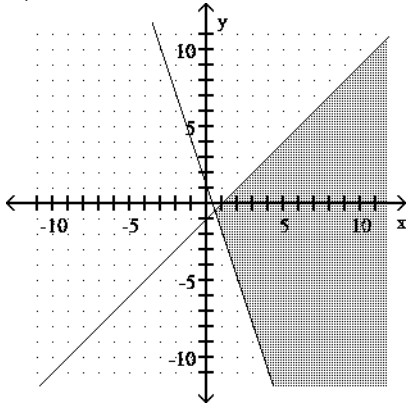

D)

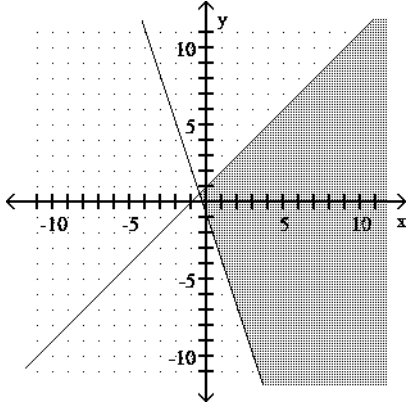

Provide an appropriate response.

20) Which one of the following is the graph of a function?

20) _____

A)

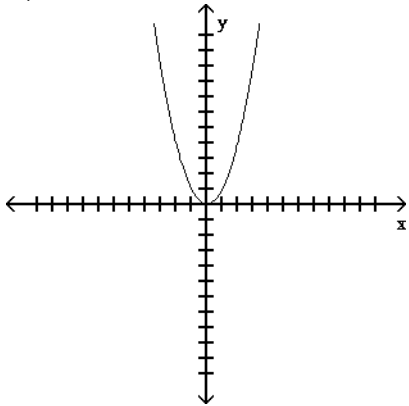

B)

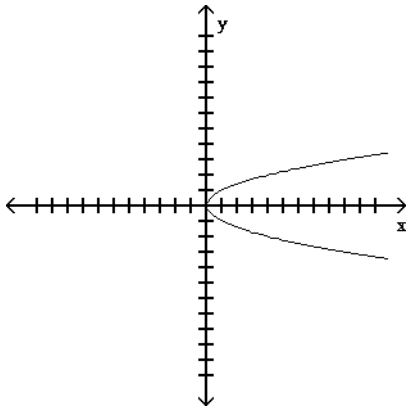

C)

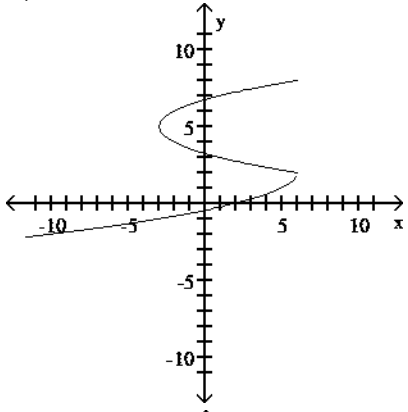

D)

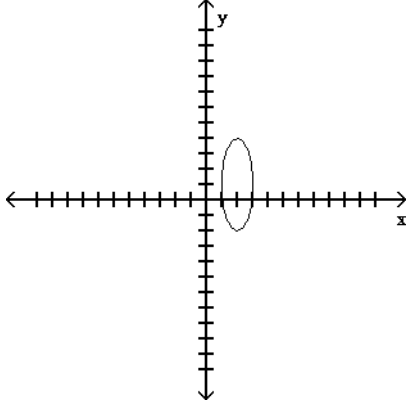

21) Which one of the following does not define y as a function of x ?

21) _____

A)

x	y
-2	-5
1	-6
-2	-6
4	-9

B) $y = \sqrt{x + 4}$

C) $y = 4x - 2$

D) $\{(1, -6), (4, -9), (9, -7)\}$

Give the domain and range of the relation shown in the following.

22)

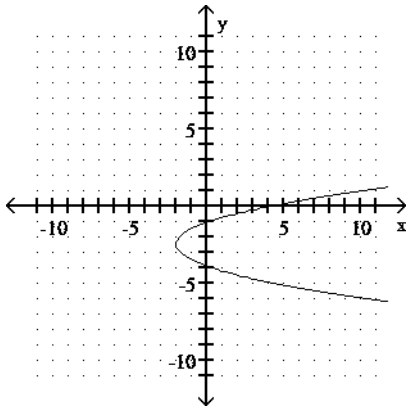

22) _____

- A) Domain: $(-2, \infty)$; range: $(-\infty, \infty)$ B) Domain: $[-2, \infty)$; range: $(-\infty, \infty)$
 C) Domain: $(-\infty, \infty)$; range: $(-\infty, -2]$ D) Domain: $(-\infty, -2]$; range: $(-\infty, \infty)$

23) $\{(4, 4), (-6, 5), (7, 10)\}$ 23) _____

- A) Domain: $\{4, -6, 7\}$; range: $\{4, 5, 10\}$ B) Domain: $\{4, -6, 7\}$; range: $\{10\}$
 C) Domain: $\{4, 5, 10\}$; range: $\{4, -6, 7\}$ D) Domain: $\{4, 7\}$; range: $\{4, 10\}$

Solve the problem.

24) Find $f(4)$ when $f(x) = -x^2 + 5x + 5$. 24) _____

- A) 9 B) 41 C) 31 D) 1

25) Find $f(a)$ when $f(x) = -x^2 - 4x - 5$. 25) _____

- A) $-a^2 - 4a - 5$ B) $a^2 - 4a - 5$ C) $-a^2 - 4a$ D) $-4a$

Graph the linear function. What is its domain and range?

26) $f(x) = \frac{5}{2}x - 3$

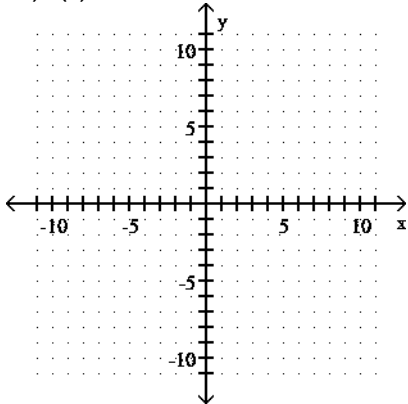

26) _____

- A) Domain: $(-\infty, \infty)$; range: $(-\infty, \infty)$

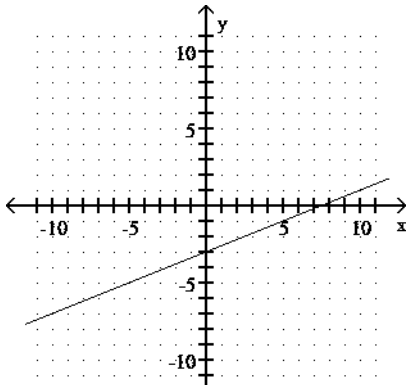

B) Domain: $(-\infty, \infty)$; range: $(-\infty, \infty)$

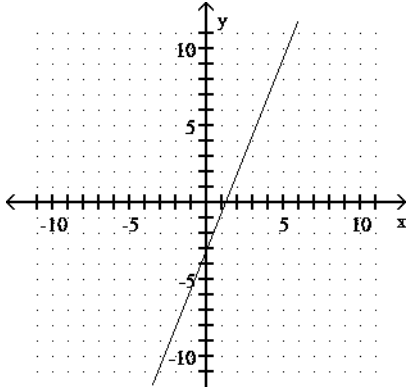

C) Domain: $(-\infty, \infty)$; range: $(-\infty, \infty)$

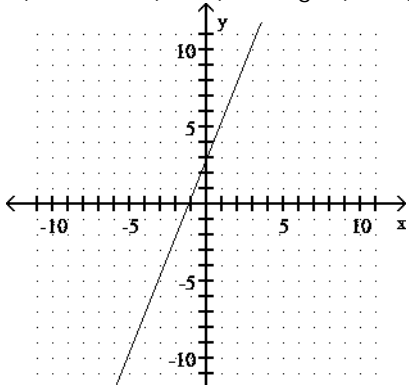

D) Domain: $(-\infty, \infty)$; range: $(-\infty, \infty)$

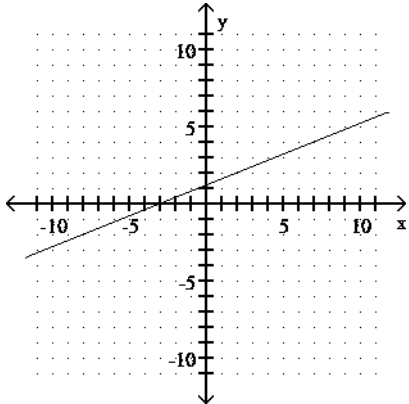

- 1) D
- 2) D
- 3) D
- 4) D
- 5) A
- 6) A
- 7) B
- 8) C
- 9) D
- 10) D
- 11) A
- 12) B
- 13) C
- 14) D
- 15) D
- 16) D
- 17) B
- 18) D
- 19) C
- 20) A
- 21) A
- 22) B
- 23) A
- 24) A
- 25) A
- 26) B