

Name \_\_\_\_\_

**MULTIPLE CHOICE. Choose the one alternative that best completes the statement or answers the question.**

Determine the intervals on which the function is increasing, decreasing, and constant.

1)

1) \_\_\_\_\_

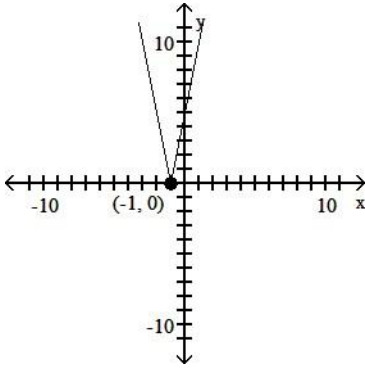

- A) Increasing on  $(1, \infty)$ ; Decreasing on  $(-\infty, 1)$   
 B) Increasing on  $(-1, \infty)$ ; Decreasing on  $(-\infty, -1)$   
 C) Increasing on  $(-\infty, 1)$ ; Decreasing on  $(1, \infty)$   
 D) Increasing on  $(-\infty, -1)$ ; Decreasing on  $(-1, \infty)$

2)

2) \_\_\_\_\_

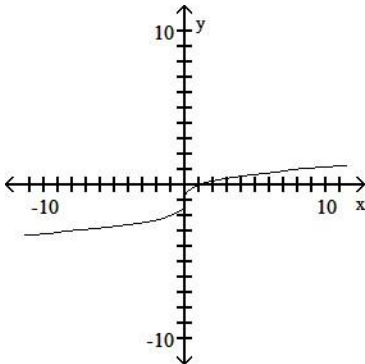

- A) Increasing on  $(0, \infty)$ ; Decreasing on  $(-\infty, 0)$   
 B) Increasing on  $(-\infty, 0)$ ; Decreasing on  $(0, \infty)$   
 C) Decreasing on  $(-\infty, \infty)$   
 D) Increasing on  $(-\infty, \infty)$

3)

3) \_\_\_\_\_

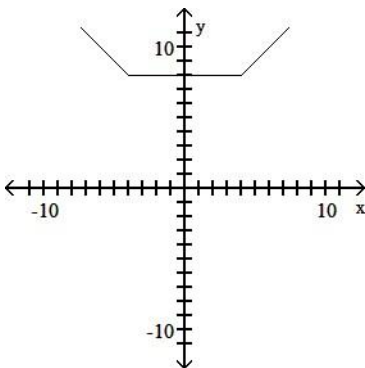

- A) Increasing on  $(-\infty, -4)$ ; Decreasing on  $(-4, \infty)$ ; Constant on  $(4, \infty)$

- B) Increasing on  $(-\infty, 4)$ ; Decreasing on  $(-\infty, -4)$ ; Constant on  $(4, \infty)$
- C) Increasing on  $(4, \infty)$ ; Decreasing on  $(-4, \infty)$ ; Constant on  $(-4, 4)$
- D) Increasing on  $(4, \infty)$ ; Decreasing on  $(-\infty, -4)$ ; Constant on  $(-4, 4)$

4)

4) \_\_\_\_\_

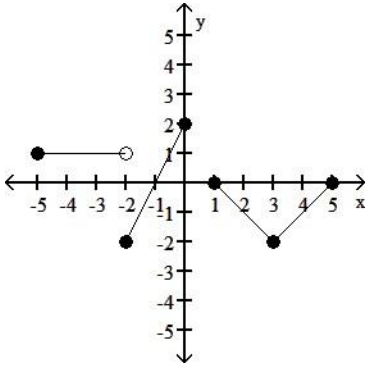

- A) Increasing on  $(1, 3)$ ; Decreasing on  $(-2, 0)$  and  $(3, 5)$ ; Constant on  $(2, 5)$
- B) Increasing on  $(-1, 0)$  and  $(3, 5)$ ; Decreasing on  $(0, 3)$ ; Constant on  $(-5, -3)$
- C) Increasing on  $(-2, 0)$  and  $(3, 4)$ ; Decreasing on  $(-5, -2)$  and  $(1, 3)$
- D) Increasing on  $(-2, 0)$  and  $(3, 5)$ ; Decreasing on  $(1, 3)$ ; Constant on  $(-5, -2)$

5)

5) \_\_\_\_\_

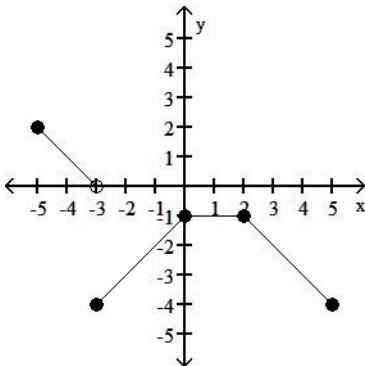

- A) Increasing on  $(-5, -3)$  and  $(2, 5)$ ; Decreasing on  $(-3, 0)$ ; Constant on  $(0, 2)$
- B) Increasing on  $(-3, -1)$ ; Decreasing on  $(-5, -2)$  and  $(2, 4)$ ; Constant on  $(-1, 2)$
- C) Increasing on  $(-3, 1)$ ; Decreasing on  $(-5, -3)$  and  $(0, 5)$ ; Constant on  $(1, 2)$
- D) Increasing on  $(-3, 0)$ ; Decreasing on  $(-5, -3)$  and  $(2, 5)$ ; Constant on  $(0, 2)$

**Determine the domain and range of the function.**

6)

6) \_\_\_\_\_

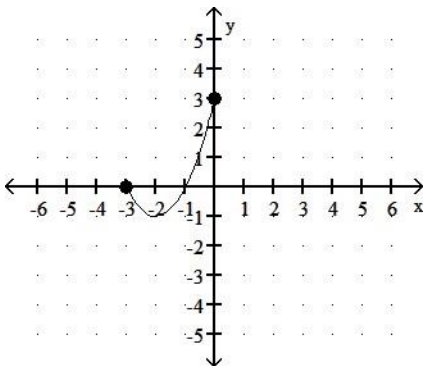

- A) domain:  $[-1, 3]$ ; range:  $[-3, 0]$
- B) domain:  $[0, 3]$ ; range:  $(-\infty, 3]$
- C) domain:  $(-\infty, 3]$ ; range:  $[0, 3]$
- D) domain:  $[-3, 0]$ ; range:  $[-1, 3]$

7)

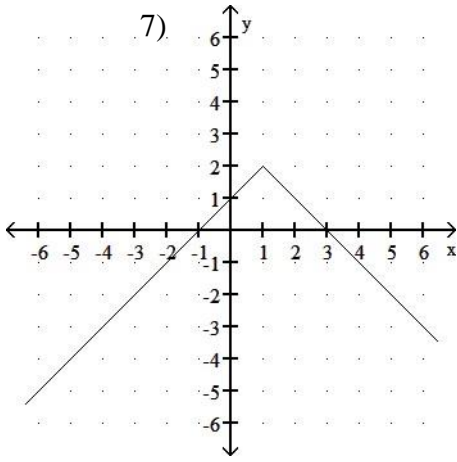

—  
—  
—

- A) domain:  $(-\infty, \infty)$ ; range:  $(-\infty, 2]$
- B) domain:  $(-\infty, 1]$ ; range:  $(-\infty, 2]$
- C) domain:  $(-\infty, \infty)$ ; range:  $(-\infty, \infty)$
- D) domain:  $(-\infty, 1) \cup (1, \infty)$ ; range:  $(-\infty, 2) \cup (2, \infty)$

8)

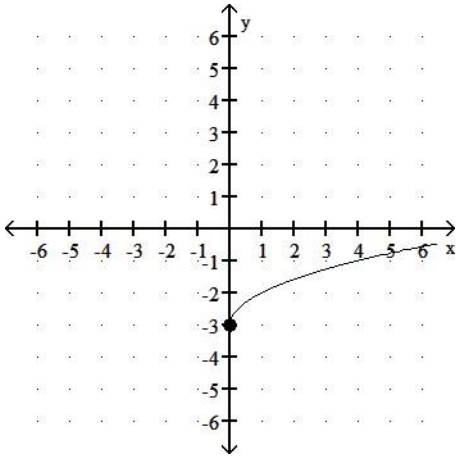

8) \_\_\_\_\_

- A) domain:  $(-\infty, \infty)$ ; range:  $[-3, \infty)$
- B) domain:  $[0, \infty)$ ; range:  $(-\infty, \infty)$
- C) domain:  $[0, \infty)$ ; range:  $[-3, \infty)$
- D) domain:  $[0, \infty)$ ; range:  $[0, \infty)$

9)

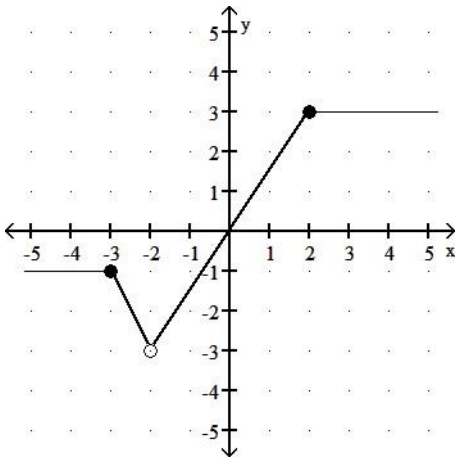

9) \_\_\_\_\_

- A) domain:  $(-\infty, \infty)$ ; range:  $[-3, 3]$
- B) domain:  $(-3, 3]$ ; range:  $(-\infty, \infty)$
- C) domain:  $(-\infty, \infty)$ ; range:  $(-3, 3]$
- D) domain:  $(-\infty, \infty)$ ; range:  $[-3, 3]$

10)

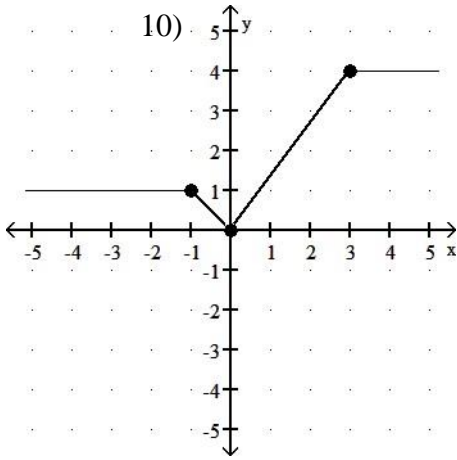

- A) domain:  $(-\infty, \infty)$ ; range:  $[0, 4]$   
 C) domain:  $(0, 4)$ ; range:  $(-\infty, \infty)$

- B) domain:  $(-\infty, \infty)$ ; range:  $(0, 4)$   
 D) domain:  $[0, 4]$ ; range:  $(-\infty, \infty)$

11)

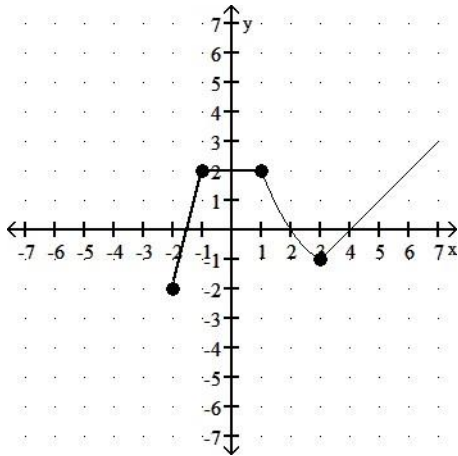

- A) domain:  $[-2, \infty)$ ; range:  $[-2, \infty)$   
 C) domain:  $(-2, \infty)$ ; range:  $(-2, \infty)$

- B) domain:  $[-2, \infty)$ ; range:  $[-2, 2]$   
 D) domain:  $[-2, 2]$ ; range:  $[-2, \infty)$

12)

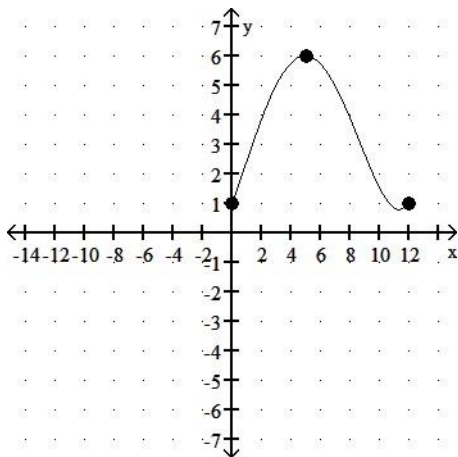

- A) domain:  $(0, 12)$ ; range:  $(1, 6)$   
 C) domain:  $[0, 12]$ ; range:  $[1, 6]$

- B) domain:  $(1, 6)$ ; range:  $(0, 12)$   
 D) domain:  $[1, 6]$ ; range:  $[0, 12]$

Using the graph, determine any relative maxima and relative minima of the function.

13)

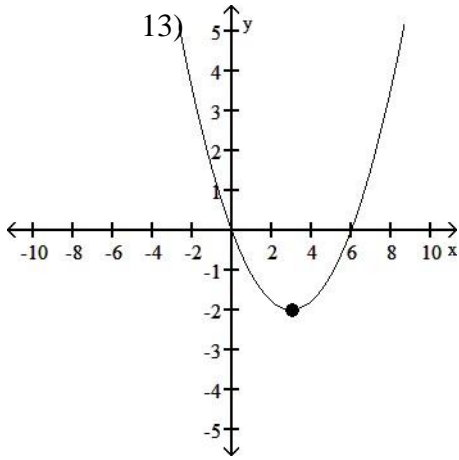

- A) Relative maximum: 3 at  $y = -2$ .  
 C) Relative minimum: -2 at  $x = 3$ .

- B) Relative maximum: -2 at  $x = 3$ .  
 D) Relative minimum: 3 at  $y = -2$ .

14)  $f(x) = x^3 - 3x^2 + 1$

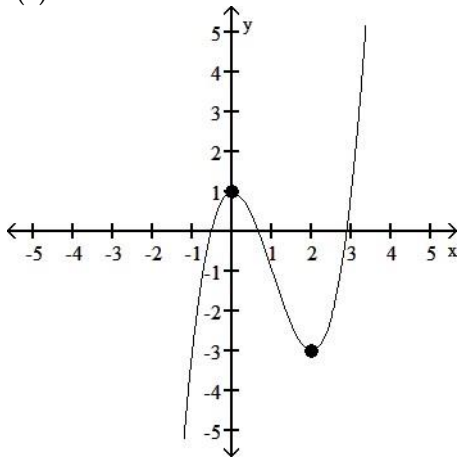

- A) Relative maximum: 1 at  $x = 0$ ; Relative minimum: none  
 B) Relative maximum: none; Relative minimum: -3 at  $x = 2$   
 C) Relative maximum: -3 at  $x = 2$ ; Relative minimum: 1 at  $x = 0$   
 D) Relative maximum: 1 at  $x = 0$ ; Relative minimum: -3 at  $x = 2$

15)  $f(x) = x^3 - 12x + 2$

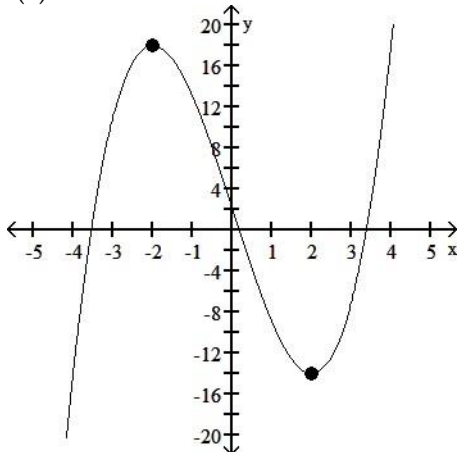

- A) Relative maximum: 18 at  $x = -2$  and 0 at  $x = 0$ ; Relative minimum: -14 at  $x = 2$

—  
—

14) \_\_\_\_\_

15) \_\_\_\_\_

- B) Relative maximum: -14 at  $x = 2$ ; Relative minimum: 18 at  $x = -2$
- C) Relative minimum: -14 at  $x = 2$ ; Relative maximum: 18 at  $x = -2$
- D) No relative maxima or minima

Graph the function. Use the graph to find any relative maxima or minima.

16)  $f(x) = x^2 - 3$

16) \_\_\_\_\_

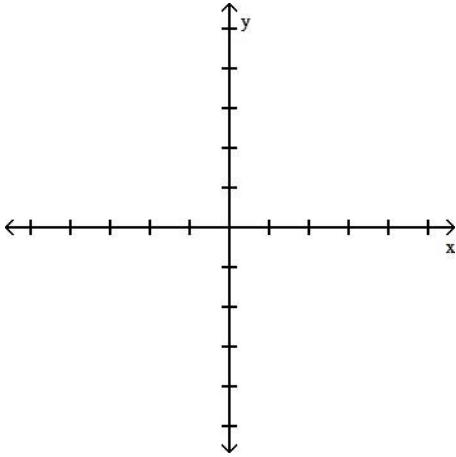

- A) Relative maximum of -3 at  $x = 0$
- C) No relative extrema

- B) Relative minimum of -3 at  $x = 1$
- D) Relative minimum of -3 at  $x = 0$

17)  $f(x) = -x^2 + 4$

17) \_\_\_\_\_

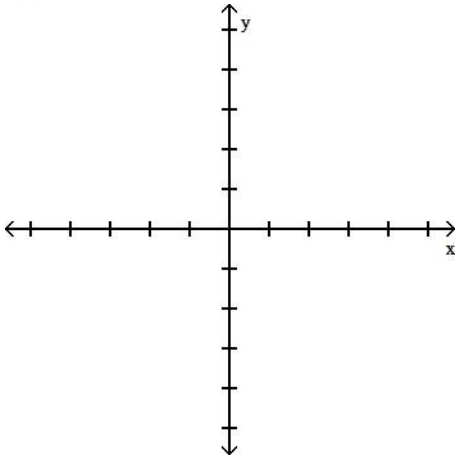

- A) No relative extrema
- B) Relative maximum of 4 at  $x = 0$  and relative minimum at  $x = 3$
- C) Relative maximum of 4 at  $x = 0$
- D) Relative minimum of 4 at  $x = 0$

18)  $f(x) = -x^2 + 8x - 15$

18)

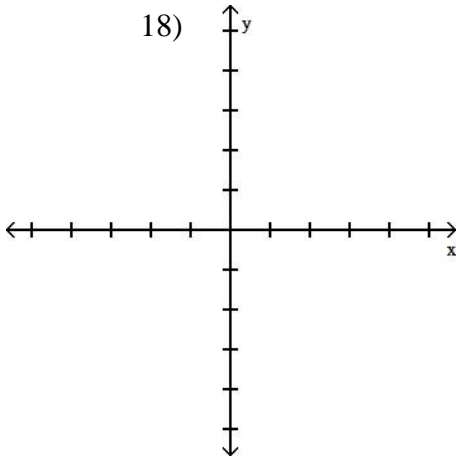

—  
—

- A) Relative minimum of 1 at  $x = 4$
- C) Relative maximum of 4 at  $x = 1$

- B) No relative extrema
- D) Relative maximum of 1 at  $x = 4$

19)  $f(x) = x^2 + 8x + 13$

19) \_\_\_\_\_

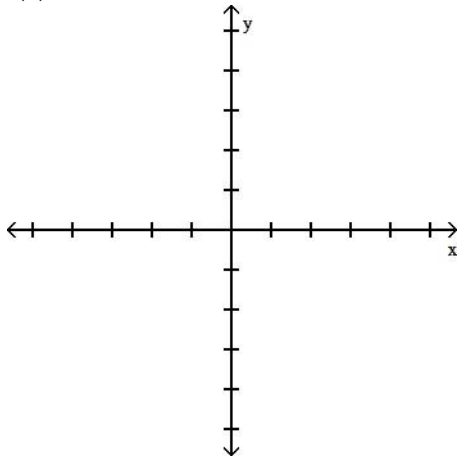

- A) Relative minimum of -3.2 at  $x = -4.1$
- C) Relative minimum of -3 at  $x = -4$

- B) Relative maximum of -3.2 at  $x = -4.1$
- D) Relative maximum of -3 at  $x = -4$

20)  $f(x) = 4 - |x|$

20) \_\_\_\_\_

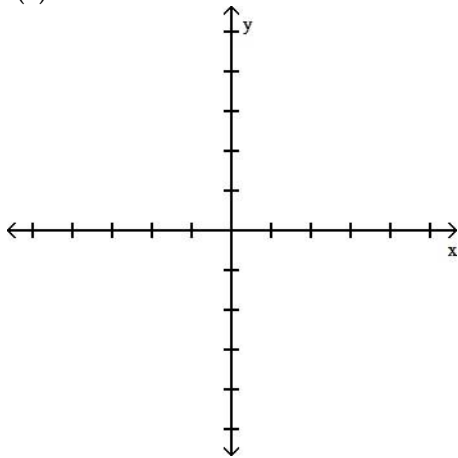

- A) No relative extrema
- C) Relative maximum of 4 at  $x = 0$

- B) Relative maximum of 4.5 at  $x = 0$
- D) Relative minimum of 4 at  $x = 0$

21)  $f(x) = |x + 1| - 3$

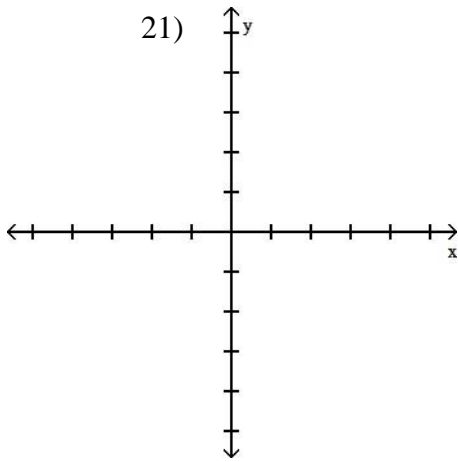

- A) Relative maximum of 3 at  $x = -1$                       B) Relative minimum of 3.2 at  $x = -1$   
 C) Relative minimum of -3 at  $x = -1$                       D) Relative minimum of 2.7 at  $x = -1$

**Solve.**

22) Elissa wants to set up a rectangular dog run in her backyard. She has 32 feet of fencing to work with and wants to use it all. If the dog run is to be  $x$  feet long, express the area of the dog run as a function of  $x$ . 22) \_\_\_\_\_

- A)  $A(x) = 18x^2 - x$     B)  $A(x) = 15x - x^2$   
 C)  $A(x) = 17x - x^2$     D)  $A(x) = 16x - x^2$

23) Bob wants to fence in a rectangular garden in his yard. He has 86 feet of fencing to work with and wants to use it all. If the garden is to be  $x$  feet wide, express the area of the garden as a function of  $x$ . 23) \_\_\_\_\_

- A)  $A(x) = 45x^2 - x$     B)  $A(x) = 42x - x^2$   
 C)  $A(x) = 43x - x^2$     D)  $A(x) = 44x - x^2$

24) A rocket is shot straight up in the air from the ground at a rate of 70 feet per second. The rocket is tracked by a rangefinder that is 473 feet from the launch pad. Let  $d$  represent the distance from the rocket to the rangefinder and  $t$  represent the time, in seconds, since "blastoff". Express  $d$  as a function of  $t$ . 24) \_\_\_\_\_

- A)  $d(t) = \sqrt{473^2 + (70t)^2}$     B)  $d(t) = \sqrt{70^2 + (473t)^2}$   
 C)  $d(t) = 473 + 70t^2$     D)  $d(t) = 473^2 + (70t)^2$

25) Sue wants to put a rectangular garden on her property using 76 meters of fencing. There is a river that runs through her property so she decides to increase the size of the garden by using the river as one side of the rectangle. (Fencing is then needed only on the other three sides.) Let  $x$  represent the length of the side of the rectangle along the river. Express the garden's area as a function of  $x$ . 25) \_\_\_\_\_

- A)  $A(x) = 37x - \frac{1}{4}x^2$     B)  $A(x) = 38x^2 - x$   
 C)  $A(x) = 39x - 2x^2$     D)  $A(x) = 38x - \frac{1}{2}x^2$

26) A farmer's silo is the shape of a cylinder with a hemisphere as the roof. If the height of the silo is 113 feet and the radius of the hemisphere is  $r$  feet, express the volume of the silo as a function of  $r$ . 26) \_\_\_\_\_

- A)  $V(r) = \frac{1}{2}\pi r^3 + \pi r^2(113 - r)$



$$r) = 113\pi r^2 + \frac{8}{3} \pi r^3$$

B)  $V(r) = \pi(113 - r)r^2 + \frac{4}{3} \pi r^3$

C)  $V(r) = \pi(113 - r) + \frac{4}{3} \pi r^2$

D)  $V(r) = \pi(113 - r)r^2 + \frac{2}{3} \pi r^3$

27) A farmer's silo is the shape of a cylinder with a hemisphere as the roof. If the radius of the hemisphere is 10 feet and the height of the silo is  $h$  feet, express the volume of the silo as a function of  $h$ . 27) \_\_\_\_\_

A)  $V(h) = 100 \pi(h - 10) + \frac{2000}{3} \pi$

B)  $V(h) = 4100 \pi(h - 10) + \frac{500}{7} \pi$

C)  $V(h) = 100 \pi h + \frac{4000}{3} \pi h^2$

D)  $V(h) = 100 \pi(h^2 - 10) + \frac{5000}{3} \pi$

28) A rectangular sign is being designed so that the length of its base, in feet, is 4 feet less than 4 times the height,  $h$ . Express the area of the sign as a function of  $h$ . 28) \_\_\_\_\_

A)  $A(h) = -4h^2 + 2h$

B)  $A(h) = -4h + h^2$

C)  $A(h) = -4h + 4h^2$

D)  $A(h) = 4h - 2h^2$

29) From a 16-inch by 16-inch piece of metal, squares are cut out of the four corners so that the sides can then be folded up to make a box. Let  $x$  represent the length of the sides of the squares, in inches, that are cut out. Express the volume of the box as a function of  $x$ . 29) \_\_\_\_\_

A)  $V(x) = 2x^3 - 48x^2 + 16x$

B)  $V(x) = 4x^3 - 64x^2$

C)  $V(x) = 4x^3 - 64x^2 + 256x$

D)  $V(x) = 2x^3 - 48x^2$

30) A rectangular box with volume 374 cubic feet is built with a square base and top. The cost is \$1.50 per square foot for the top and the bottom and \$2.00 per square foot for the sides. Let  $x$  represent the length of a side of the base. Express the cost the box as a function of  $x$ . 30) \_\_\_\_\_

A)  $C(x) = 4x + \frac{2992}{x^2}$

B)  $C(x) = 2x^2 + \frac{2992}{x}$

C)  $C(x) = 3x^2 + \frac{2992}{x}$

D)  $C(x) = 3x^2 + \frac{1496}{x}$

31) A rectangle that is  $x$  feet wide is inscribed in a circle of radius 26 feet. Express the area of the rectangle as a function of  $x$ . 31) \_\_\_\_\_

A)  $A(x) = x(2704 - x^2)$

B)  $A(x) = x\sqrt{2704 - x^2}$

C)  $A(x) = x\sqrt{2028 - x}$

D)  $A(x) = x^2\sqrt{1352 - x^2}$

32) From a 15-inch by 15-inch piece of metal, squares are cut out of the four corners so that the sides can then be folded up to make a box. Let  $x$  represent the length of the sides of the squares, in inches, that are cut out. 32) \_\_\_\_\_

out. 32)

Express the volume of the box as a function of  $x$ . Graph the function and from the graph determine the value of  $x$ , to the nearest tenth of an inch, that will yield the maximum volume.

- A) 2.3 inches                      B) 2.8 inches                      C) 2.5 inches                      D) 3.1 inches

33) From a 24-inch by 24-inch piece of metal, squares are cut out of the four corners so that the sides can then be folded up to make a box. Let  $x$  represent the length of the sides of the squares, in inches, that are cut out. Express the volume of the box as a function of  $x$ . Graph the function and from the graph determine the value of  $x$ , to the nearest tenth of an inch, that will yield the maximum volume. 33) \_\_\_\_\_

- A) 3.7 inches                      B) 3.8 inches                      C) 4.1 inches                      D) 4.0 inches

34) A rectangular box with volume 468 cubic feet is built with a square base and top. The cost is \$1.50 per square foot for the top and the bottom and \$2.00 per square foot for the sides. Let  $x$  represent the length of a side of the base in feet. Express the cost of the box as a function of  $x$  and then graph this function. From the graph find the value of  $x$ , to the nearest hundredth of a foot, which will minimize the cost of the box. 34) \_\_\_\_\_

- A) 8.55 feet                      B) 8.44 feet                      C) 7.92 feet                      D) 8.63 feet

35) A rectangular box with volume 517 cubic feet is built with a square base and top. The cost is \$1.50 per square foot for the top and the bottom and \$2.00 per square foot for the sides. Let  $x$  represent the length of a side of the base in feet. Express the cost of the box as a function of  $x$  and then graph this function. From the graph find the value of  $x$ , to the nearest hundredth of a foot, which will minimize the cost of the box. 35) \_\_\_\_\_

- A) 8.79 feet                      B) 8.49 feet                      C) 8.91 feet                      D) 8.83 feet

36) A rectangle that is  $x$  feet wide is inscribed in a circle of radius 20 feet. Express the area of the rectangle as a function of  $x$ . Graph the function and from the graph determine the value of  $x$ , to the nearest tenth of a foot, which will maximize the area of the rectangle. 36) \_\_\_\_\_

- A) 27.9 feet                      B) 29.1 feet                      C) 28.3 feet                      D) 28.7 feet

37) A rectangle that is  $x$  feet wide is inscribed in a circle of radius 32 feet. Express the area of the rectangle as a function of  $x$ . Graph the function and from the graph determine the value of  $x$ , to the nearest tenth of a foot, which will maximize the area of the rectangle. 37) \_\_\_\_\_

A) 44.9 feet

B) 45.7 feet

C) 45.3 feet

D) 44.5 feet

38) Elissa sells two breeds of dogs, Alaskan Malamutes and Great Pyrenees. She has 112 feet of fencing to enclose two adjacent rectangular dog kennels, one for each breed. An existing fence is to form one side of the kennels, as in the drawing below. Suppose the total length of the two kennels is  $x$  feet. Express the total area of the two kennels as a function of  $x$ . Graph the function and from the graph determine the value of  $x$  that will yield the maximum area.

38) \_\_\_\_\_

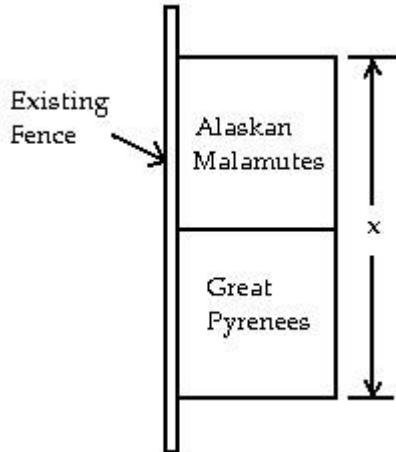

A) 55 feet

B)  $56\frac{1}{2}$  feet

C) 58 feet

D) 56 feet

39) Elissa sells two breeds of dogs, Alaskan Malamutes and Great Pyrenees. She has 62 feet of fencing to enclose two adjacent rectangular dog kennels, one for each breed. An existing fence is to form one side of the kennels, as in the drawing below. Let  $x$  represent the measurement indicated. Express the total area of the two kennels as a function of  $x$ . Graph the function and from the graph determine the value of  $x$ , rounded to the hundredths place, that will yield the maximum area.

39) \_\_\_\_\_

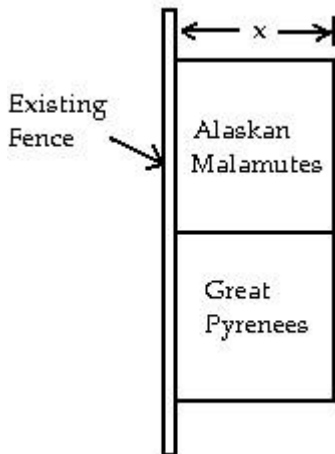

A) 10.50 feet

B) 10.33 feet

C) 10.67 feet

D) 15.50 feet

For the piecewise function, find the specified function value.

40)  $f(x) = \begin{cases} 7x, & \text{for } x \leq -1, \\ x - 7, & \text{for } x > -1 \end{cases}$

40) \_\_\_\_\_

$f(-1)$

A) -7

B) -6

C) -8

D) 7

41)

$f(x) =$

$$\begin{cases} x - 8, & \text{for } x < 5, \\ 4 - x, & \text{for } x \geq 5 \end{cases}$$

f(0)

A) -1

B) -3

C) 4

D) -8

—  
—

42)  $f(x) = \begin{cases} 3x + 6, & \text{for } x \leq 0, \\ 6 - 3x, & \text{for } 0 < x < 3, \\ x, & \text{for } x \geq 3 \end{cases}$

f(4)

A) 18

B) -6

C) 3

D) 4

42) —

43)  $f(x) = \begin{cases} 9x + 1, & \text{for } x < 1, \\ 3x, & \text{for } 3 \leq x \leq 7, \\ 3 - 6x, & \text{for } x > 7 \end{cases}$

f(3)

A) 43

B) 9

C) -15

D) 10

43) —

44)  $f(x) = \begin{cases} 7x + 1, & \text{for } x < 6, \\ 6x, & \text{for } 6 \leq x \leq 10, \\ 6 - 3x, & \text{for } x > 10 \end{cases}$

f(-6)

A) 43

B) -36

C) -41

D) 24

44) —

Graph the function.

45)  $f(x) = \begin{cases} -4, & \text{for } x \geq 1, \\ -2 - x, & \text{for } x < 1 \end{cases}$

45) —

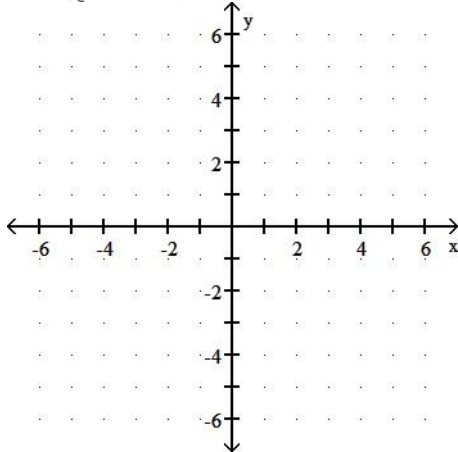

A)

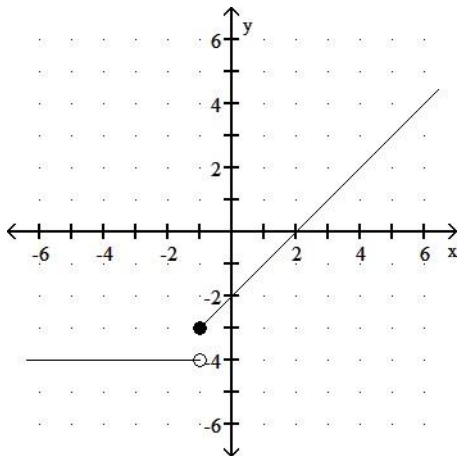

C)

B)

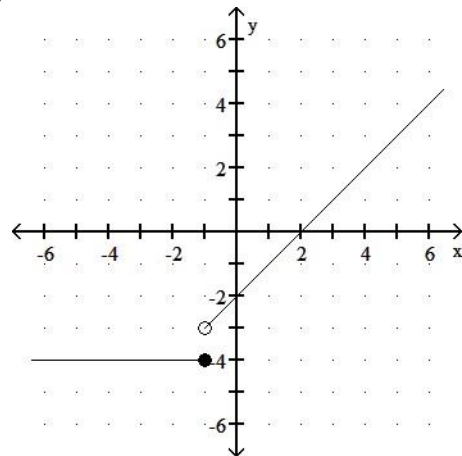

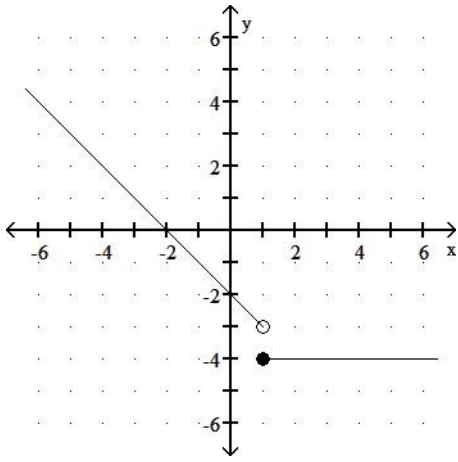

D)

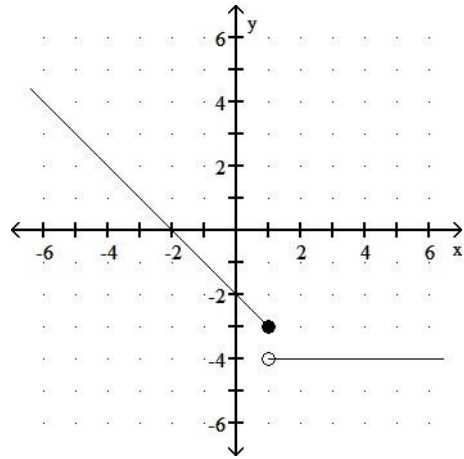

$$46) f(x) = \begin{cases} x - 4, & \text{for } x > 0, \\ -5, & \text{for } x \leq 0 \end{cases}$$

46) \_\_\_\_\_

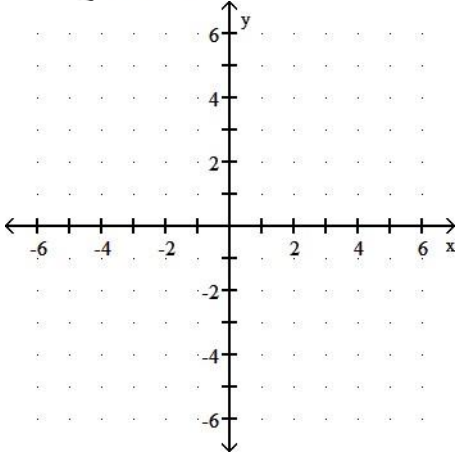

A)

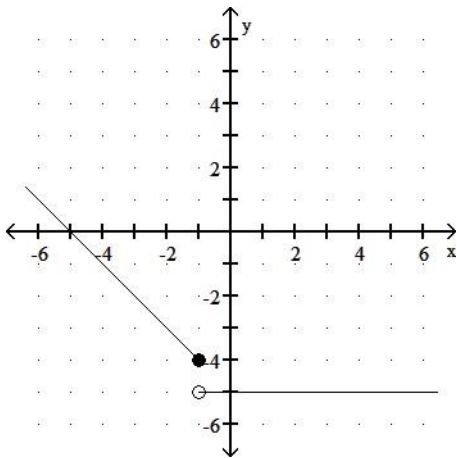

B)

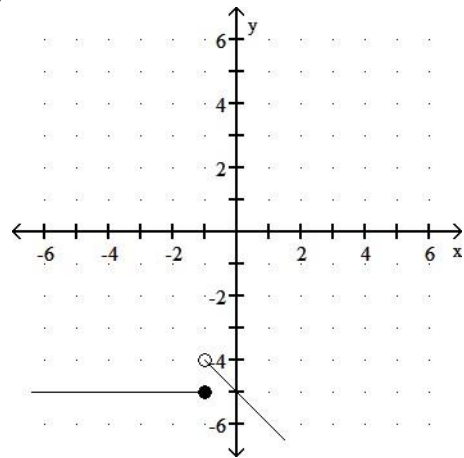

C)

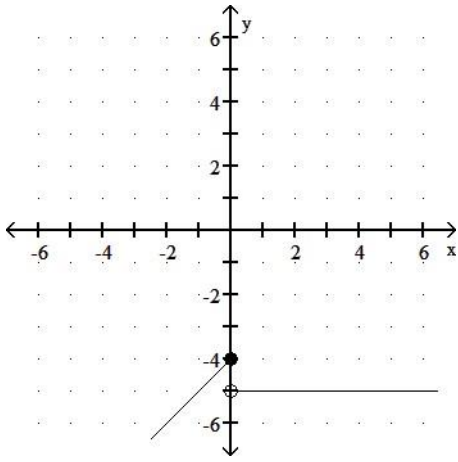

D)

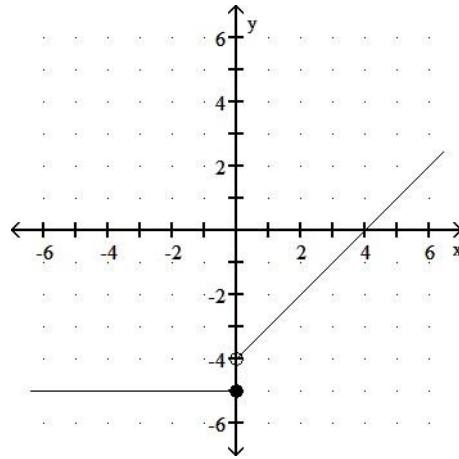

$$47) f(x) = \begin{cases} 4 - x, & \text{for } x \leq 2, \\ 1 - 2x, & \text{for } x > 2 \end{cases}$$

47) \_\_\_\_\_

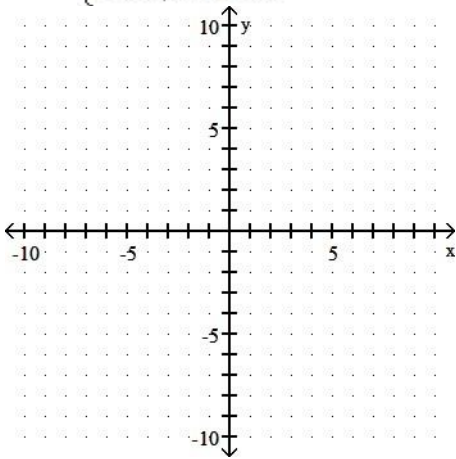

A)

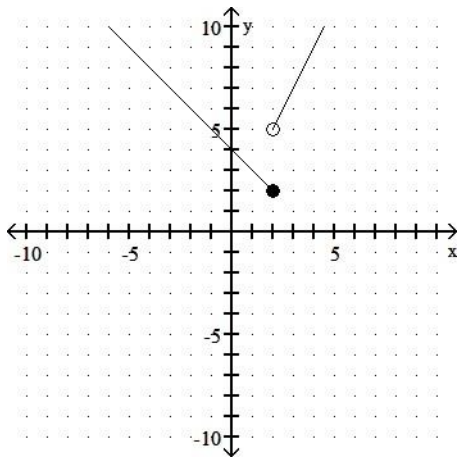

B)

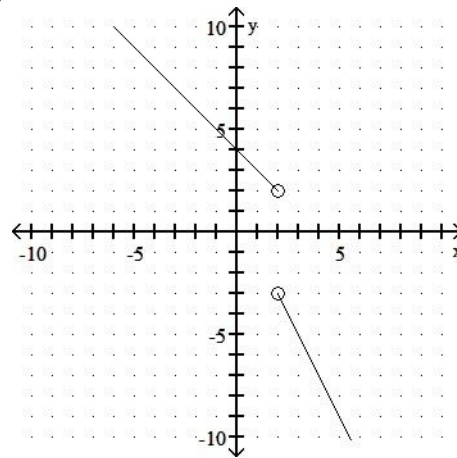

C)

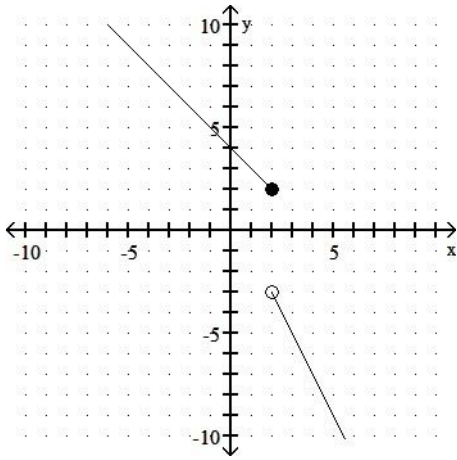

D)

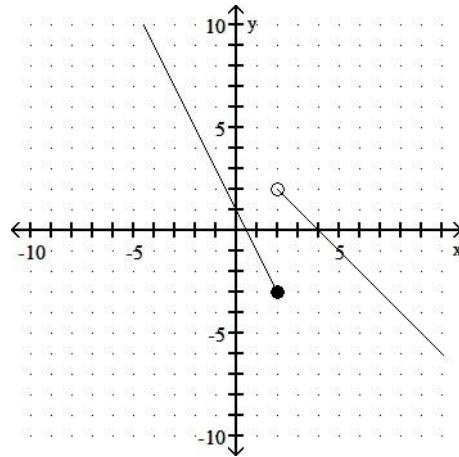

48) 
$$f(x) = \begin{cases} \frac{1}{x+1} & \text{for } x \neq -1, \\ 3, & \text{for } x = -1 \end{cases}$$

48) \_\_\_\_\_

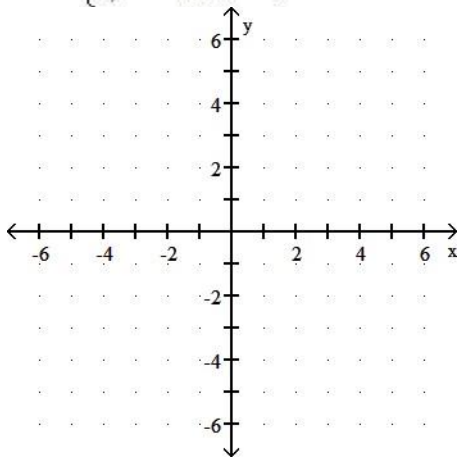

A)

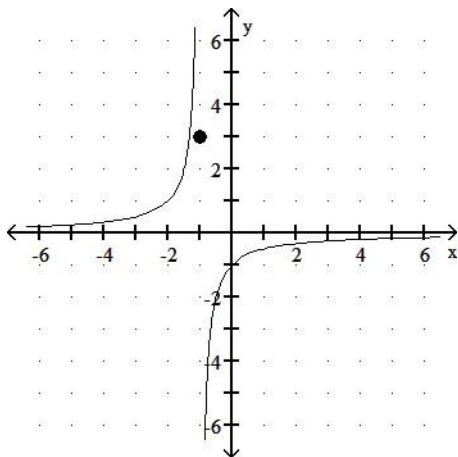

B)

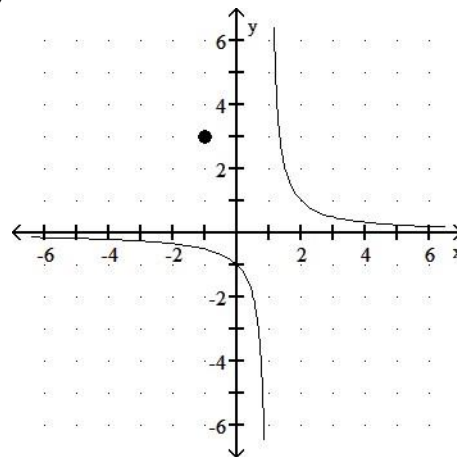

C)

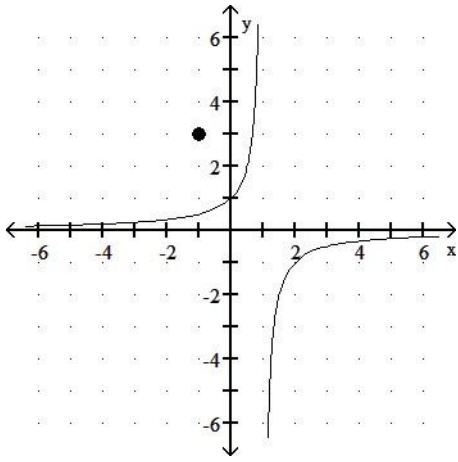

D)

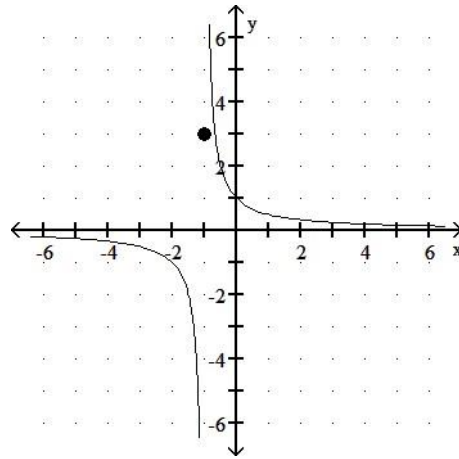

49) 
$$f(x) = \begin{cases} \frac{x^2 - 4}{x + 2}, & \text{for } x \neq -2, \\ 5, & \text{for } x = -2 \end{cases}$$

49) \_\_\_\_\_

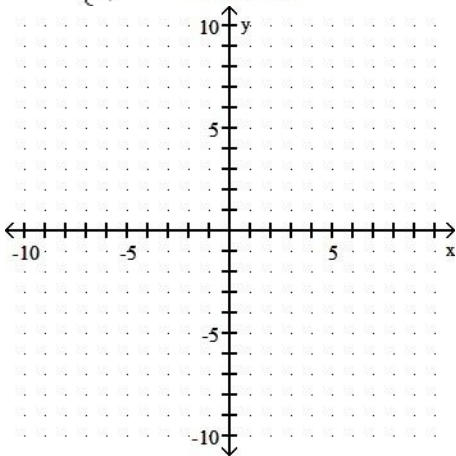

A)

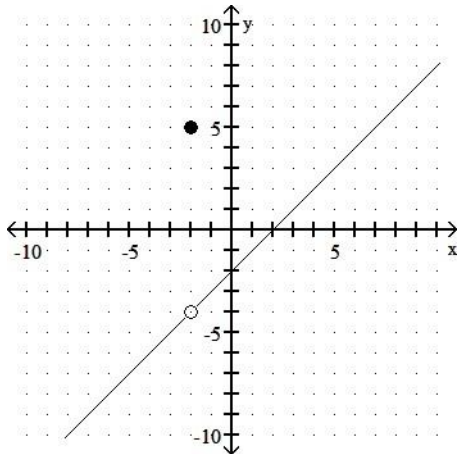

B)

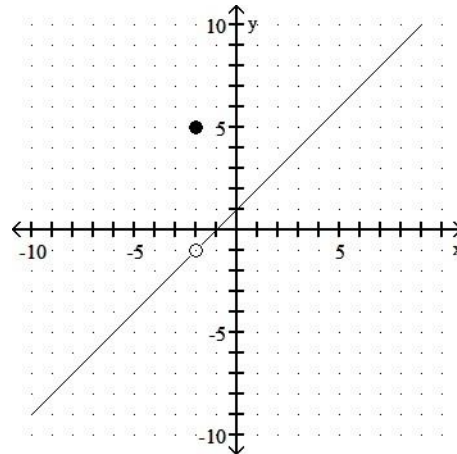

C)



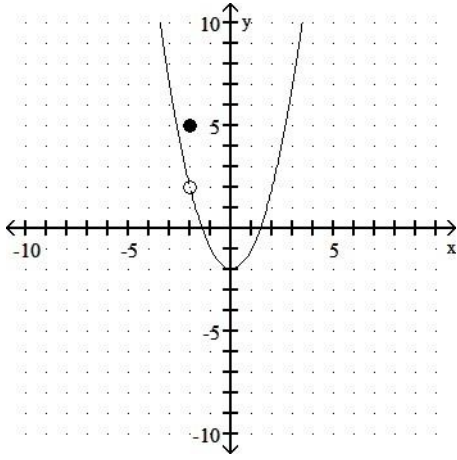

D)

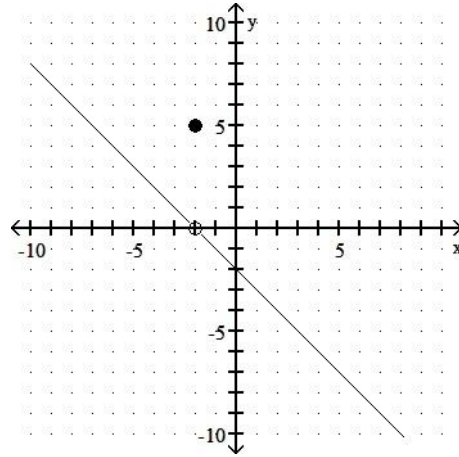

50) 
$$f(x) = \begin{cases} \frac{x^2 - 1}{x - 1}, & \text{for } x \neq 1, \\ -2, & \text{for } x = 1 \end{cases}$$

50) \_\_\_\_\_

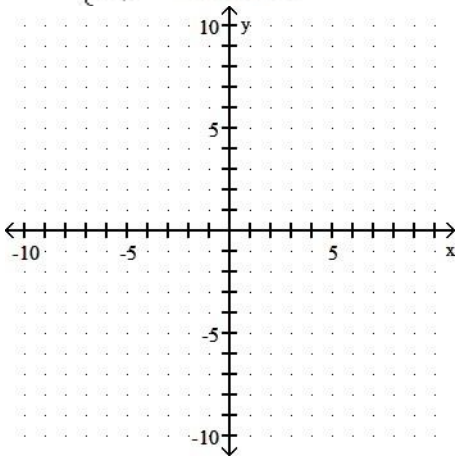

A)

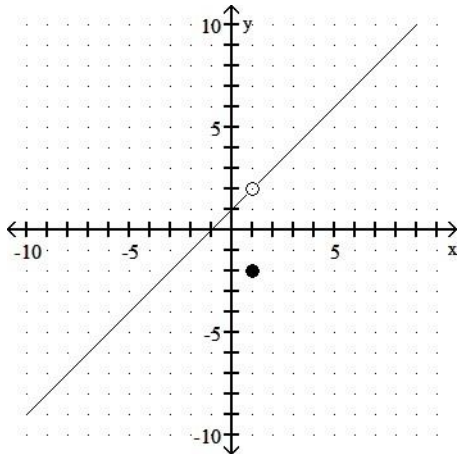

B)

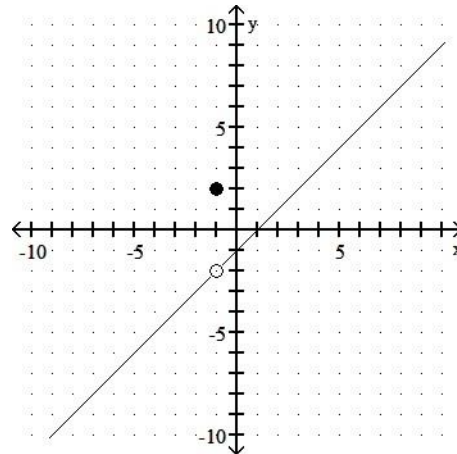

C)

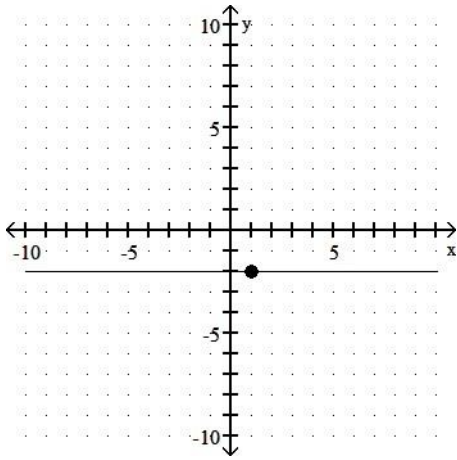

D)

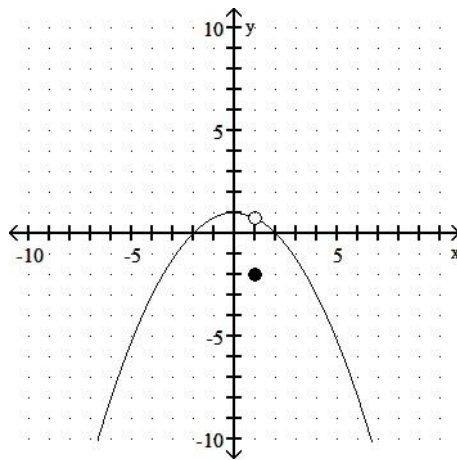

51) 
$$f(x) = \begin{cases} \frac{x^2 + 3x + 2}{x + 2}, & \text{for } x \neq -2, \\ -9, & \text{for } x = -2 \end{cases}$$

51) \_\_\_\_\_

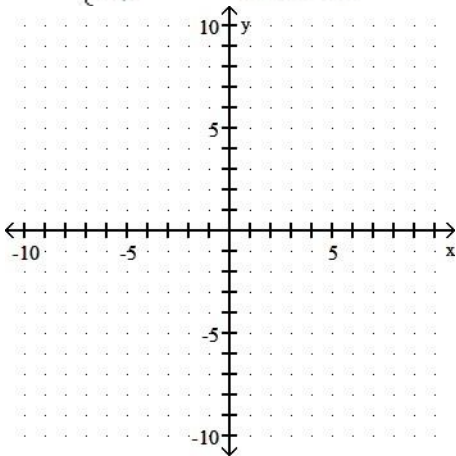

A)

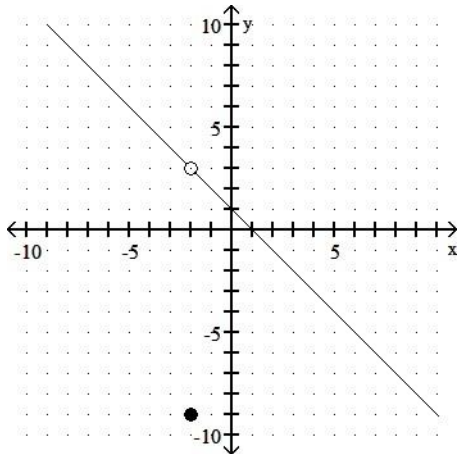

B)

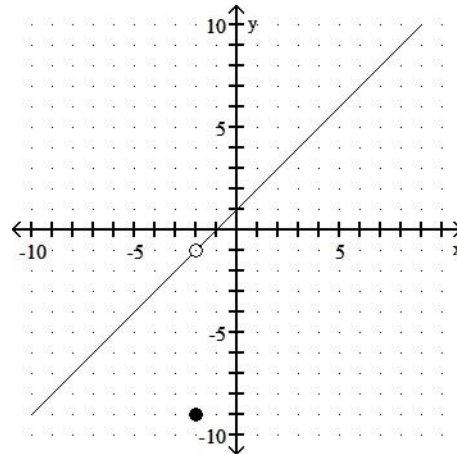

C)

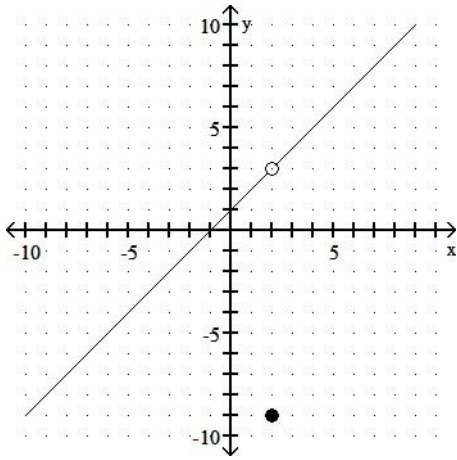

D)

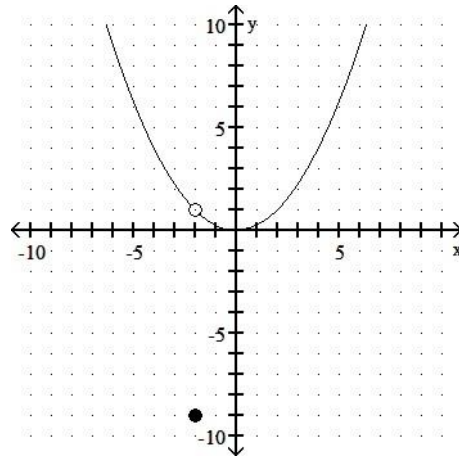

Graph the equation.

52)  $y = \lfloor x \rfloor$

52) \_\_\_\_\_

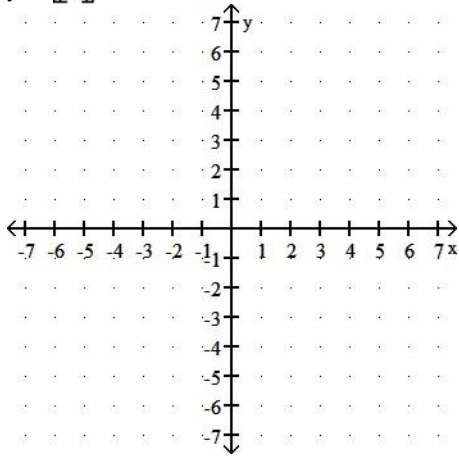

A)

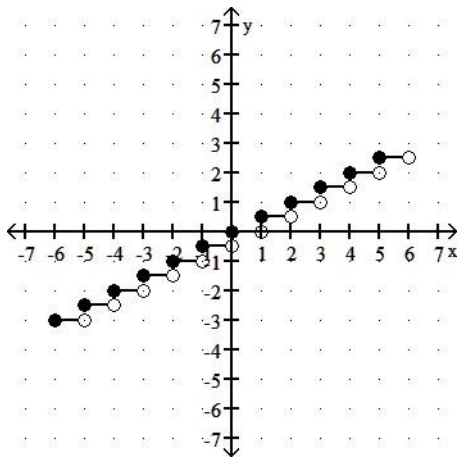

C)

B)

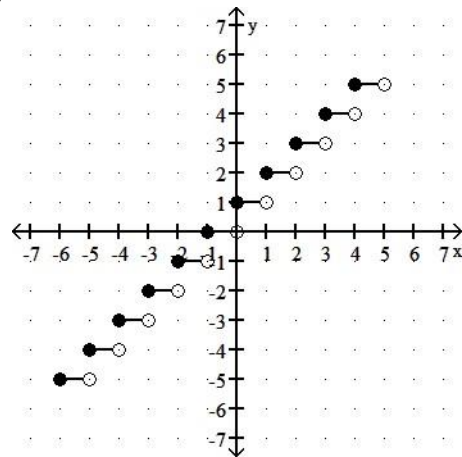

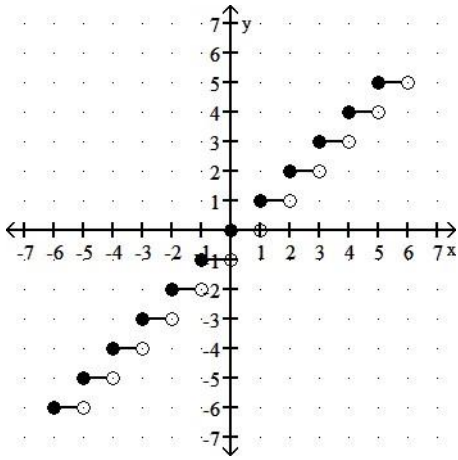

D)

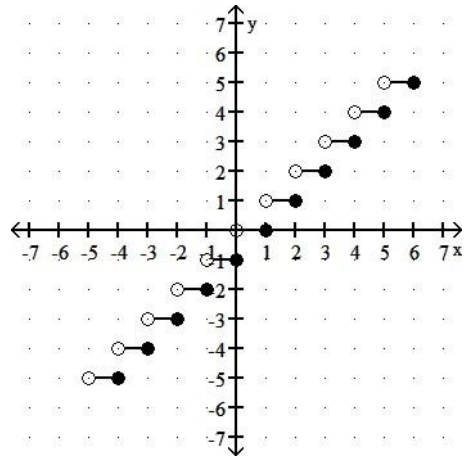

53)  $y = \frac{1}{2} \llbracket x \rrbracket$

53) \_\_\_\_\_

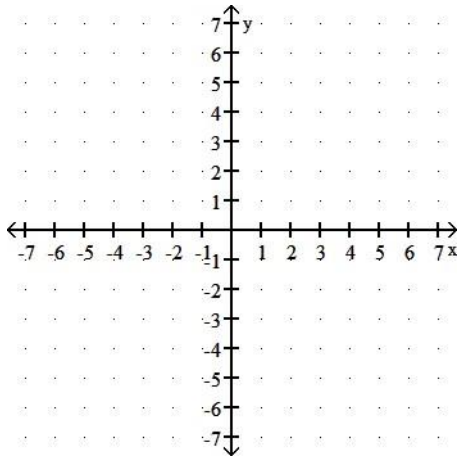

A)

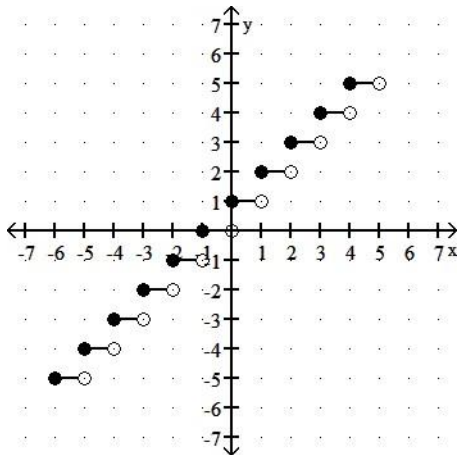

B)

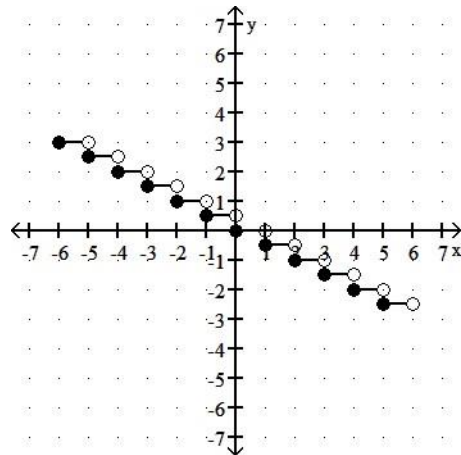

C)

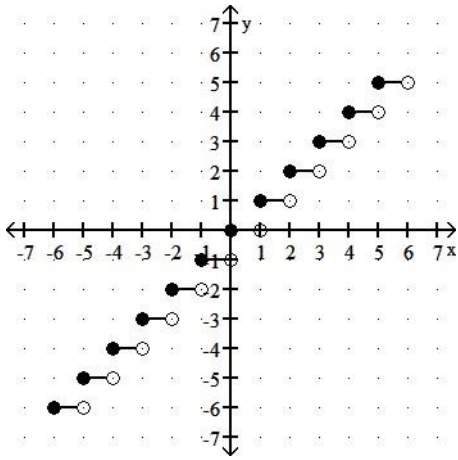

D)

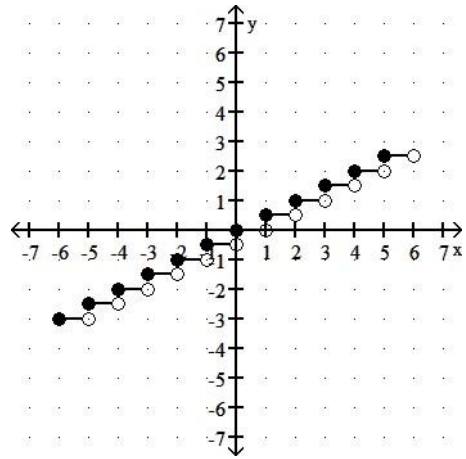

54)  $y = 3 \llbracket x \rrbracket$

54) \_\_\_\_\_

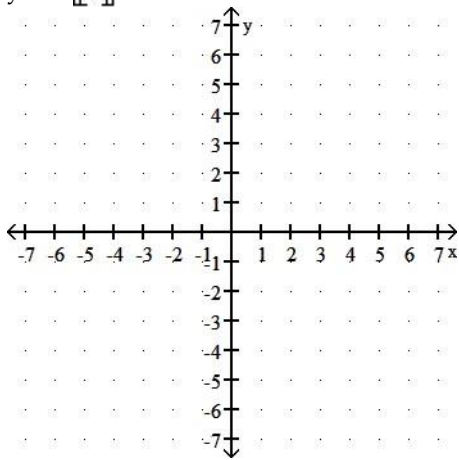

A)

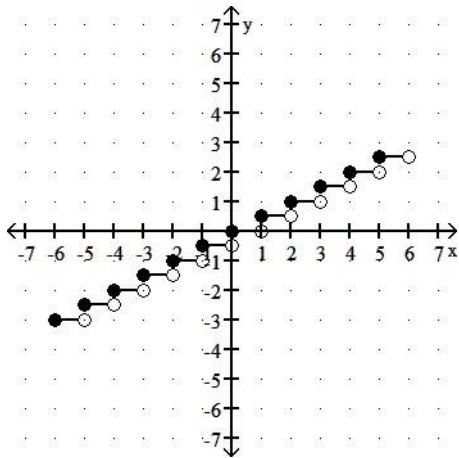

B)

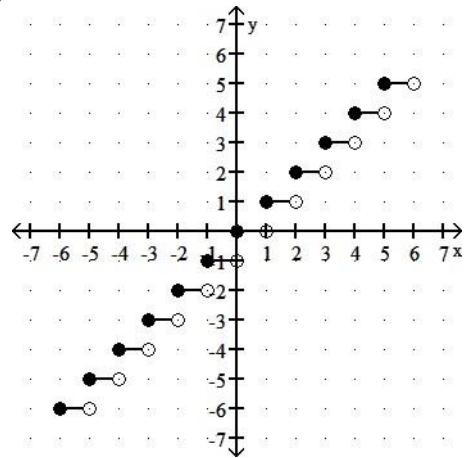

C)

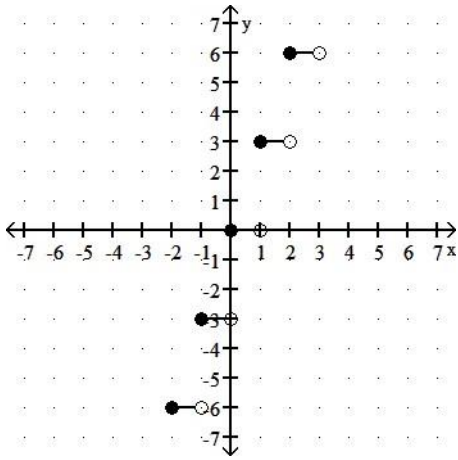

D)

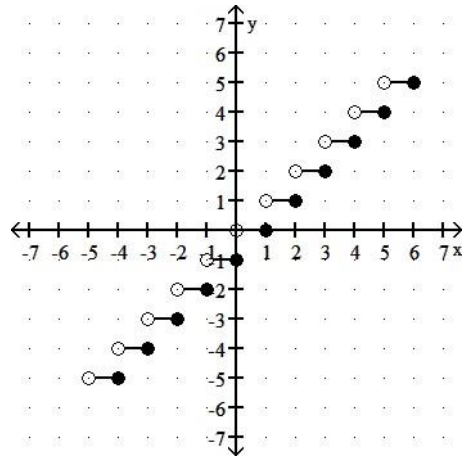

55)  $y = 2 \lfloor x \rfloor$

55) \_\_\_\_\_

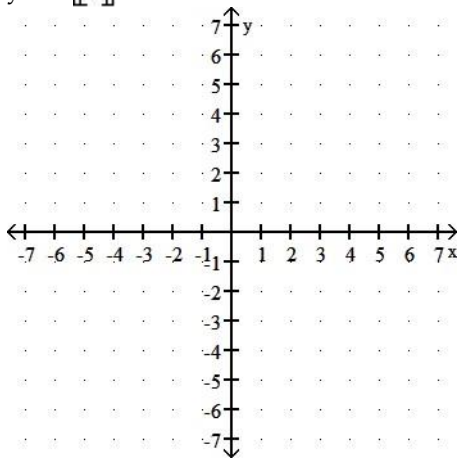

A)

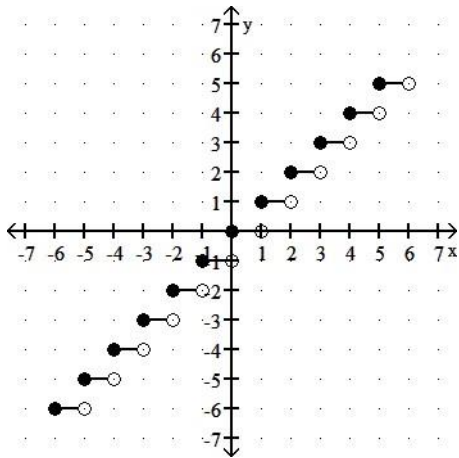

B)

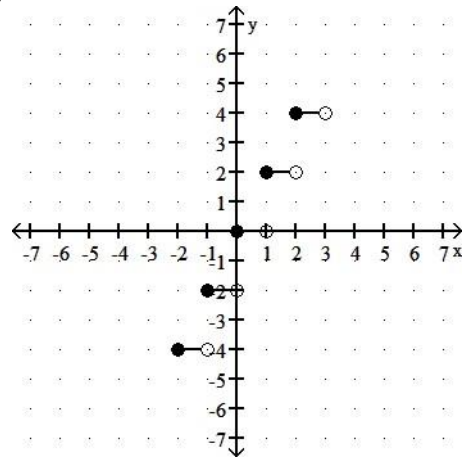

C)

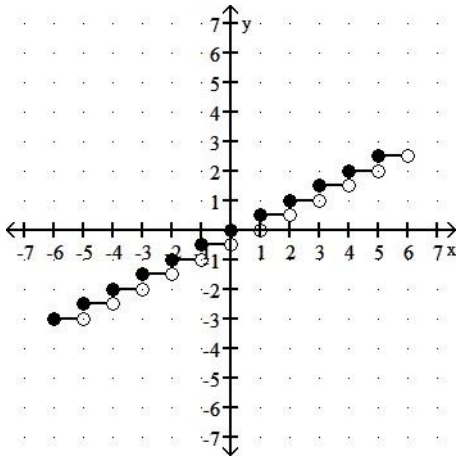

D)

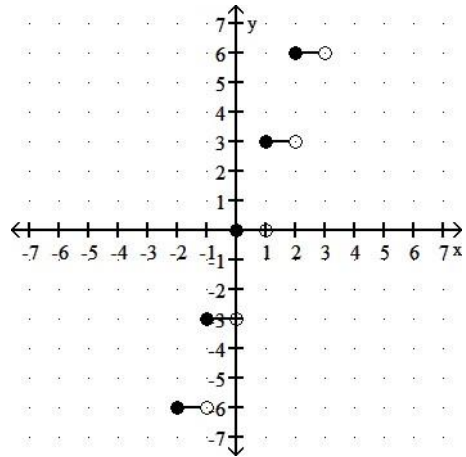

56)  $y = 3 + \lceil x \rceil$

56) \_\_\_\_\_

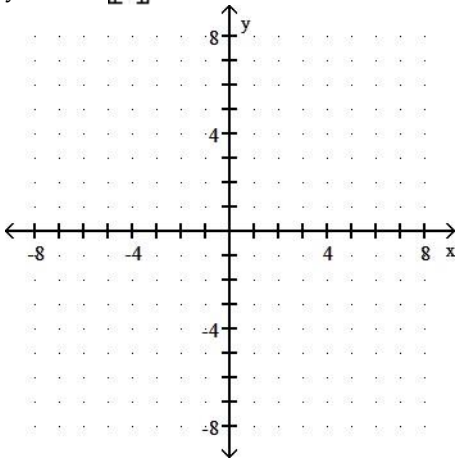

A)

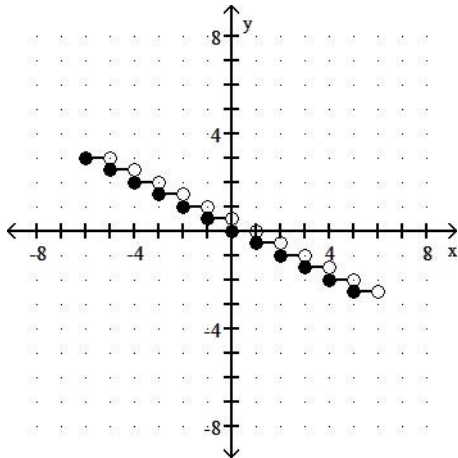

B)

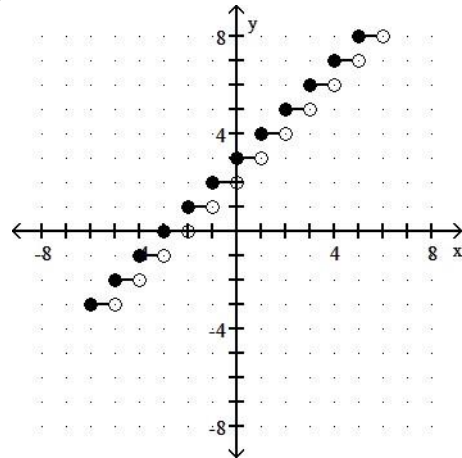

C)

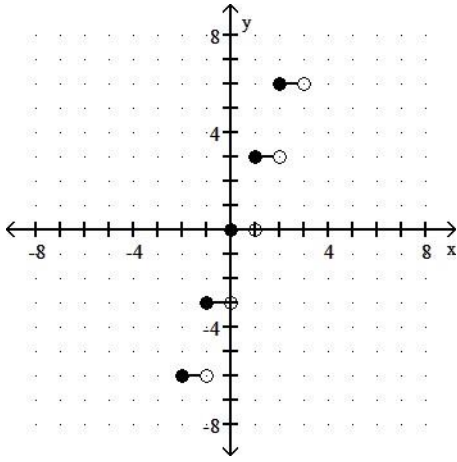

D)

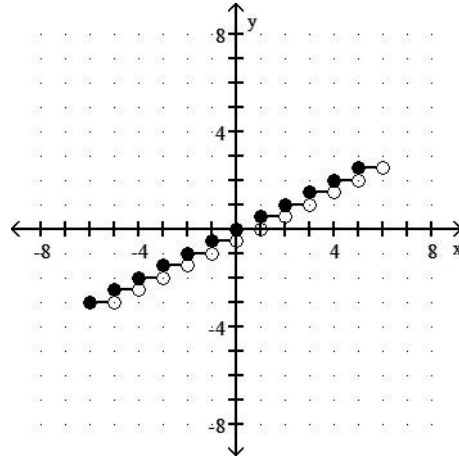

57)  $y = \frac{1}{2} \lceil x \rceil - 2$

57) \_\_\_\_\_

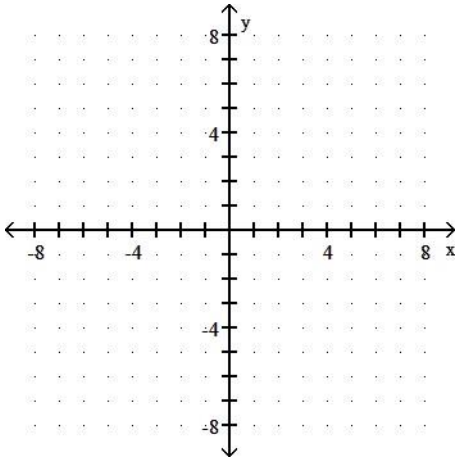

A)

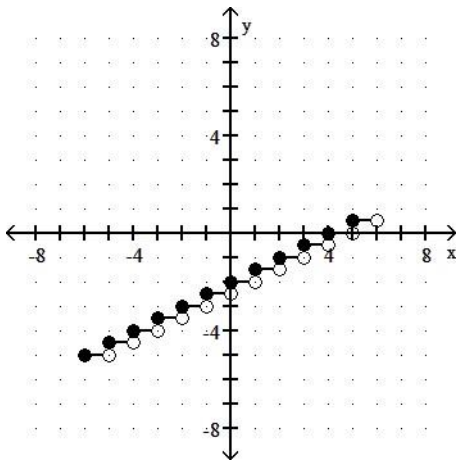

B)

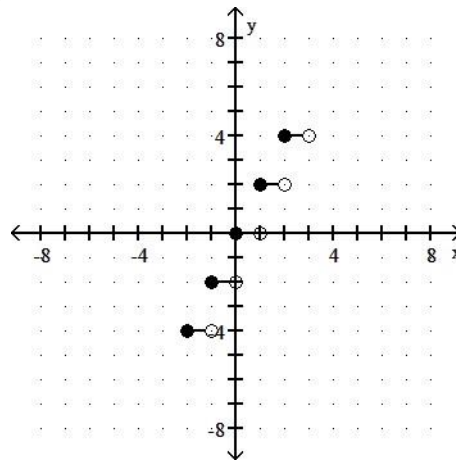

C)



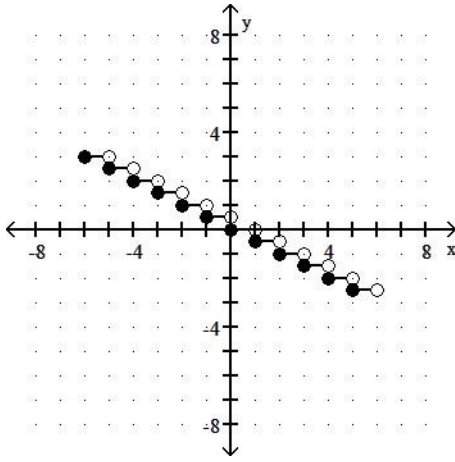

D)

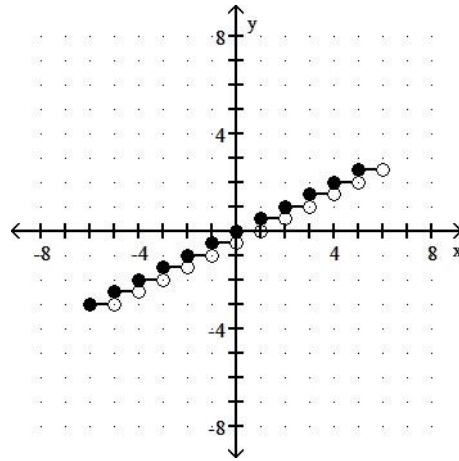

Write an equation for the piecewise function.

58)

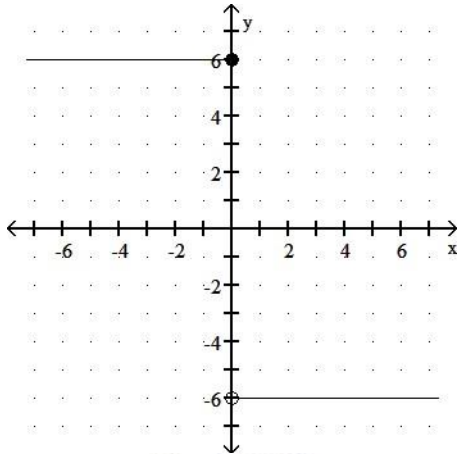

A)  $f(x) = \begin{cases} 6, & \text{for } x < 0, \\ -6, & \text{for } x \geq 0 \end{cases}$   
 C)  $f(x) = \begin{cases} 6x, & \text{for } x \leq 0, \\ -6x, & \text{for } x > 0 \end{cases}$

B)  $f(x) = \begin{cases} 6, & \text{for } x \leq 0, \\ -6, & \text{for } x > 0 \end{cases}$   
 D)  $f(x) = \begin{cases} -6, & \text{for } x \leq 0, \\ 6, & \text{for } x > 0 \end{cases}$

58) \_\_\_\_\_

59)

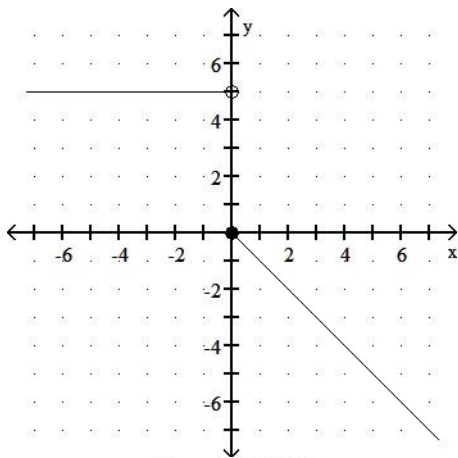

A)  $f(x) = \begin{cases} 5, & \text{for } x < 0, \\ -x, & \text{for } x \geq 0 \end{cases}$   
 C)  $f(x) = \begin{cases} 5, & \text{for } x < 0, \\ -5x, & \text{for } x \geq 0 \end{cases}$

B)  $f(x) = \begin{cases} 5, & \text{for } x < 0, \\ x, & \text{for } x \geq 0 \end{cases}$   
 D)  $f(x) = \begin{cases} 5, & \text{for } x \leq 0, \\ -x, & \text{for } x > 0 \end{cases}$

59) \_\_\_\_\_

60)

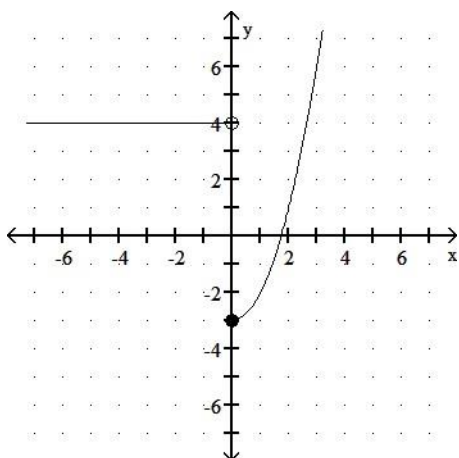

$$A) f(x) = \begin{cases} -4, & \text{for } x < 0, \\ |x| - 3, & \text{for } x \geq 0 \end{cases}$$

$$C) f(x) = \begin{cases} 4, & \text{for } x < 0, \\ x^2 - 3, & \text{for } x \geq 0 \end{cases}$$

$$B) f(x) = \begin{cases} -4, & \text{for } x \leq 0, \\ x^2 - 3, & \text{for } x > 0 \end{cases}$$

$$D) f(x) = \begin{cases} -4, & \text{for } x < 0, \\ x^2, & \text{for } x \geq 0 \end{cases}$$

60) \_\_\_\_\_

61)

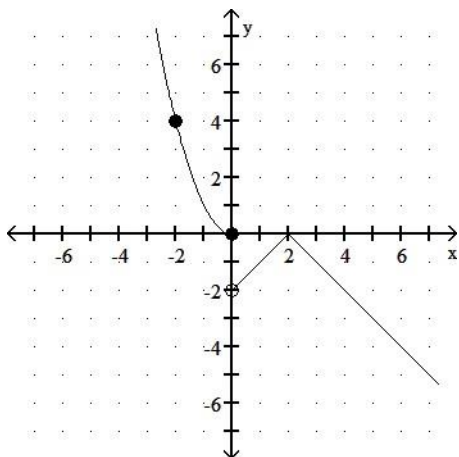

$$A) f(x) = \begin{cases} x^2, & \text{for } x \leq 0, \\ -|x - 2|, & \text{for } x > 0 \end{cases}$$

$$C) f(x) = \begin{cases} x^2, & \text{for } x \leq 0, \\ -|x + 2|, & \text{for } x > 0 \end{cases}$$

$$B) f(x) = \begin{cases} -x^2, & \text{for } x \leq 0, \\ |x - 2|, & \text{for } x > 0 \end{cases}$$

$$D) f(x) = \begin{cases} -|x - 2|, & \text{for } x < 0, \\ x^2, & \text{for } x \geq 0 \end{cases}$$

61) \_\_\_\_\_

62)

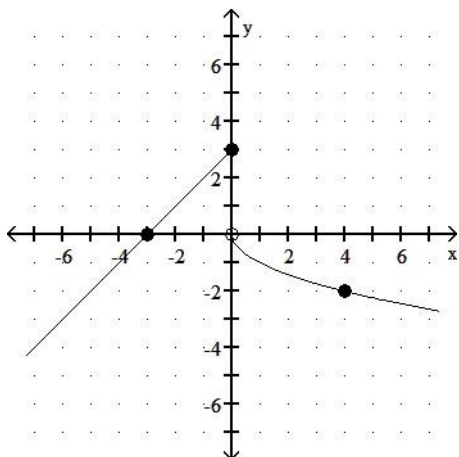

62) \_\_\_\_\_

A)  $f(x) = \begin{cases} -x + 3, & \text{for } x \leq 0, \\ -\sqrt{x}, & \text{for } x > 0 \end{cases}$   
 C)  $f(x) = \begin{cases} x - 3, & \text{for } x \leq 0, \\ -x^2, & \text{for } x > 0 \end{cases}$

B)  $f(x) = \begin{cases} x + 3, & \text{for } x \leq 0, \\ \sqrt{x}, & \text{for } x > 0 \end{cases}$   
 D)  $f(x) = \begin{cases} x + 3, & \text{for } x \leq 0, \\ -\sqrt{x}, & \text{for } x > 0 \end{cases}$

63)

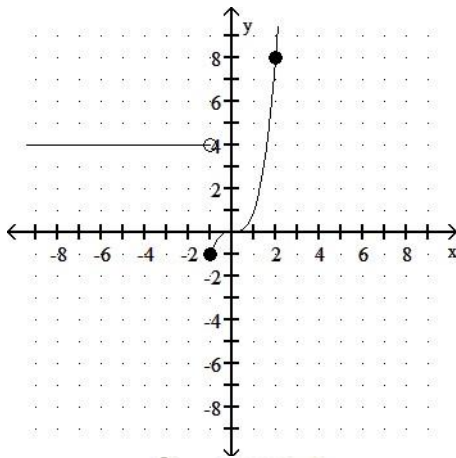

A)  $f(x) = \begin{cases} 4, & \text{for } x < -1, \\ x^2, & \text{for } x \geq -1 \end{cases}$   
 C)  $f(x) = \begin{cases} 4, & \text{for } x < -1, \\ x^3 - 1, & \text{for } x \geq -1 \end{cases}$

B)  $f(x) = \begin{cases} 4, & \text{for } x < -1, \\ x^3, & \text{for } x \geq -1 \end{cases}$   
 D)  $f(x) = \begin{cases} 4, & \text{for } x < -1, \\ x^2 - 1, & \text{for } x \geq -1 \end{cases}$

63) \_\_\_\_\_

64)

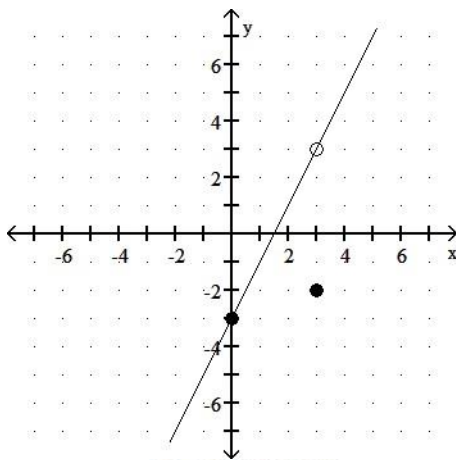

A)  $f(x) = \begin{cases} x - 3, & \text{for } x \neq 3, \\ -2, & \text{for } x = 3 \end{cases}$   
 C)  $f(x) = \begin{cases} 2x - 3, & \text{for } x < 3, \\ 2x + 3, & \text{for } x \geq 3 \end{cases}$

B)  $f(x) = \begin{cases} 2x - 3, & \text{for } x \neq 3, \\ -2, & \text{for } x = 3 \end{cases}$   
 D)  $f(x) = \begin{cases} 2x - 3, & \text{for } x \neq 3, \\ -3, & \text{for } x = 3 \end{cases}$

64) \_\_\_\_\_

65)

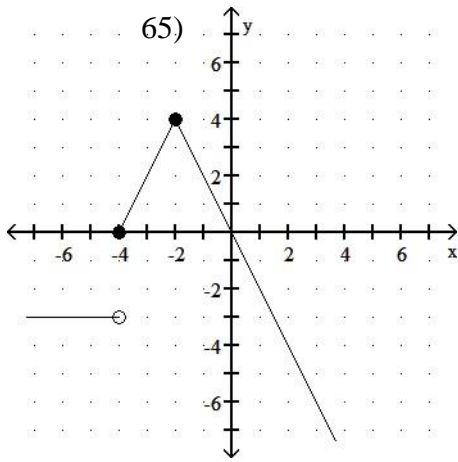

A)  $f(x) = \begin{cases} -3x, & \text{for } x < -4, \\ -2x + 2| + 4, & \text{for } x \geq -4 \end{cases}$

C)  $f(x) = \begin{cases} -3, & \text{for } x < -4, \\ -2x + 2| + 4, & \text{for } x \geq -4 \end{cases}$

B)  $f(x) = \begin{cases} -3x, & \text{for } x \leq -4, \\ -2x + 2| + 4, & \text{for } x > -4 \end{cases}$

D)  $f(x) = \begin{cases} -3, & \text{for } x \leq -4, \\ -2x + 2| + 4, & \text{for } x > -4 \end{cases}$

66)

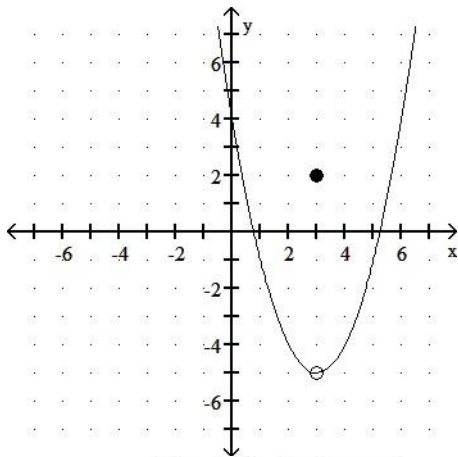

A)  $f(x) = \begin{cases} (x - 3)^2 - 5, & \text{for } x \neq 3, \\ 2, & \text{for } x = 3 \end{cases}$

C)  $f(x) = \begin{cases} (x + 3)^2 - 5, & \text{for } x \neq 3, \\ 2, & \text{for } x = 3 \end{cases}$

B)  $f(x) = \begin{cases} |x - 3| - 5, & \text{for } x \neq 3, \\ 2, & \text{for } x = 3 \end{cases}$

D)  $f(x) = (x - 3)^2 - 5$

67)

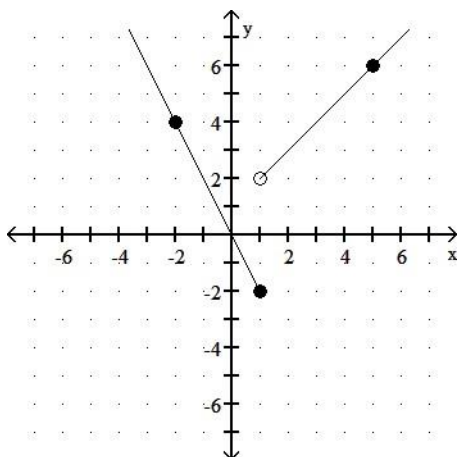

A)  $f(x) = \begin{cases} 2x, & \text{for } x \leq 1, \\ x + 1, & \text{for } x > 1 \end{cases}$

B)  $f(x) = \begin{cases} -2x, & \text{for } x \leq 1, \\ x + 2, & \text{for } x > 1 \end{cases}$

66) \_\_\_\_\_

67) \_\_\_\_\_

$$C) f(x) = \begin{cases} -x, & \text{for } x \leq 1, \\ 2x + 1, & \text{for } x > 1 \end{cases}$$

$$D) f(x) = \begin{cases} -2x, & \text{for } x \leq 1, \\ x + 1, & \text{for } x > 1 \end{cases}$$

For the pair of functions, find the indicated sum, difference, product, or quotient.

68)  $f(x) = x - 2$ ,  $g(x) = x - 7$  68) \_\_\_\_\_

Find  $(f + g)(-3)$ .

- A) -11                                      B) 3                                      C) -1                                      D) -15

69)  $f(x) = x^2 + 5$ ,  $g(x) = 4x + 1$  69) \_\_\_\_\_

Find  $(f + g)(4)$ .

- A) 22                                      B) 86                                      C) 26                                      D) 38

70)  $f(x) = -4x^2 - 3$ ,  $g(x) = x - 1$  70) \_\_\_\_\_

Find  $(f - g)(1)$ .

- A) -5                                      B) -7                                      C) -9                                      D) 6

71)  $f(x) = x - 6$ ,  $g(x) = -3x^2 + 18x + 6$  71) \_\_\_\_\_

Find  $(fg)(5)$ .

- A) -21                                      B) -121                                      C) 231                                      D) -759

72)  $f(x) = 4x - 2$ ,  $g(x) = 2x^2 + 14x + 3$  72) \_\_\_\_\_

Find  $(f/g)(-5)$ .

- A)  $\frac{1}{9}$                                       B)  $-\frac{2}{17}$                                       C)  $-\frac{4}{17}$                                       D)  $\frac{22}{17}$

73)  $f(x) = x^2 - 2$ ,  $g(x) = 6x + 1$  73) \_\_\_\_\_

Find  $(f/g)\left(-\frac{1}{6}\right)$ .

- A)  $\frac{1}{2}$                                       B)  $-\frac{2}{3}$                                       C) does not exist                                      D) 0

74)  $f(x) = x^2 - 1$ ,  $g(x) = 2x + 1$  74) \_\_\_\_\_

Find  $(f/g)(\sqrt{5})$ .

- A)  $\frac{\sqrt{5} - 1}{2}$                                       B)  $\frac{8 - \sqrt{5}}{21}$                                       C)  $\frac{8\sqrt{5} - 4}{19}$                                       D)  $\frac{7\sqrt{5} + 4}{9}$

75)  $h(x) = x + 4$ ,  $g(x) = \sqrt{x + 2}$  75) \_\_\_\_\_

Find  $(h + g)(14)$ .

- A) 26                                      B) 34                                      C) 22                                      D) 18

76)  $f(x) = x + 5$ ,  $g(x) = \sqrt{x - 2}$  76) \_\_\_\_\_

Find  $(f - g)(-5)$ .

- A) 0                                      B)  $\sqrt{2}$                                       C)  $\sqrt{7}$                                       D) does not exist

77)  $h(x) = x - 4$ ,  $g(x) = \sqrt{x + 8}$  77) \_\_\_\_\_

Find  $(hg)(-1)$ .

- A) does not exist                                      B)  $3\sqrt{7}$                                       C)  $-5 - \sqrt{7}$                                       D)  $-5\sqrt{7}$

78)  $f(x) = 8x - 4$ ,  $g(x) = 5x - 6$  78) \_\_\_\_\_

Find  $(f - g)(x)$ .

A)  $-3x - 2$

B)  $3x - 10$

C)  $3x + 2$

D)  $13x - 10$

79)  $f(x) = 6x^2 - 7x$ ,  $g(x) = x^2 - 2x - 35$

79) \_\_\_\_\_

Find  $(f/g)(x)$ .

A)  $\frac{6x^2 - 7x}{x^2 - 2x - 35}$

B)  $\frac{6x}{x+1}$

C)  $\frac{6-x}{35}$

D)  $\frac{6x-7}{-2}$

80)  $f(x) = 2 - 4x$ ,  $g(x) = -9x + 4$

80) \_\_\_\_\_

Find  $(f+g)(x)$ .

A)  $-9x + 2$

B)  $-13x + 6$

C)  $5x + 6$

D)  $-7x$

81)  $f(x) = \sqrt{3x+4}$ ,  $g(x) = \sqrt{4x-16}$

81) \_\_\_\_\_

Find  $(fg)(x)$ .

A)  $(2x - 4)(\sqrt{3x+4})$

B)  $(3x + 4)(4x - 16)$

C)  $(3x + 4)(2x - 4)$

D)  $(\sqrt{3x+4})(\sqrt{4x-16})$

82)  $f(x) = 2x - 4$ ,  $g(x) = 6x - 2$

82) \_\_\_\_\_

Find  $(fg)(x)$ .

A)  $12x^2 - 26x + 8$

B)  $8x^2 - 28x - 6$

C)  $12x^2 - 28x + 8$

D)  $12x^2 + 8$

83)  $f(x) = 7x - 9$ ,  $g(x) = 5x - 2$

83) \_\_\_\_\_

Find  $(f/g)(x)$ .

A)  $\frac{7x-9}{5x-2}$

B)  $\frac{5x+2}{7x+9}$

C)  $\frac{7x+9}{5x+2}$

D)  $\frac{5x-2}{7x-9}$

84)  $f(x) = 2 + x$ ,  $g(x) = 3|x|$

84) \_\_\_\_\_

Find  $(g/f)(x)$ .

A)  $3|x| - 2 + x$

B)  $\frac{3|x|}{2+x}$

C)  $\frac{3|x|}{2} + x$

D)  $\frac{2+x}{3|x|}$

85)  $f(x) = 16 - x^2$ ;  $g(x) = 4 - x$

85) \_\_\_\_\_

Find  $(f+g)(x)$ .

A)  $x^3 - 4x^2 - 16x + 64$

B)  $-x^2 - x + 20$

C)  $-x^2 + x + 12$

D)  $4 + x$

86)  $f(x) = \frac{8}{x-4}$ ,  $g(x) = \frac{1}{5+x}$

86) \_\_\_\_\_

Find  $(ff)(x)$ .

A)  $\frac{64}{(x-4)(5+x)}$

B)  $\frac{8}{(x-4)^2}$

C)  $\frac{64}{(x-4)^2}$

D)  $\frac{64}{x-4^2}$

87)  $f(x) = \frac{7}{x-8}$ ,  $g(x) = \frac{1}{8+x}$

87) \_\_\_\_\_

Find  $(f/g)(x)$ .

A)  $\frac{8+x}{7(x-8)}$

B)  $\frac{7(8+x)}{x-8}$

C)  $\frac{x-8}{7(8+x)}$

D)  $\frac{7}{(x-8)(8+x)}$

**For the pair of functions, find the indicated domain.**

88)  $f(x) = 2x - 5$ ,  $g(x) = \sqrt{x+3}$

Find the

domain of 88)

$f + g$ .

A)  $[-3, \infty)$

B)  $[0, \infty)$

C)  $[3, \infty)$

D)  $(-3, 3)$

89)  $f(x) = 2x - 5$ ,  $g(x) = \sqrt{x + 2}$

Find the domain of  $f/g$ .

A)  $[2, \infty)$

B)  $(-2, \infty)$

C)  $[0, \infty)$

D)  $(-2, 2)$

90)  $f(x) = x^2 - 1$ ,  $g(x) = 2x + 3$

Find the domain of  $f - g$ .

A)  $(-1, 1)$

B)  $(-\infty, \infty)$

C)  $[0, \infty)$

D)  $[1, \infty)$

91)  $f(x) = x^2 - 36$ ,  $g(x) = 2x + 3$

Find the domain of  $f/g$ .

A)  $(-6, 6)$

C)  $(-\infty, \infty)$

B)  $\left[-\frac{3}{2}, \infty\right)$   
D)  $\left(-\infty, -\frac{3}{2}\right) \cup \left[-\frac{3}{2}, \infty\right)$

92)  $f(x) = x^2 - 36$ ,  $g(x) = 2x + 3$

Find the domain of  $g/f$ .

A)  $\left[-\frac{3}{2}, \infty\right)$

C)  $(-\infty, \infty)$

B)  $(-\infty, -6) \cup (-6, 6) \cup (6, \infty)$

D)  $\left(-\infty, -\frac{3}{2}\right) \cup \left[\frac{3}{2}, \infty\right)$

93) For  $f(x) = \sqrt{x - 1}$  and  $g(x) = \frac{1}{x - 8}$

Find the domain of  $fg$ .

A)  $[0, 8) \cup (8, \infty)$

B)  $(1, 8) \cup (8, \infty)$

C)  $[1, 8) \cup (8, \infty)$

D)  $[1, \infty)$

94)  $f(x) = \sqrt{6 - x}$ ;  $g(x) = \sqrt{x - 2}$

Find the domain of  $fg$ .

A)  $(-\infty, 2) \cup (6, \infty)$

C)  $[2, 6]$

B)  $(-\infty, 12) \cup (12, \infty)$

D)  $(2, 6)$

95)  $f(x) = 2x + 3$ ,  $g(x) = \frac{3}{x + 8}$

Find the domain of  $f + g$ .

A)  $(-\infty, \infty)$

C)  $(-\infty, -3)$  or  $(-3, \infty)$

B)  $(0, \infty)$

D)  $(-\infty, -8)$  or  $(-8, \infty)$

96)  $f(x) = \frac{3x}{x - 4}$ ,  $g(x) = \frac{4}{x + 7}$

Find the domain of  $f + g$ .

A)  $(-\infty, -4) \cup (-4, -3) \cup (-3, \infty)$

C)  $(-\infty, \infty)$

B)  $(-\infty, -7) \cup (-7, 4) \cup (4, \infty)$

D)  $(-\infty, -4) \cup (-4, 7) \cup (7, \infty)$

97)  $f(x) = 3x^2 + 6$ ,  $g(x) = 2x^3 + 4$

Find the domain of  $f + g$ .

—  
—

89) —

90) —

91) —

92) —

93) —

94) —

95) —

96) —

97) —

- A)  $(-\infty, 0) \cup (0, \infty)$   
 C)  $(-\infty, -3) \cup (-3, -2) \cup (-2, \infty)$

- B)  $(0, \infty)$   
 D)  $(-\infty, \infty)$

Consider the functions F and G as shown in the graph. Provide an appropriate response.

98) Find the domain of  $F + G$ .

98) \_\_\_\_\_

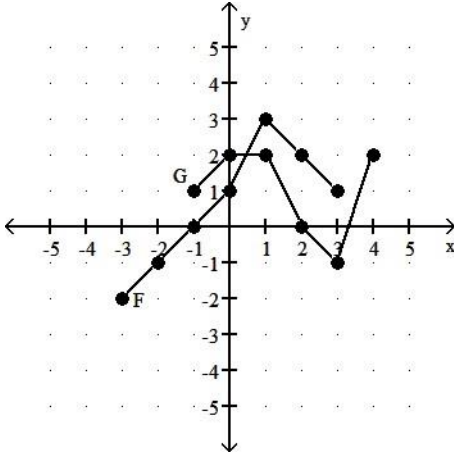

- A)  $[-1, 3]$                       B)  $[-3, 4]$                       C)  $[-1, 4]$                       D)  $[-3, 3]$

99) Find the domain of  $F - G$ .

99) \_\_\_\_\_

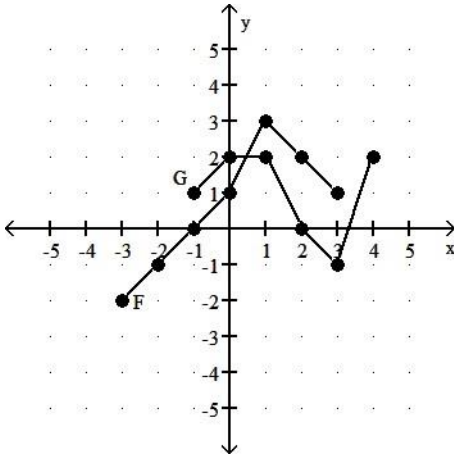

- A)  $[-3, 3]$                       B)  $[-1, 4]$                       C)  $[-3, 4]$                       D)  $[-1, 3]$

100) Find the domain of  $FG$ .

100) \_\_\_\_\_

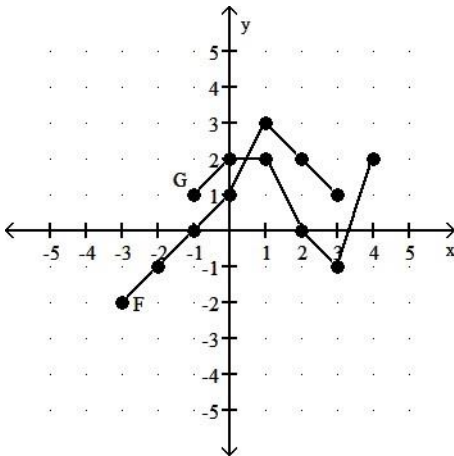

- A)  $[-3, 3]$                       B)  $[-1, 3]$                       C)  $[-1, 4]$                       D)  $[-3, 4]$

101) Find the domain of  $F/G$ .



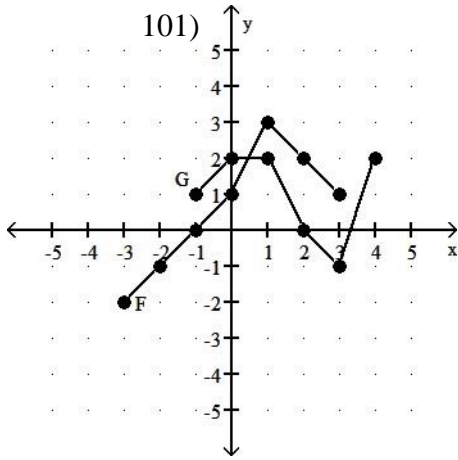

- A)  $[-3, -1) \cup (-1, 4)$       B)  $[-1, 3]$       C)  $[-1, 2) \cup (2, 3]$       D)  $[-3, 4]$

102) Find the domain of  $G/F$ .

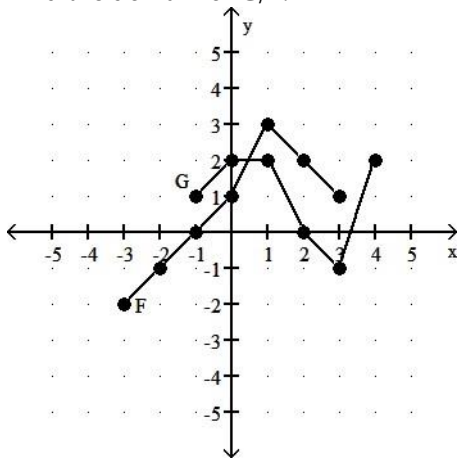

- A)  $[-3, 3]$       B)  $[-3, 4]$       C)  $[-1, 2) \cup (2, 3]$       D)  $(-1, 3]$

103) Graph  $F + G$ .

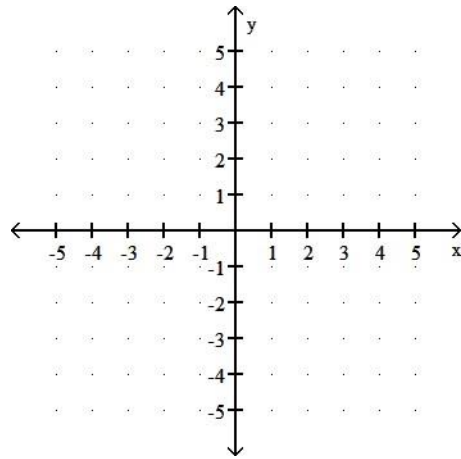
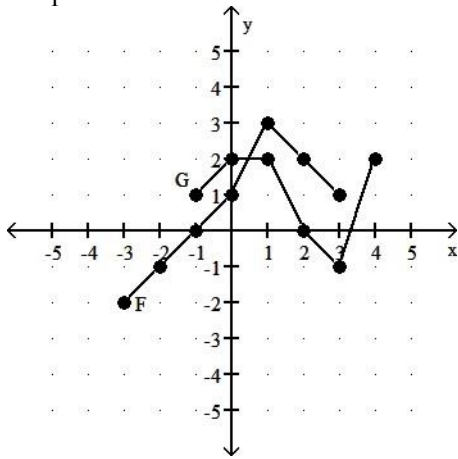

A)

102) \_\_\_\_\_

103) \_\_\_\_\_

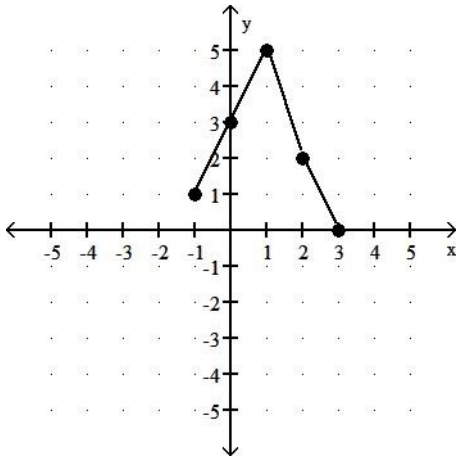

B)

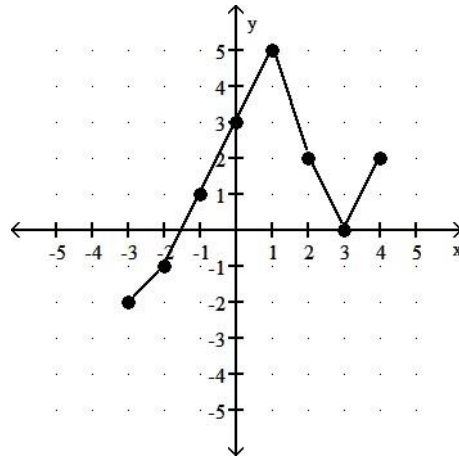

C)

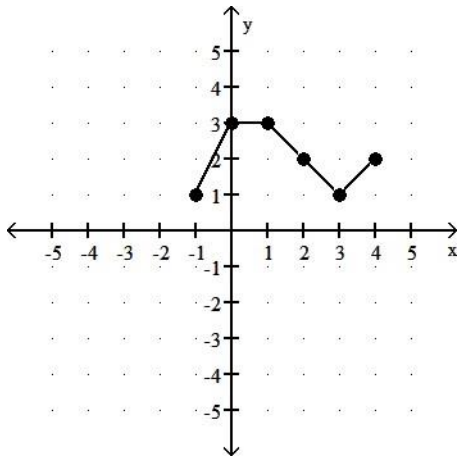

D)

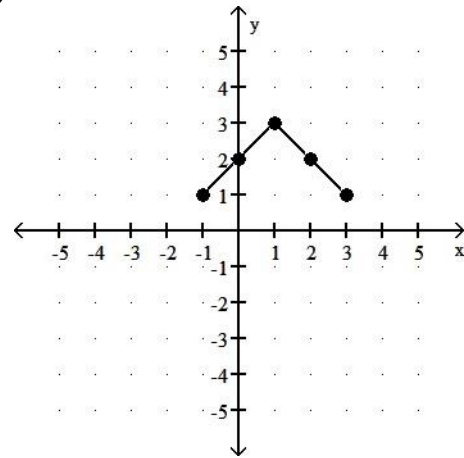

104) Graph F - G.

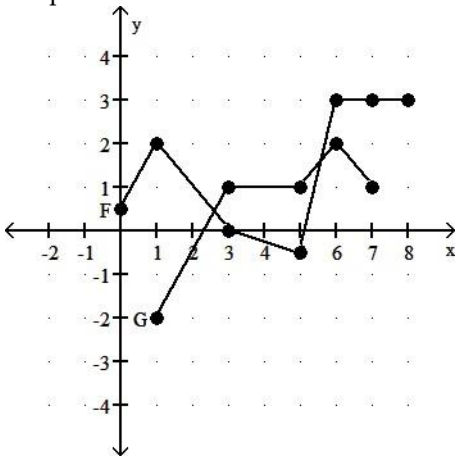

A)

104) \_\_\_\_\_

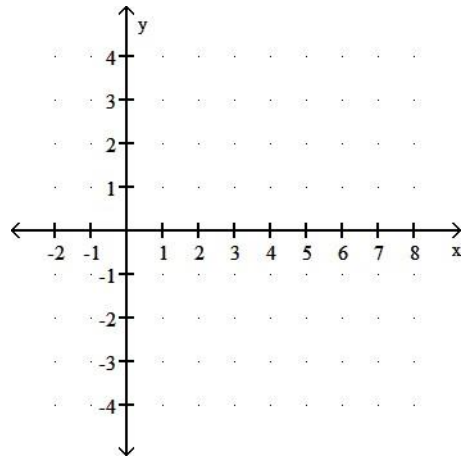

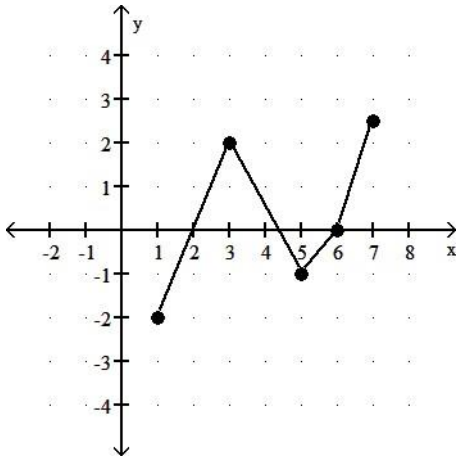

B)

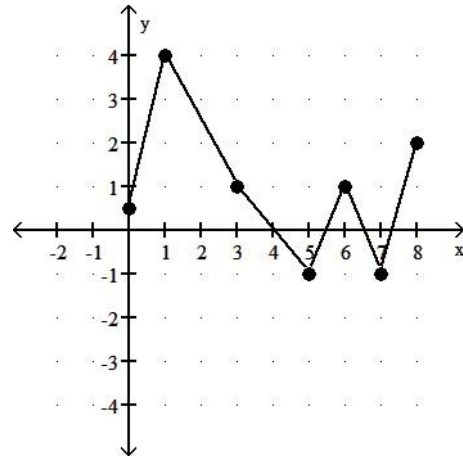

C)

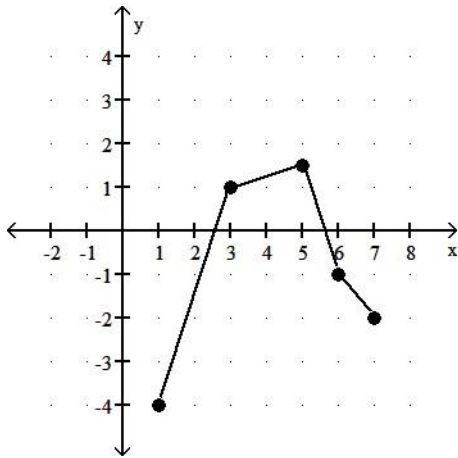

D)

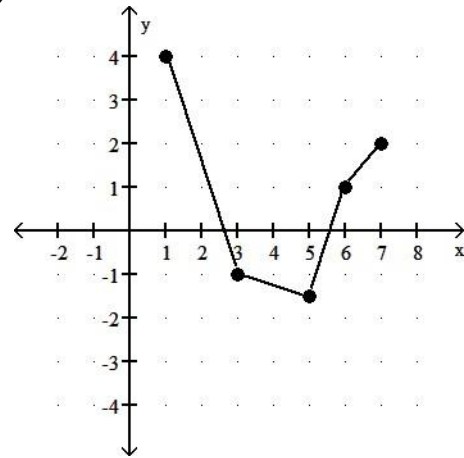

105) Graph G - F.

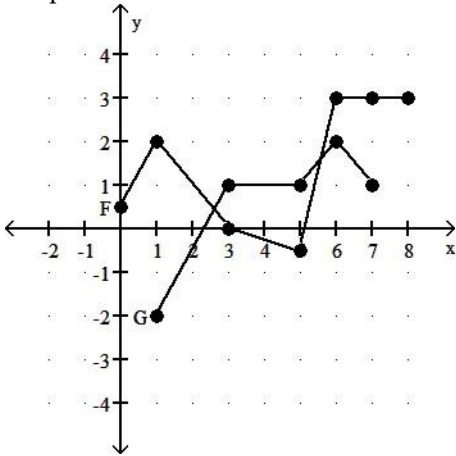

A)

105) \_\_\_\_\_

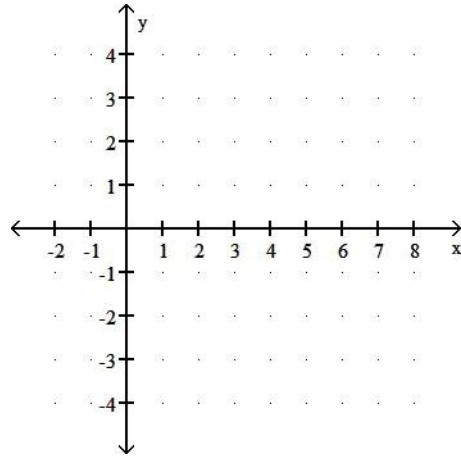

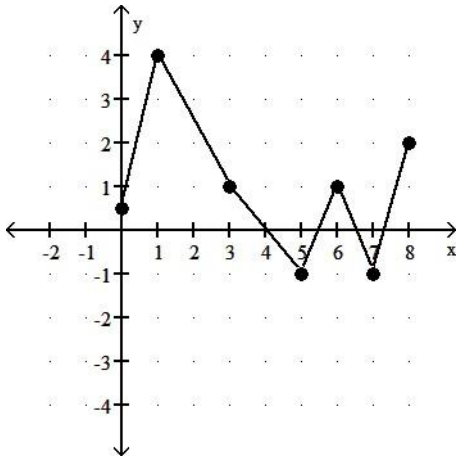

B)

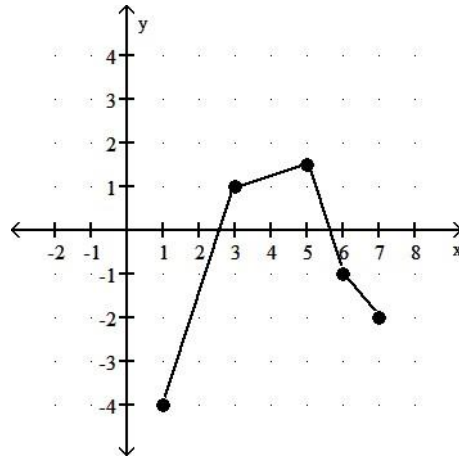

C)

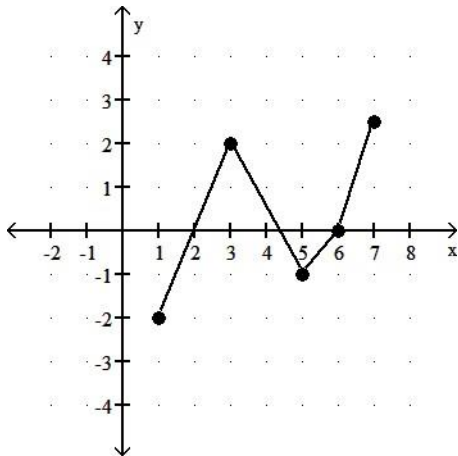

D)

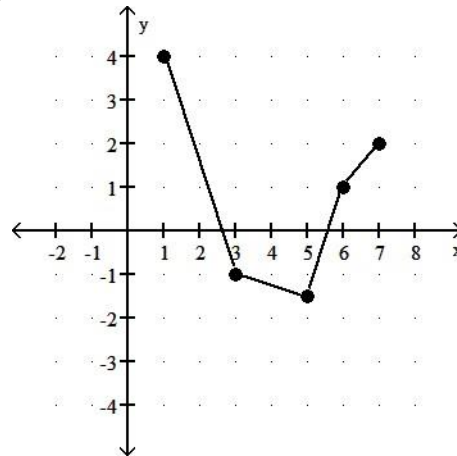

Solve.

106) At Allied Electronics, production has begun on the X-15 Computer Chip. The total revenue function is given by  $R(x) = 49x - 0.3x^2$  and the total cost function is given by  $C(x) = 9x + 15$ , where  $x$  represents the number of boxes of computer chips produced. The total profit function,  $P(x)$ , is such that  $P(x) = R(x) - C(x)$ . Find  $P(x)$ .

106) \_\_\_\_\_

A)  $P(x) = -0.3x^2 + 31x + 15$

B)  $P(x) = 0.3x^2 + 40x - 30$

C)  $P(x) = 0.3x^2 + 31x - 45$

D)  $P(x) = -0.3x^2 + 40x - 15$

107) At Allied Electronics, production has begun on the X-15 Computer Chip. The total revenue function is given by  $R(x) = 57x - 0.3x^2$  and the total profit function is given by  $P(x) = -0.3x^2 + 54x - 15$ , where  $x$  represents the number of boxes of computer chips produced. The total cost function,  $C(x)$ , is such that  $C(x) = R(x) - P(x)$ . Find  $C(x)$ .

107) \_\_\_\_\_

A)  $C(x) = -0.3x^2 + 6x + 15$

B)  $C(x) = 5x + 11$

C)  $C(x) = 4x + 20$

D)  $C(x) = 3x + 15$

108) At Allied Electronics, production has begun on the X-15 Computer Chip. The total cost function is given by  $C(x) = 4x + 8$  and the total profit function is given by  $P(x) = -0.3x^2 + 52x - 8$ , where  $x$  represents the number of boxes of computer chips produced. The total revenue function,  $R(x)$ , is such that  $R(x) = C(x) + P(x)$ . Find  $R(x)$ .

108) \_\_\_\_\_

A)  $R(x) = 56x - 0.3x^2$

B)  $R(x) = 56x + 0.3x^2$

C)  $R(x) = 58x - 0.3x^2$

D)  $R(x) = 55x - 0.6x^2$

- 109) AAA Technology finds that the total revenue function associated with producing a new type of computer chip is  $R(x) = 64 - 0.3x^2$ , and the total cost function is  $C(x) = 3x + 22$ , where  $x$  represents the number of units of chips produced. Find the total profit function,  $P(x)$ .
- A)  $P(x) = -0.03x^2 - 3x + 42$       B)  $P(x) = 0.03x^2 + 3x + 44$   
 C)  $P(x) = -0.03x^2 + 3x + 86$       D)  $P(x) = -0.03x^2 + 3x - 42$

- 110) Acme Communication finds that the total revenue function associated with producing a new type of cellular phone is  $R(x) = 210x - x^2$ , and the total cost function is  $C(x) = 6000 + 6x$ , where  $x$  represents the number of units of cellular phones produced. Find the total profit function,  $P(x)$ .
- A)  $P(x) = -x^2 + 204x - 6000$       B)  $P(x) = x^2 - 204x^2 + 6000$   
 C)  $P(x) = -x^2 + 216x + 6000$       D)  $P(x) = -2x^2 + 222x - 7000$

For the function  $f$ , construct and simplify the difference quotient  $\frac{f(x+h) - f(x)}{h}$ .

- 111)  $f(x) = 6x + 4$       111) \_\_\_\_\_
- A)  $6 + \frac{12(x+4)}{h}$       B)  $6 + \frac{8}{h}$       C) 6      D) 0

- 112)  $f(x) = \frac{1}{5x}$       112) \_\_\_\_\_
- A) 0      B)  $\frac{-1}{x(x+h)}$       C)  $\frac{-1}{5x(x+h)}$       D)  $\frac{1}{5x}$

- 113)  $f(x) = \frac{5}{x+17}$       113) \_\_\_\_\_
- A)  $-\frac{5}{(x+h+17)(x+17)}$       B)  $-\frac{85}{(x+h+17)(x+17)}$   
 C)  $-\frac{5}{(x+5)^2}$       D)  $\frac{5}{(x+h+17)(x+17)}$

- 114)  $f(x) = \frac{x}{4-x}$       114) \_\_\_\_\_
- A)  $\frac{x}{(4-x+h)(4-x)}$       B)  $-\frac{4}{(4-x+h)(4-x)}$   
 C)  $\frac{4}{(4-x-h)(4-x)}$       D)  $\frac{hx}{(4-x-h)(4+x)}$

- 115)  $f(x) = \frac{x-28}{x+3}$       115) \_\_\_\_\_
- A)  $\frac{31(x+h+3)}{(x+3)}$       B)  $\frac{32}{(x+3)(x-3)}$   
 C)  $-\frac{31}{x(x+3)}$       D)  $\frac{31}{(x+h+3)(x+3)}$

- 116)  $f(x) = 4 - 10x^3$       116) \_\_\_\_\_
- A)  $-10(3x^2 + 3xh + h^2)$       B)  $-10(x^2 - xh - h^2)$   
 C)  $-10(3x^2 - 3x - h)$       D)  $-12x^2$

117)  $f(x) = 8x^2 + 5x$  117) \_\_\_\_\_  
 A)  $16x^2 + 8h + 5x$  B)  $16x + 5$  C)  $24x - 10h + 10$  D)  $16x + 8h + 5$

118)  $f(x) = 2|x| + 9x$  118) \_\_\_\_\_  
 A)  $-10h$  B)  $-8h$   
 C)  $\frac{-2|x+h| - 10h + 2|x|}{h}$  D)  $\frac{2|x+h| - 9h - 2|x|}{h}$

Find the requested function value.

119)  $f(x) = \frac{x-5}{9}$ ,  $g(x) = 7x + 1$  119) \_\_\_\_\_

Find  $(g \circ f)(41)$ .

A) 32 B)  $\frac{283}{9}$  C) 1152 D) 29

120)  $f(x) = 3x + 8$ ,  $g(x) = 7x^2 - 2x - 3$  120) \_\_\_\_\_

Find  $(f \circ g)(9)$ .

A) 8502 B) 134 C) 172 D) 1646

121)  $f(x) = 8x + 4$ ,  $g(x) = -7x^2 + 5x + 1$  121) \_\_\_\_\_

Find  $(g \circ f)(-8)$ .

A) -25,499 B) 140 C) 121 D) -3892

122)  $f(x) = \frac{x-5}{2}$ ,  $g(x) = 7x + 2$  122) \_\_\_\_\_

Find  $(g \circ f)(15)$ .

A) 535 B) 51 C) 45 D) 37

For the pair of functions, find the indicated composition.

123)  $f(x) = 4x + 13$ ,  $g(x) = 3x - 1$  123) \_\_\_\_\_

Find  $(f \circ g)(x)$ .

A)  $12x + 9$  B)  $12x + 17$  C)  $12x + 38$  D)  $12x + 12$

124)  $f(x) = -4x + 7$ ,  $g(x) = 2x + 3$  124) \_\_\_\_\_

Find  $(g \circ f)(x)$ .

A)  $-8x + 17$  B)  $-8x - 11$  C)  $-8x + 19$  D)  $8x + 17$

125)  $f(x) = \frac{3}{x-5}$ ,  $g(x) = \frac{4}{5x}$  125) \_\_\_\_\_

Find  $(f \circ g)(x)$ .

A)  $\frac{4x-20}{15x}$  B)  $\frac{3x}{4-25x}$  C)  $\frac{15x}{4+25x}$  D)  $\frac{15x}{4-25x}$

126)  $f(x) = \frac{x-9}{4}$ ,  $g(x) = 4x + 9$  126) \_\_\_\_\_

Find  $(g \circ f)(x)$ .

A)  $x$  B)  $x + 18$  C)  $4x + 27$  D)  $x - \frac{9}{4}$

127)  $f(x) = \sqrt{x+4}$ ,  $g(x) = 8x - 8$  127) \_\_\_\_\_

Find  $(f \circ g)(x)$ .

- A)  $2\sqrt{2x+1}$       B)  $2\sqrt{2x-1}$       C)  $8\sqrt{x-4}$       D)  $8\sqrt{x+4} - 8$

128)  $f(x) = 4x^2 + 3x + 5$ ,  $g(x) = 3x - 3$  128) \_\_\_\_\_

Find  $(g \circ f)(x)$ .

- A)  $4x^2 + 9x + 12$       B)  $12x^2 + 9x + 12$       C)  $12x^2 + 9x + 18$       D)  $4x^2 + 3x + 2$

129)  $f(x) = \frac{4}{x}$ ,  $g(x) = 3x^6$  129) \_\_\_\_\_

Find  $(g \circ f)(x)$ .

- A)  $\frac{3x^6}{4}$       B)  $\frac{12,288}{x^6}$       C)  $\frac{4}{3x^6}$       D)  $\frac{3x^6}{4096}$

130)  $f(x) = \frac{9}{8}x$ ,  $g(x) = -\frac{8}{9}x$  130) \_\_\_\_\_

Find  $(f \circ g)(x)$ .

- A)  $x$       B)  $-x$       C)  $0$       D)  $1$

131)  $f(x) = x^3 + 2$ ,  $g(x) = \sqrt[3]{x-2}$  131) \_\_\_\_\_

Find  $(g \circ f)(x)$ .

- A)  $x^3$       B)  $|x|$       C)  $-x$       D)  $x$

132)  $f(x) = x^3 + 4x^2 - 2x - 8$ ,  $g(x) = x - 1$  132) \_\_\_\_\_

Find  $(f \circ g)(x)$ .

- A)  $x^3 + 7x^2 + 9x - 5$       B)  $x^3 + 1x^2 - 7x - 3$   
 C)  $x^3 + 4x^2 - 2x - 9$       D)  $x^3 + 4x^2 - 2x - 7$

**For the pair of functions, find the indicated domain.**

133)  $f(x) = 3x + 21$ ,  $g(x) = x + 9$  133) \_\_\_\_\_

Find the domain of  $f \circ g$ .

- A)  $(-\infty, 16) \cup (16, \infty)$       B)  $(-\infty, -16) \cup (-16, \infty)$   
 C)  $(-\infty, -16] \cup [-16, \infty)$       D)  $(-\infty, \infty)$

134)  $f(x) = \frac{2}{x+3}$ ,  $g(x) = x + 2$  134) \_\_\_\_\_

Find the domain of  $f \circ g$ .

- A)  $(-\infty, -5) \cup (-5, \infty)$       B)  $(-\infty, -5] \cup [-5, \infty)$   
 C)  $(-\infty, -3) \cup (-3, \infty)$       D)  $(-\infty, \infty)$

135)  $f(x) = \frac{10}{x+5}$ ,  $g(x) = x + 3$  135) \_\_\_\_\_

Find the domain of  $g \circ f$ .

- A)  $(-\infty, -5) \cup (-5, \infty)$       B)  $(-\infty, \infty)$   
 C)  $(-\infty, -5] \cup [-5, \infty)$       D)  $(-\infty, -8) \cup (-8, \infty)$

136)  $f(x) = 2x - 5$ ,  $g(x) = \sqrt{x+3}$  136) \_\_\_\_\_

Find the domain of  $f \circ g$ .

- A)  $[3, \infty)$       B)  $[-3, \infty)$       C)  $[0, \infty)$       D)  $(-3, 3)$

137)  $f(x) = 2x - 5$ ,  $g(x) = \sqrt{x+3}$  137) \_\_\_\_\_  
 Find the domain of  $g \circ f$ .  
 A)  $[1, \infty)$                       B)  $[-\infty, 1)$                       C)  $[3, \infty)$                       D)  $(-3, 3)$

138)  $f(x) = x^2 - 16$ ,  $g(x) = 2x + 3$  138) \_\_\_\_\_  
 Find the domain of  $f \circ g$ .  
 A)  $(-\infty, \infty)$                       B)  $[0, \infty)$                       C)  $(-4, 4)$                       D)  $[4, \infty)$

139)  $f(x) = x^2 - 16$ ,  $g(x) = 2x + 3$  139) \_\_\_\_\_  
 Find the domain of  $g \circ f$ .  
 A)  $(-\infty, \infty)$                       B)  $(-4, 4)$   
 C)  $\left[-\infty - \frac{3}{2}\right] \cup \left[-\frac{3}{2}, \infty\right)$                       D)  $\left[-\frac{3}{2}, \infty\right)$

140)  $f(x) = \sqrt{x}$ ,  $g(x) = 3x + 15$  140) \_\_\_\_\_  
 Find the domain of  $f \circ g$ .  
 A)  $[-5, \infty)$                       B)  $[0, \infty)$                       C)  $(-\infty, \infty)$                       D)  $(-\infty, -5] \cup [0, \infty)$

141)  $f(x) = x^2 - 4$ ,  $g(x) = 2x + 3$  141) \_\_\_\_\_  
 Find the domain of  $g \circ f$ .  
 A)  $[2, \infty)$                       B)  $\left[-\infty - \frac{3}{2}\right] \cup \left[-\frac{3}{2}, \infty\right)$   
 C)  $(-\infty, \infty)$                       D)  $(-2, 2)$

**Find  $f(x)$  and  $g(x)$  such that  $h(x) = (f \circ g)(x)$ .**

142)  $h(x) = \frac{1}{x^2 - 6}$  142) \_\_\_\_\_  
 A)  $f(x) = \frac{1}{6}$ ,  $g(x) = x^2 - 6$                       B)  $f(x) = \frac{1}{x}$ ,  $g(x) = x^2 - 6$   
 C)  $f(x) = \frac{1}{x^2}$ ,  $g(x) = -\frac{1}{6}$                       D)  $f(x) = \frac{1}{x^2}$ ,  $g(x) = x - 6$

143)  $h(x) = |8x + 4|$  143) \_\_\_\_\_  
 A)  $f(x) = x$ ,  $g(x) = 8x + 4$                       B)  $f(x) = |x|$ ,  $g(x) = 8x + 4$   
 C)  $f(x) = -|x|$ ,  $g(x) = 8x + 4$                       D)  $f(x) = |-x|$ ,  $g(x) = 8x - 4$

144)  $h(x) = \frac{6}{x^2} + 4$  144) \_\_\_\_\_  
 A)  $f(x) = \frac{6}{x^2}$ ,  $g(x) = 4$                       B)  $f(x) = x + 4$ ,  $g(x) = \frac{6}{x^2}$   
 C)  $f(x) = \frac{1}{x}$ ,  $g(x) = \frac{6}{x} + 4$                       D)  $f(x) = x$ ,  $g(x) = \frac{6}{x} + 4$

145)  $h(x) = \frac{3}{\sqrt{8x+7}}$  145) \_\_\_\_\_  
 A)  $f(x) = \frac{3}{x}$ ,  $g(x) = 8x + 7$                       B)  $f(x) = \sqrt{8x+7}$ ,  $g(x) = 3$



C)  $f(x) = 3, g(x) = \sqrt{8x+7}$

D)  $f(x) = \frac{3}{\sqrt{x}}, g(x) = 8x + 7$

146)  $h(x) = (-8x + 13)^7$

A)  $f(x) = x^7, g(x) = -8x + 13$

C)  $f(x) = (-8x)^7, g(x) = 13$

B)  $f(x) = -8x^7, g(x) = x + 13$

D)  $f(x) = -8x + 13, g(x) = x^7$

146) \_\_\_\_\_

147)  $h(x) = \sqrt{84x^2 + 20}$

A)  $f(x) = 84x^2 + 20, g(x) = \sqrt{x}$

C)  $f(x) = \sqrt{84x^2}, g(x) = \sqrt{20}$

B)  $f(x) = \sqrt{x}, g(x) = 84x^2 + 20$

D)  $f(x) = \sqrt{84x + 20}, g(x) = x^2$

147) \_\_\_\_\_

148)  $h(x) = \sqrt{5 - \sqrt{x-5}}$

A)  $f(x) = \sqrt{5+x}, g(x) = \sqrt{x-5}$

C)  $f(x) = \sqrt{x-5}, g(x) = \sqrt{5-x}$

B)  $f(x) = \sqrt{x-5}, g(x) = \sqrt{x-5}$

D)  $f(x) = \sqrt{5-x}, g(x) = \sqrt{x-5}$

148) \_\_\_\_\_

149)  $h(x) = (x-4)^6 + 4(x-4)^5 - 8(x-4)^3 + 2$

A)  $f(x) = x^6 - 4x^5 + 8x^3 + 2, g(x) = x - 4$

C)  $f(x) = x^6 + x^5 - x^3 + 2, g(x) = x - 4$

B)  $f(x) = x^6 + 4x^5 - 8x^3 + 2, g(x) = x - 4$

D)  $f(x) = x^6 + 4x^5 - 8x^3, g(x) = x - 6$

149) \_\_\_\_\_

**Solve the problem.**

150) A balloon (in the shape of a sphere) is being inflated. The radius is increasing at a rate of 1 cm per second. Find a function,  $r(t)$ , for the radius in terms of  $t$ . Find a function,  $V(r)$ , for the volume of the balloon in terms of  $r$ . Find  $(V \circ r)(t)$ .

150) \_\_\_\_\_

A)  $(V \circ r)(t) = \frac{4\pi t^3}{3}$

B)  $(V \circ r)(t) = \frac{5\pi t^2}{3}$

C)  $(V \circ r)(t) = \frac{4\pi\sqrt{t}}{3}$

D)  $(V \circ r)(t) = \frac{7\pi t^3}{3}$

151) A stone is thrown into a pond. A circular ripple is spreading over the pond in such a way that the radius is increasing at the rate of 4.2 feet per second. Find a function,  $r(t)$ , for the radius in terms of  $t$ . Find a function,  $A(r)$ , for the area of the ripple in terms of  $r$ . Find  $(A \circ r)(t)$ .

151) \_\_\_\_\_

A)  $(A \circ r)(t) = 17.64\pi t^2$

B)  $(A \circ r)(t) = 17.64\pi^2 t$

C)  $(A \circ r)(t) = 8.4\pi t^2$

D)  $(A \circ r)(t) = 4.2\pi t^2$

152) Ken is 6 feet tall and is walking away from a streetlight. The streetlight has its light bulb 14 feet above the ground, and Ken is walking at the rate of 1.6 feet per second. Find a function,  $d(t)$ , which gives the distance Ken is from the streetlight in terms of time. Find a function,  $S(d)$ , which gives the length of Ken's shadow in terms of  $d$ . Then find  $(S \circ d)(t)$ .

152) \_\_\_\_\_

A)  $(S \circ d)(t) = 2.7t$

B)  $(S \circ d)(t) = 0.88t$

C)  $(S \circ d)(t) = 1.2t$

D)  $(S \circ d)(t) = 1.52t$

**Determine if the graph is symmetric with respect to x-axis, y-axis, and/or the origin.**

153)

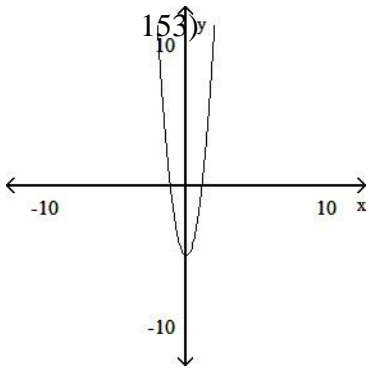

- A) Origin      B) x-axis      C) y-axis      D) x-axis, origin

154)

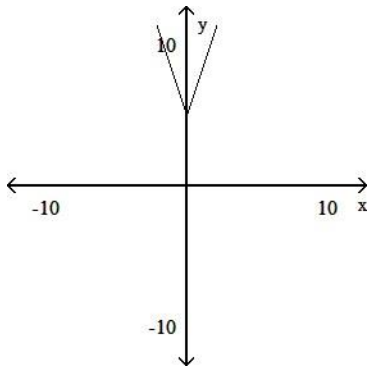

- A) Origin      B) y-axis      C) x-axis, origin      D) x-axis

154) \_\_\_\_\_

155)

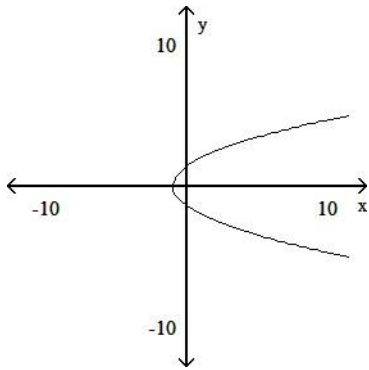

- A) y-axis      B) Origin      C) x-axis, origin      D) x-axis

155) \_\_\_\_\_

156)

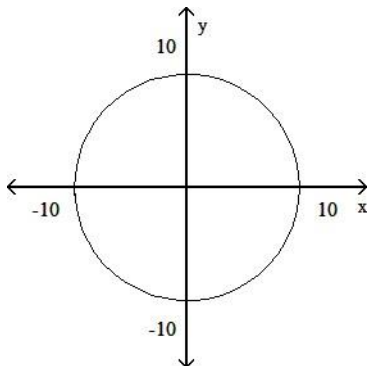

- A) x-axis      B) x-axis, origin  
C) Origin      D) x-axis, y-axis, origin

156) \_\_\_\_\_

157)

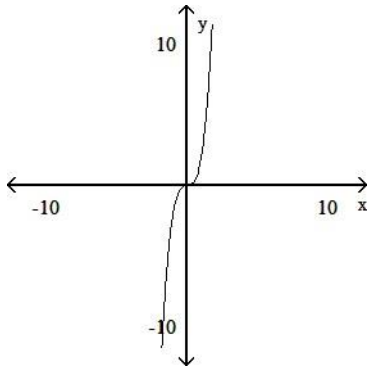

- A) x-axis      B) x-axis, origin      C) y-axis      D) Origin

157) \_\_\_\_\_

158)

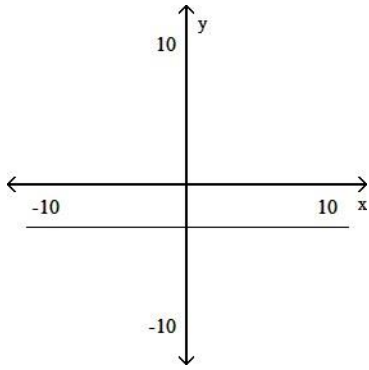

- A) y-axis, origin      B) x-axis, y-axis      C) x-axis      D) y-axis

158) \_\_\_\_\_

159)

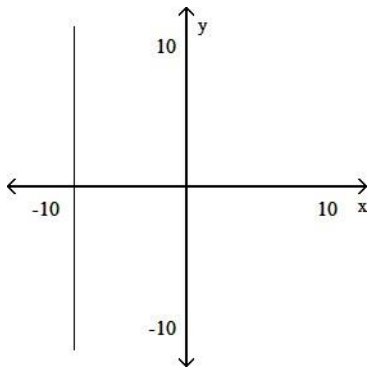

- A) x-axis      B) x-axis, y-axis      C) y-axis      D) no symmetry

159) \_\_\_\_\_

160)

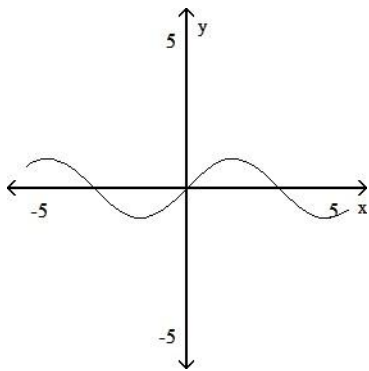

- A) origin      B) y-axis      C) x-axis      D) no symmetry

160) \_\_\_\_\_

Determine algebraically whether the graph is symmetric with respect to the x-axis, the y-axis, and the origin.

- 161)  $y = 2x^2 - 2$  161) \_\_\_\_\_  
A) Origin only B) x-axis only  
C) x-axis, y-axis, origin D) y-axis only
- 162)  $x^2 + 4y^4 = 2$  162) \_\_\_\_\_  
A) Origin only B) y-axis only  
C) x-axis only D) x-axis, y-axis, origin
- 163)  $xy = 1$  163) \_\_\_\_\_  
A) Origin only B) x-axis only  
C) x-axis, y-axis, origin D) y-axis only
- 164)  $3x = 3y^2 + 4$  164) \_\_\_\_\_  
A) Origin only B) x-axis only  
C) x-axis, y-axis, origin D) y-axis only
- 165)  $x^2 + y^2 = 8$  165) \_\_\_\_\_  
A) x-axis only B) y-axis only  
C) x-axis, y-axis, origin D) Origin only
- 166)  $x^2 + xy^2 = 5$  166) \_\_\_\_\_  
A) Origin only B) x-axis, y-axis, origin  
C) y-axis only D) x-axis only
- 167)  $y = (x + 3)(x - 3)$  167) \_\_\_\_\_  
A) x-axis only B) x-axis, y-axis, origin  
C) Origin only D) y-axis only
- 168)  $x^4 + y^4 = 8$  168) \_\_\_\_\_  
A) Origin only B) x-axis only  
C) y-axis only D) x-axis, y-axis, origin
- 169)  $y = |16x|$  169) \_\_\_\_\_  
A) x-axis only B) y-axis only  
C) Origin only D) x-axis, y-axis, origin
- 170)  $11x = |y|$  170) \_\_\_\_\_  
A) Origin only B) y-axis only  
C) x-axis, y-axis, origin D) x-axis only

Find the point that is symmetric to the given point with respect to the requested axis.

- 171) Symmetric with respect to the y-axis 171) \_\_\_\_\_  
(1.5, -1.75)  
A) (-1.75, 1.5) B) (1.5, -1.5) C) (-1.5, -1.75) D) (-1.5, 1.75)
- 172) Symmetric with respect to the y-axis 172) \_\_\_\_\_  
(1.5, 1.75)  
A) (-1.5, 1.75) B) (-1.5, -1.75) C) (1.75, 1.5) D) (1.5, -1.5)

173) Symmetric with respect to the x-axis

$(7, 2)$

A)  $(7, -2)$

B)  $(2, 7)$

C)  $(-7, -2)$

D)  $(-7, 2)$

173) \_\_\_\_\_

174) Symmetric with respect to the origin

$\left(3, \frac{27}{2}\right)$

A)  $\left(-\frac{27}{2}, 3\right)$

B)  $\left(-3, -\frac{27}{2}\right)$

C)  $\left(3, -\frac{27}{2}\right)$

D)  $\left(3, \frac{27}{2}\right)$

174) \_\_\_\_\_

175) Symmetric with respect to the origin

$(-1, 4)$

A)  $(1, -4)$

B)  $(-1, -4)$

C)  $(4, -1)$

D)  $(1, 4)$

175) \_\_\_\_\_

Determine whether the given function is even, odd, or neither even nor odd.

176)

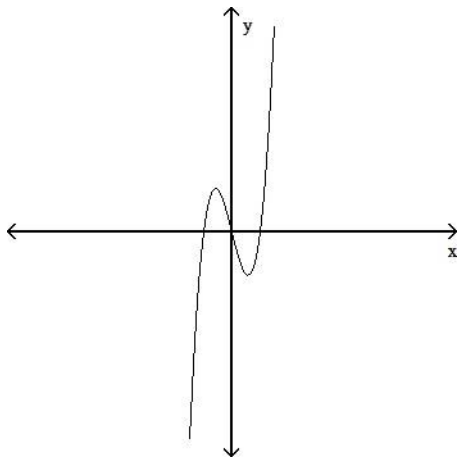

A) Even

B) Odd

C) Neither

176) \_\_\_\_\_

177)

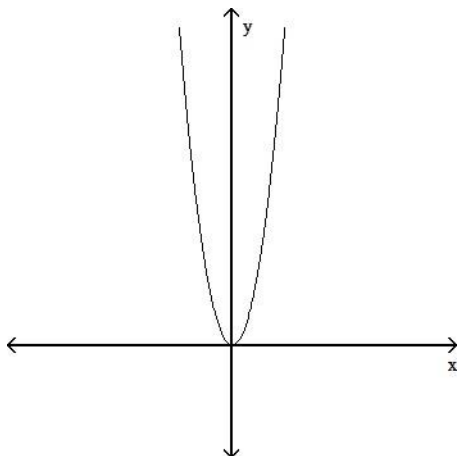

A) Even

B) Neither

C) Odd

177) \_\_\_\_\_

178)

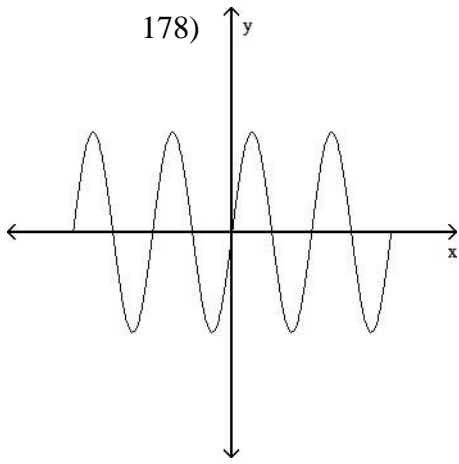

A) Even

B) Neither

C) Odd

\_\_\_\_\_

179)

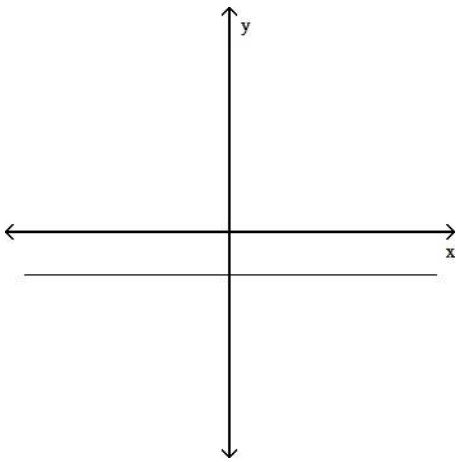

A) Neither

B) Odd

C) Even

179) \_\_\_\_\_

180)

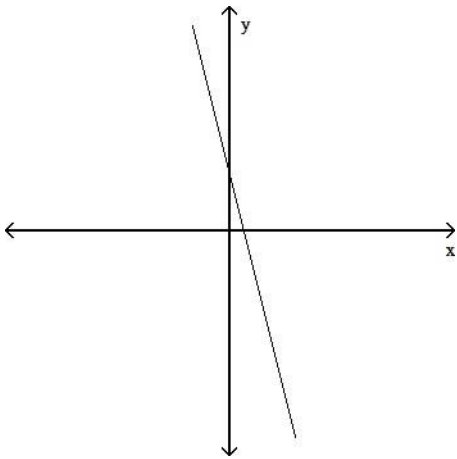

A) Odd

B) Even

C) Neither

180) \_\_\_\_\_

181)

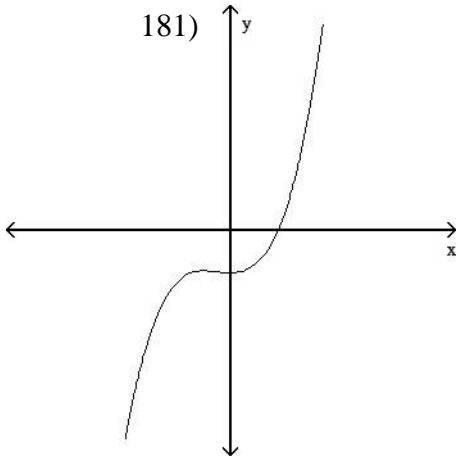

A) Odd

B) Even

C) Neither

\_\_\_\_\_

182)

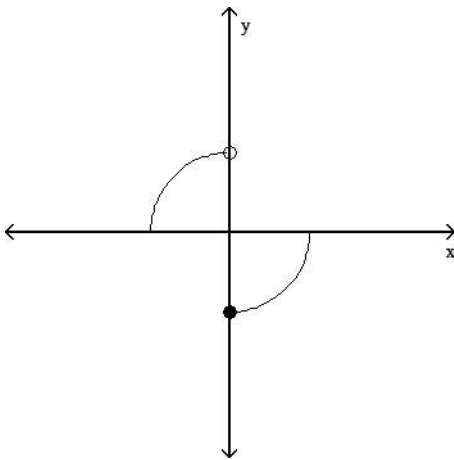

A) Odd

B) Even

C) Neither

182) \_\_\_\_\_

**Determine algebraically whether the function is even, odd, or neither even nor odd.**

183)  $f(x) = 5x^2 + 2$

A) Even

B) Odd

C) Neither

183) \_\_\_\_\_

184)  $f(x) = 5x^5 - 5x^3$

A) Even

B) Odd

C) Neither

184) \_\_\_\_\_

185)  $f(x) = -0.74x^2 + |x| + 7$

A) Even

B) Odd

C) Neither

185) \_\_\_\_\_

186)  $f(x) = 8x^4 - 2x - 5$

A) Even

B) Odd

C) Neither

186) \_\_\_\_\_

187)  $f(x) = x + \frac{14}{x}$

A) Even

B) Odd

C) Neither

187) \_\_\_\_\_

188)  $f(x) = 6\sqrt[3]{x}$

A) Even

B) Odd

C) Neither

188) \_\_\_\_\_

- 189)  $f(x) = \frac{10}{x^2}$  189) \_\_\_\_\_  
 A) Even B) Odd C) Neither
- 190)  $f(x) = 13x - 6|x|$  190) \_\_\_\_\_  
 A) Even B) Odd C) Neither
- 191)  $f(x) = 1$  191) \_\_\_\_\_  
 A) Even B) Odd C) Neither
- 192)  $f(x) = \sqrt{x^2 + 10}$  192) \_\_\_\_\_  
 A) Even B) Odd C) Neither

**Answer the question.**

- 193) How can the graph of  $f(x) = -4|x|$  be obtained from the graph of  $y = |x|$ ? 193) \_\_\_\_\_  
 A) Stretch it vertically by multiplying each y-coordinate by -4. Reflect it across the y axis.  
 B) Stretch it vertically by multiplying each y-coordinate by 4. Reflect it across the y axis.  
 C) Stretch it vertically by multiplying each y-coordinate by 4. Reflect it across the x axis.  
 D) Stretch it vertically by multiplying each y-coordinate by -4. Reflect it across the x axis.
- 194) How can the graph of  $f(x) = -\sqrt{x+5}$  be obtained from the graph of  $y = \sqrt{x}$ ? 194) \_\_\_\_\_  
 A) Shift it horizontally 5 units to the right. Reflect it across the x-axis.  
 B) Shift it horizontally 5 units to the left. Reflect it across the y-axis.  
 C) Shift it horizontally -5 units to the left. Reflect it across the x-axis.  
 D) Shift it horizontally 5 units to the left. Reflect it across the x-axis.
- 195) How can the graph of  $f(x) = (x-9)^2 - 3$  be obtained from the graph of  $y = x^2$ ? 195) \_\_\_\_\_  
 A) Shift it 9 units horizontally to the right. Shift it 3 units downward.  
 B) Shift it 9 units horizontally to the left. Shift it 3 units upward.  
 C) Shift it 9 units horizontally to the left. Shift it 3 units downward.  
 D) Shift it 3 units horizontally to the right. Shift it 9 units downward.
- 196) How can the graph of  $f(x) = -8x^3 + 1$  be obtained from the graph of  $y = x^3$ ? 196) \_\_\_\_\_  
 A) Stretch it vertically by a factor of 8. Reflect it across the y-axis. Shift it 1 units upward.  
 B) Stretch it horizontally by a factor of -8. Reflect it across the x-axis. Shift it 1 units downward.  
 C) Stretch it vertically by a factor of 8. Reflect it across the x-axis. Shift it 1 units upward.  
 D) Stretch it horizontally by a factor of 1. Reflect it across the x-axis. Shift it 8 units upward.
- 197) How can the graph of  $f(x) = 0.9|x - 10| + 1.1$  be obtained from the graph of  $y = |x|$ ? 197) \_\_\_\_\_  
 A) Shift it horizontally 10 units to the right. Shrink it vertically by a factor of 0.9. Shift it 1.1 units upward.  
 B) Shift it horizontally 9 units to the left. Shrink it vertically by a factor of 0.10. Shift it 1.1 units upward.  
 C) Shift it horizontally 10 units to the left. Stretch it vertically by a factor of 9. Shift it 1.1 units upward.  
 D) Shift it horizontally 1.1 units to the right. Stretch it vertically by a factor of 9. Shift it 10 units downward.



- 198) How can the graph of  $y = 0.6\sqrt[3]{-x}$  be obtained from the graph of  $y = \sqrt[3]{x}$  \_\_\_\_\_
- A) Reflect it across the x-axis. Stretch it vertically by a factor of 6.  
 B) Reflect it across the y-axis. Shrink it vertically by a factor of 0.6.  
 C) Reflect it across the x-axis. Shrink it vertically by a factor of 0.6.  
 D) Reflect it across the y-axis. Stretch it vertically by a factor of 6.
- 199) How can the graph of  $f(x) = 0.5|x| - 10$  be obtained from the graph of  $y = |x|$ ? \_\_\_\_\_
- A) Reflect it across the x-axis. Stretch it horizontally by a factor of 10. Shift it horizontally 5 units to the left.  
 B) Reflect it across the y-axis. Shrink it vertically by a factor of 0.5. Shift it vertically 10 units upward.  
 C) Reflect it across the y-axis. Shrink it vertically by a factor of 0.5. Shift it vertically 10 units downward.  
 D) Reflect it across the x-axis. Stretch it vertically by a factor of 5. Shift it horizontally 10 units to the right.
- 200) How can the graph of  $f(x) = \frac{1}{2}(x+3)^2 - 10$  be obtained from the graph of  $y = x^2$ ? \_\_\_\_\_
- A) Shift it horizontally 3 units to the left. Shrink it vertically by a factor of  $\frac{1}{2}$ . Shift it 10 units down.  
 B) Shift it horizontally 3 units to the left. Shrink it vertically by a factor of 2. Shift it 10 units down.  
 C) Shift it horizontally 3 units to the right. Stretch it vertically by a factor of 2. Shift it 10 units up.  
 D) Shift it horizontally 3 units to the right. Shrink it vertically by a factor of  $\frac{1}{2}$ . Shift it 10 units down.
- 201) How can the graph of  $f(x) = \frac{6}{x} + 11$  be obtained from the graph of  $y = \frac{1}{x}$ ? \_\_\_\_\_
- A) Shift it horizontally 6 units to the right. Shift it 11 units up.  
 B) Shrink it vertically a factor of  $\frac{1}{6}$ . Shift it 11 units up.  
 C) Shift it horizontally 6 units to the left. Shift it 11 units down.  
 D) Stretch it vertically by a factor of 6. Shift it 11 units up.
- 202) How can the graph of  $f(x) = \frac{1}{x+3} - 2$  be obtained from the graph of  $y = \frac{1}{x}$ ? \_\_\_\_\_
- A) Shift it horizontally 3 units to the left. Shift it 2 units down.  
 B) Shrink it horizontally by a factor of  $\frac{1}{2}$ . Shift it 2 units down.  
 C) Shift it horizontally 3 units to the left. Shift it 2 units up.  
 D) Shift it horizontally 3 units to the right. Stretch it vertically by a factor of 2.
- 203) How can the graph of  $f(x) = \frac{1}{-x} - 11$  be obtained from the graph of  $y = \frac{1}{x}$ ? \_\_\_\_\_
- A) Reflect it across the x-axis. Shift it 11 units down.  
 B) Reflect it across the x-axis. Shift it 11 units up.  
 C) Reflect it across the y-axis. Shift it 11 units down.

D) Reflect it across the y-axis. Shift it 11 units up.

204) How can the graph of  $f(x) = -\frac{1}{x} + 1$  be obtained from the graph of  $y = \frac{1}{x}$ ?

204) \_\_\_\_\_

- A) Reflect it across the x-axis. Shift it 1 units up.
- B) Reflect it across the y-axis. Shift it 1 units up.
- C) Reflect it across the x-axis. Shift it 1 units down.
- D) Reflect it across the y-axis. Shift it 1 units down.

205) How can the graph of  $f(x) = -(x - 10)^2 + 4$  be obtained from the graph of  $y = x^2$ ?

205) \_\_\_\_\_

- A) Shift it horizontally 10 units to the right. Reflect it across the y-axis. Shift it 4 units up.
- B) Shift it horizontally 10 units to the right. Reflect it across the y-axis. Shift it 4 units down.
- C) Shift it horizontally 10 units to the right. Reflect it across the x-axis. Shift it 4 units up.
- D) Shift it horizontally 10 units to the left. Reflect it across the x-axis. Shift it 4 units up.

206) How can the graph of  $f(x) = 0.6(x + 7)^2 - 3$  be obtained from the graph of  $y = x^2$ ?

206) \_\_\_\_\_

- A) Shift it horizontally 7 units to the right. Shrink it vertically by a factor of 0.6. Shift it 3 units up.
- B) Shift it horizontally 3 units to the left. Stretch it vertically by a factor of 12. Shift it 7 units down.
- C) Shift it horizontally 7 units to the left. Shrink it vertically by a factor of 0.6. Shift it 3 units down.
- D) Shift it horizontally 7 units to the left. Shrink it horizontally by a factor of 0.6. Shift it 3 units down.

**Graph the basic function using a solid line and the transformed function using a dotted line.**

207)  $f(x) = x^2 - 3$

207) \_\_\_\_\_

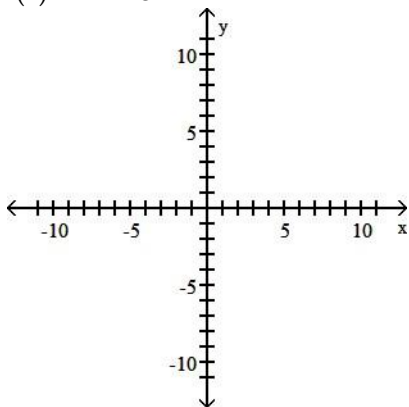

A)

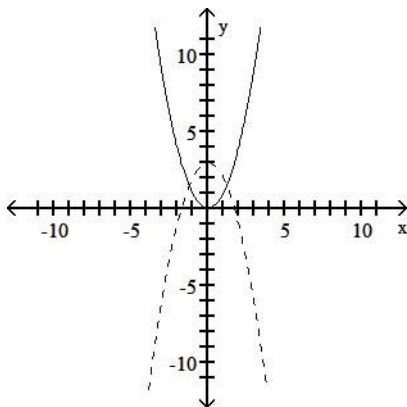

B)

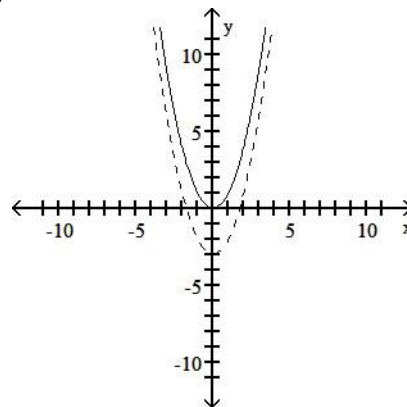

C)

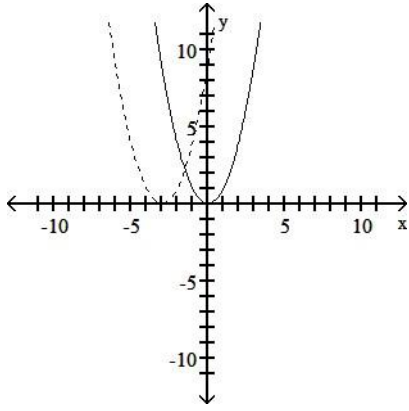

D)

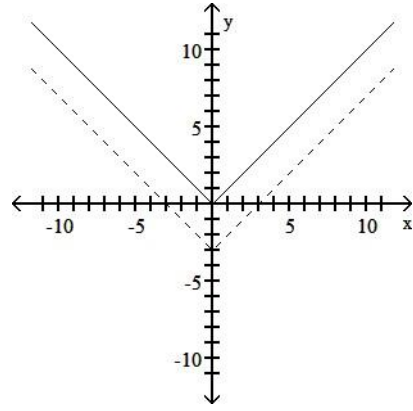

208)  $f(x) = |x - 2|$

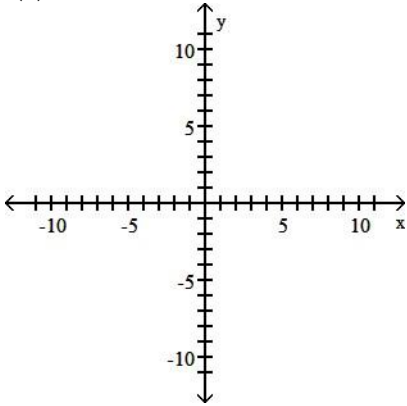

208) \_\_\_\_\_

A)

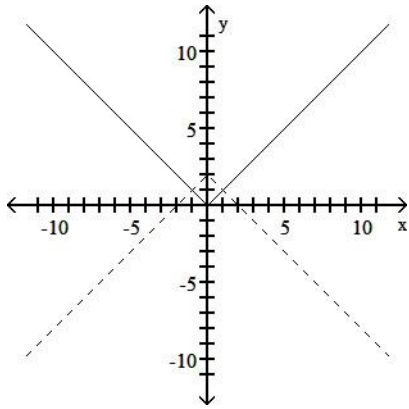

B)

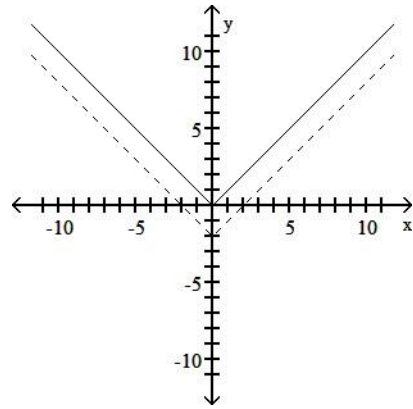

C)

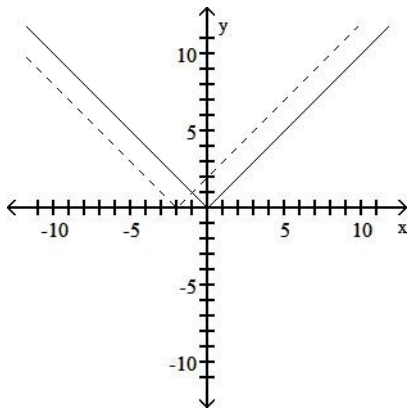

D)

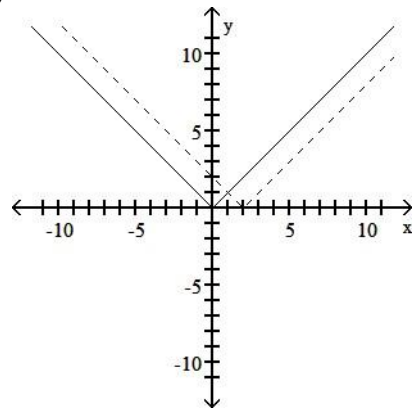

209)  $g(x) = -3|x|$

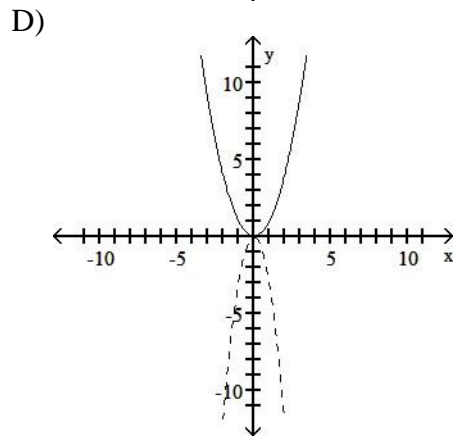
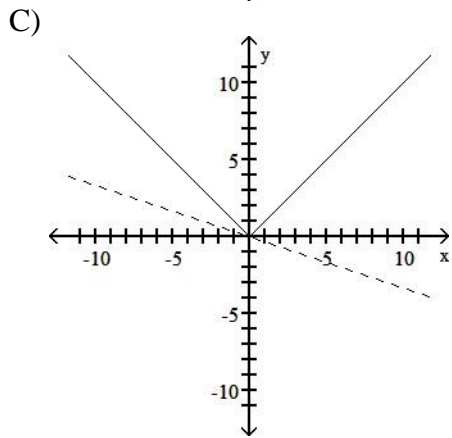
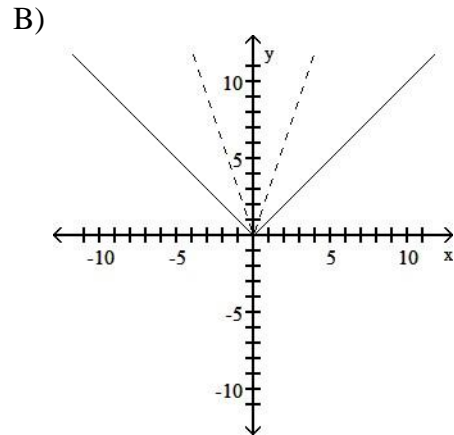
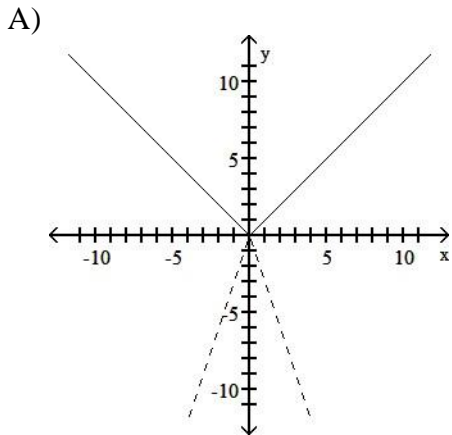
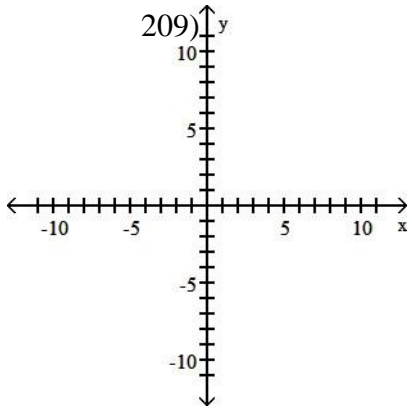

210)  $h(x) = (x - 3)^2 - 2$

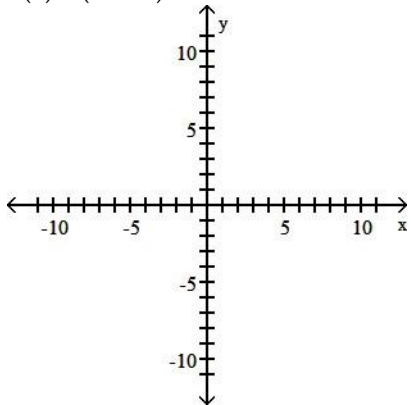

A)

210) \_\_\_\_\_

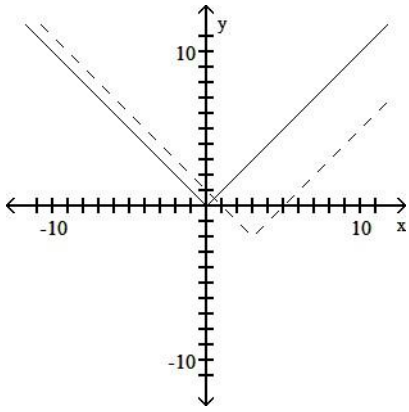

B)

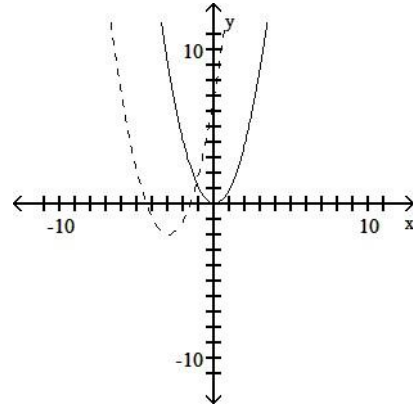

C)

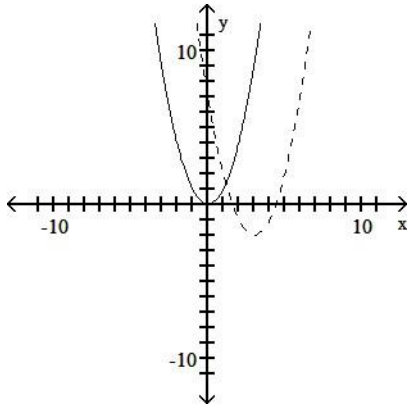

D)

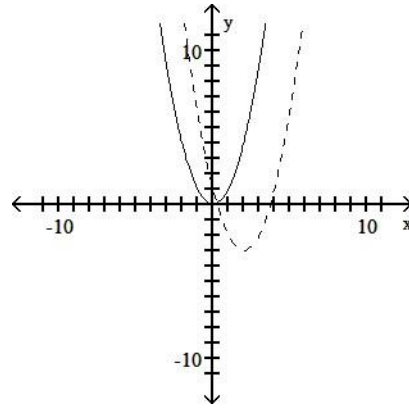

211)  $f(x) = -\frac{1}{4}(x + 4)^2 + 3$

211) \_\_\_\_\_

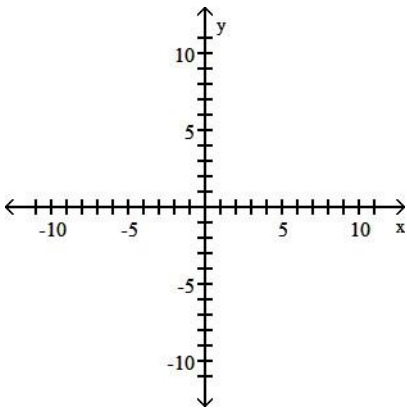

A)

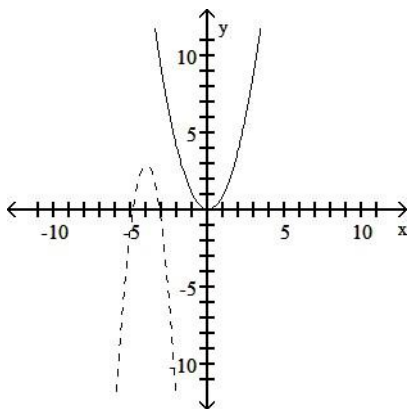

B)

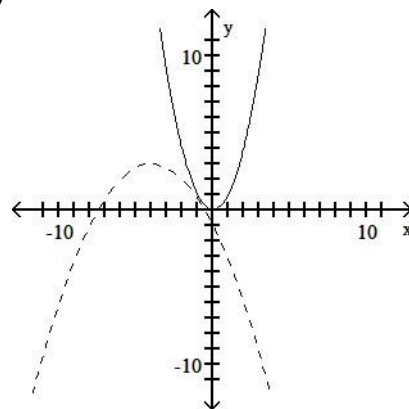

C)

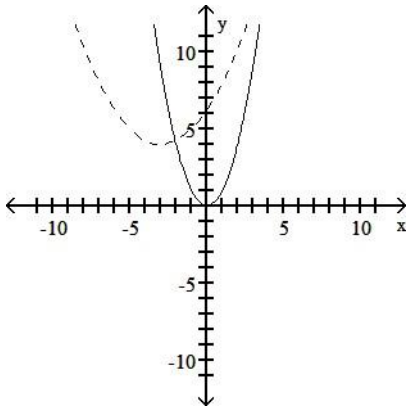

D)

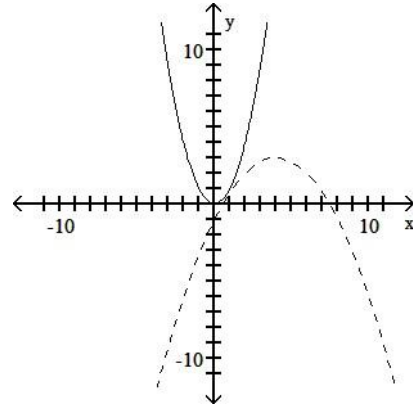

212)  $h(x) = \frac{1}{4}|x + 4| - 6$

212) —

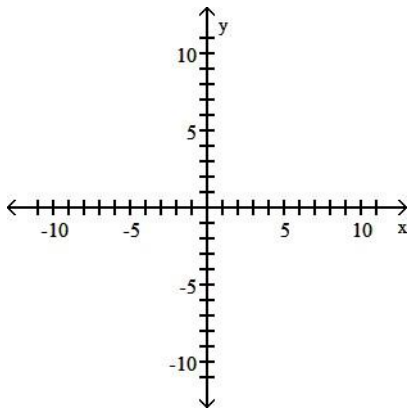

A)

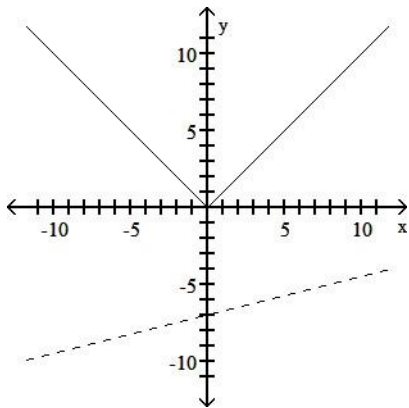

B)

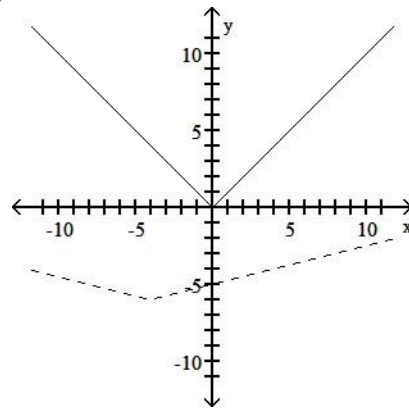

C)

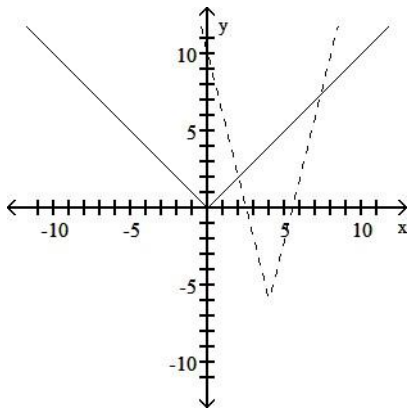

D)

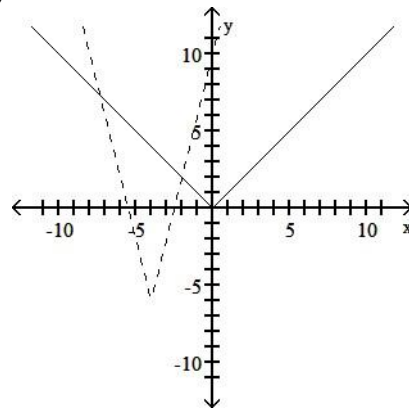

213)  $g(x) = (x + 2)^3$

213) \_\_\_\_\_

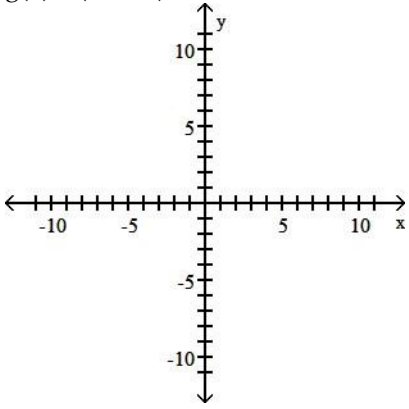

A)

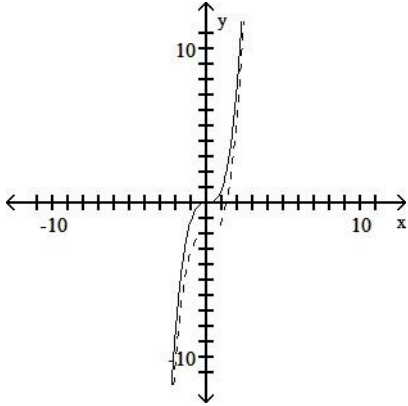

B)

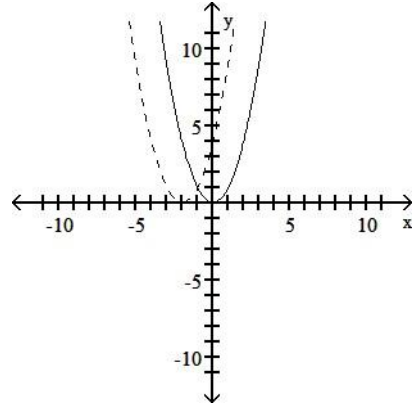

C)

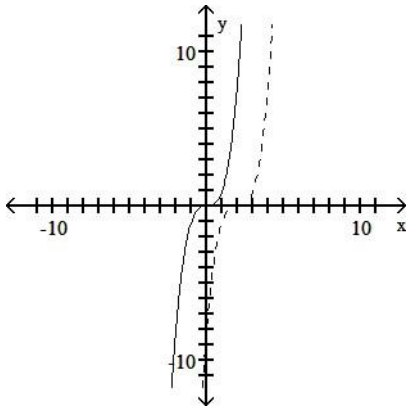

D)

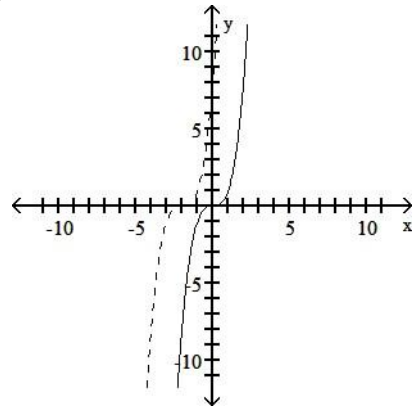

214)  $g(x) = \sqrt[3]{x} + 3$

214) \_\_\_\_\_

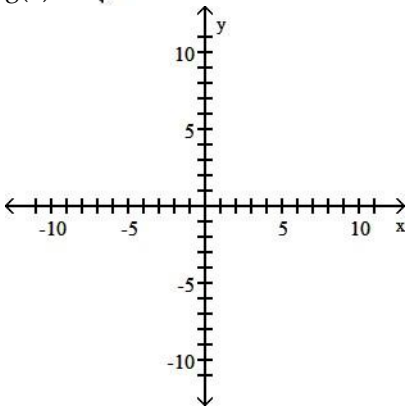

A)

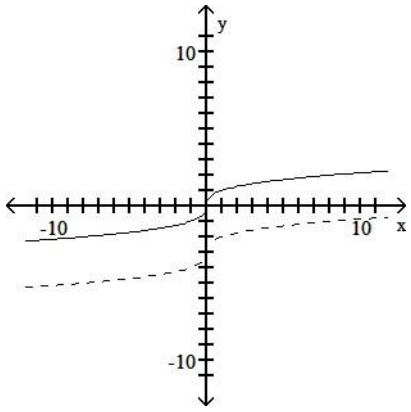

B)

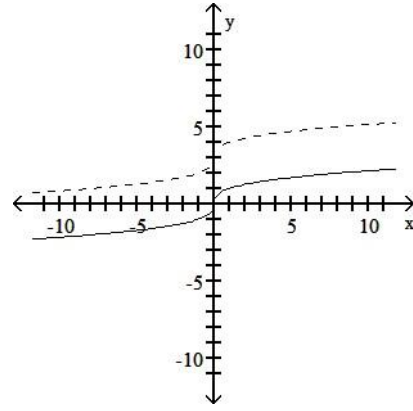

C)

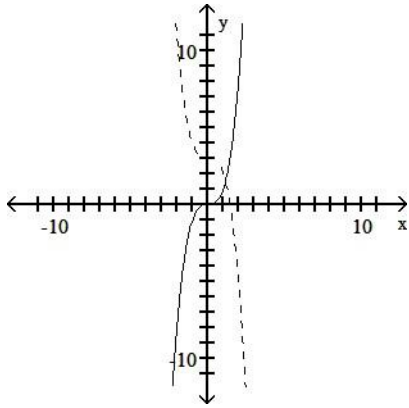

D)

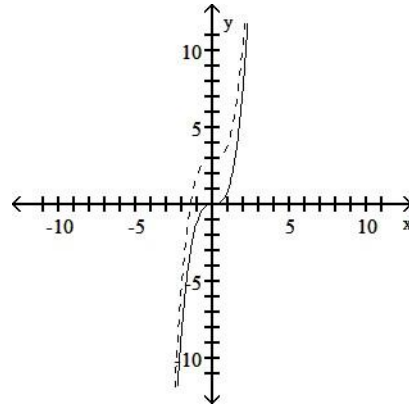

215)  $f(x) = \sqrt{x+2}$

215) \_\_\_\_\_

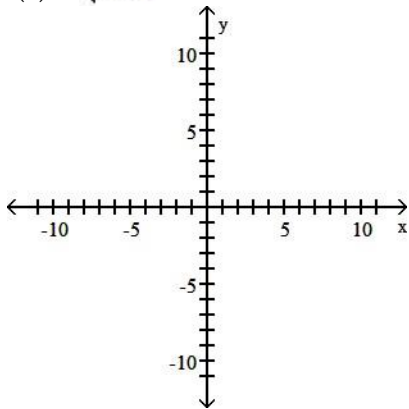

A)

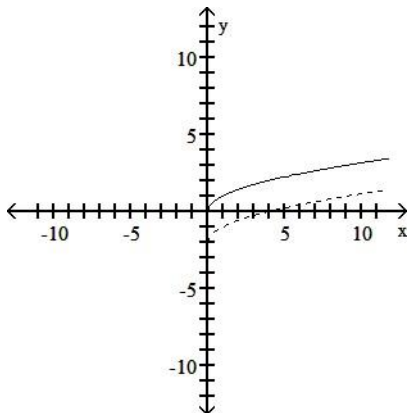

B)

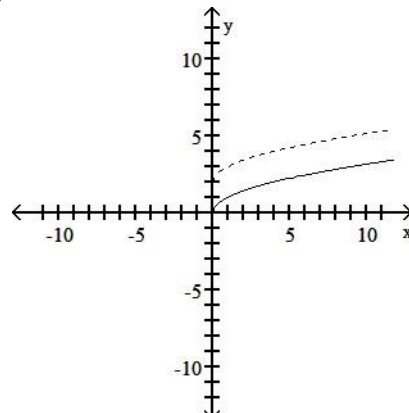

C)



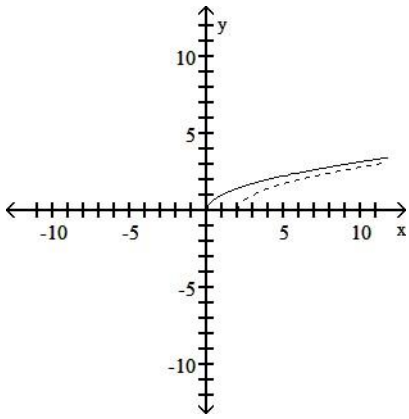

D)

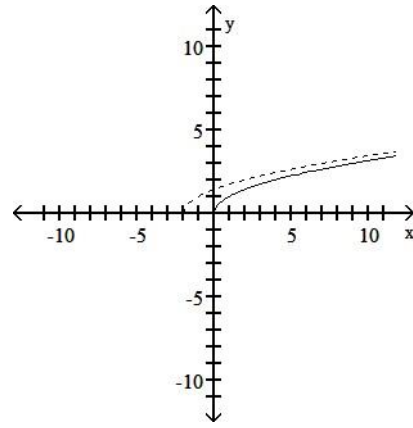

216)  $f(x) = (x + 3)^3 + 3$

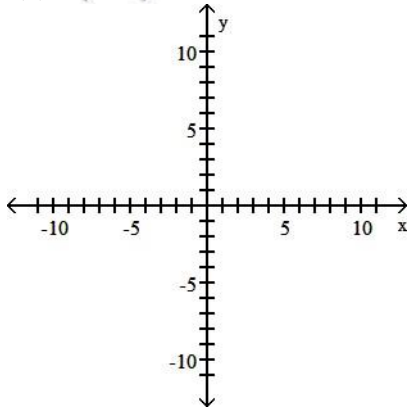

216) \_\_\_\_\_

A)

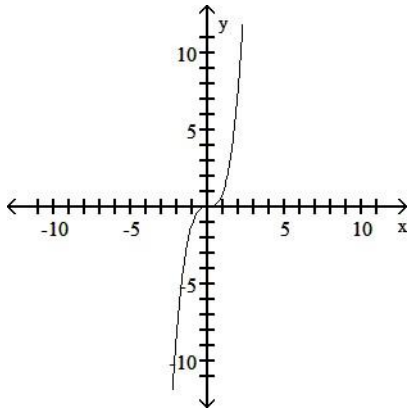

B)

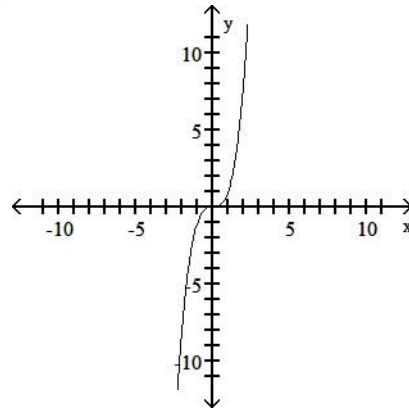

C)

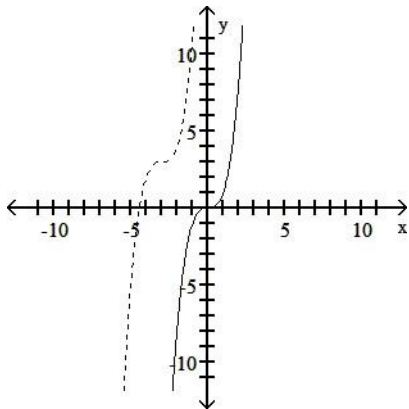

D)

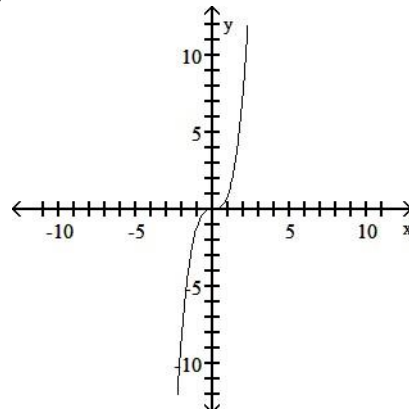

The given point is on the graph of  $y = f(x)$ . Find a point on the graph of  $y = g(x)$ .

- 217)  $g(x) = f(x) + 3$ ; (4, 14) 217) \_\_\_\_\_  
 A) (4, 17) B) (4, 15) C) (4, 18) D) (4, 21)
- 218)  $g(x) = f(x) - 3$ ; (2, 8) 218) \_\_\_\_\_  
 A) (2, 6) B) (2, 3) C) (2, 5) D) (2, 9)
- 219)  $g(x) = f(x - 1)$ ; (7, 18) 219) \_\_\_\_\_  
 A) (8, 18) B) (7, 17) C) (6, 18) D) (7, 19)
- 220)  $g(x) = f(x + 1)$ ; (7, 18) 220) \_\_\_\_\_  
 A) (7, 17) B) (7, 19) C) (8, 18) D) (6, 18)
- 221)  $g(x) = f(x - 1) + 3$ ; (4, 13) 221) \_\_\_\_\_  
 A) (14, 10) B) (14, 16) C) (5, 10) D) (5, 16)
- 222)  $g(x) = \frac{1}{2}f(x)$ ; (-2, 8) 222) \_\_\_\_\_  
 A) (-2, -4) B) (-1, -4) C) (1, 4) D) (-2, 4)
- 223)  $g(x) = f\left[-\frac{1}{2}x\right]$ ; (3, -2) 223) \_\_\_\_\_  
 A)  $\left[-\frac{3}{2}, -3\right]$  B) (6, 2) C) (-6, -2) D)  $\left[\frac{1}{6}, -3\right]$
- 224)  $g(x) = 2f(x)$ ; (2, 4) 224) \_\_\_\_\_  
 A) (2, 8) B) (4, 4) C) (5, 1) D) (1, 4)
- 225)  $g(x) = f(-8x)$ ; (3, -8) 225) \_\_\_\_\_  
 A) (-24, -8) B)  $\left[-\frac{3}{8}, -8\right]$  C) (24, 8) D)  $\left[\frac{1}{24}, -3\right]$

Given the function  $f$ , match the function  $g$  with a transformation of  $f$ .

- 226)  $f(x) = x^2 - 7$ ,  $g(x) = (x - 4)^2 - 7$  226) \_\_\_\_\_  
 A)  $f(x) - 4$  B)  $f(x) + 4$  C)  $f(x + 4)$  D)  $f(x - 4)$
- 227)  $f(x) = x^2 - 6$ ,  $g(x) = x^2 - 3$  227) \_\_\_\_\_  
 A)  $f(x) + 3$  B)  $f(x + 3)$  C)  $f(x - 3)$  D)  $f(x) - 3$
- 228)  $f(x) = x^2 - 5$ ,  $g(x) = 4x^2 - 20$  228) \_\_\_\_\_  
 A)  $f(x) + 4$  B)  $4f(x)$  C)  $f(4x)$  D)  $f(x + 4)$
- 229)  $f(x) = x^2 - 3$ ,  $g(x) = 16x^2 - 3$  229) \_\_\_\_\_  
 A)  $4f(x)$  B)  $f(4x)$  C)  $f(x) + 4$  D)  $f(x + 4)$

Write an equation for a function that has a graph with the given characteristics.

- 230) The shape of  $y = x^2$ , but upside-down and vertically stretched by a factor of 7. 230) \_\_\_\_\_  
 A)  $f(x) = 7(x - 7)x^2$  B)  $f(x) = 7x^2$   
 C)  $f(x) = (x - 7)^2$  D)  $f(x) = -7x^2$

231) The shape of  $y = x^3$  is shifted 5.3 units to the right and then vertically shrunk by a factor of 0.6. 231) \_\_\_\_\_

A)  $f(x) = 0.6(x + 5.3)^3$

B)  $f(x) = 0.6x^3 + 5.3$

C)  $f(x) = 5.3(x - 0.6)^3$

D)  $f(x) = 0.6(x - 5.3)^3$

232) The shape of  $y = |x|$  is vertically stretched by a factor of 3.9. This graph is then reflected across the x-axis. Finally, the graph is shifted 0.59 units downward. 232) \_\_\_\_\_

A)  $f(x) = 3.9|-x| - 0.59$

B)  $f(x) = 3.9|x| - 0.59|$

C)  $f(x) = -3.9|x| - 0.59$

D)  $f(x) = 3.9|x| - 0.59$

233) The shape of  $y = \sqrt[3]{x}$  is shifted 7.9 units to the left. This graph is then vertically stretched by a factor of 1.9. Finally, the graph is reflected across the x-axis. 233) \_\_\_\_\_

A)  $f(x) = 1.9\sqrt[3]{x+7.9}$

B)  $f(x) = -7.9\sqrt[3]{x+1.9}$

C)  $f(x) = -1.9\sqrt[3]{x-7.9}$

D)  $f(x) = -1.9\sqrt[3]{x+7.9}$

234) The shape of  $y = \sqrt{x}$  is shifted 2 units to the left. Then the graph is shifted 6 units upward. 234) \_\_\_\_\_

A)  $f(x) = \sqrt{x+6} + 2$

B)  $f(x) = \sqrt{x-2} + 6$

C)  $f(x) = \sqrt{x+2} + 6$

D)  $f(x) = 6\sqrt{x+2}$

235) The shape of  $y = |x|$  is reflected across the y-axis. This graph is then vertically stretched by a factor of 3.1. Finally, the graph is shifted 2 units downward. 235) \_\_\_\_\_

A)  $f(x) = -3.1|x| - 2$

B)  $f(x) = 2|-x| - 3.1$

C)  $f(x) = 3.1|-x| + 2$

D)  $f(x) = 3.1|-x| - 2$

**A graph of  $y = f(x)$  follows. No formula for  $f$  is given. Graph the given equation.**

236)  $y = 2f(x)$

236) \_\_\_\_\_

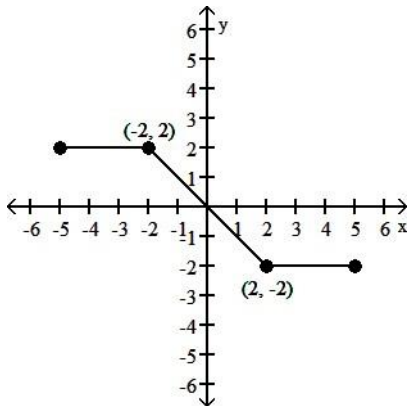

A)

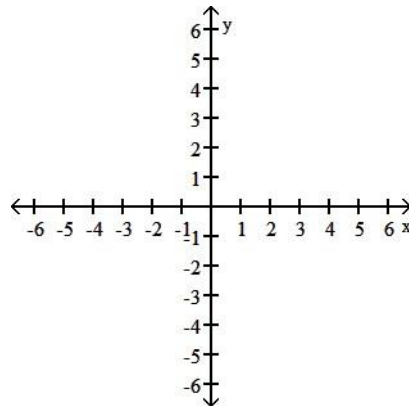

B)

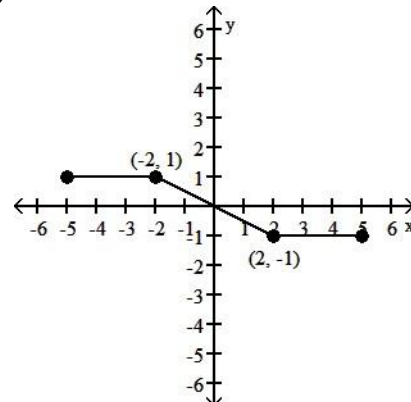
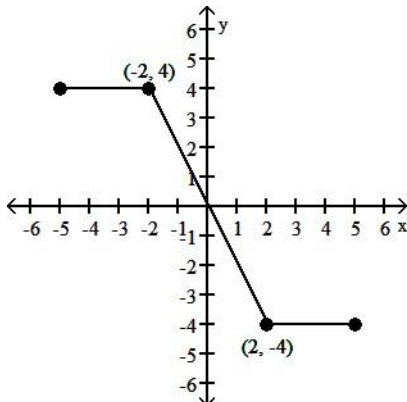

C)

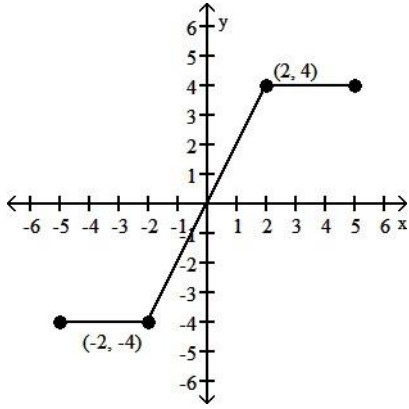

D)

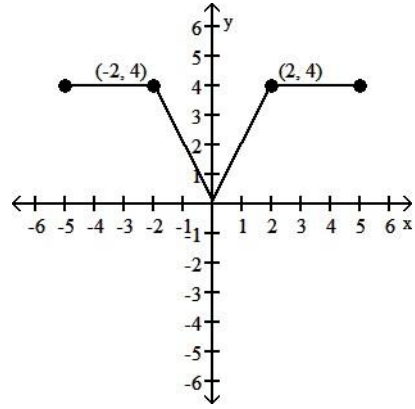

237)  $y = -\frac{1}{2}f(x)$

237) \_\_\_\_\_

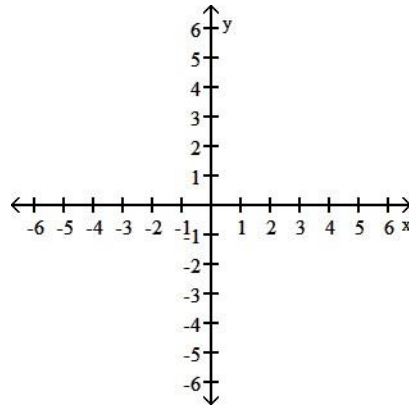
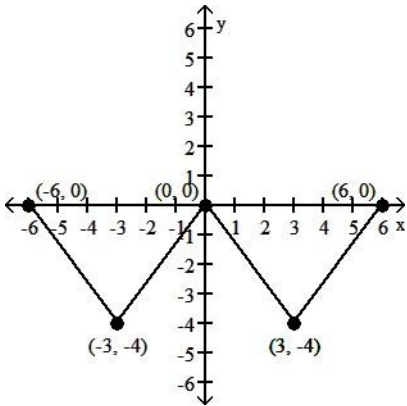

A)

B)

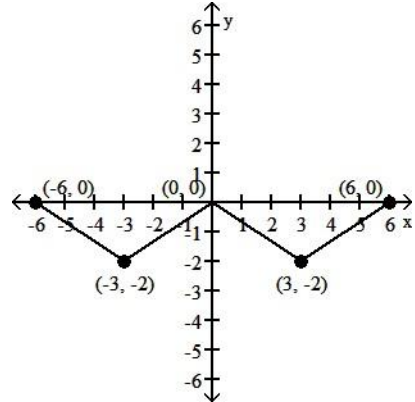
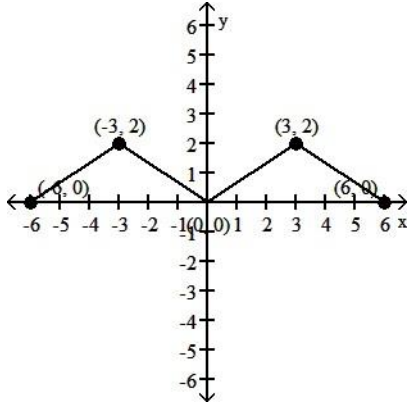

C)

D)

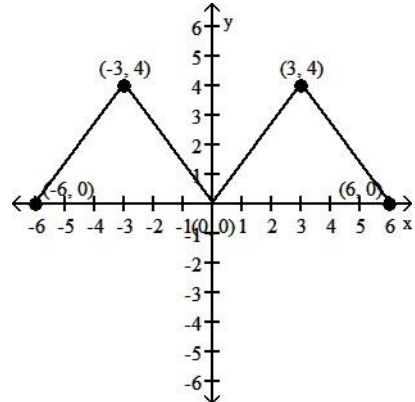
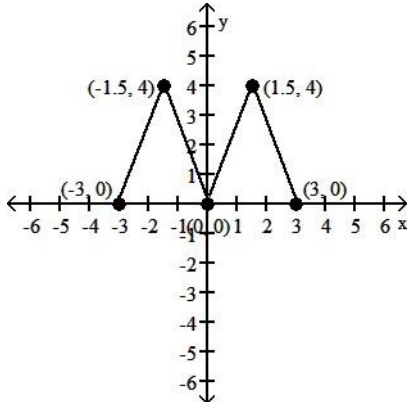

238)  $y = f(2x)$

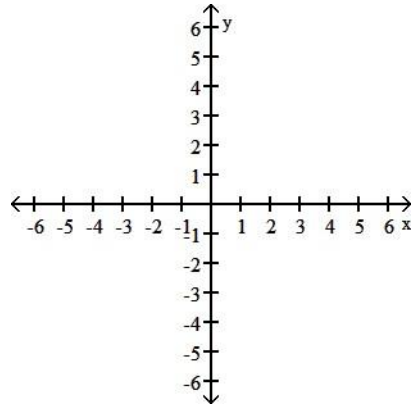
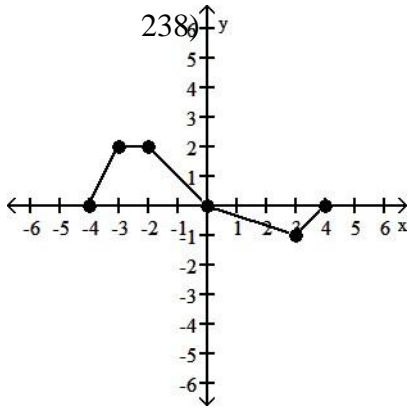

A)

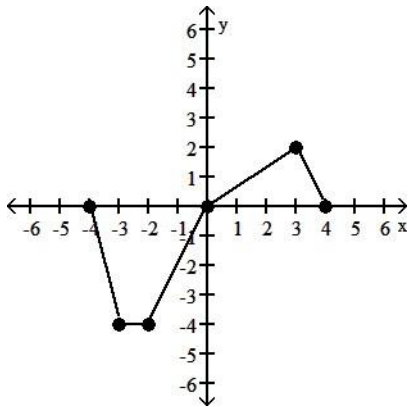

B)

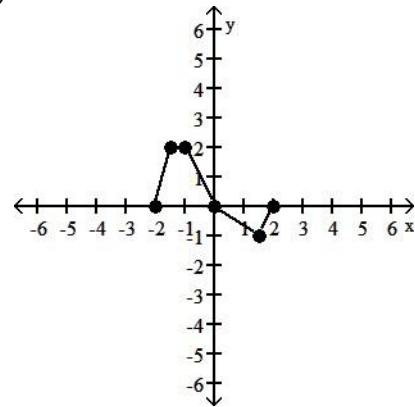

C)

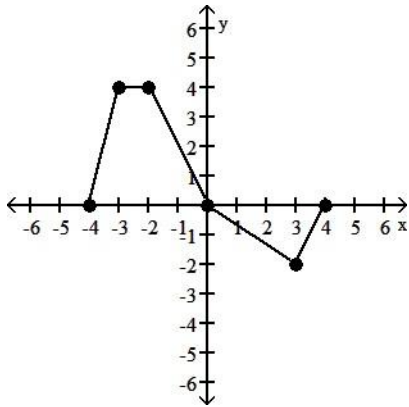

D)

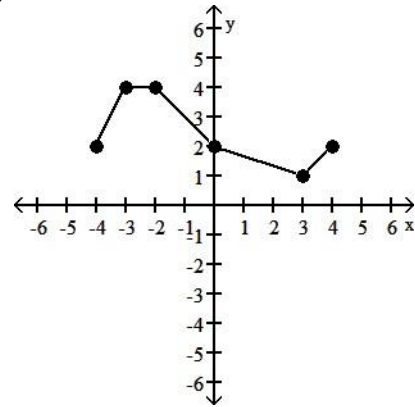

239)  $y = f\left(-\frac{1}{2}x\right)$

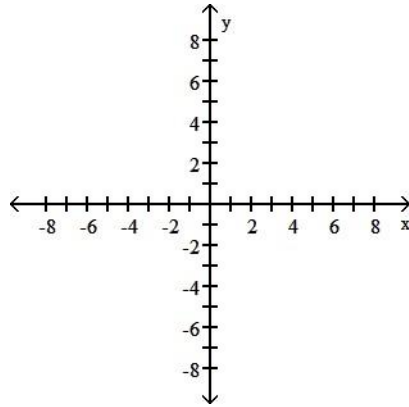
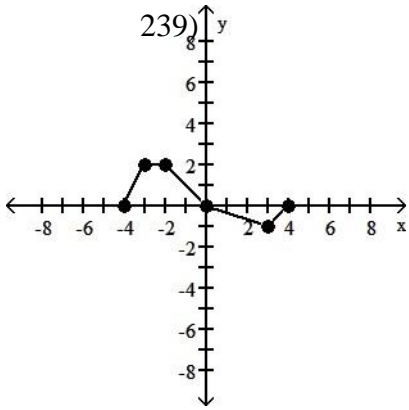

A)

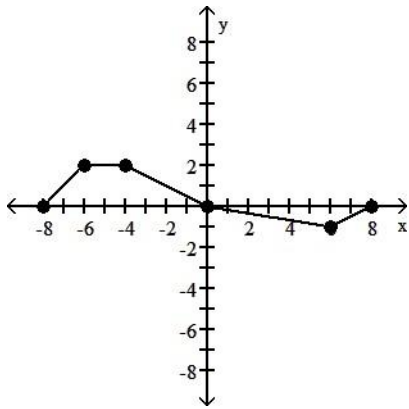

B)

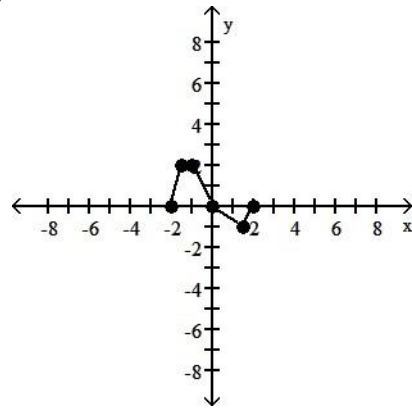

C)

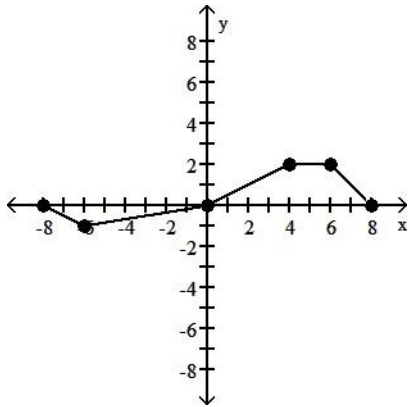

D)

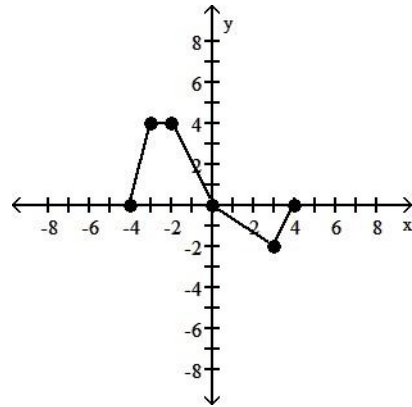

240)  $y = -2f(x + 1) - 3$

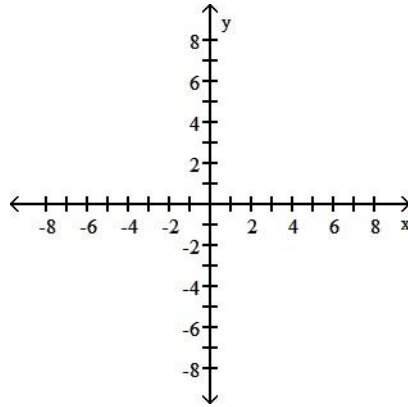
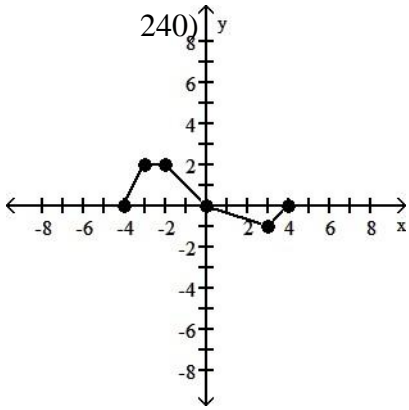

A)

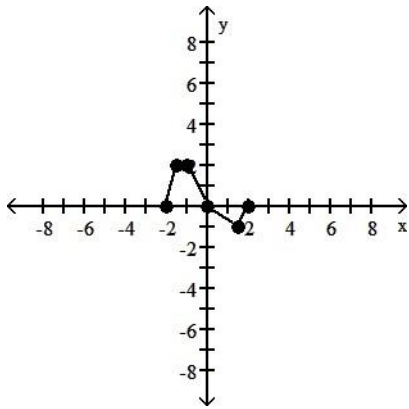

B)

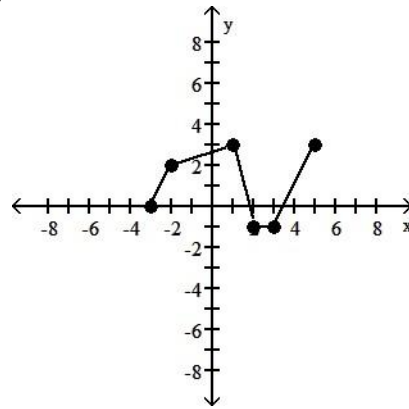

C)

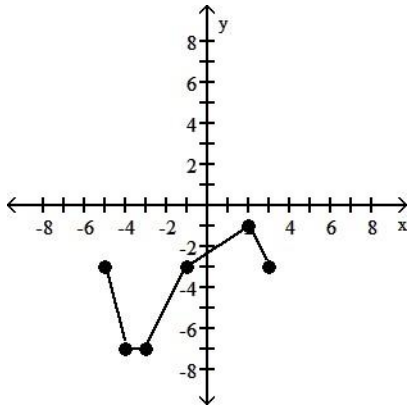

D)

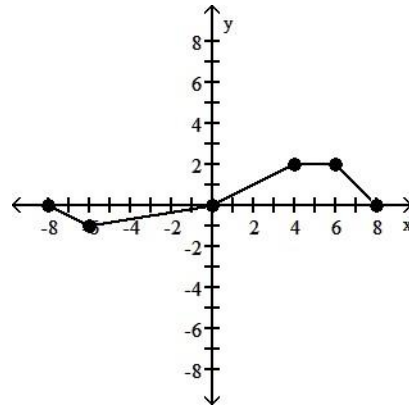

241)  $y = \frac{1}{2}f(x - 1) + 3$

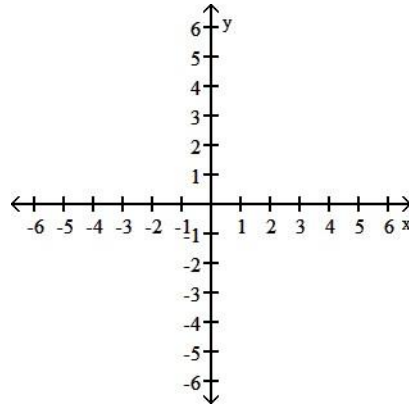
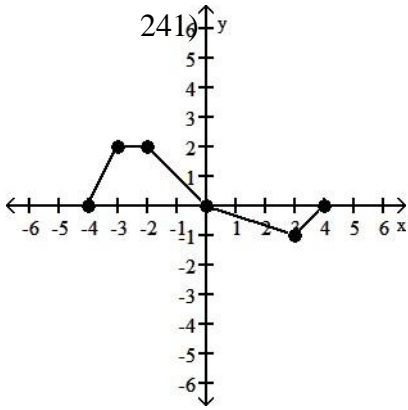

A)

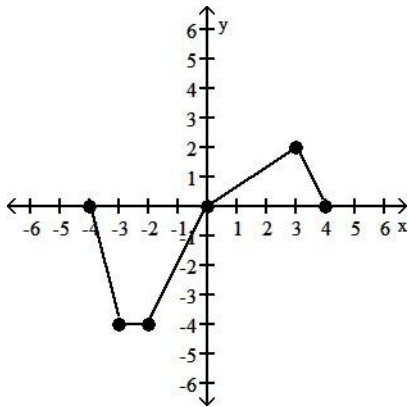

B)

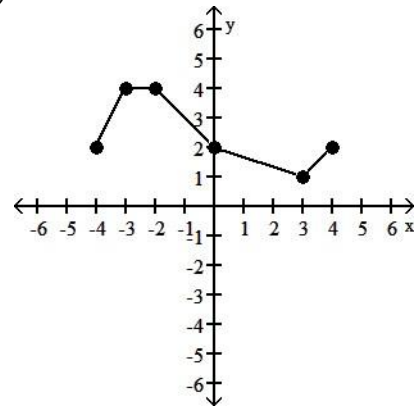

C)

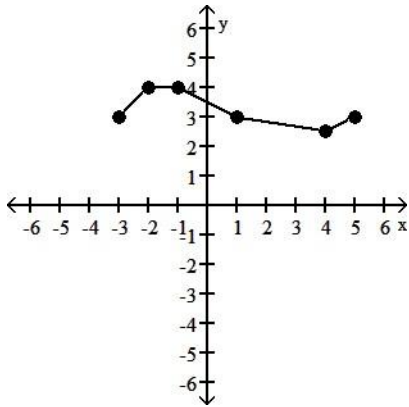

D)

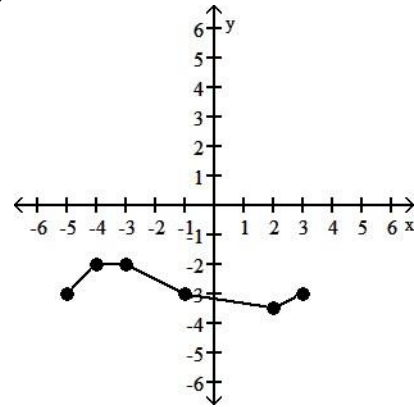

The graph of the function  $f$  is shown below. Match the function  $g$  with the correct graph.

242)  $g(x) = f(x) + 1$



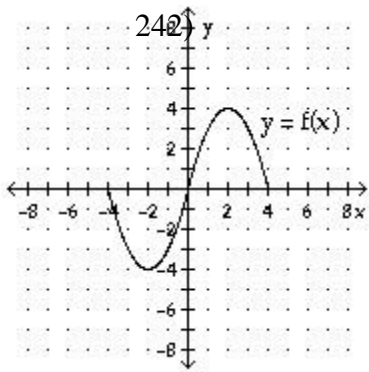

A)

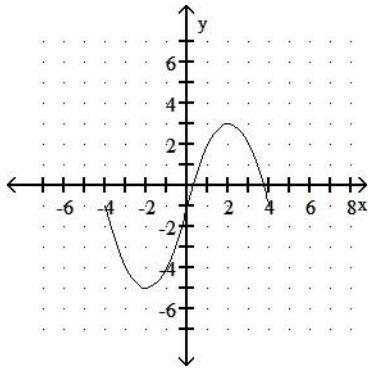

B)

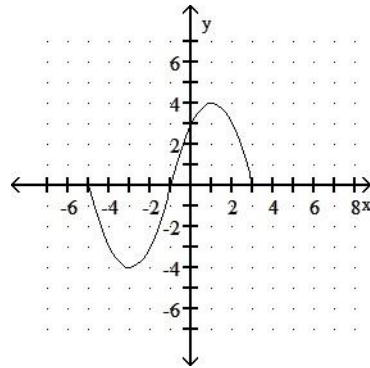

C)

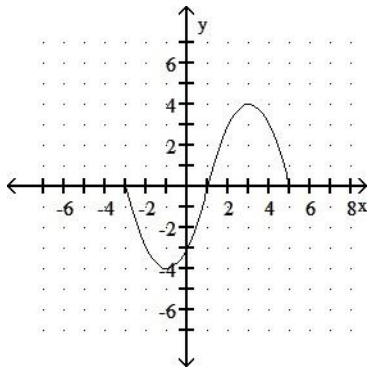

D)

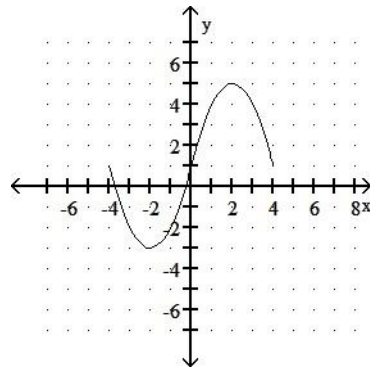

243)  $g(x) = f(x+1)$

243) \_\_\_\_\_

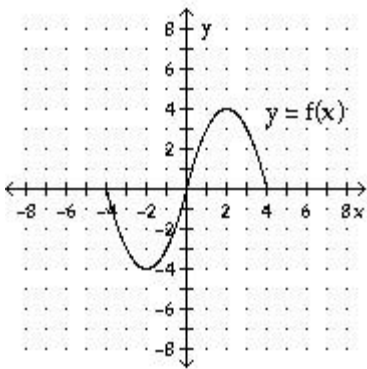

A)

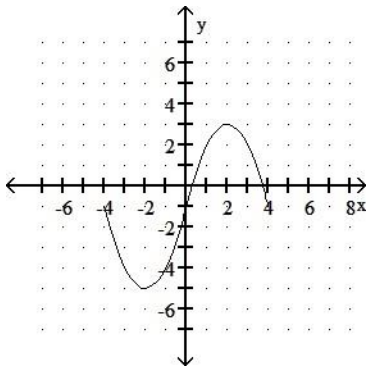

B)

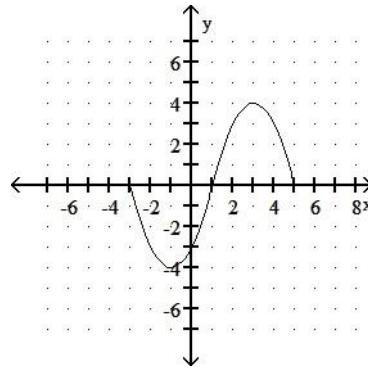

C)

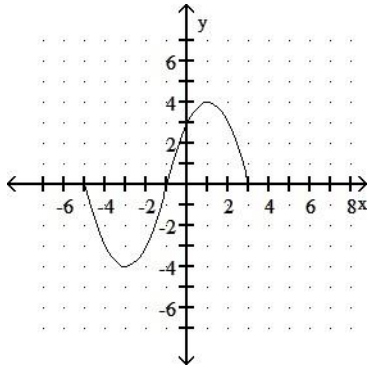

D)

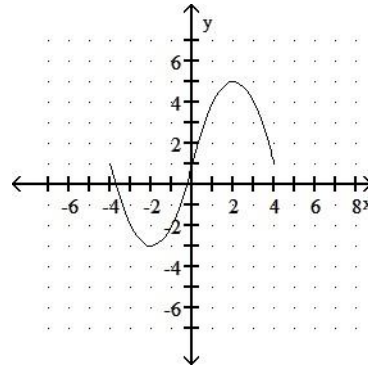

244)  $g(x) = f(x-2)$

244) \_\_\_\_\_

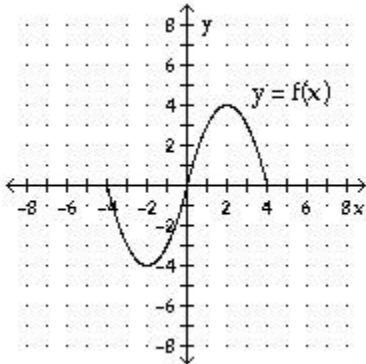

A)

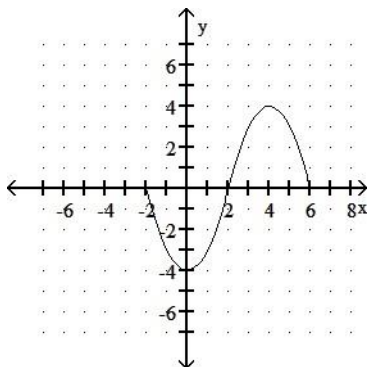

B)

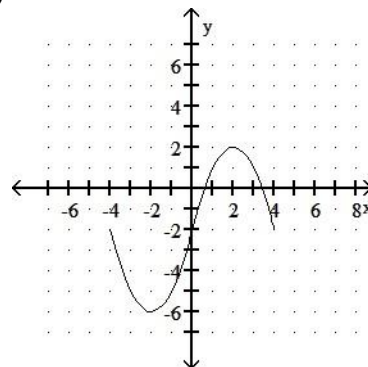

C)

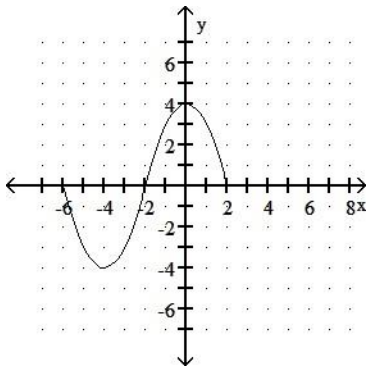

D)

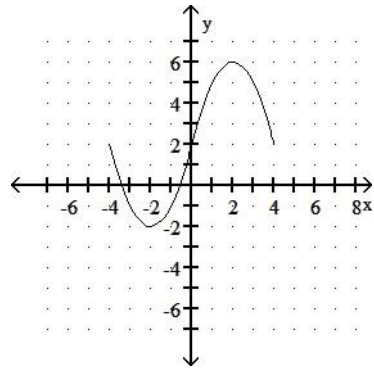

245)  $g(x) = f(x) - 2$

245) \_\_\_\_\_

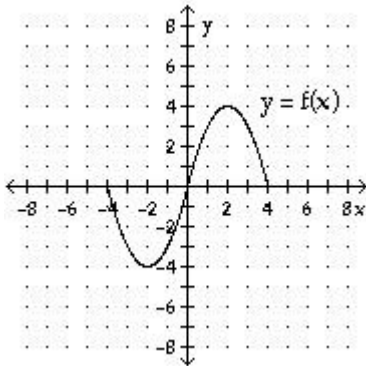

A)

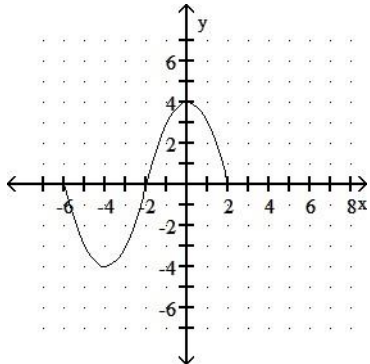

B)

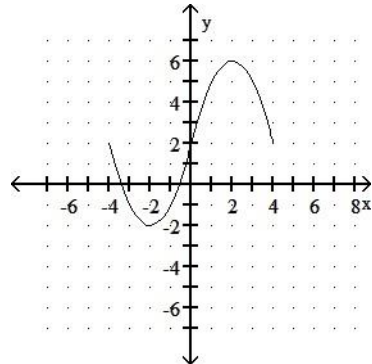

C)

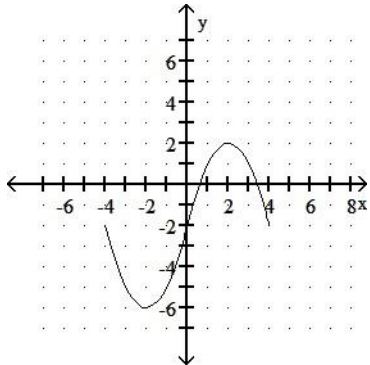

D)

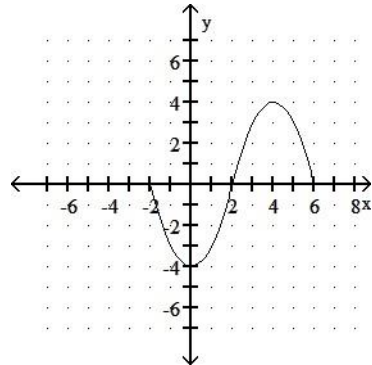

246)  $g(x) = f(-x) + 1$

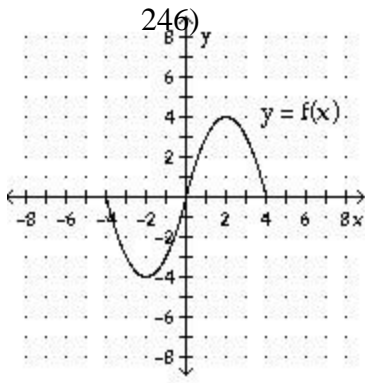

A)

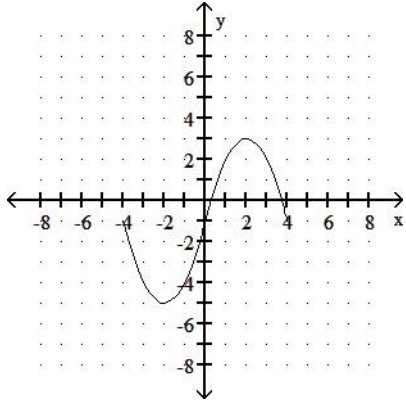

B)

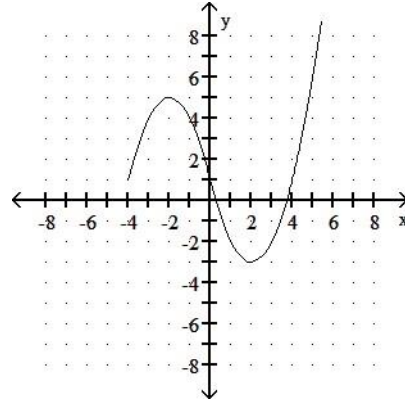

C)

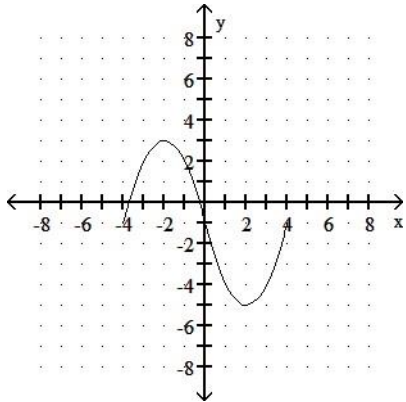

D)

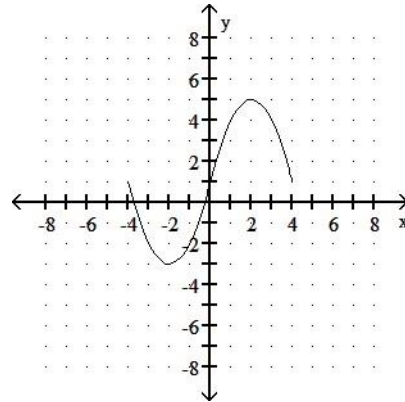

247)  $g(x) = -f(x) - 3$

247) \_\_\_\_\_

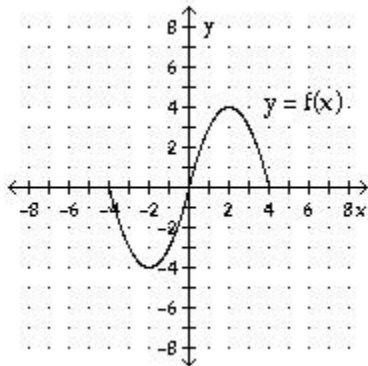

A)

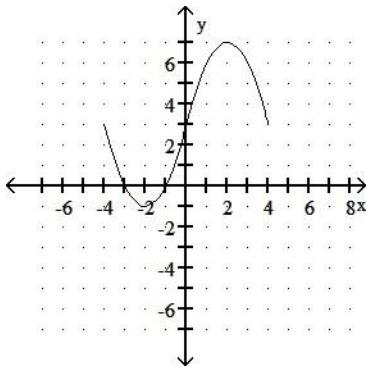

B)

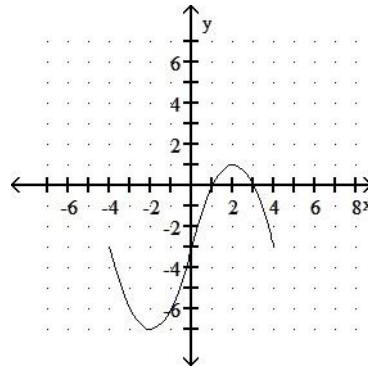

C)

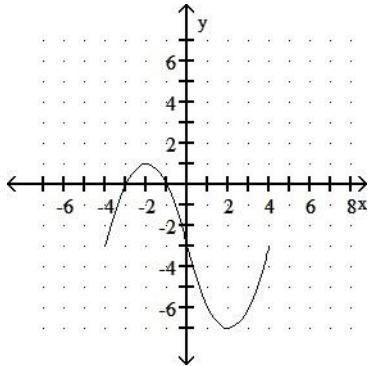

D)

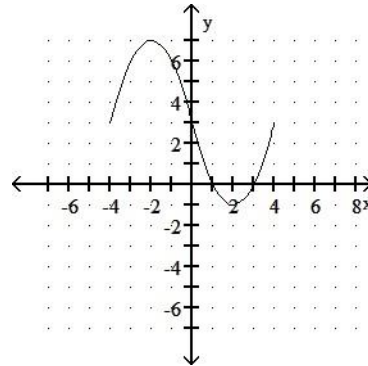

248)  $g(x) = -f(-x) + 4$

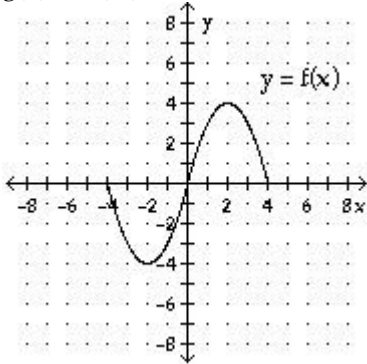

248) \_\_\_\_\_

A)

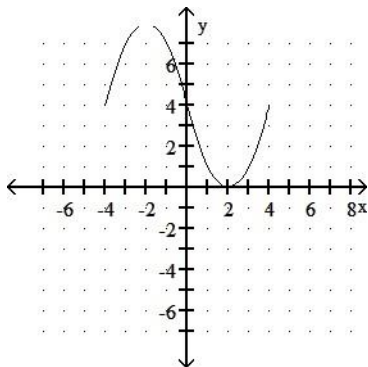

B)

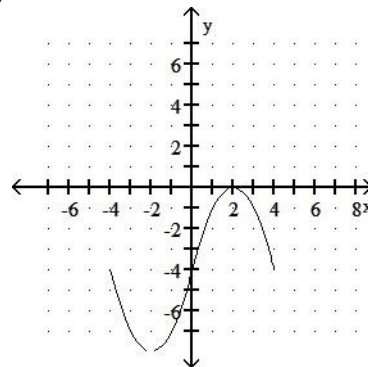

C)

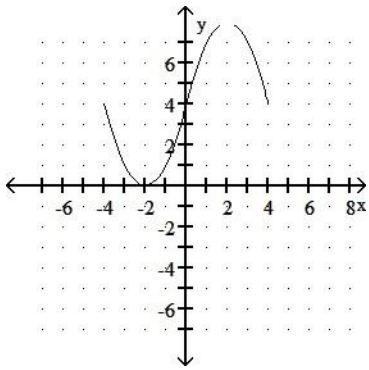

D)

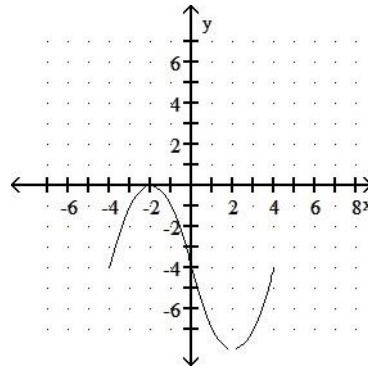

249)  $g(x) = -f(-x) - 2$

249) \_\_\_\_\_

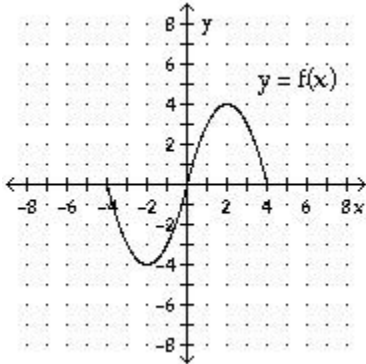

A)

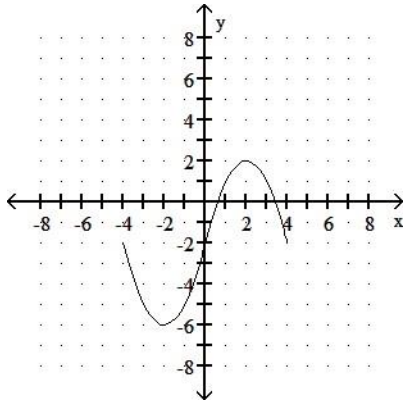

B)

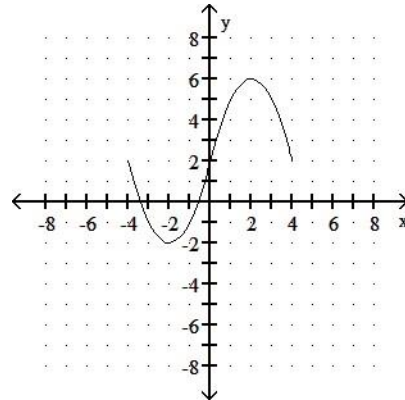

C)

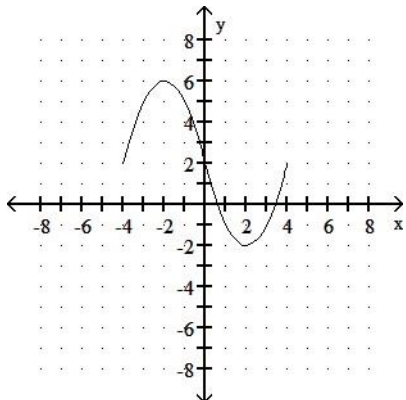

D)

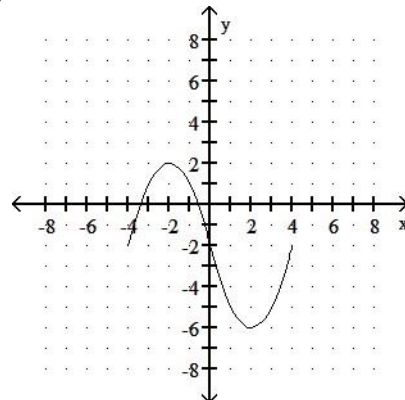

Given the graph of the function  $f(x) = -x^3 + 3x$ ; find a formula for  $g(x)$ .

250)

$f(x) = -x^3 + 3x$

$g(x) =$

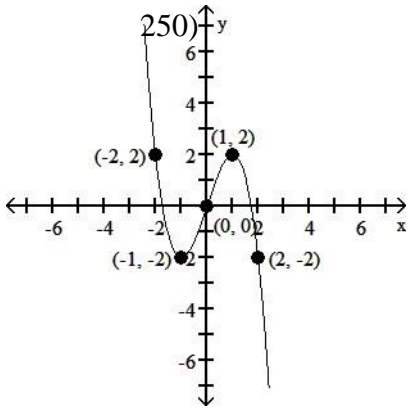

- 250)
- A)  $g(x) = -x^3 + 3x - 2$   
 C)  $g(x) = -(x+2)^3 + 3(x+2)$

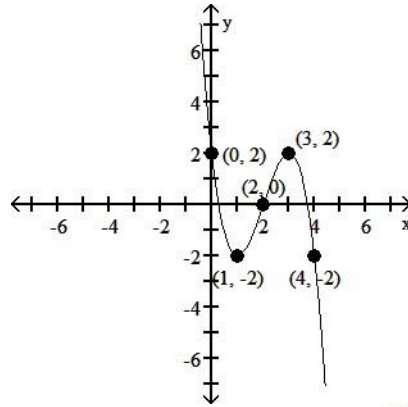

- B)  $g(x) = -x^3 + 3x + 2$   
 D)  $g(x) = -(x-2)^3 + 3(x-2)$

251)

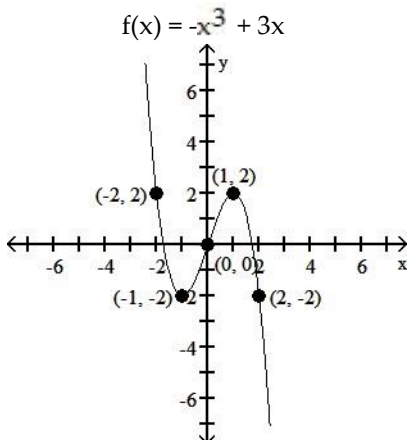

- A)  $g(x) = -x^3 + 3x - 2$   
 C)  $g(x) = -(x-2)^3 + 3(x-2)$

$g(x) =$

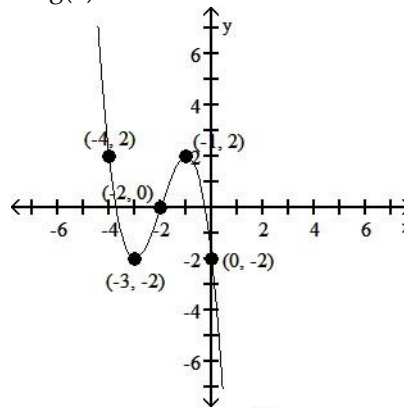

- B)  $g(x) = -x^3 + 3x + 2$   
 D)  $g(x) = -(x+2)^3 + 3(x+2)$

251) \_\_\_\_\_

252)

$f(x) = -x^3 + 3x$

$g(x) =$

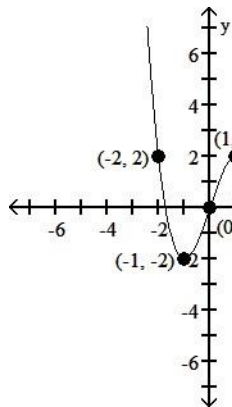

252)

A)  $g(x) = -x^3 + 3x + 3$

C)  $g(x) = -x^3 + 3x - 3$

B)  $g(x) = -(x + 3)^3 + 3(x + 3)$

D)  $g(x) = -(x - 3)^3 + 3(x - 3)$

253)

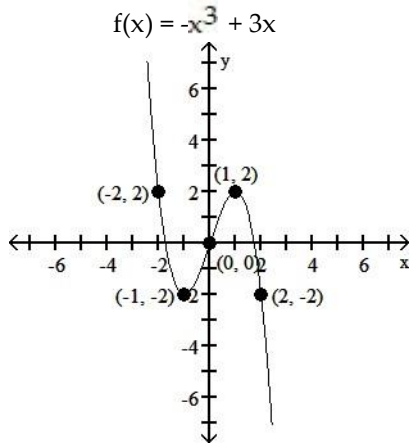

$g(x) =$

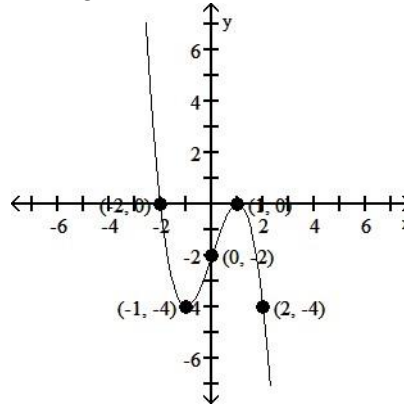

253) \_\_\_\_\_

A)  $g(x) = -(x - 2)^3 + 3(x - 2)$

C)  $g(x) = -x^3 + 3x - 2$

B)  $g(x) = -x^3 + 3x + 2$

D)  $g(x) = -(x + 2)^3 + 3(x + 2)$

254)

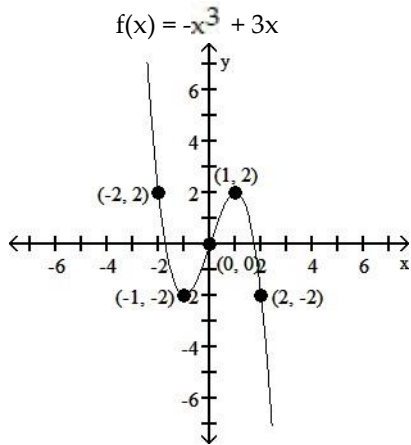

$g(x) =$

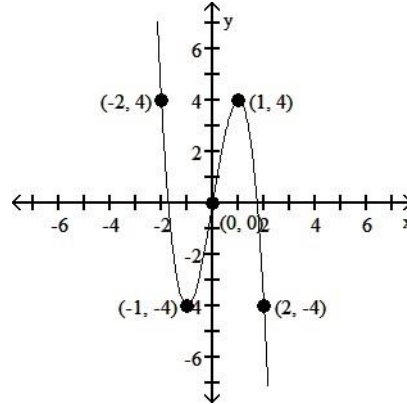

254) \_\_\_\_\_

A)  $g(x) = 2(-x^3 + 3x)$

C)  $g(x) = -(x + 2)^3 + 3(x + 2)$

B)  $g(x) = -x^3 + 3x + 2$

D)  $g(x) = \frac{1}{2}(-x^3 + 3x)$

255)

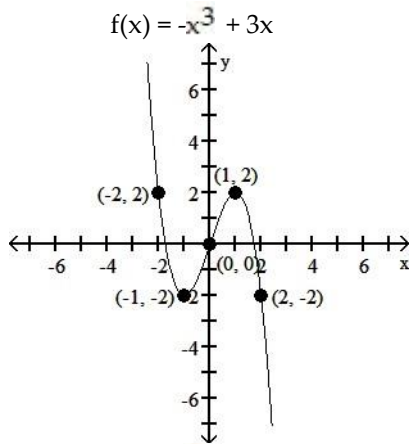

$g(x) =$

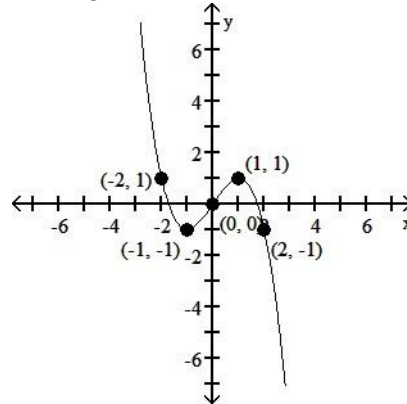

255) \_\_\_\_\_

A)  $g(x) = 2(-x^3 + 3x)$

B)



$$g(x) = -x^3 + 3x - \frac{1}{2}$$

$$\text{C) } g(x) = -x^3 + 3x + \frac{1}{2}$$

$$\text{D) } g(x) = \frac{1}{2}(-x^3 + 3x)$$

Find an equation of variation for the given situation.

256)  $y$  varies directly as  $z$ , and  $y = 24$  when  $z = 168$ .

$$\text{A) } y = 7z$$

$$\text{B) } y = -\frac{1}{2}z$$

$$\text{C) } y = \frac{1}{7}z$$

$$\text{D) } y = -2z$$

256) \_\_\_\_\_

257)  $m$  varies directly as  $p$ , and  $m = 72$  when  $p = 9$ .

$$\text{A) } m = \frac{1}{8}p$$

$$\text{B) } m = 8p$$

$$\text{C) } m = 63p$$

$$\text{D) } m = 81p$$

257) \_\_\_\_\_

258)  $p$  varies directly as  $q$ , and  $p = 1$  when  $q = \frac{1}{17}$ .

$$\text{A) } p = \frac{1}{17}q$$

$$\text{B) } p = 17q$$

$$\text{C) } p = 18q$$

$$\text{D) } p = 16q$$

258) \_\_\_\_\_

259)  $r$  varies directly as  $s$ , and  $r = 0.0588$  when  $s = 1$ .

$$\text{A) } r = 0.0588s$$

$$\text{B) } r = 16s$$

$$\text{C) } r = 18s$$

$$\text{D) } r = 17s$$

259) \_\_\_\_\_

260)  $y$  varies directly as  $x$ , and  $y = 0.7$  when  $x = 0.4$ .

$$\text{A) } y = \frac{7}{4}x$$

$$\text{B) } y = \frac{4}{7}x$$

$$\text{C) } y = 0.3x$$

$$\text{D) } y = 1.1x$$

260) \_\_\_\_\_

261)  $y$  varies inversely as  $x$ , and  $y = 21$  when  $x = 3$

$$\text{A) } y = \frac{63}{x}$$

$$\text{B) } y = \frac{x}{63}$$

$$\text{C) } y = 63x$$

$$\text{D) } y = \frac{1}{63x}$$

261) \_\_\_\_\_

262)  $y$  varies inversely as  $x$ , and  $y = 15$  when  $x = 19$

$$\text{A) } y = \frac{285}{x}$$

$$\text{B) } y = \frac{x}{285}$$

$$\text{C) } y = \frac{1}{285x}$$

$$\text{D) } y = 285x$$

262) \_\_\_\_\_

263)  $y$  varies inversely as  $x$  and  $y = 36$  when  $x = \frac{1}{9}$

$$\text{A) } y = \frac{-5}{x}$$

$$\text{B) } y = \frac{4}{x}$$

$$\text{C) } y = \frac{9}{x}$$

$$\text{D) } y = \frac{13}{x}$$

263) \_\_\_\_\_

264)  $y$  varies inversely as  $x$  and  $y = 0.5$  when  $x = 0.7$

$$\text{A) } y = 0.71x$$

$$\text{B) } y = \frac{0.35}{x}$$

$$\text{C) } y = \frac{0.71}{x}$$

$$\text{D) } y = \frac{1.2}{x}$$

264) \_\_\_\_\_

265)  $y$  varies inversely as  $x$  and  $y = 4.75$  when  $x = 0.48$

$$\text{A) } y = 9.9x$$

$$\text{B) } y = \frac{9.9}{x}$$

$$\text{C) } y = \frac{2.68}{x}$$

$$\text{D) } y = \frac{2.28}{x}$$

265) \_\_\_\_\_

266)  $y$  varies inversely as  $x$  and  $y = 0.75$  when  $x = 32$

$$\text{A) } y = \frac{25}{x}$$

$$\text{B) } y = 24x$$

$$\text{C) } y = \frac{27}{x}$$

$$\text{D) } y = \frac{24}{x}$$

266) \_\_\_\_\_

**Solve.**

- 267) The distance  $D$  that a spring is stretched by a hanging object varies directly as the weight  $W$  of the object. If a 4-kg object stretches a spring 35 cm, how far will a 27-kg weight stretch the spring? 267) \_\_\_\_\_  
A) 8.75 cm                      B) 3.0857 cm                      C) 236.25 cm                      D) 66 cm
- 268) The number  $G$  of gears a machine can make varies directly as the time  $T$  it operates. If it can make 5716 gears in 14 hours, how many gears can it make in 10 hours? 268) \_\_\_\_\_  
A) 4082.86 gears                      B) 408.29 gears                      C) 0.0245 gears                      D) 5740 gears
- 269) According to Ohm's law, the electric current  $I$ , in amperes, in a circuit varies directly as the voltage  $V$ . When 9 volts are applied, the current is 4 amperes. What is the current when 24 volts are applied? 269) \_\_\_\_\_  
A) 2.25 amp                      B) 37 amp                      C) 10.67 amp                      D) 54 amp
- 270) The weight  $W$  of an object on the Moon varies directly as the weight  $E$  on earth. A person who weighs 124 lb on earth weighs 24.8 lb on the Moon. How much would a 117-lb person weigh on the Moon? 270) \_\_\_\_\_  
A) 23.4 lb                      B) 265.8 lb                      C) 585 lb                      D) 0.2 lb
- 271) The time  $T$  necessary to make an enlargement of a photo negative varies directly as the area  $A$  of the enlargement. If 75 seconds are required to make a 5-by-5 enlargement, find the time required for a 7-by-7 enlargement. 271) \_\_\_\_\_  
A) 98 sec                      B) 245 sec                      C) 196 sec                      D) 147 sec
- 272) The weight of a liquid varies directly as its volume  $V$ . If the weight of the liquid in a cubical container 3 cm on a side is 81 g, find the weight of the liquid in a cubical container 4 cm on a side. 272) \_\_\_\_\_  
A) 52 g                      B) 192 g                      C) 12 g                      D) 64 g

**Solve the problem.**

- 273) The pitch  $P$  of a musical tone varies inversely as its wavelength  $W$ . One tone has a pitch of 408 vibrations per second and a wavelength of 5.6 ft. Find the wavelength of another tone that has a pitch of 340 vibrations per second. 273) \_\_\_\_\_  
A) 0.00004 ft                      B) 24,771.4 ft                      C) 6.7 ft                      D) 0.15 ft
- 274) The current  $I$  in an electrical conductor varies inversely as the resistance  $R$  of the conductor. The current is 2 amperes when the resistance is 546 ohms. What is the current when the resistance is 516 ohms? 274) \_\_\_\_\_  
A) 0.47 amp                      B) 2.1 amp                      C) 1.9 amp                      D) 0.53 amp
- 275) The number of miles per gallon of gasoline that a vehicle averages varies inversely as the average speed the car travels. A vehicle gets 29 miles per gallon at 80 mph. How many miles per gallon will it get at 65 mph? 275) \_\_\_\_\_  
A) 0.04 mpg                      B) 35.7 mpg                      C) 0.03 mpg                      D) 23.6 mpg
- 276) The amount of tread left on a tire varies inversely as the number of miles the tire has traveled. A tire that has traveled 54,000 miles has  $\frac{15}{16}$  inches of tread left. How much tread will be left on a tire that has traveled 61,000 miles? 276) \_\_\_\_\_  
A) 57,600 in.                      B)

$$\frac{488}{405} \text{ in.}$$

C)  $\frac{1}{57600}$

D)  $\frac{405}{488}$

in.

in.

277) The weight that a horizontal beam can support varies inversely as the length of the beam. Suppose that a 10-m beam can support 270 kg. How many kilograms can a 5-m beam support? 277) \_\_\_\_\_

- A) 0.1852 kg      B) 540 kg      C) 5.4 kg      D) 0.0019 kg

278) The time it takes to complete a certain job varies inversely as the number of people working on that job. If it takes 36 hours for 7 carpenters to frame a house, then how long will it take 63 carpenters to do the same job? 278) \_\_\_\_\_

- A) 4.0 hr      B) 63 hr      C) 40 hr      D) 12.3 hr

279) The volume V of a gas at constant temperature varies inversely as the pressure P on it. The volume of a gas is  $170 \text{ cm}^3$  under a pressure of  $20 \text{ kg/cm}^2$ . What will be its volume under a pressure of  $40 \text{ kg/cm}^2$ ? 279) \_\_\_\_\_

- A)  $357 \text{ cm}^3$       B)  $340 \text{ cm}^3$       C)  $85 \text{ cm}^3$       D)  $77 \text{ cm}^3$

280) The speed of a vehicle is inversely proportional to the time it takes to travel a fixed distance. If a vehicle travels a fixed distance at 30 miles per hour in 60 minutes, how fast must it travel to cover the same distance in 25 minutes? 280) \_\_\_\_\_

- A)  $\frac{25}{2}$  mph      B)  $\frac{2}{25}$  mph      C) 50 mph      D) 72 mph

**Find an equation of variation for the given situation.**

281) y varies inversely as the square of x, and  $y = 9$  when  $x = 7$  281) \_\_\_\_\_

- A)  $y = 63x$       B)  $y = \frac{441}{x^2}$       C)  $y = 63x^2$       D)  $y = \frac{439}{x^2}$

282) y varies inversely as the square of x, and  $y = 0.12$  when  $x = 0.6$  282) \_\_\_\_\_

- A)  $y = \frac{0.0432}{x^2}$       B)  $y = .57x^2$       C)  $y = \frac{0.072}{x^2}$       D)  $y = \frac{0.072}{x}$

283) s varies directly as the square of t, and  $s = 64$  when  $t = 4$ . 283) \_\_\_\_\_

- A)  $s = \frac{1}{4}t^2$       B)  $s = \frac{1}{16}t^2$       C)  $s = 16t^2$       D)  $s = 4t^2$

284) y varies directly as the square of x, and  $y = 22.05$  when  $x = 7$ . 284) \_\_\_\_\_

- A)  $y = 0.49\sqrt{x}$       B)  $y = 0.45x^2$       C)  $y = 0.5x^2$       D)  $y = 2.02x^2$

285) y varies jointly as x and z, and  $y = 135$  when  $x = 9$  and  $z = 3$  285) \_\_\_\_\_

- A)  $y = 5xz$       B)  $y = \frac{135}{xz}$       C)  $y = 15x$       D)  $y = 7xz$

286) y varies jointly as x and the square of z, and  $y = 500$  when  $x = 4$  and  $z = 5$  286) \_\_\_\_\_

- A)  $y = 25xz$       B)  $y = 6xz^2$       C)  $y = \frac{100}{x\sqrt{z}}$       D)  $y = 5xz^2$

287) y varies jointly as x and z, and  $y = 91$  when  $x = 5.2$  and  $z = 7$  287) \_\_\_\_\_

A)  $y = 0.25xz$

B)  $y = 5.5xz$

C)  $y = \frac{2.5}{xz}$

D)  $y = 2.5xz$

288)  $y$  varies jointly as  $x$  and the square of  $z$ , and  $y = 60.9854$  when  $x = 0.2$  and  $z = 4.9$ 

288) \_\_\_\_\_

A)  $y = 14.9xz^2$

B)  $y = 12.7xz^2$

C)  $y = 13.2x\sqrt{z}$

D)  $y = 2.54x^2z^2$

289)  $y$  varies directly as  $x$  and inversely as  $z$ , and  $y = 5$  when  $x = 10$  and  $z = 16$ .

289) \_\_\_\_\_

A)  $y = \frac{5x}{z}$

B)  $y = \frac{8x}{z}$

C)  $y = 8xz$

D)  $y = 5xz$

290)  $y$  varies jointly as  $x$  and  $z$  and inversely as  $w$ , and  $y = \frac{105}{2}$  when  $x = 7$ ,  $z = 9$ , and  $w = 6$ .

290) \_\_\_\_\_

A)  $y = \frac{105xz}{2w}$

B)  $y = 5xzw$

C)  $y = \frac{105}{2}xzw$

D)  $y = \frac{5xz}{w}$

291)  $y$  varies jointly as  $x$  and the square of  $z$  and inversely as  $w$ , and  $y = \frac{160}{3}$  when  $x = 2$ ,  $z = 4$ , and  $w = 3$ .

291) \_\_\_\_\_

A)  $y = \frac{5xz^2}{w}$

B)  $y = \frac{20xz}{w}$

C)  $y = \frac{20xz^2}{w}$

D)  $y = \frac{5xz}{w}$

292)  $y$  varies directly as  $x$  and inversely as  $z$ , and  $y = 14$  when  $x = 2$  and  $z = 8$ .

292) \_\_\_\_\_

A)  $y = \frac{55z}{x}$

B)  $y = \frac{60x}{z}$

C)  $y = \frac{56x}{z}$

D)  $y = 59xz$

293)  $y$  varies directly as  $x$  and inversely as  $z$ , and  $y = 5.4$  when  $x = 2$  and  $z = 1.9$ .

293) \_\_\_\_\_

A)  $y = 9.26xz$

B)  $y = \frac{12.7x}{z}$

C)  $y = \frac{5.13x}{z}$

D)  $y = \frac{x}{z}$

294)  $y$  varies jointly as  $x$  and  $w$  and inversely as  $z$ , and  $y = \frac{9}{2}$  when  $x = 2$ ,  $w = 4$ , and  $z = 16$ .

294) \_\_\_\_\_

A)  $y = \frac{9xw}{z}$

B)  $y = \frac{6xw}{z^2}$

C)  $y = 4xwz$

D)  $y = \frac{6z}{xw}$

295)  $y$  varies jointly as  $x$  and  $p$  and inversely as the square of  $s$ , and  $y = \frac{9}{2}$  when  $x = 1$ ,  $p = 9$ , and  $s = 8$ .

295) \_\_\_\_\_

A)  $y = \frac{256x^2p}{s^2}$

B)  $y = \frac{32xp}{s^2}$

C)  $y = 13xps^2$

D)  $y = \frac{36xp^2}{s}$

296)  $y$  varies jointly as  $x$  and  $z$  and inversely as the product of  $w$  and  $p$ , and  $y = \frac{6}{5}$  when  $x = 1$ ,  $z = 6$ ,  $w = 5$  and  $p = 6$ .

296) \_\_\_\_\_

A)  $y = \frac{9wp}{xz}$

B)  $y = \frac{6xz}{wp}$

C)  $y = 37pwxz$

D)  $y = \frac{36xz}{wp}$

**Solve the problem.**

297) The distance an object falls when dropped from a tower varies directly as the square of the time it falls.

If the object falls 144 feet in 3 seconds, how far will it fall in 14 seconds?

- A) 2744 ft                      B) 3528 ft                      C) 3136 ft                      D) 224 ft

298) The distance it takes to stop a car varies directly as the square of the speed of the car. If it takes 112 feet for a car traveling at 40 miles per hour to stop, what distance is required for a speed of 61 miles per hour? 298) \_\_\_\_\_

- A) 260.81 ft                      B) 260.47 ft                      C) 272.77 ft                      D) 223.26 ft

299) The area of a circle varies directly as the square of the radius of the circle. If a circle with a radius of 5 inches has an area of 78.5 square inches, what is the area of a circle with a radius of 19 inches? 299) \_\_\_\_\_

- A) 1135.94 in<sup>2</sup>                      B) 1133.54 in<sup>2</sup>                      C) 59.66 in<sup>2</sup>                      D) 119.32 in<sup>2</sup>

300) The intensity I of light varies inversely as the square of the distance D from the source. If the intensity of illumination on a screen 5 ft from a light is 2 foot-candles, find the intensity on a screen 10 ft from the light. 300) \_\_\_\_\_

- A)  $1 \frac{1}{2}$  foot-candles                      B) 2 foot-candles  
C)  $\frac{2}{5}$  foot-candle                      D)  $\frac{1}{2}$  foot-candle

301) The weight of a body above the surface of the earth varies inversely as the square of its distance from the center of the earth. What is the effect on the weight when the distance is multiplied by 2? 301) \_\_\_\_\_

- A) The weight is multiplied by 2.                      B) The weight is divided by 4.  
C) The weight is multiplied by 4.                      D) The weight is divided by 2.

302) The gravitational attraction A between two masses varies inversely as the square of the distance between them. The force of attraction is 4 lb when the masses are 3 ft apart, what is the attraction when the masses are 6 ft apart? 302) \_\_\_\_\_

- A) 2 lb                      B) 4 lb                      C) 3 lb                      D) 1 lb

303) The weight of a person on or above the surface of the earth varies inversely as the square of the distance the person is from the center of the earth. If a person weighs 180 pounds on the surface of the earth and the radius of the earth is 3900 miles, what will the person weigh if he or she is 275 miles above the earth's surface? Round your answer to the nearest tenth of a pound. 303) \_\_\_\_\_

- A) 157.47 lb                      B) 157.07 lb                      C) 158.47 lb                      D) 156.57 lb

304) The intensity of light from a light source varies inversely as the square of the distance from the source. Suppose the the intensity is 40 foot-candles at a distance of 10 feet. What will the intensity be at a distance of 13 feet? Round your answer to the tenths place. 304) \_\_\_\_\_

- A) 23.4 foot-candles                      B) 23.1 foot-candles  
C) 23.7 foot-candles                      D) 23.9 foot-candles

- 305) The intensity of a radio signal from the radio station varies inversely as the square of the distance from the station. Suppose the the intensity is 8000 units at a distance of 2 miles. What will the intensity be at a distance of 13 miles? Round your answer to the nearest unit. 305) \_\_\_\_\_  
 A) 215 units                      B) 153 units                      C) 189 units                      D) 172 units
- 306) The volume  $V$  of a given mass of gas varies directly as the temperature  $T$  and inversely as the pressure  $P$ . If  $V = 220.0 \text{ in.}^3$  when  $T = 300^\circ$  and  $P = 15 \text{ lb/in.}^2$ , what is the volume when  $T = 130^\circ$  and  $P = 20 \text{ lb/in.}^2$ ? 306) \_\_\_\_\_  
 A)  $91.5 \text{ in}^3$                       B)  $71.5 \text{ in}^3$                       C)  $31.5 \text{ in}^3$                       D)  $61.5 \text{ in}^3$
- 307) At a fixed temperature, the resistance  $R$  of a wire varies directly as the length  $l$  and inversely as the square of its diameter  $d$ . If the resistance is 0.52 ohm when the diameter is 1 mm and the length is 260 cm, what is the resistance when the diameter is 2 mm and the length is 990 cm? 307) \_\_\_\_\_  
 A) 247.5 ohm                      B) 0.99 ohm                      C) 0.495 ohm                      D) 128.7 ohm
- 308) Wind resistance or atmospheric drag tends to slow down moving objects. Atmospheric drag varies jointly as an object's surface area  $A$  and velocity  $v$ . If a car traveling at a speed of 30 mph with a surface area of  $39 \text{ ft}^2$  experiences a drag of 163.8 N (Newtons), how fast must a car with  $44 \text{ ft}^2$  of surface area travel in order to experience a drag force of 264.88 N? 308) \_\_\_\_\_  
 A) 48 mph                      B) 45 mph                      C) 43 mph                      D) 40 mph
- 309) The cost of stainless steel tubing varies jointly as the length and the diameter of the tubing. If a 5 foot length with diameter 2 inches costs \$48.00, how much will a 19 foot length with diameter 6 inches cost? 309) \_\_\_\_\_  
 A) \$544.80                      B) \$552.50                      C) \$547.20                      D) \$552.77
- 310) The resistance of a wire varies directly as the length of the wire and inversely as the square of the diameter of the wire. A 20 foot length of wire with a diameter of 0.1 inch has a resistance of 3 ohms. What would the resistance be for a 46 foot length, with diameter 0.01 inch, of the same kind of wire? 310) \_\_\_\_\_  
 A) 702 ohms                      B) 687.5 ohms                      C) 683 ohms                      D) 690 ohms
- 311) The force needed to keep a car from skidding on a curve varies jointly as the weight of the car and the square of the car's speed, and inversely as the radius of the curve. If a force of 3600 pounds is needed to keep an 1800 pound car traveling at 20 mph from skidding on a curve of radius 600 feet, what force would be required to keep the same car from skidding on a curve of radius 630 feet at 60 mph? Round your answer to the nearest pound of force? 311) \_\_\_\_\_  
 A) 30,725 lb                      B) 30,889 lb                      C) 31,427 lb                      D) 30,857 lb
- 312) The volume of wood in a tree varies jointly as the height of the tree and the square of the distance around the tree trunk. If the volume of wood is 15.84 cubic feet when the height is 22 feet and the distance around the trunk is 3 feet, what is the volume of wood obtained from a tree that is 37 feet tall having a measurement of 5 feet around the trunk? 312) \_\_\_\_\_  
 A)  $66 \text{ ft}^3$                       B)  $74 \text{ ft}^3$                       C)  $83 \text{ ft}^3$                       D)  $78 \text{ ft}^3$

- 1) B
- 2) D
- 3) D
- 4) D
- 5) D
- 6) D
- 7) A
- 8) C
- 9) C
- 10) A
- 11) A
- 12) C
- 13) C
- 14) D
- 15) C
- 16) D
- 17) C
- 18) D
- 19) C
- 20) C
- 21) C
- 22) D
- 23) C
- 24) A
- 25) D
- 26) D
- 27) A
- 28) C
- 29) C
- 30) C
- 31) B
- 32) C
- 33) D
- 34) A
- 35) D
- 36) C
- 37) C
- 38) D
- 39) B
- 40) A
- 41) D
- 42) D
- 43) B
- 44) C
- 45) C
- 46) D
- 47) C
- 48) D
- 49) A
- 50) A

- 51) B
- 52) C
- 53) D
- 54) C
- 55) B
- 56) B
- 57) A
- 58) B
- 59) A
- 60) C
- 61) A
- 62) D
- 63) B
- 64) B
- 65) C
- 66) A
- 67) D
- 68) D
- 69) D
- 70) B
- 71) A
- 72) D
- 73) C
- 74) C
- 75) C
- 76) D
- 77) D
- 78) C
- 79) A
- 80) B
- 81) D
- 82) C
- 83) A
- 84) B
- 85) B
- 86) C
- 87) B
- 88) A
- 89) B
- 90) B
- 91) D
- 92) B
- 93) C
- 94) C
- 95) D
- 96) B
- 97) D
- 98) A
- 99) D
- 100) B
- 101) C



102) D  
103) A  
104) D  
105) B  
106) D  
107) D  
108) A  
109) A  
110) A  
111) C  
112) C  
113) A  
114) C  
115) D  
116) A  
117) D  
118) D  
119) D  
120) D  
121) A  
122) D  
123) A  
124) A  
125) D  
126) A  
127) B  
128) B  
129) B  
130) B  
131) D  
132) B  
133) D  
134) A  
135) A  
136) B  
137) A  
138) A  
139) A  
140) A  
141) C  
142) B  
143) B  
144) B  
145) D  
146) A  
147) B  
148) D  
149) B  
150) A  
151) A  
152) C

153) C  
154) B  
155) D  
156) D  
157) D  
158) D  
159) A  
160) A  
161) D  
162) D  
163) A  
164) B  
165) C  
166) D  
167) D  
168) D  
169) B  
170) D  
171) C  
172) A  
173) A  
174) B  
175) A  
176) B  
177) A  
178) C  
179) C  
180) C  
181) C  
182) C  
183) A  
184) B  
185) A  
186) C  
187) B  
188) B  
189) A  
190) C  
191) A  
192) A  
193) C  
194) D  
195) A  
196) C  
197) A  
198) B  
199) C  
200) A  
201) D  
202) A  
203) C

204) A  
205) C  
206) C  
207) B  
208) D  
209) A  
210) C  
211) B  
212) B  
213) D  
214) B  
215) D  
216) C  
217) A  
218) C  
219) A  
220) D  
221) D  
222) D  
223) C  
224) A  
225) B  
226) D  
227) A  
228) B  
229) B  
230) D  
231) D  
232) C  
233) D  
234) C  
235) D  
236) A  
237) A  
238) B  
239) C  
240) C  
241) C  
242) D  
243) C  
244) A  
245) C  
246) B  
247) C  
248) C  
249) A  
250) D  
251) D  
252) A  
253) C  
254) A

255) D  
256) C  
257) B  
258) B  
259) A  
260) A  
261) A  
262) A  
263) B  
264) B  
265) D  
266) D  
267) C  
268) A  
269) C  
270) A  
271) D  
272) B  
273) C  
274) B  
275) B  
276) D  
277) B  
278) A  
279) C  
280) D  
281) B  
282) A  
283) D  
284) B  
285) A  
286) D  
287) D  
288) B  
289) B  
290) D  
291) A  
292) C  
293) C  
294) A  
295) B  
296) B  
297) C  
298) B  
299) B  
300) D  
301) B  
302) D  
303) B  
304) C  
305) C

- 306) B
- 307) C
- 308) C
- 309) C
- 310) D
- 311) D
- 312) B