

Exam

Name _____

MULTIPLE CHOICE. Choose the one alternative that best completes the statement or answers the question.
Name the quadrant in which the point is located.

1) (11, 4) 1) _____
A) I B) II C) III D) IV

2) (-15, 17) 2) _____
A) I B) II C) III D) IV

3) (-5, -5) 3) _____
A) I B) II C) III D) IV

4) (14, -7) 4) _____
A) I B) II C) III D) IV

Identify the points in the graph for the ordered pairs.

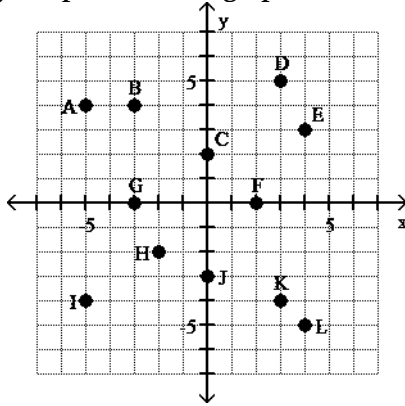

5) (0, 2), (4, 3) 5) _____
A) F and E B) C and K C) C and E D) B and C

6) (-5, -4), (0, -3) 6) _____
A) G and I B) I and J C) A and J D) A and G

7) (-3, 4), (2, 0), (4, -5) 7) _____
A) B, C, and L B) F, K, and L C) B, F, and L D) A, B, and F

8) (3, 5), (-3, 0) 8) _____
A) L and J B) D and J C) I and G D) D and G

Give the coordinates of the points shown on the graph.

9)

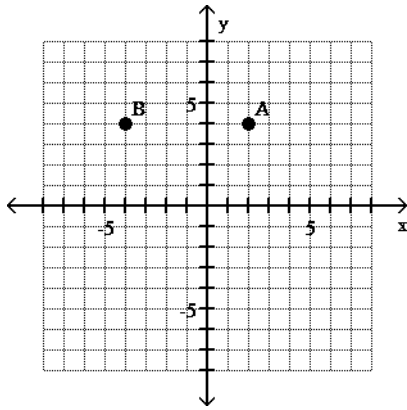

9) _____

- A) $A = (2, 4)$, $B = (4, 4)$ B) $A = (2, 4)$, $B = (-4, 4)$
 C) $A = (4, 20)$, $B = (4, -4)$ D) $A = (2, 4)$, $B = (4, -4)$

10)

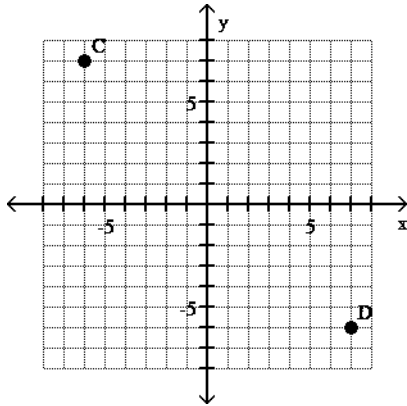

10) _____

- A) $C = (-6, -6)$, $D = (7, -6)$ B) $C = (7, -6)$, $D = (-6, 7)$
 C) $C = (-6, 7)$, $D = (-6, 7)$ D) $C = (-6, 7)$, $D = (7, -6)$

11)

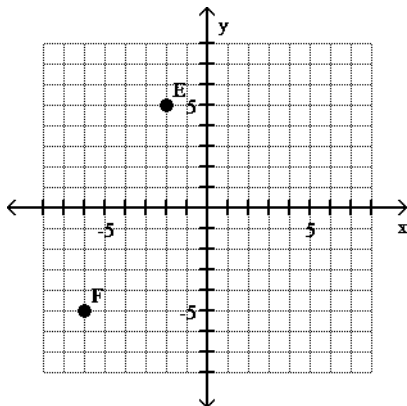

11) _____

- A) $E = (-2, 5)$, $F = (-6, -5)$ B) $E = (-6, -5)$, $F = (-2, 5)$
 C) $E = (5, -2)$, $F = (-5, -6)$ D) $E = (-2, -5)$, $F = (5, -5)$

12)

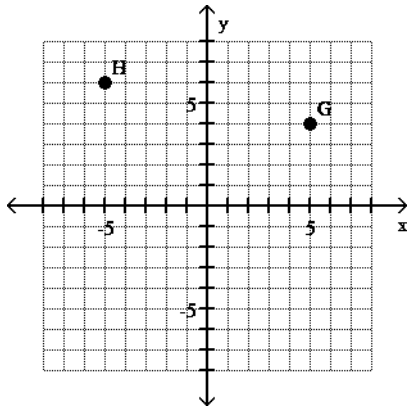

12) _____

- A) $G = (4, 5)$, $H = (6, -5)$ B) $G = (5, 6)$, $H = (4, 6)$
 C) $G = (5, 4)$, $H = (6, -5)$ D) $G = (5, 4)$, $H = (-5, 6)$

Plot the point in the xy -plane. Tell in which quadrant or on what axis the point lies.

13) $(1, 6)$

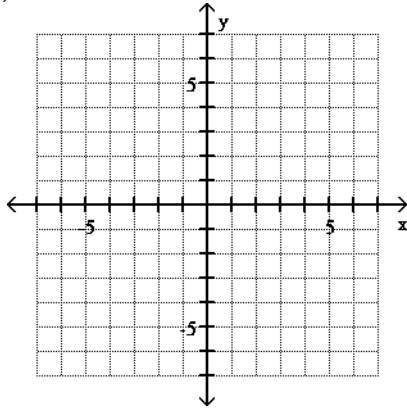

13) _____

A)

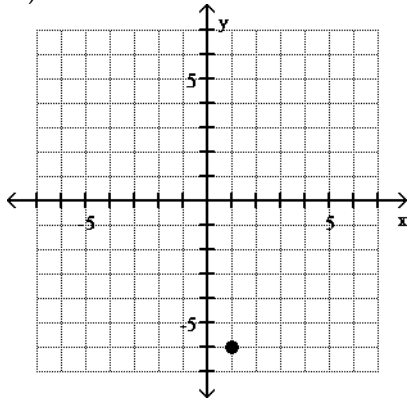

Quadrant IV B)

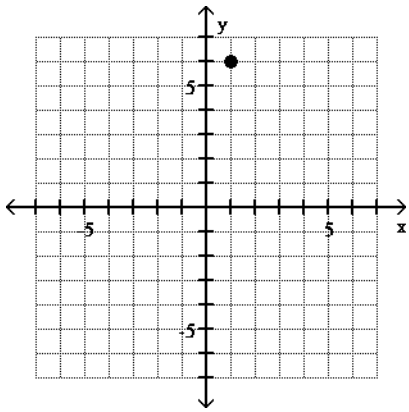

Quadrant I

C)

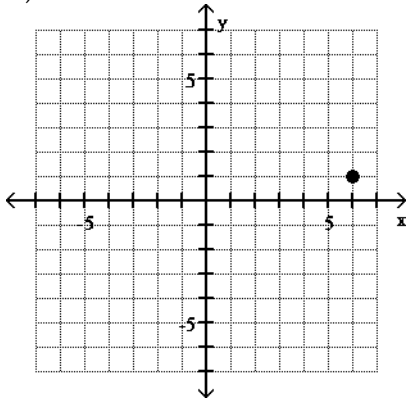

Quadrant I

D)

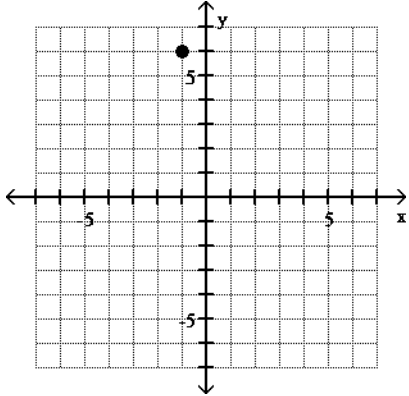

Quadrant II

14) (-1, 3)

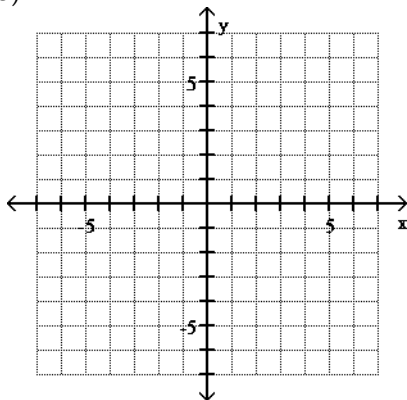

14) _____

A)

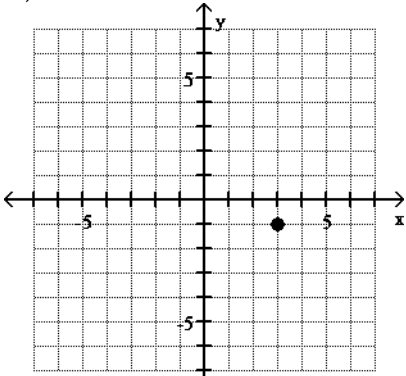

Quadrant IV

B)

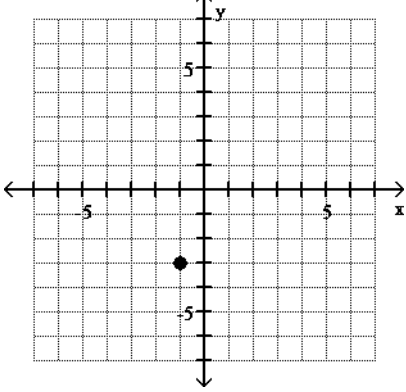

Quadrant III

C)

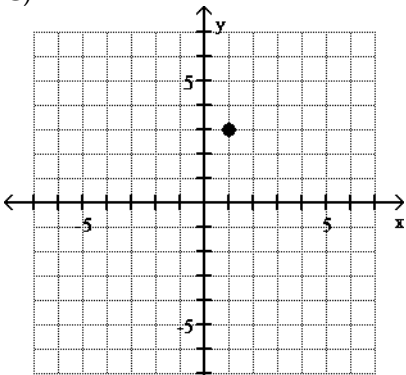

Quadrant I

D)

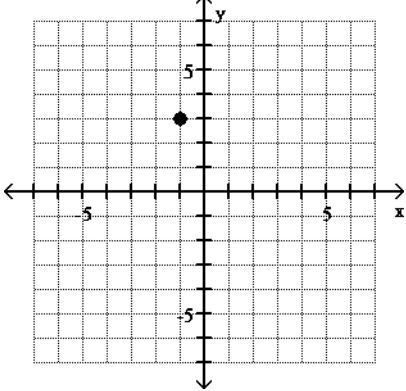

Quadrant II

15) (1, -2)

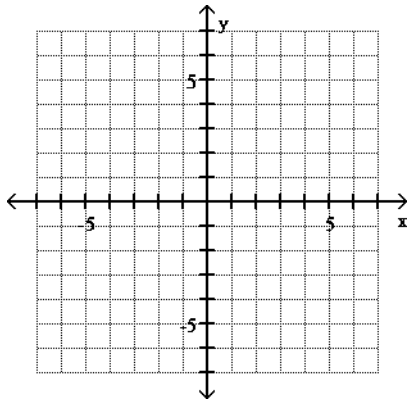

15) _____

A)

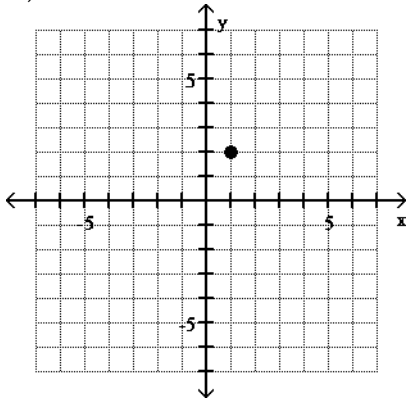

Quadrant I

B)

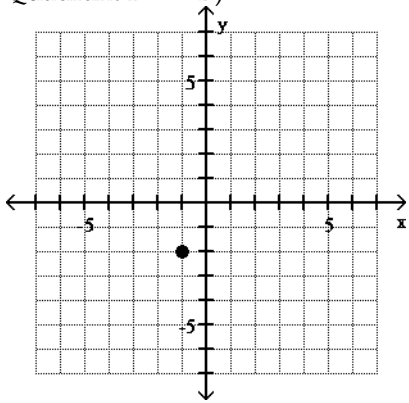

Quadrant III

C)

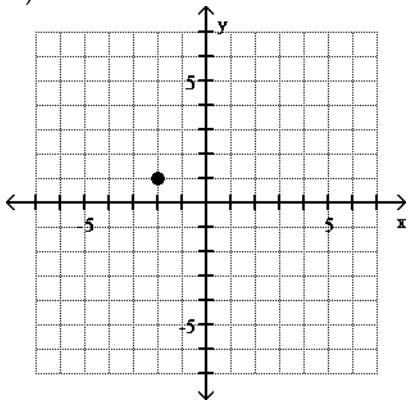

Quadrant II

D)

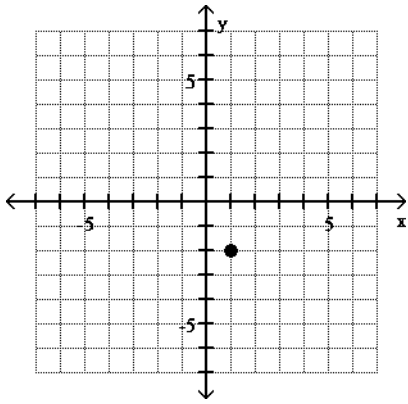

Quadrant IV

16) (-6, -4)

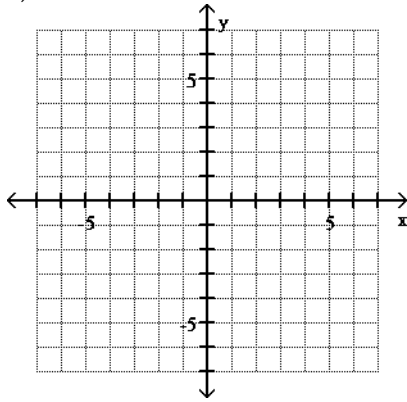

16) _____

A)

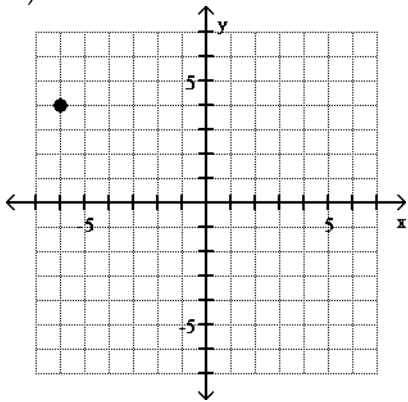

Quadrant II

B)

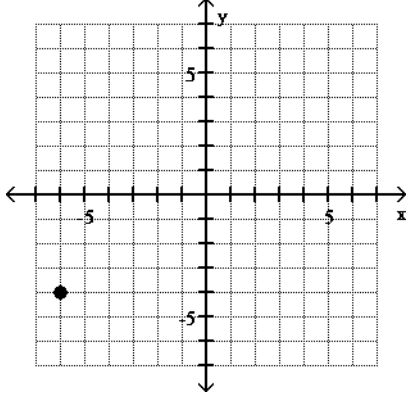

Quadrant III

C)

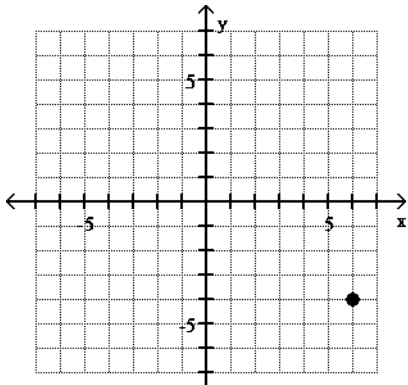

Quadrant IV

D)

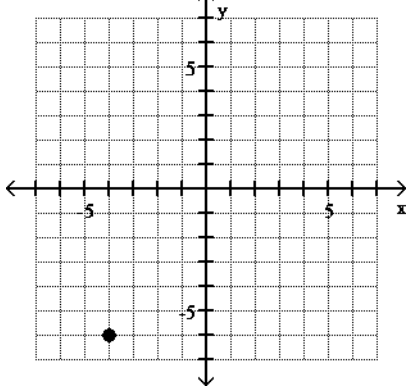

Quadrant III

17) (0, -6)

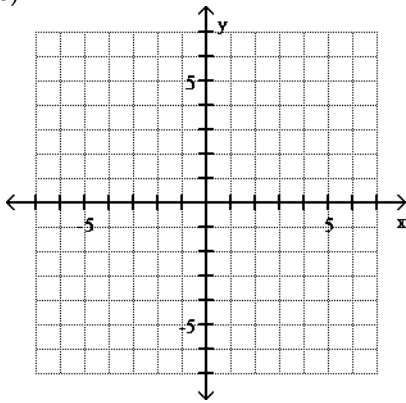

17) _____

A)

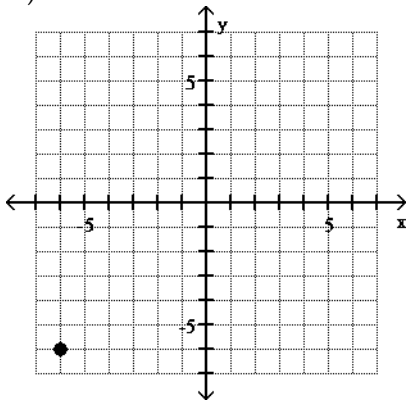

Quadrant II

B)

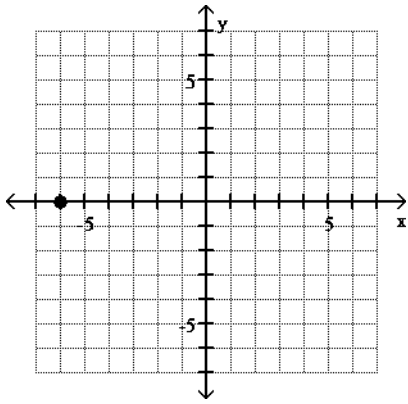

x-axis

C)

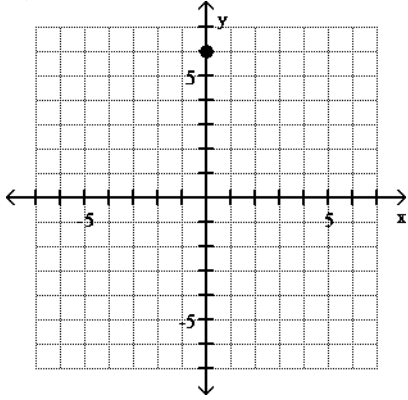

y-axis D)

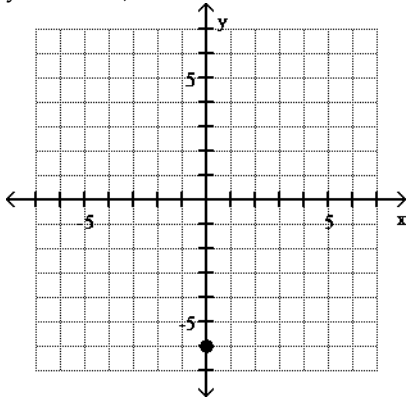

y-axis

18) (2, 0)

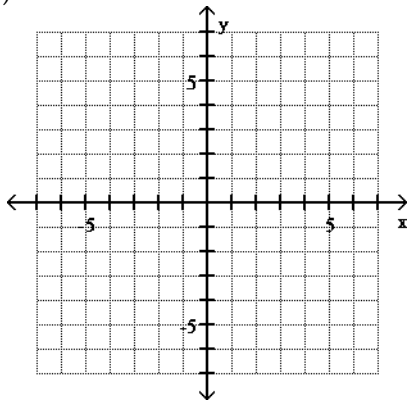

18) _____

A)

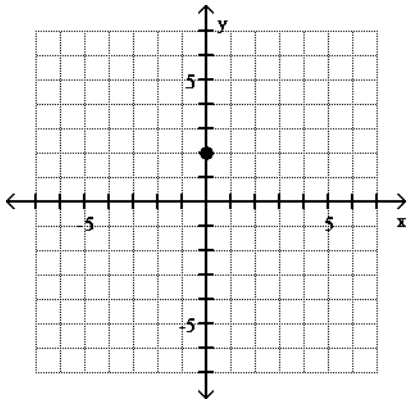

y-axis B)

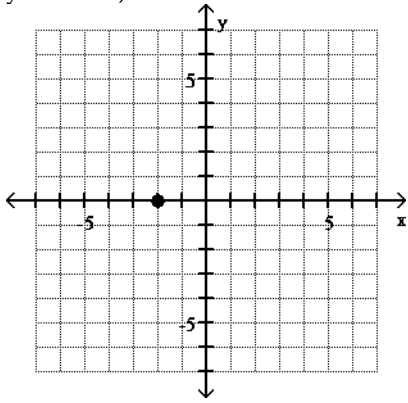

x-axis

C)

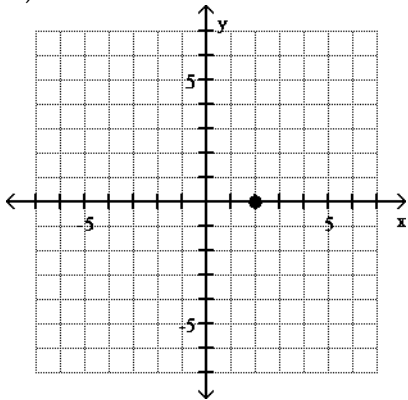

x-axis D)

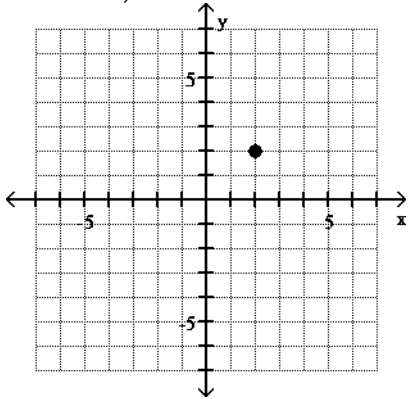

Quadrant II

Find the distance $d(P_1, P_2)$ between the points P_1 and P_2 .
19)

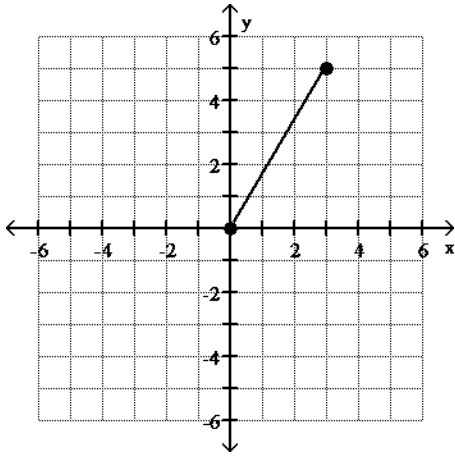

19) _____

- A) 1 B) $\sqrt{34}$ C) 3 D) $\sqrt{2}$

20)

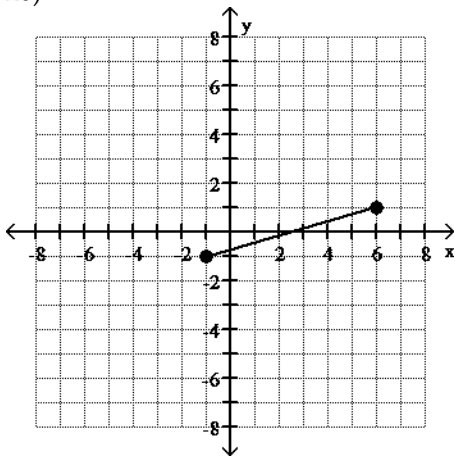

20) _____

- A) $3\sqrt{5}$ B) 14 C) $\sqrt{53}$ D) 5

21)

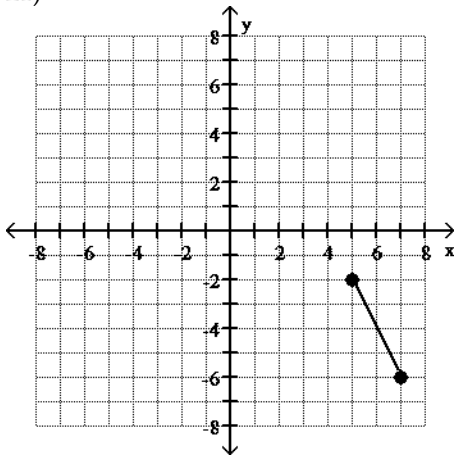

21) _____

- A) $2\sqrt{5}$ B) $12\sqrt{3}$ C) 6 D) 12

22)

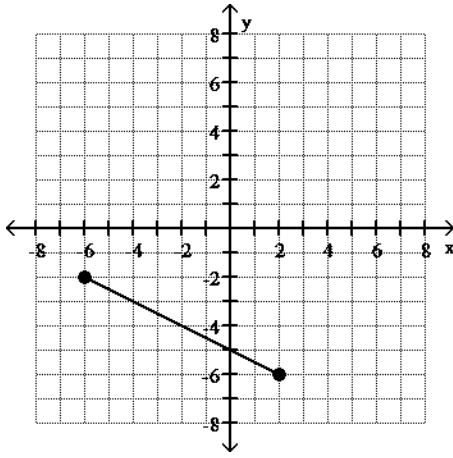

22) _____

- A) $48\sqrt{3}$ B) 12 C) 48 D) $4\sqrt{5}$

23) $P_1 = (4, 4); P_2 = (4, -5)$ 23) _____
 A) 3 B) 8 C) 9 D) 10

24) $P_1 = (1, -4); P_2 = (-5, -12)$ 24) _____
 A) 20 B) 11 C) 100 D) 10

25) $P_1 = (0, 10); P_2 = (-8, 10)$ 25) _____
 A) $2\sqrt{41}$ B) 8 C) 10 D) 64

26) $P_1 = (0, 0); P_2 = (-1, -8)$ 26) _____
 A) $\sqrt{65}$ B) $21\sqrt{2}$ C) 65 D) 9

27) $P_1 = (1, 6); P_2 = (-7, -1)$ 27) _____
 A) $\sqrt{15}$ B) 56 C) 1 D) $\sqrt{113}$

28) $P_1 = (3, -1); P_2 = (7, -3)$ 28) _____
 A) 6 B) $12\sqrt{3}$ C) $2\sqrt{5}$ D) 12

29) $P_1 = (-3, -4); P_2 = (6, 2)$ 29) _____
 A) 3 B) $3\sqrt{13}$ C) $45\sqrt{5}$ D) 45

30) $P_1 = (-0.1, -0.9); P_2 = (1.5, -1.8)$ Round to three decimal places, if necessary. 30) _____
 A) 5.805 B) 1.936 C) 12.5 D) 1.836

Decide whether or not the points are the vertices of a right triangle.

31) (3, -2), (8, -2), (8, 2) 31) _____
 A) Yes B) No

32) (3, -4), (5, 0), (7, -1) 32) _____
 A) Yes B) No

33) (-8, 5), (-2, 7), (-3, 2) 33) _____

A) Yes B) No

34) (-10, -1), (-4, 1), (2, -6) 34) _____

A) Yes B) No

Solve the problem.

35) Find all values of k so that the given points are $\sqrt{29}$ units apart.
(-5, 5), (k, 0) 35) _____

A) -7 B) 3, 7 C) 7 D) -3, -7

36) Find the area of the right triangle ABC with A = (-2, 7), B = (7, -1), C = (3, 9). 36) _____

A) $\frac{\sqrt{58}}{2}$ square units B) 29 square units
C) 58 square units D) $\frac{\sqrt{29}}{2}$ square units

37) Find all the points having an x-coordinate of 9 whose distance from the point (3, -2) is 10. 37) _____

A) (9, -12), (9, 8) B) (9, 13), (9, -7) C) (9, 6), (9, -10) D) (9, 2), (9, -4)

38) A middle school's baseball playing field is a square, 60 feet on a side. How far is it directly from home plate to second base (the diagonal of the square)? If necessary, round to the nearest foot. 38) _____

A) 92 feet B) 84 feet C) 85 feet D) 86 feet

39) A motorcycle and a car leave an intersection at the same time. The motorcycle heads north at an average speed of 20 miles per hour, while the car heads east at an average speed of 48 miles per hour. Find an expression for their distance apart in miles at the end of t hours. 39) _____

A) 52t miles B) $2t\sqrt{13}$ miles C) $t\sqrt{68}$ miles D) $52\sqrt{t}$ miles

40) A rectangular city park has a jogging loop that goes along a length, width, and diagonal of the park. To the nearest yard, find the length of the jogging loop, if the length of the park is 125 yards and its width is 75 yards. 40) _____

A) 146 yards B) 346 yards C) 145 yards D) 345 yards

41) Find the length of each side of the triangle determined by the three points P_1 , P_2 , and P_3 . State whether the triangle is an isosceles triangle, a right triangle, neither of these, or both.

$P_1 = (-5, -4)$, $P_2 = (-3, 4)$, $P_3 = (0, -1)$ 41) _____

A) $d(P_1, P_2) = 2\sqrt{17}$; $d(P_2, P_3) = \sqrt{34}$; $d(P_1, P_3) = 5\sqrt{2}$
neither
B) $d(P_1, P_2) = 2\sqrt{17}$; $d(P_2, P_3) = \sqrt{34}$; $d(P_1, P_3) = 5\sqrt{2}$
right triangle
C) $d(P_1, P_2) = 2\sqrt{17}$; $d(P_2, P_3) = \sqrt{34}$; $d(P_1, P_3) = \sqrt{34}$
both
D) $d(P_1, P_2) = 2\sqrt{17}$; $d(P_2, P_3) = \sqrt{34}$; $d(P_1, P_3) = \sqrt{34}$
isosceles triangle

Find the midpoint of the line segment joining the points P_1 and P_2 .

42) $P_1 = (2, 1)$; $P_2 = (8, 5)$ 42) _____
 A) (-6, -4) B) (10, 6) C) (5, 3) D) (3, 5)

43) $P_1 = (1, 8)$; $P_2 = (-9, 2)$ 43) _____
 A) (-8, 10) B) (-4, 5) C) (5, 3) D) (10, 6)

44) $P_1 = (7, 1)$; $P_2 = (-16, -16)$ 44) _____
 A) (9, 15) B) $(\frac{23}{2}, \frac{17}{2})$ C) $(-\frac{9}{2}, -\frac{15}{2})$ D) (-9, -15)

45) $P_1 = (-0.6, 0.9)$; $P_2 = (2.6, -2.2)$ 45) _____
 A) (-1.55, 1.6) B) (-0.65, 1) C) (1.6, -1.55) D) (1, -0.65)

46) $P_1 = (b, 9)$; $P_2 = (0, 3)$ 46) _____
 A) $(\frac{b}{2}, 6)$ B) $(-\frac{b}{2}, 6)$ C) (b, 6) D) (b, 12)

47) $P_1 = (3a, 5)$; $P_2 = (4a, 6)$ 47) _____
 A) $(\frac{7a}{2}, \frac{11}{2})$ B) (a, 1) C) $(\frac{11a}{2}, \frac{7}{2})$ D) (7a, 11)

Solve the problem.

48) If (-2, -4) is the endpoint of a line segment, and (1, -2) is its midpoint, find the other endpoint. 48) _____
 A) (2, 2) B) (4, 0) C) (-8, -8) D) (4, -6)

49) If (-4, 2) is the endpoint of a line segment, and (-9, -1) is its midpoint, find the other endpoint. 49) _____
 A) (-14, 5) B) (-10, -8) C) (-14, -4) D) (6, 8)

50) If (-2, 5) is the endpoint of a line segment, and (2, 3) is its midpoint, find the other endpoint. 50) _____
 A) (-10, 9) B) (6, 1) C) (6, 7) D) (-6, 13)

51) If (8, 9) is the endpoint of a line segment, and (4, 12) is its midpoint, find the other endpoint. 51) _____
 A) (0, 15) B) (16, 3) C) (14, 1) D) (0, 6)

52) The medians of a triangle intersect at a point. The distance from the vertex to the point is exactly two-thirds of the distance from the vertex to the midpoint of the opposite side. Find the exact distance of that point from the vertex A(3, 4) of a triangle, given that the other two vertices are at (0, 0) and (8, 0). 52) _____

A) $\frac{\sqrt{17}}{3}$ B) 2 C) $\frac{8}{3}$ D) $\frac{2\sqrt{17}}{3}$

Determine whether the given point is on the graph of the equation.

53) Equation: $y = x^3 - \sqrt{x}$
 Point: (-4, -66) 53) _____

A) No B) Yes

54) Equation: $x^2 + y^2 = 4$

Point: (2, 0) 54) _____

A) No B) Yes

Graph the equation by plotting points.

55) $y = x - 2$

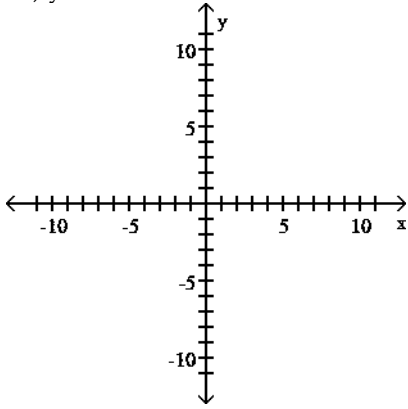

55) _____

A)

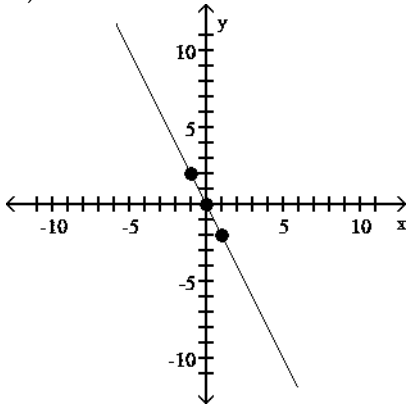

B)

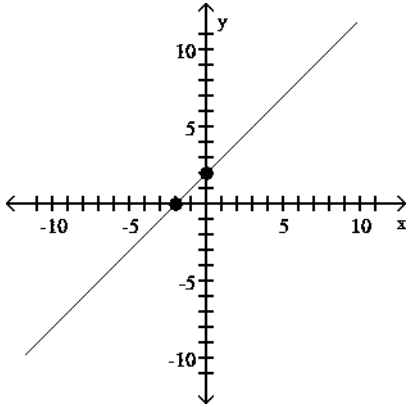

C)

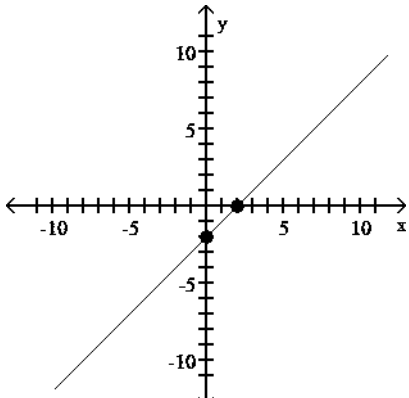

D)

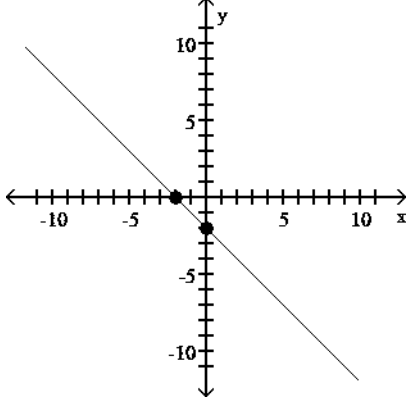

56) $y = 2x - 4$

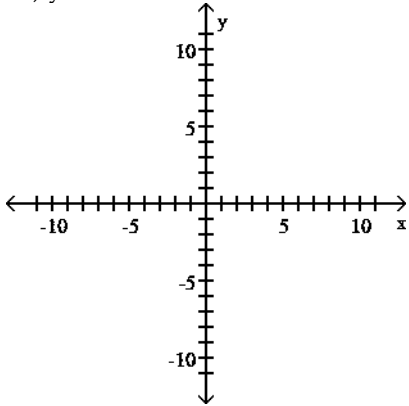

56) _____

A)

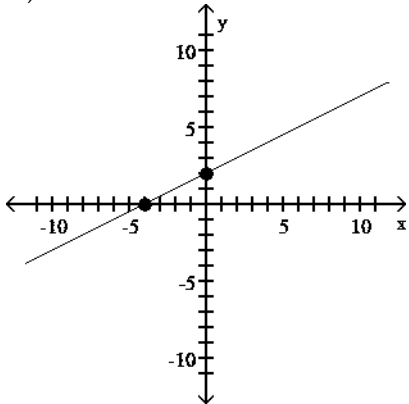

B)

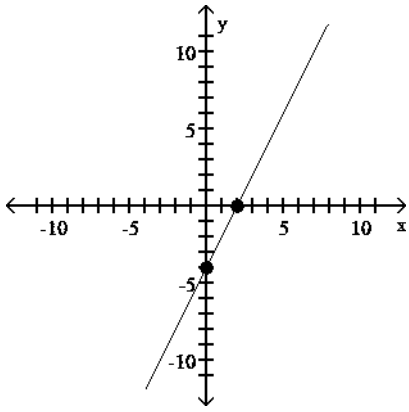

C)

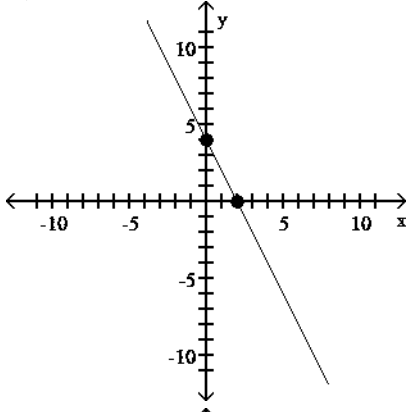

D)

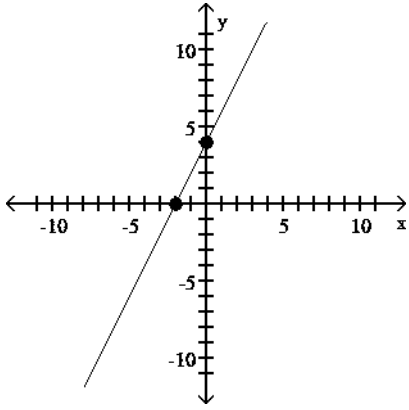

2

57) $y = x^2 - 9$

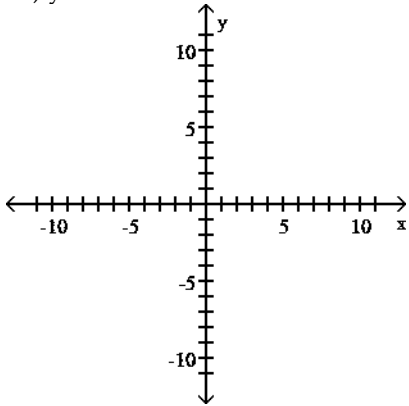

57) _____

A)

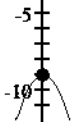
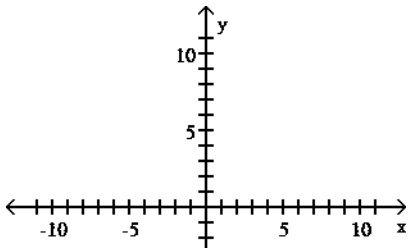

B)

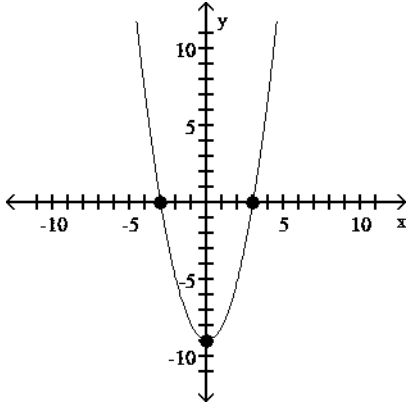

C)

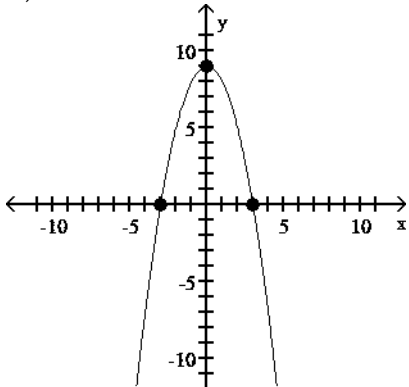

D)

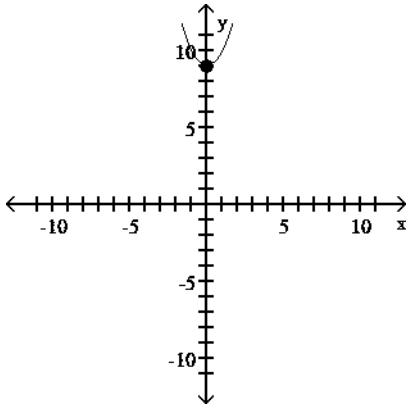

58) $4x + 2y = 8$

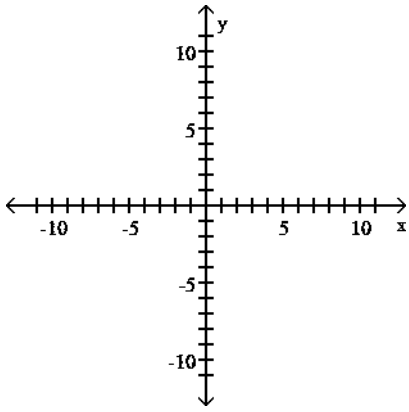

58) _____

A)

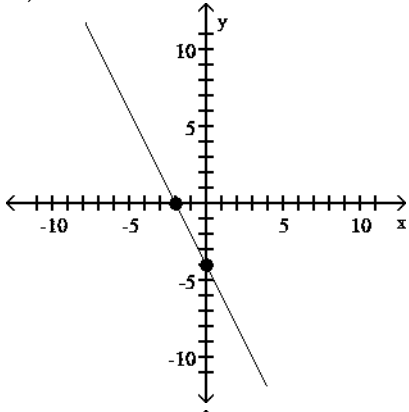

B)

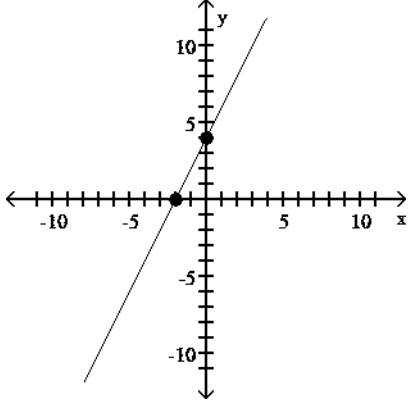

C)

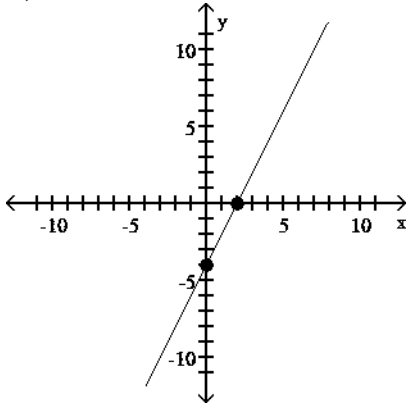

D)

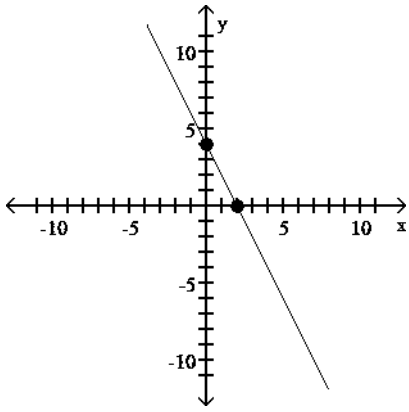

2
59) $4x^2 + y = 4$

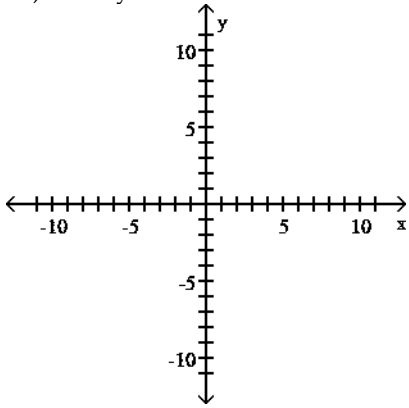

59) _____

A)

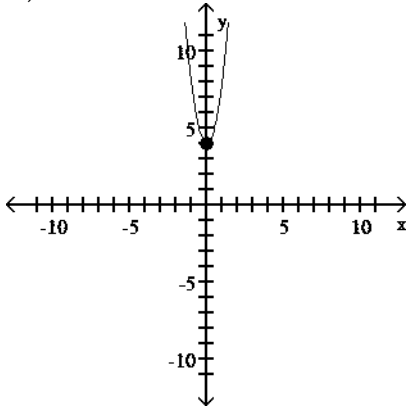

B)

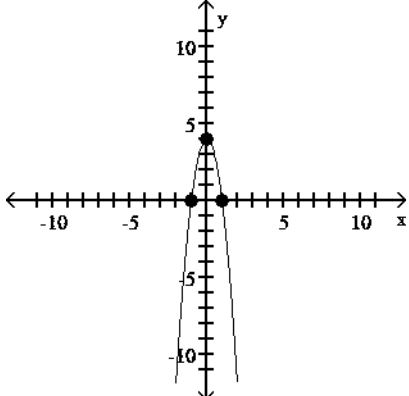

C)

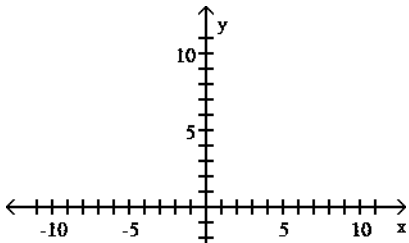

D)

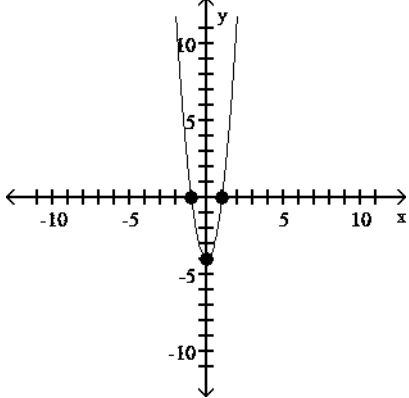

Solve the problem.

60) If $(a, 3)$ is a point on the graph of $y = 2x - 5$, what is a ? 60) _____

- A) -4 B) 1 C) -1 D) 4

61) If $(3, b)$ is a point on the graph of $3x - 2y = 17$, what is b ? 61) _____

- A) $\frac{11}{3}$ B) $\frac{23}{3}$ C) 4 D) -4

62) The height of a baseball (in feet) at time t (in seconds) is given by $y = -16t^2 + 80t + 5$. Which one of the following points is not on the graph of the equation? 62) _____

- A) (4, 69) B) (2, 117) C) (3, 101) D) (1, 69)

List the intercepts of the graph.

63)

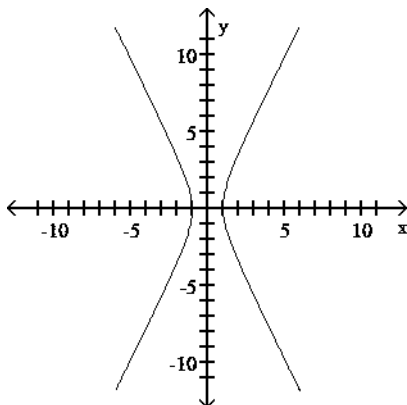

63) _____

A) (-1, 0), (0, 1) B) (0, -1), (1, 0) C) (0, -1), (0, 1) D) (-1, 0), (1, 0)

64)

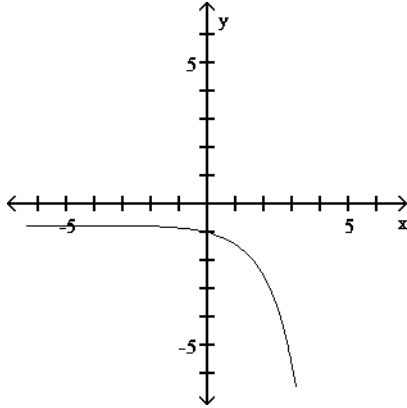

64) _____

A) (0, 0) B) (-1, -1) C) (0, -1) D) (-1, 0)

65)

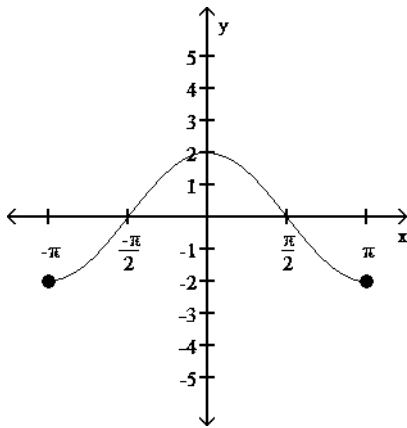

65) _____

A) $\left(0, -\frac{\pi}{2}\right), (2, 0), \left(0, \frac{\pi}{2}\right)$ B) $\left(-\frac{\pi}{2}, 0\right), (2, 0), \left(\frac{\pi}{2}, 0\right)$
 C) $\left(0, -\frac{\pi}{2}\right), (0, 2), \left(0, \frac{\pi}{2}\right)$ D) $\left(-\frac{\pi}{2}, 0\right), (0, 2), \left(\frac{\pi}{2}, 0\right)$

66)

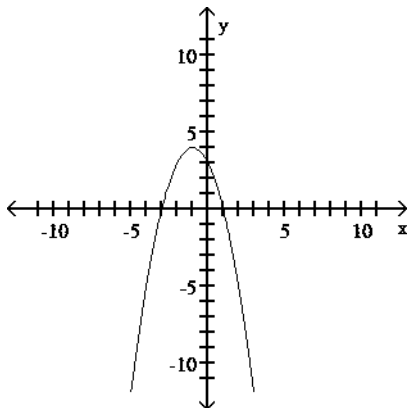

66) _____

- A) $(0, -3), (3, 0), (0, 1)$ B) $(-3, 0), (0, 3), (1, 0)$
 C) $(-3, 0), (0, 3), (0, 1)$ D) $(0, -3), (0, 3), (1, 0)$

67)

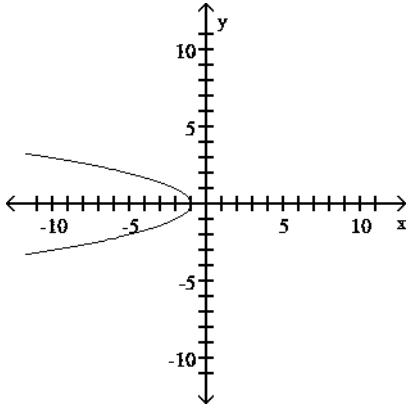

67) _____

- A) $(-1, 0)$ B) $(0, -1)$ C) $(0, 1)$ D) $(1, 0)$

68)

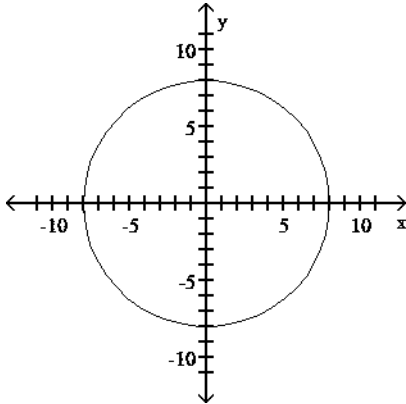

68) _____

- A) $(0, 8), (8, 0)$ B) $(-8, 0), (0, 8)$
 C) $(-8, 0), (0, -8), (0, 0), (0, 8), (8, 0)$ D) $(-8, 0), (0, -8), (0, 8), (8, 0)$

69)

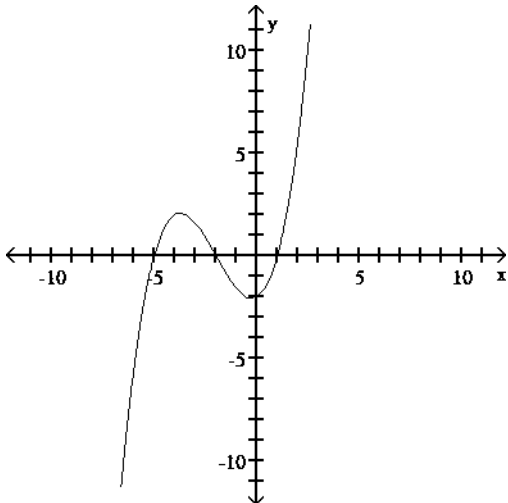

69) _____

- A) (2, 0), (1, 0), (5, 0), (0, -2) B) (-2, 0), (0, -2), (0, 1), (0, -5)
 C) (-2, 0), (0, 2), (0, 1), (0, 5) D) (-2, 0), (1, 0), (-5, 0), (0, -2)

70)

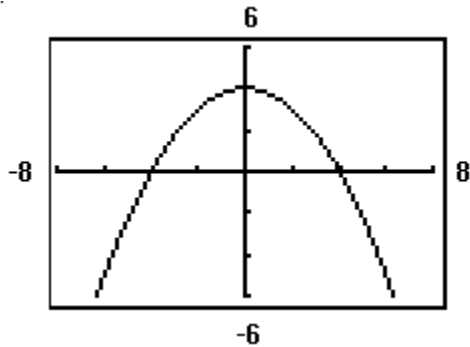

70) _____

- A) (-2, 0), (0, 2), (2, 0) B) (-2, 0), (2, 0)
 C) (-4, 0), (0, 4), (4, 0) D) (-2, 0), (0, 4), (2, 0)

List the intercepts for the graph of the equation.

71) $y = x + 4$ 71) _____

- A) (-4, 0), (0, 4) B) (4, 0), (0, 4) C) (4, 0), (0, -4) D) (-4, 0), (0, -4)

72) $y = -4x$ 72) _____

- A) (-4, 0) B) (0, -4) C) (-4, -4) D) (0, 0)

73) $y^2 = x + 1$ 73) _____

- A) (0, -1), (-1, 0), (0, 1) B) (-1, 0), (0, -1), (1, 0)
 C) (1, 0), (0, 1), (0, -1) D) (0, -1), (1, 0), (0, 1)

74) $y = \sqrt[6]{x}$ 74) _____

- A) (1, 1) B) (1, 0) C) (0, 1) D) (0, 0)

75) $x^2 + y - 4 = 0$ 75) _____

- A) (-2, 0), (0, 4), (2, 0) B) (-2, 0), (0, -4), (2, 0)
 C) (2, 0), (0, 4), (0, -4) D) (0, -2), (4, 0), (0, 2)

76) $4x^2 + 16y^2 = 64$ 76) _____

- A) (-4, 0), (0, -2), (0, 2), (4, 0) B) (-4, 0), (-16, 0), (16, 0), (4, 0)
 C) (-2, 0), (-4, 0), (4, 0), (2, 0) D) (-16, 0), (0, -4), (0, 4), (16, 0)

77) $9x^2 + y^2 = 9$ 77) _____

- A) (-1, 0), (0, -9), (0, 9), (1, 0) B) (-3, 0), (0, -1), (0, 1), (3, 0)
 C) (-9, 0), (0, -1), (0, 1), (9, 0) D) (-1, 0), (0, -3), (0, 3), (1, 0)

78) $y = x^3 - 64$ 78) _____

- A) (0, -4), (-4, 0) B) (0, -64), (4, 0) C) (0, -4), (0, 4) D) (-64, 0), (0, 4)

79) $y = x^4 - 16$ 79) _____

- A) (0, 16), (-2, 0), (2, 0) B) (0, -16)
 C) (0, 16) D) (0, -16), (-2, 0), (2, 0)

- 80) $y = x^2 + 12x + 32$ 80) _____
 A) (-8, 0), (-4, 0), (0, 32) B) (0, 8), (0, 4), (32, 0)
 C) (0, -8), (0, -4), (32, 0) D) (8, 0), (4, 0), (0, 32)

- 81) $y = x^2 + 4$ 81) _____
 A) (0, 4) B) (4, 0)
 C) (0, 4), (-2, 0), (2, 0) D) (4, 0), (0, -2), (0, 2)

- 82) $y = \frac{6x}{x^2 + 36}$ 82) _____
 A) (-6, 0), (0, 0), (6, 0) B) (0, 0)
 C) (0, -6), (0, 0), (0, 6) D) (-36, 0), (0, 0), (36, 0)

- 83) $y = \frac{x^2 - 64}{8x^4}$ 83) _____

- A) (0, 0) B) (-8, 0), (8, 0)
 C) (0, -8), (0, 8) D) (-64, 0), (0, 0), (64, 0)

Plot the point A. Plot the point B that has the given symmetry with point A.

- 84) A = (5, 1); B is symmetric to A with respect to the origin

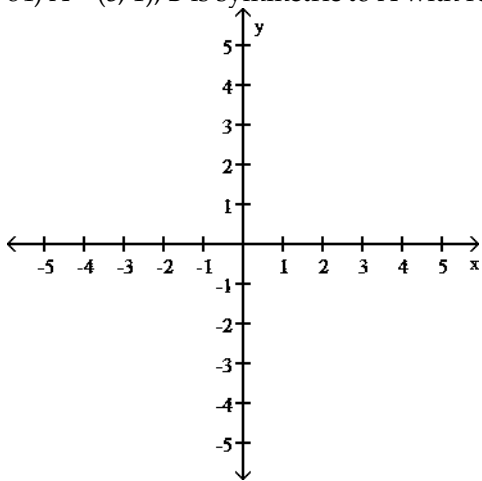

84) _____

- A)

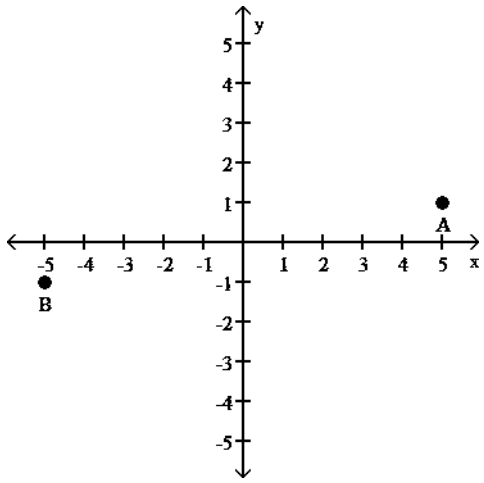

B)

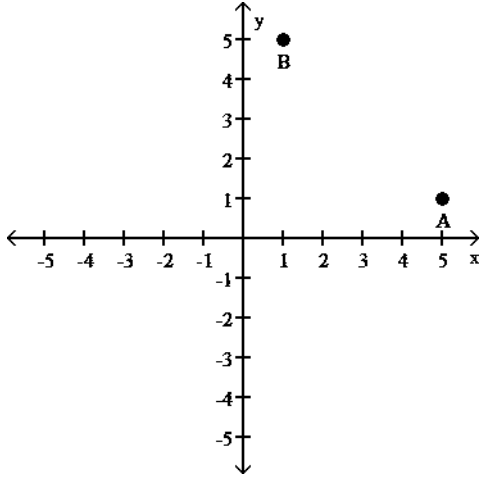

C)

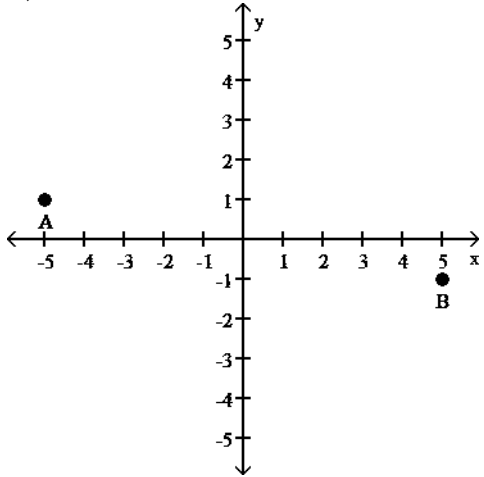

D)

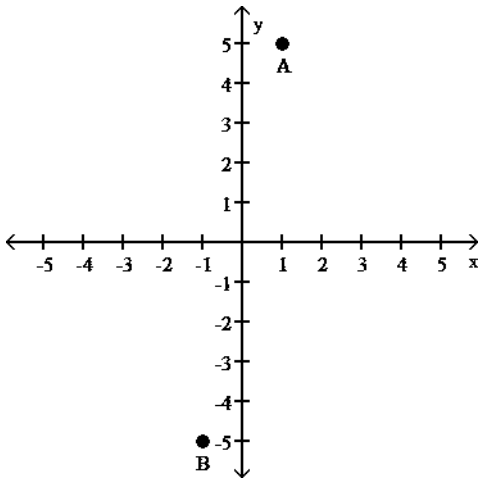

85) $A = (0, 1)$; B is symmetric to A with respect to the origin

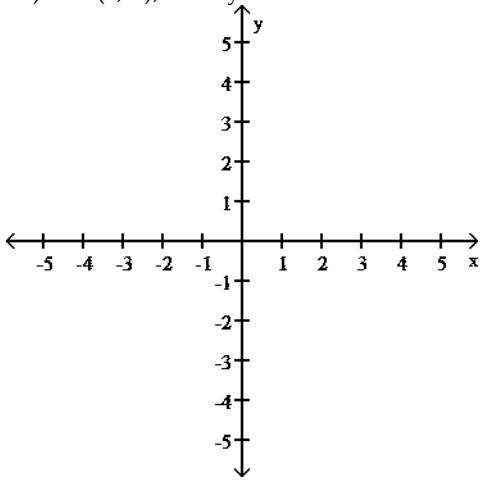

85) _____

A)

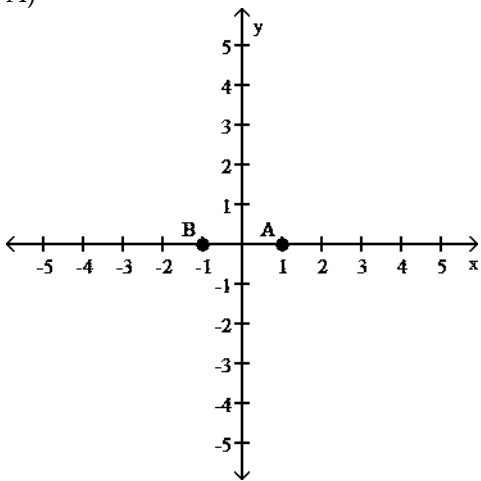

B)

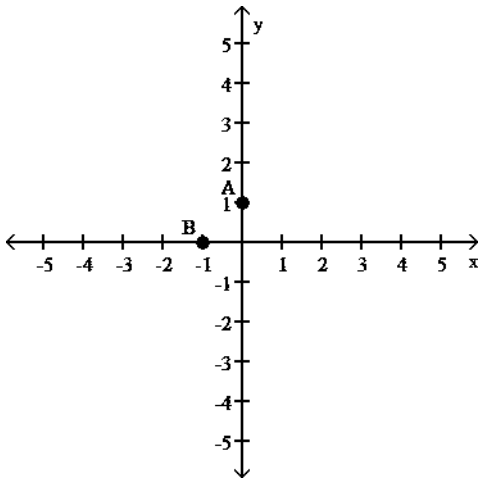

C)

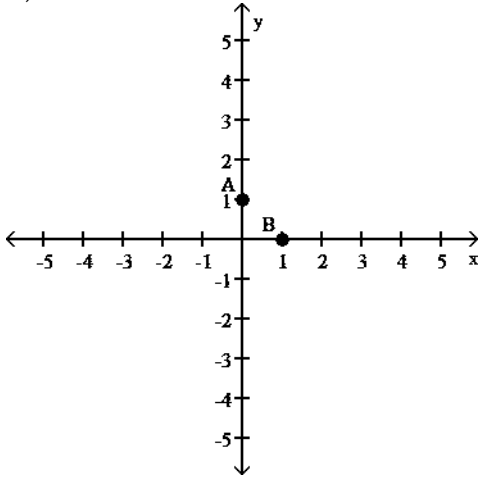

D)

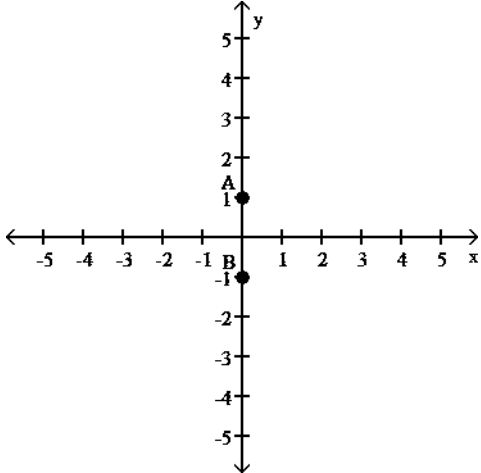

List the intercepts of the graph. Tell whether the graph is symmetric with respect to the x-axis, y-axis, origin, or none of these.

86)

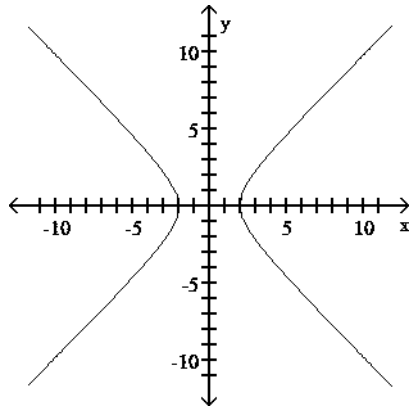

86) _____

- A) intercepts: $(0, -2)$ and $(0, 2)$
symmetric with respect to x-axis, y-axis, and origin
- B) intercepts: $(-2, 0)$ and $(2, 0)$
symmetric with respect to x-axis, y-axis, and origin
- C) intercepts: $(0, -2)$ and $(0, 2)$
symmetric with respect to y-axis
- D) intercepts: $(-2, 0)$ and $(2, 0)$
symmetric with respect to origin

87)

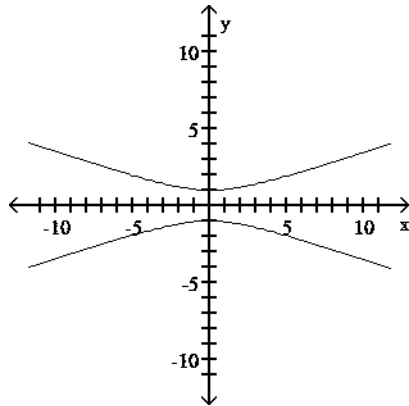

87) _____

- A) intercepts: $(1, 0)$ and $(-1, 0)$
symmetric with respect to y-axis
- B) intercepts: $(0, 1)$ and $(0, -1)$
symmetric with respect to origin
- C) intercepts: $(1, 0)$ and $(-1, 0)$
symmetric with respect to x-axis, y-axis, and origin
- D) intercepts: $(0, 1)$ and $(0, -1)$
symmetric with respect to x-axis, y-axis, and origin

88)

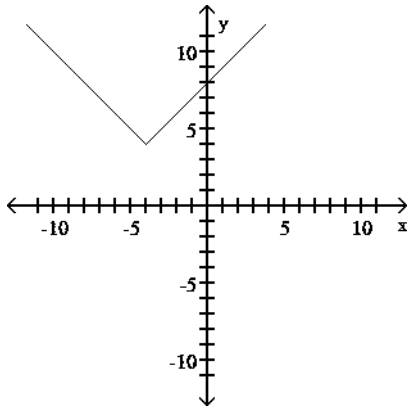

88) _____

- A) intercept: (0, 8)
symmetric with respect to x-axis
- B) intercept: (8, 0)
no symmetry
- C) intercept: (0, 8)
no symmetry
- D) intercept: (8, 0)
symmetric with respect to y-axis

89)

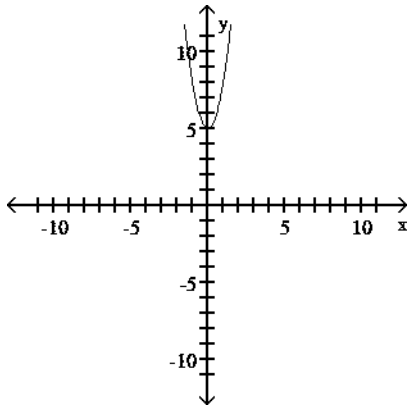

89) _____

- A) intercept: (5, 0)
symmetric with respect to x-axis
- B) intercept: (0, 5)
symmetric with respect to y-axis
- C) intercept: (0, 5)
symmetric with respect to origin
- D) intercept: (5, 0)
symmetric with respect to y-axis

90)

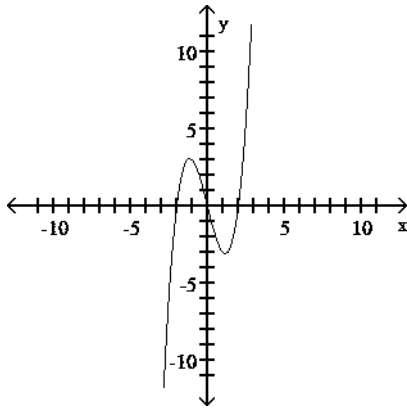

90) _____

- A) intercepts: $(-2, 0)$, $(0, 0)$, $(2, 0)$
symmetric with respect to x-axis, y-axis, and origin
- B) intercepts: $(-2, 0)$, $(0, 0)$, $(2, 0)$
symmetric with respect to y-axis
- C) intercepts: $(-2, 0)$, $(0, 0)$, $(2, 0)$
symmetric with respect to x-axis
- D) intercepts: $(-2, 0)$, $(0, 0)$, $(2, 0)$
symmetric with respect to origin

Draw a complete graph so that it has the given type of symmetry.

91) Symmetric with respect to the y-axis

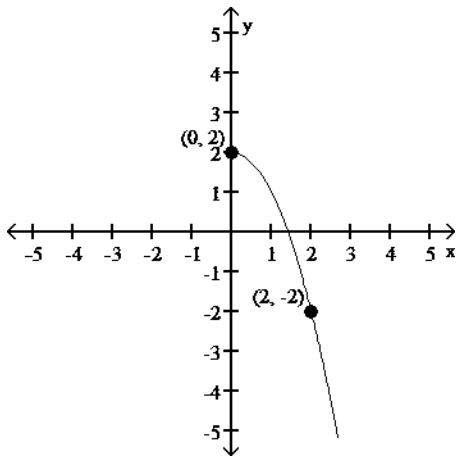

91) _____

A)

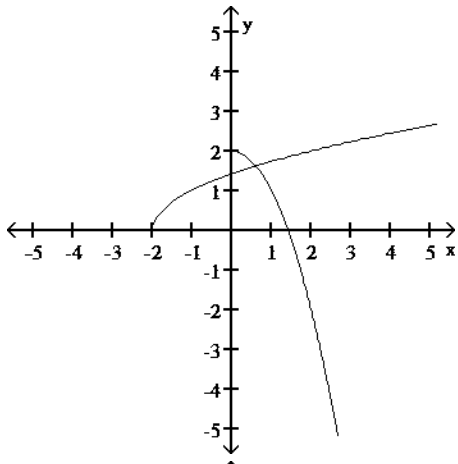

B)

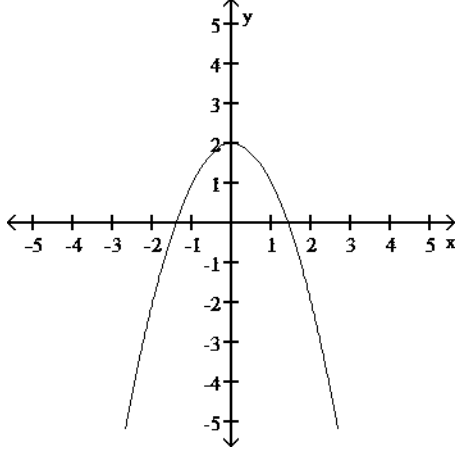

C)

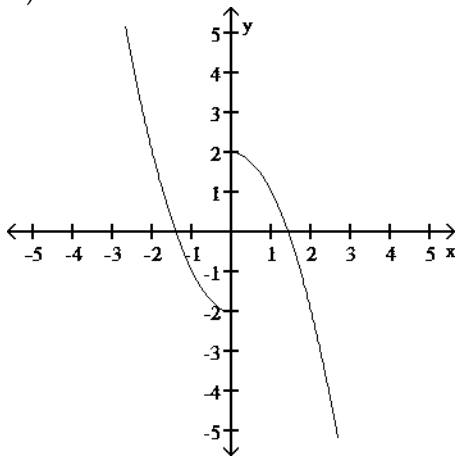

D)

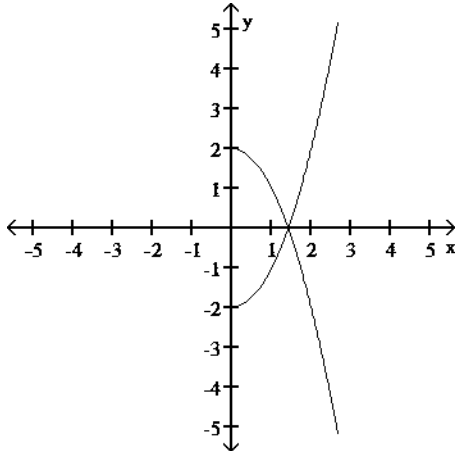

92) origin

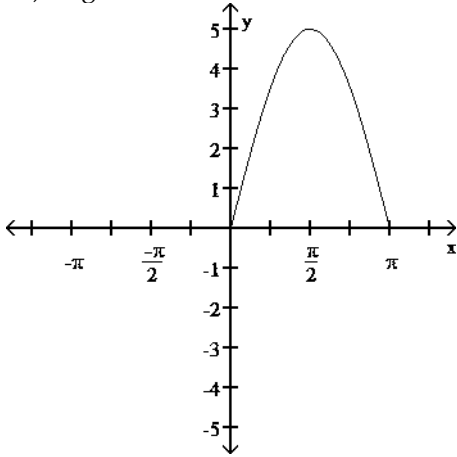

92) _____

A)

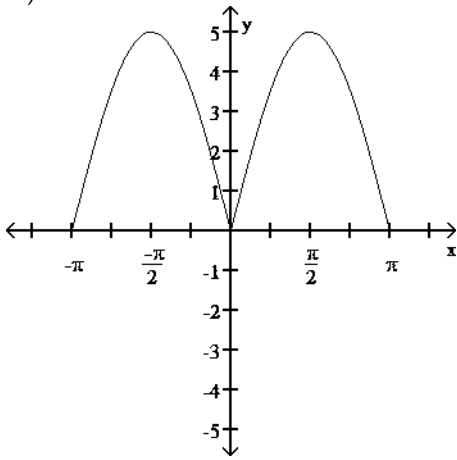

B)

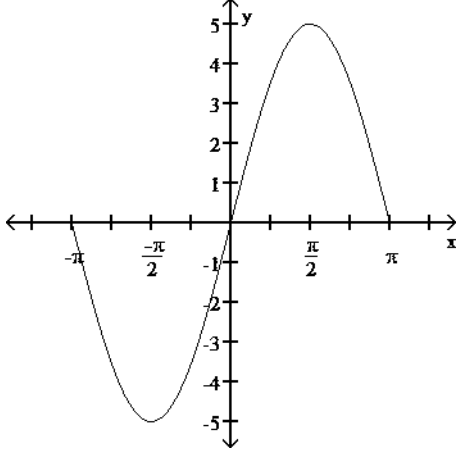

C)

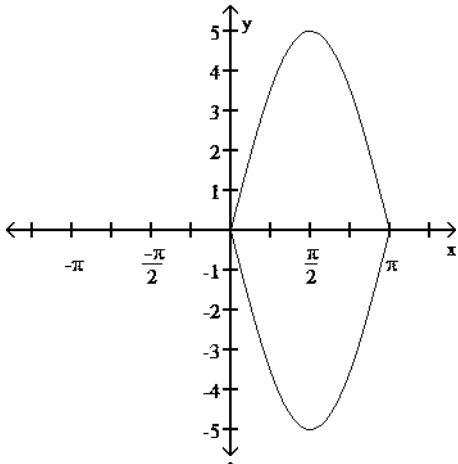

D)

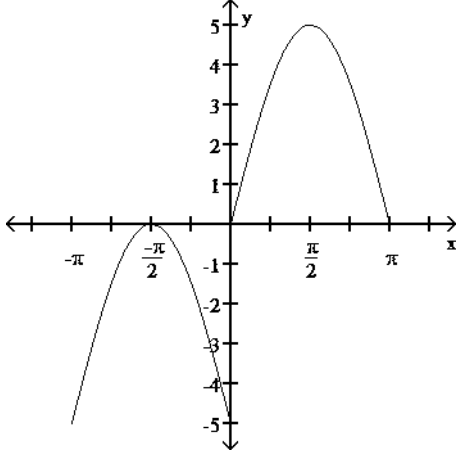

93) Symmetric with respect to the x-axis

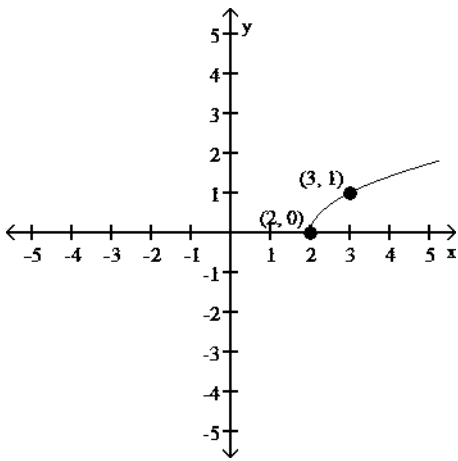

93) _____

A)

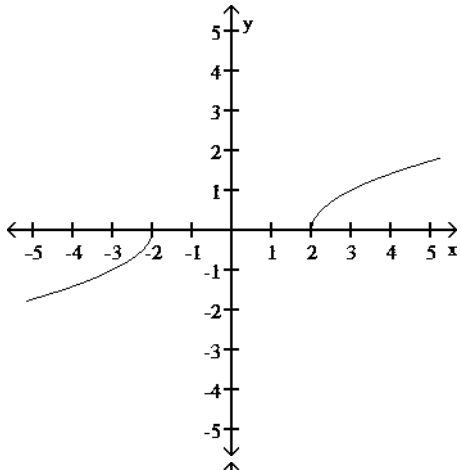

B)

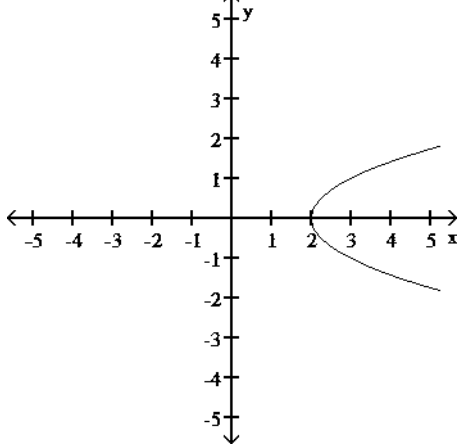

C)

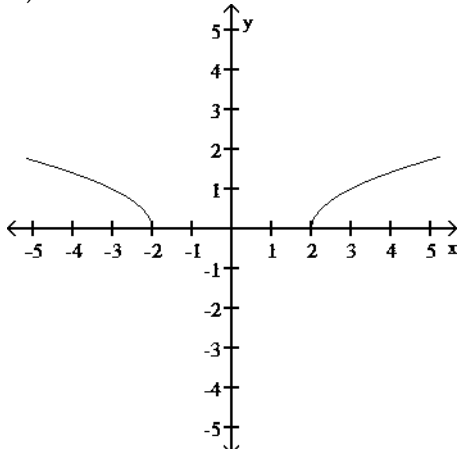

D)

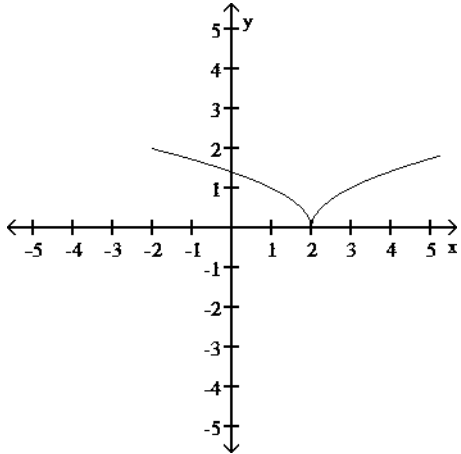

List the intercepts and type(s) of symmetry, if any.

94) $y^2 = x + 1$ 94) _____

A) intercepts: (0, 1), (1, 0), (-1, 0)

symmetric with respect to y-axis B) intercepts: (1, 0), (0, 1), (0, -1)

symmetric with respect to x-axis

C) intercepts: (-1, 0), (0, 1), (0, -1)

symmetric with respect to x-axis D) intercepts: (0, -1), (1, 0), (-1, 0)

symmetric with respect to y-axis

95) $16x^2 + y^2 = 16$ 95) _____

A) intercepts: (4, 0), (-4, 0), (0, 1), (0, -1)

symmetric with respect to x-axis and y-axis

B) intercepts: (4, 0), (-4, 0), (0, 1), (0, -1)

symmetric with respect to the origin

C) intercepts: (1, 0), (-1, 0), (0, 4), (0, -4)

symmetric with respect to x-axis and y-axis

D) intercepts: (1, 0), (-1, 0), (0, 4), (0, -4)

symmetric with respect to x-axis, y-axis, and origin

96) $y = \frac{-x^5}{x^2 - 9}$ 96) _____

A) intercept: (0, 0)

symmetric with respect to x-axis B) intercepts: (3, 0), (-3, 0), (0, 0)

symmetric with respect to origin

C) intercept: (0, 0)

symmetric with respect to y-axis D) intercept: (0, 0)

symmetric with respect to origin

Determine whether the graph of the equation is symmetric with respect to the x-axis, the y-axis, and/or the origin.

97) $y = x - 1$ 97) _____

A) y-axis

B) origin

C) x-axis

D) x-axis, y-axis, origin

E) none

98) $y = 2x$ 98) _____

A) x-axis

B) y-axis

C) origin

D) x-axis, y-axis, origin

E) none

99) $x^2 + y - 36 = 0$ 99) _____

A) x-axis

B) origin

C) y-axis

D) x-axis, y-axis, origin

E) none

100) $y^2 - x - 25 = 0$ 100) _____

- A) origin
- B) x-axis
- C) y-axis
- D) x-axis, y-axis, origin
- E) none

101) $4x^2 + 16y^2 = 64$ 101) _____

- A) y-axis
- B) origin
- C) x-axis
- D) x-axis, y-axis, origin
- E) none

102) $9x^2 + y^2 = 9$ 102) _____

- A) x-axis
- B) origin
- C) y-axis
- D) x-axis, y-axis, origin
- E) none

103) $y = x^2 + 15x + 56$ 103) _____

- A) origin
- B) x-axis
- C) y-axis
- D) x-axis, y-axis, origin
- E) none

104) $y = \frac{5x}{x^2 + 25}$ 104) _____

- A) y-axis
- B) x-axis
- C) origin
- D) x-axis, y-axis, origin
- E) none

105) $y = \frac{x^2 - 49}{7x^4}$ 105) _____

- A) x-axis
- B) y-axis
- C) origin
- D) x-axis, y-axis, origin
- E) none

106) $y = 2x^2 - 1$ 106) _____

- A) origin
- B) y-axis
- C) x-axis

- D) x-axis, y-axis, origin
- E) none

107) $y = (x - 9)(x + 4)$ 107) _____

- A) y-axis
- B) origin
- C) x-axis
- D) x-axis, y-axis, origin
- E) none

108) $y = -8x^3 + 4x$ 108) _____

- A) y-axis
- B) x-axis
- C) origin
- D) x-axis, y-axis, origin
- E) none

109) $y = -7x^4 + 7x + 9$ 109) _____

- A) x-axis
- B) y-axis
- C) origin
- D) x-axis, y-axis, origin
- E) none

Solve the problem.

110) If a graph is symmetric with respect to the y-axis and it contains the point (5, -6), which of the following points is also on the graph? 110) _____

- A) (-6, 5)
- B) (5, -6)
- C) (-5, 6)
- D) (-5, -6)

111) If a graph is symmetric with respect to the origin and it contains the point (-4, 7), which of the following points is also on the graph? 111) _____

- A) (4, -7)
- B) (4, 7)
- C) (-4, -7)
- D) (7, -4)

Graph the equation by plotting points.

112) $y = x^3$

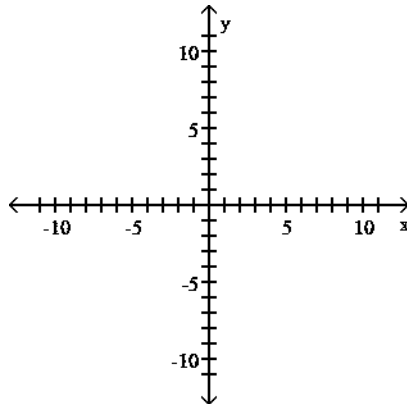

112) _____

- A)

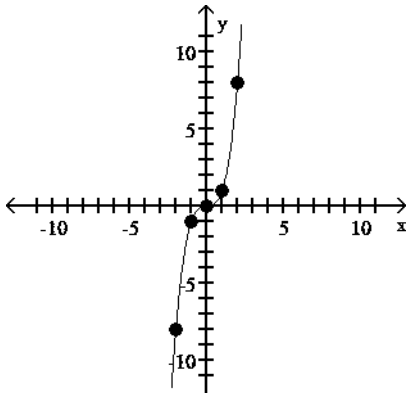

B)

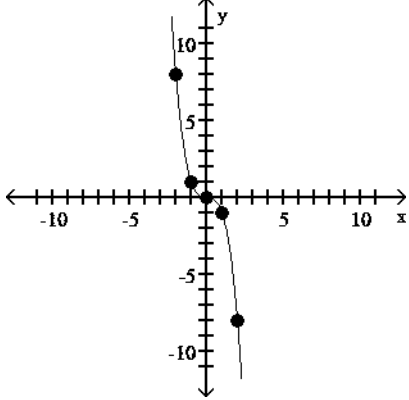

C)

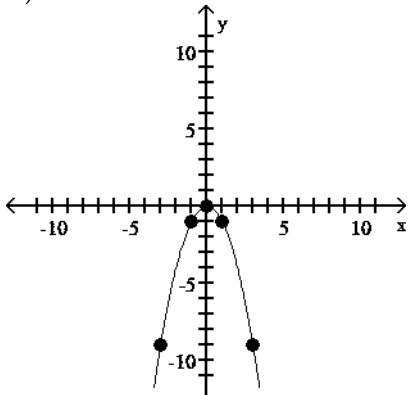

D)

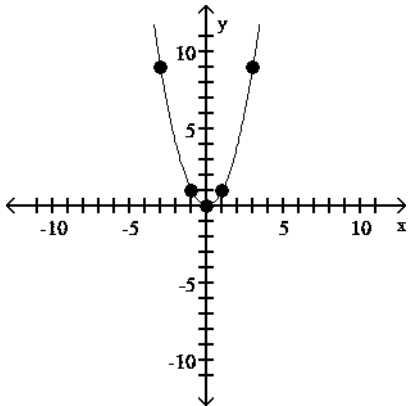

113) $x = y^2$

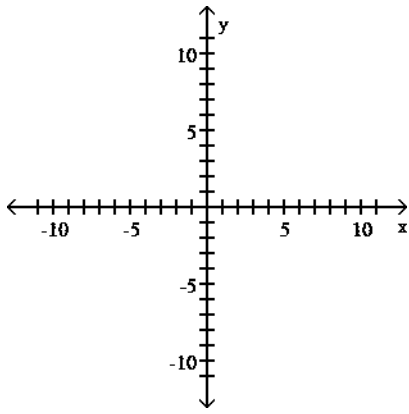

113) _____

A)

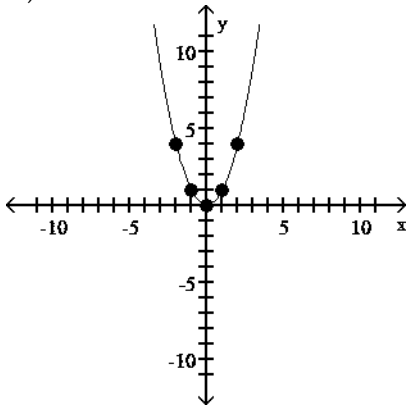

B)

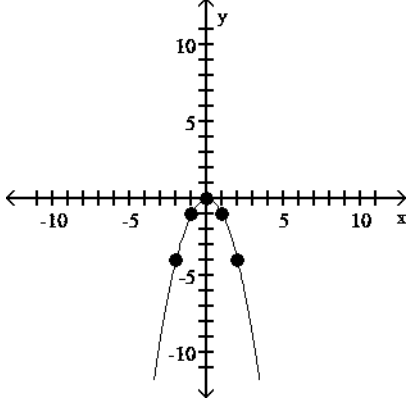

C)

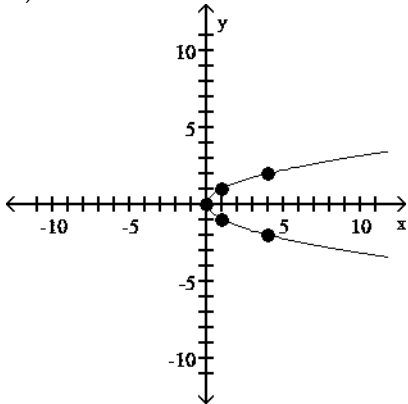

D)

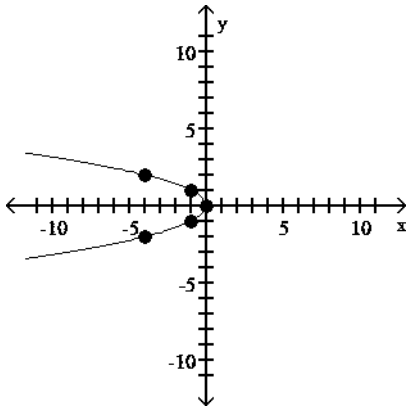

114) $y = \sqrt{x}$

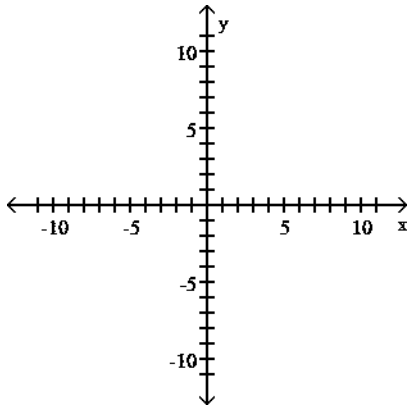

114) _____

A)

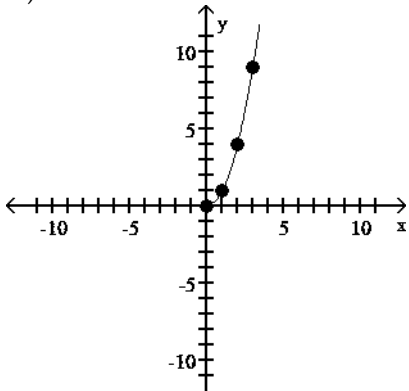

B)

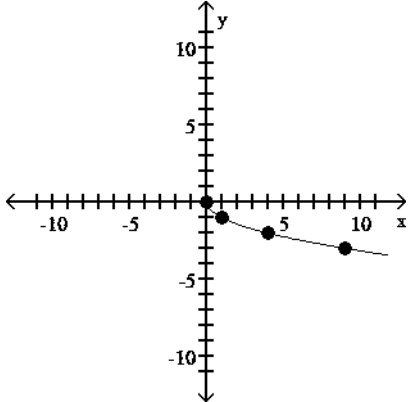

C)

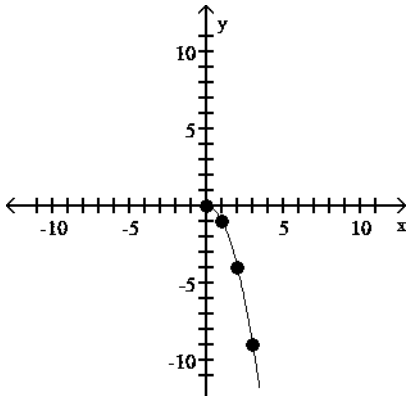

D)

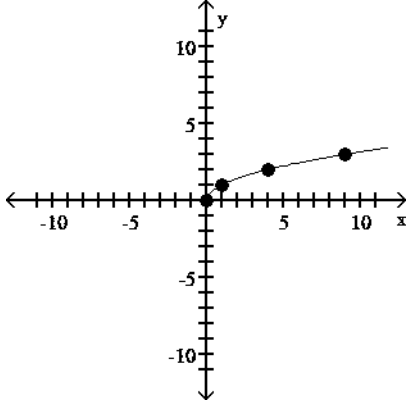

115) $y = \frac{1}{x}$

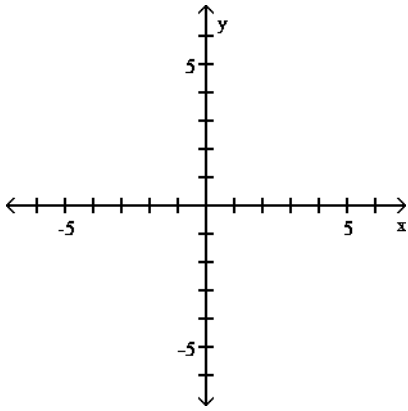

115) _____

A)

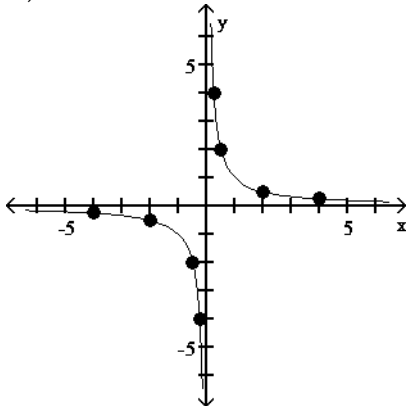

B)

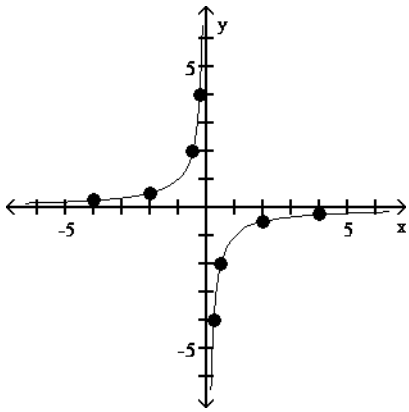

C)

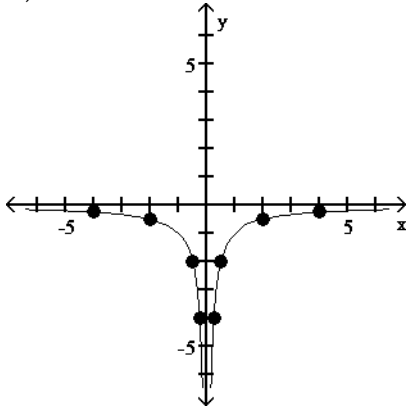

D)

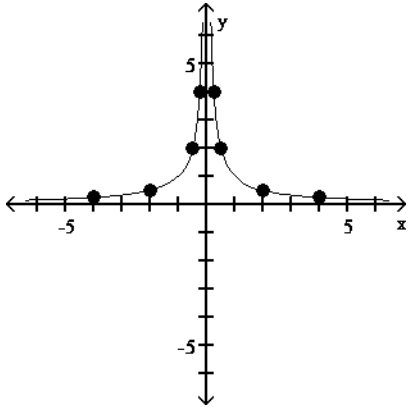

Find the slope of the line through the points and interpret the slope.

116)

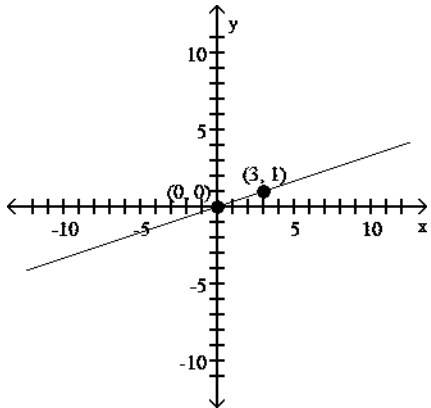

116) _____

- A) $-\frac{1}{3}$; for every 3-unit increase in x , y will decrease by 1 unit
 B) 3; for every 1-unit increase in x , y will increase by 3 units
 C) $\frac{1}{3}$; for every 3-unit increase in x , y will increase by 1 unit
 D) -3; for every 1-unit increase in x , y will decrease by 3 units

Find the slope of the line.

117)

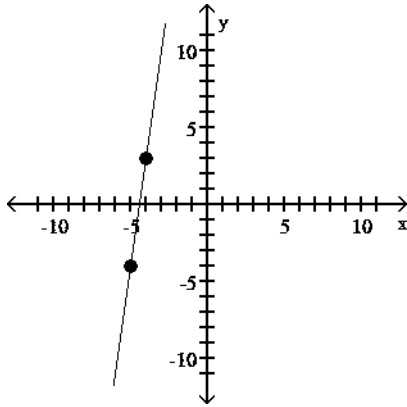

117) _____

- A) $-\frac{1}{7}$ B) $\frac{1}{7}$ C) 7 D) -7

118)

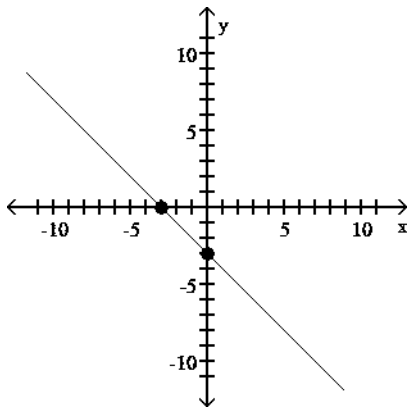

118) _____

- A) 1 B) -3 C) -1 D) 3

119)

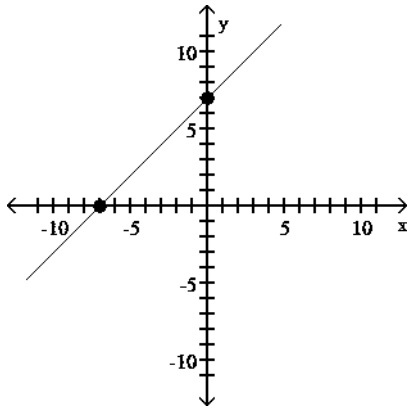

119) _____

- A) 7 B) 1 C) -1 D) -7

120)

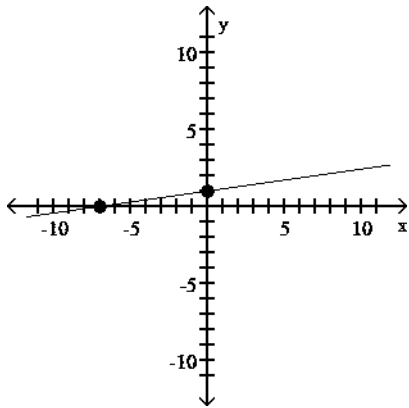

120) _____

- A) $-\frac{1}{7}$ B) -7 C) $\frac{1}{7}$ D) 7

Find the slope of the line containing the two points.

121) (4, -9); (-3, 6) 121) _____

- A) $\frac{15}{7}$ B) $\frac{7}{15}$ C) $-\frac{7}{15}$ D) $-\frac{15}{7}$

122) (8, 0); (0, 5) 122) _____

- A) $-\frac{8}{5}$ B) $\frac{8}{5}$ C) $\frac{5}{8}$ D) $-\frac{5}{8}$

123) (-3, -4); (-6, -5) 123) _____

- A) $-\frac{1}{3}$ B) -3 C) 3 D) $\frac{1}{3}$

124) (-3, -2); (-3, -1) 124) _____

- A) -1 B) 1 C) 0 D) undefined

125) (-8, -3); (4, -3) 125) _____

- A) $-\frac{1}{12}$ B) 0 C) 12 D) undefined

Graph the line containing the point P and having slope m.

126) $P = (4, 6)$; $m = -\frac{13}{4}$

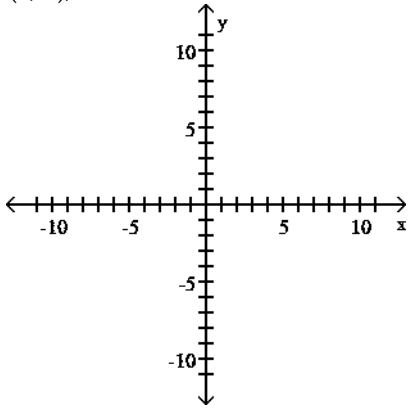

126) _____

A)

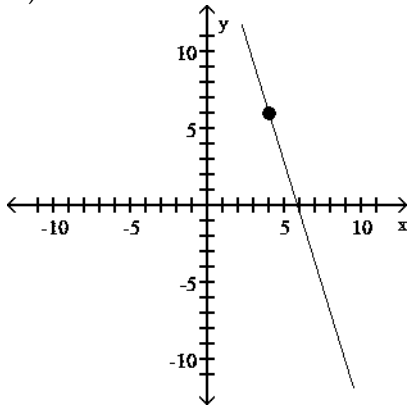

B)

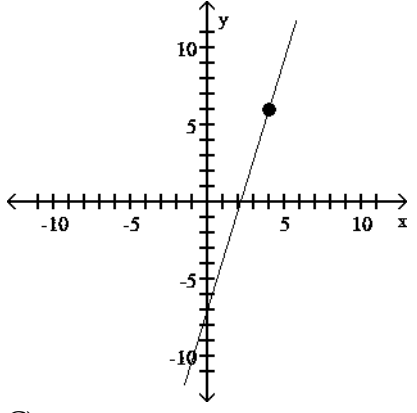

C)

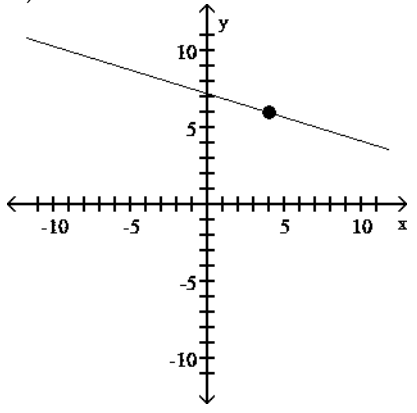

D)

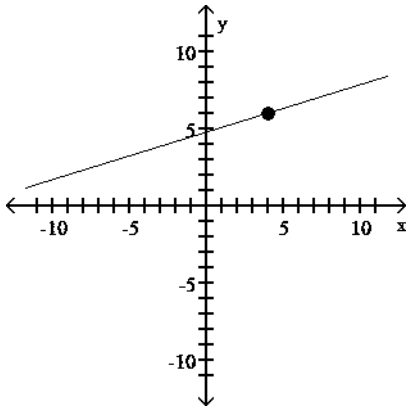

127) $P = (-5, -8)$; $m = 2$

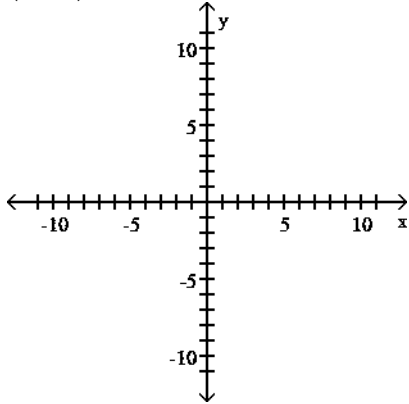

127) _____

A)

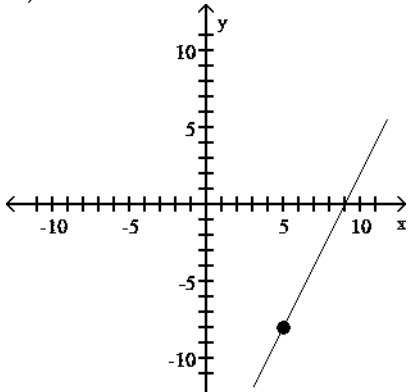

B)

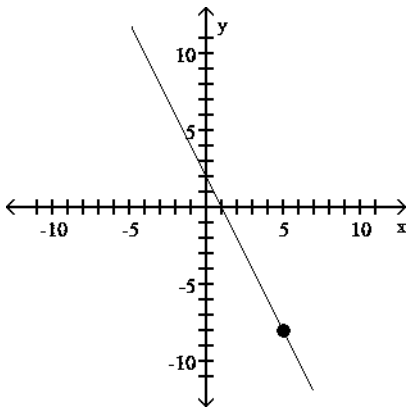

C)

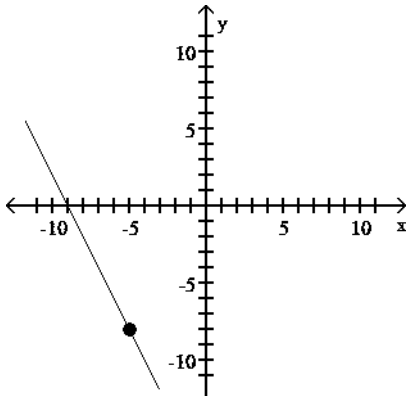

D)

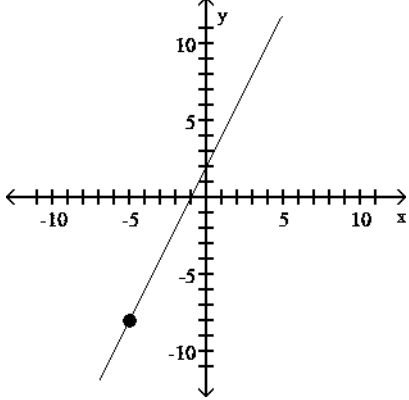

128) $P = (-3, -10); m = -\frac{1}{2}$

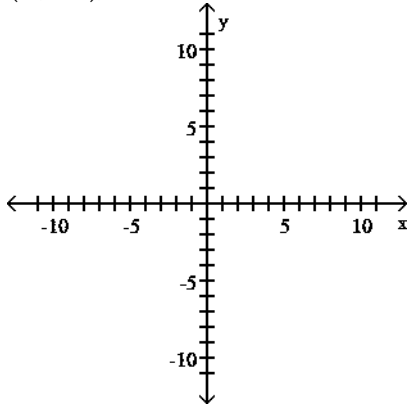

128) _____

A)

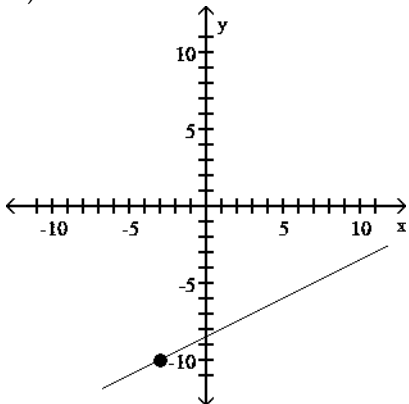

B)

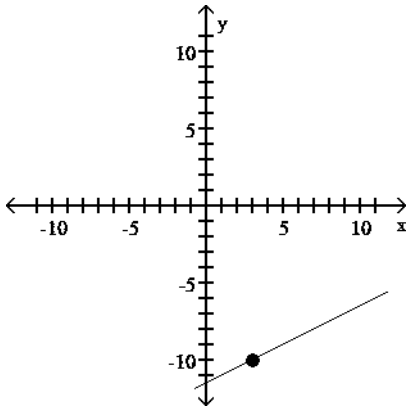

C)

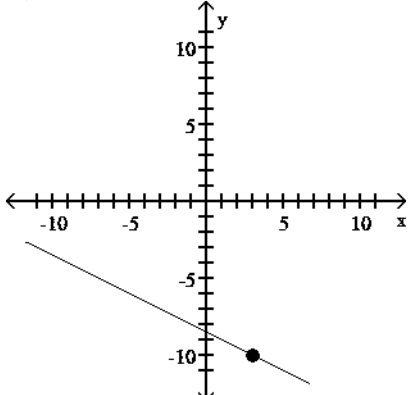

D)

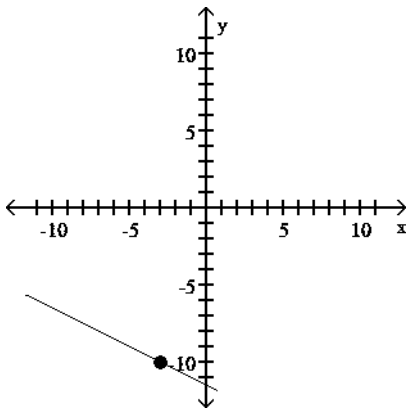

129) $P = (0, 5); m = 1$

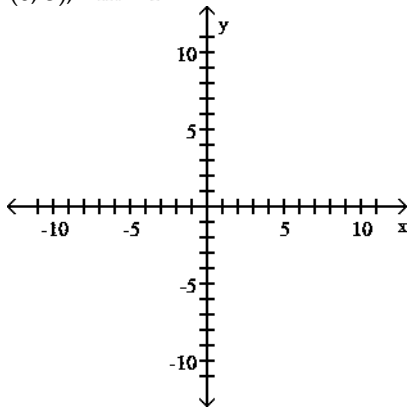

129) _____

A)

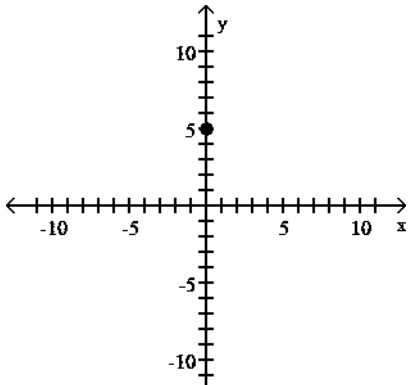

B)

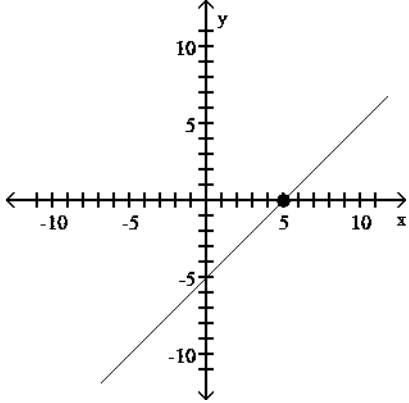

C)

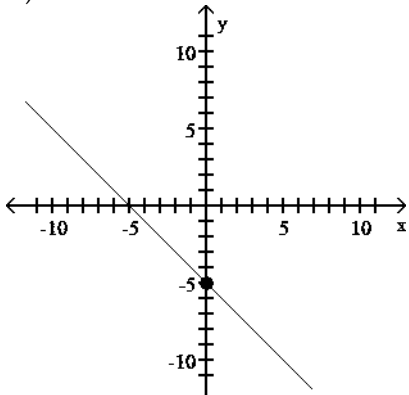

D)

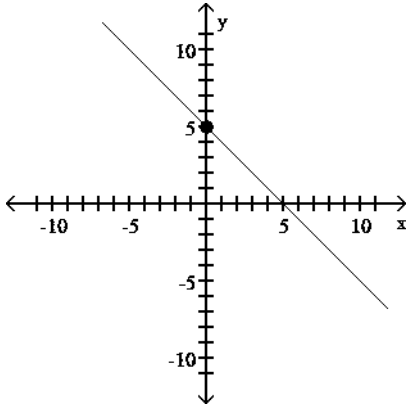

130) $P = (0, 2)$; $m = -\frac{1}{2}$

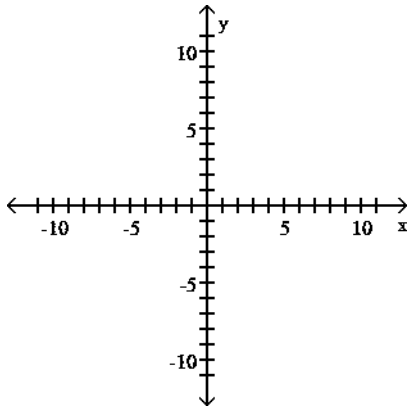

130) _____

A)

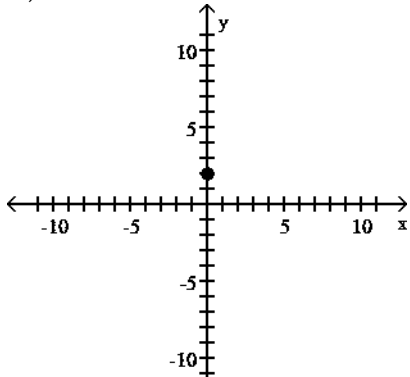

B)

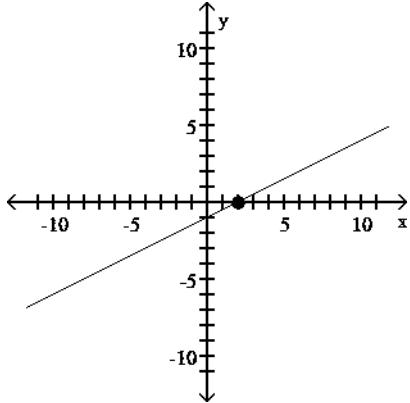

C)

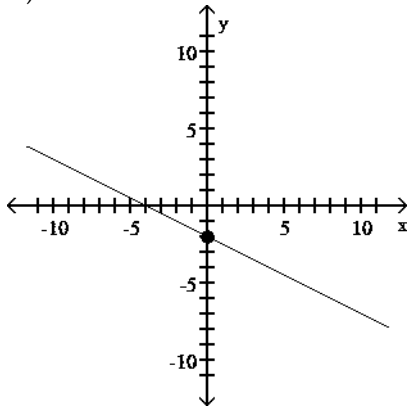

D)

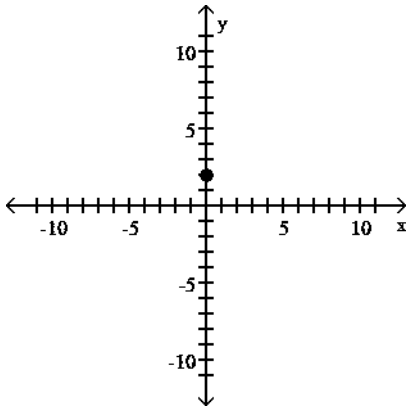

131) $P = (-4, 0)$; $m = 2$

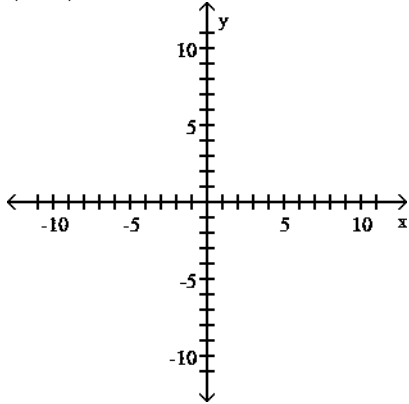

131) _____

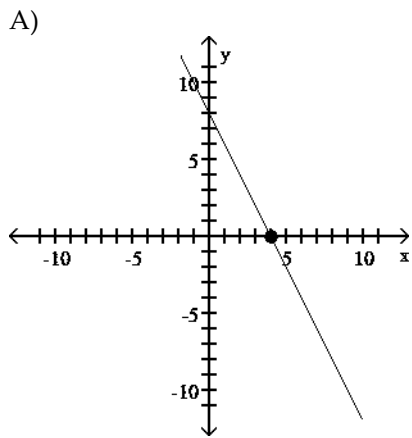

B)

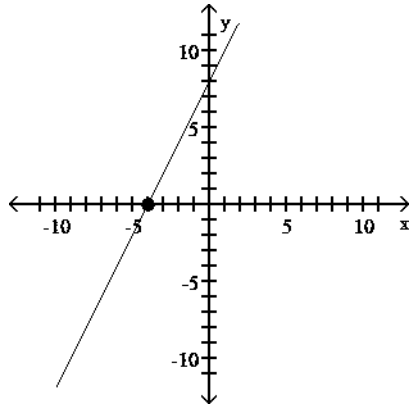

C)

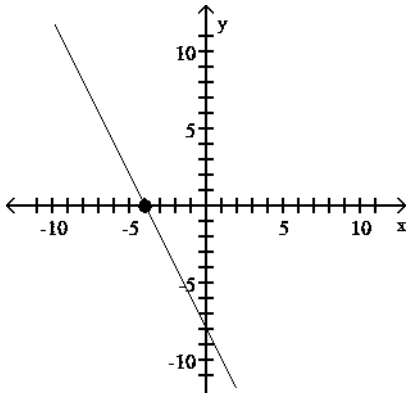

D)

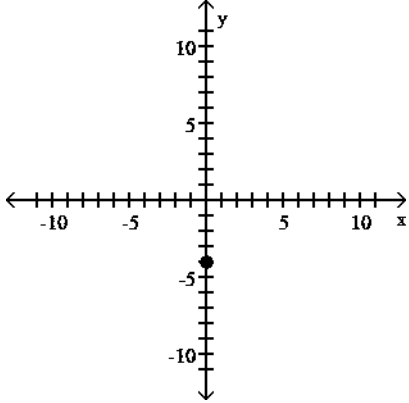

132) $P = (6, 0)$; $m = -2$

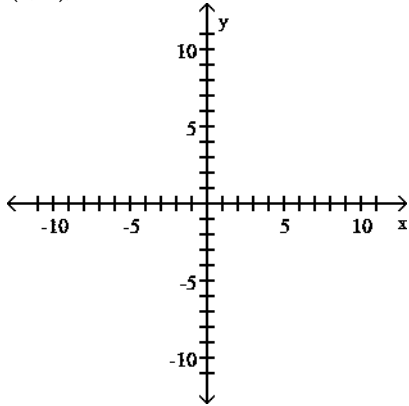

132) _____

A)

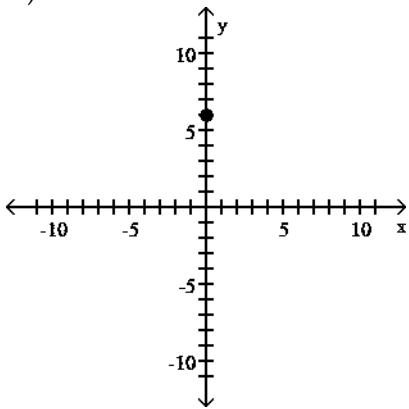

B)

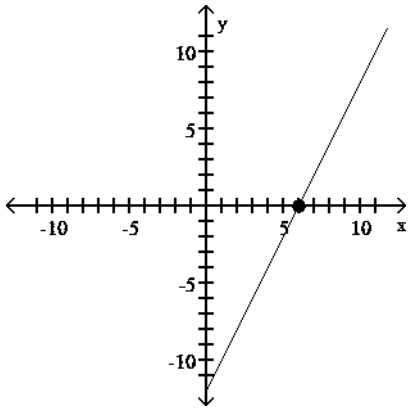

C)

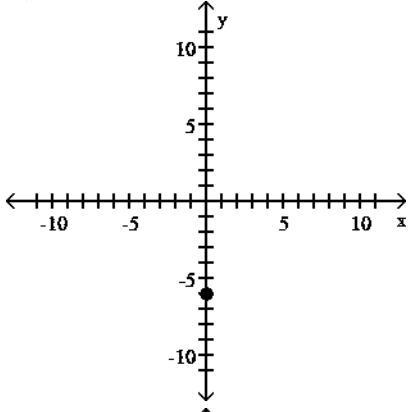

D)

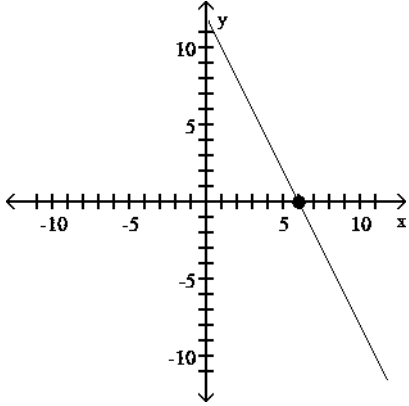

133) $P = (6, 9)$; $m = 0$

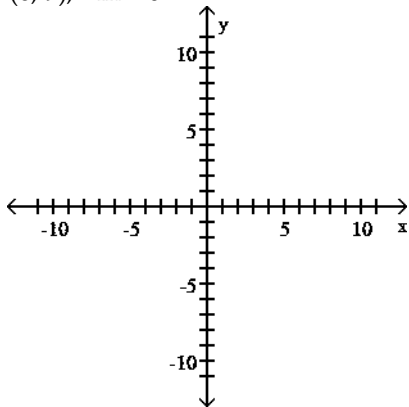

133) _____

A)

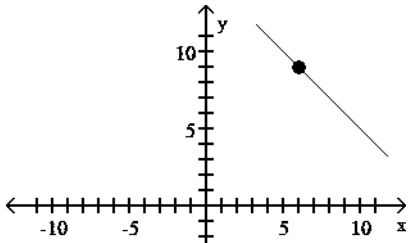

B)

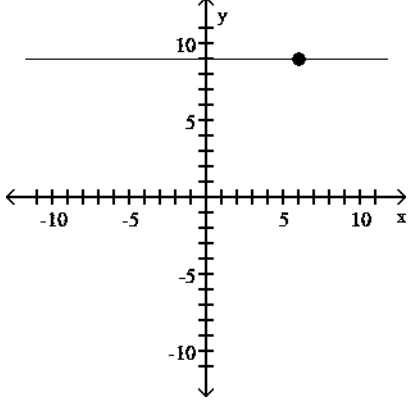

C)

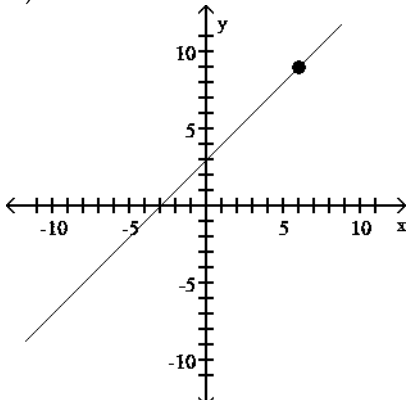

D)

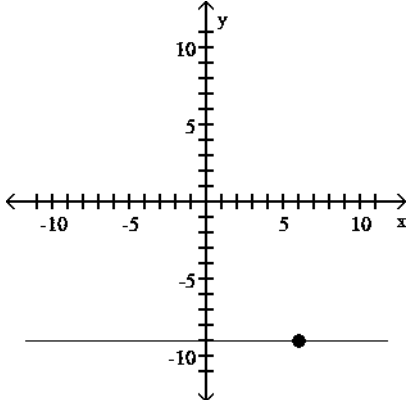

134) $P = (-1, -10)$; slope undefined

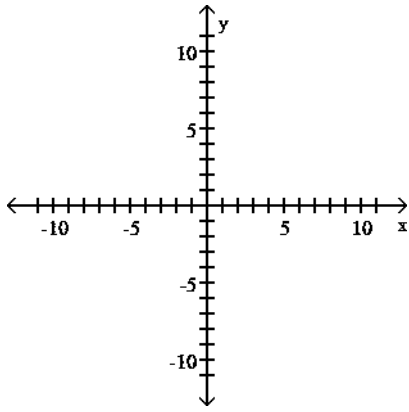

134) _____

A)

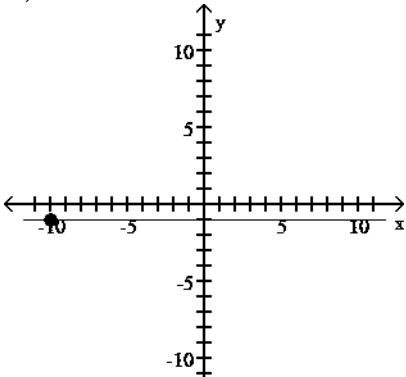

B)

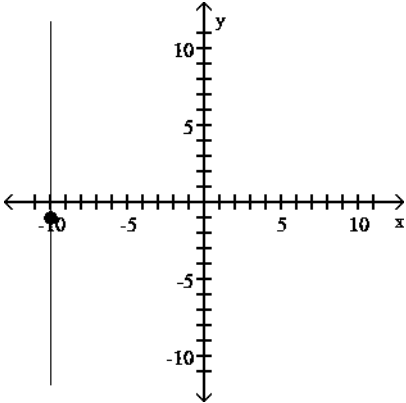

C)

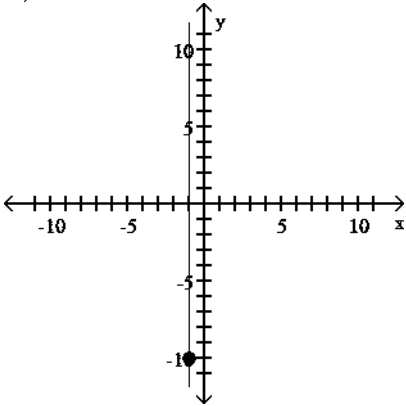

D)

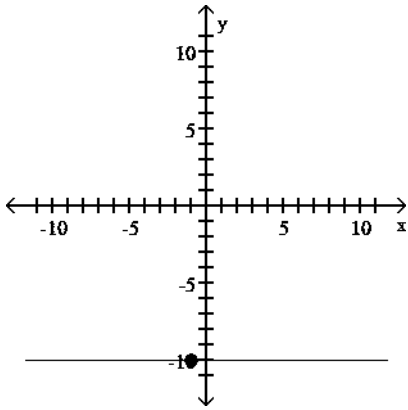

Find an equation for the line with the given properties.

135) Slope undefined; containing the point $(-5, -6)$ 135) _____

A) $x = -6$ B) $y = -6$ C) $x = -5$ D) $y = -5$

136) Vertical line; containing the point $(1, -2)$ 136) _____

A) $x = 1$ B) $y = 1$ C) $y = -2$ D) $x = -2$

137) Slope undefined; containing the point $\left(-\frac{3}{4}, 7\right)$ 137) _____

A) $x = 7$ B) $y = -\frac{3}{4}$ C) $x = -\frac{3}{4}$ D) $y = 7$

138) Vertical line; containing the point $(2.1, 2.6)$ 138) _____

A) $x = 2.1$ B) $x = 4.7$ C) $x = 0$ D) $x = 2.6$

Find the slope-intercept form of the equation of the line with the given properties.

139) Horizontal; containing the point $(9, -10)$ 139) _____

A) $y = 9$ B) $x = -10$ C) $x = 9$ D) $y = -10$

140) Slope = 0; containing the point $(-6, -5)$ 140) _____

A) $y = -6$ B) $x = -6$ C) $x = -5$ D) $y = -5$

141) Horizontal; containing the point $\left(-\frac{1}{9}, 7\right)$ 141) _____

A) $y = 0$ B) $y = -\frac{1}{9}$ C) $y = -7$ D) $y = 7$

142) Horizontal; containing the point $(5.2, -4.9)$ 142) _____

A) $y = 5.2$ B) $y = 0.3$ C) $y = -4.9$ D) $y = 0$

Find the slope of the line and sketch its graph.

143) $y - 5 = 0$

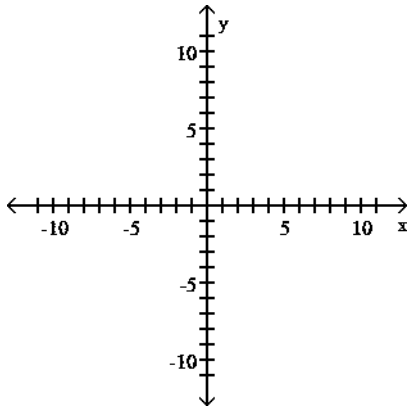

143) _____

A) slope = 0

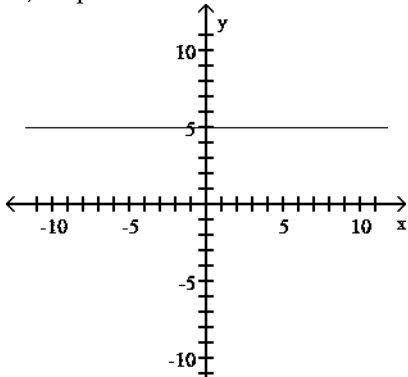

B) slope is undefined

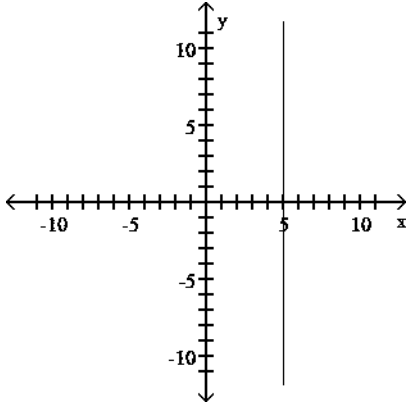

C) slope = $\frac{1}{5}$

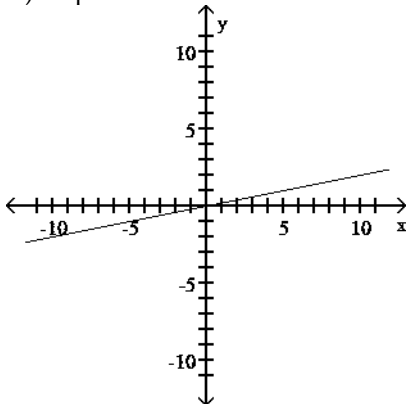

D) slope = 5

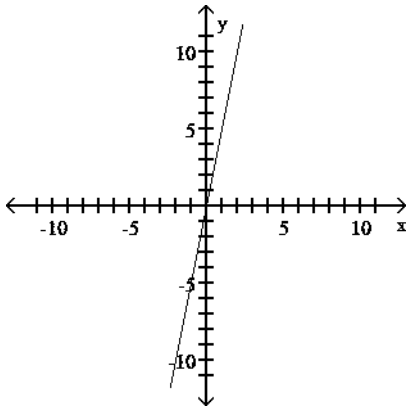

Find the equation of the line in slope-intercept form.

144)

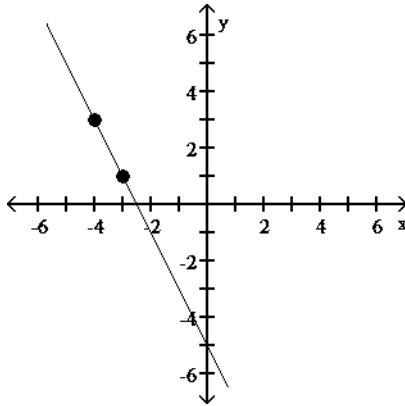

144) _____

- A) $y = -2x + 5$ B) $y = -2x - 5$ C) $y = -2x + 2$ D) $y = -\frac{1}{2}x - \frac{7}{5}$

Find an equation for the line, in the indicated form, with the given properties.

145) Containing the points (4, 1) and (2, -4); slope-intercept form 145) _____

- A) $y = mx - 9$ B) $y - 1 = \frac{5}{2}(x - 4)$ C) $y = -\frac{5}{2}x - 9$ D) $y = \frac{5}{2}x - 9$

146) Containing the points (1, -8) and (-4, 3); general form 146) _____

- A) $-9x + 7y = 15$ B) $9x - 7y = 15$ C) $-11x + 5y = -29$ D) $11x + 5y = -29$

147) Containing the points (8, 0) and (0, -12); general form 147) _____

- A) $y = -\frac{3}{2}x + 8$ B) $y = -\frac{3}{2}x - 12$ C) $12x - 8y = 96$ D) $12x + 8y = 96$

148) Containing the points (6, 4) and (2, 9); general form 148) _____

- A) $-2x + 7y = -67$ B) $2x - 7y = -67$ C) $-5x + 4y = 46$ D) $5x + 4y = 46$

149) Containing the points (-2, 6) and (0, 9); general form 149) _____

- A) $8x + 9y = -81$ B) $3x - 2y = -18$ C) $-3x - 2y = -18$ D) $-8x - 9y = -81$

150) Containing the points (-8, 0) and (4, -5); general form 150) _____

- A) $-8x + 9y = -13$ B) $8x - 9y = -13$ C) $-5x - 12y = 40$ D) $5x - 12y = 40$

151) Containing the points (6, -5) and (-3, 3); general form 151) _____

- A) $-8x + 9y = 3$ B) $11x - 6y = 15$ C) $8x + 9y = 3$ D) $-11x + 6y = 15$

Solve.

152) The relationship between Celsius ($^{\circ}\text{C}$) and Fahrenheit ($^{\circ}\text{F}$) degrees of measuring temperature is linear. Find an equation relating $^{\circ}\text{C}$ and $^{\circ}\text{F}$ if 10°C corresponds to 50°F and 30°C corresponds to 86°F . Use the equation to find the Celsius measure of 20°F . 152) _____

- A) $C = \frac{5}{9}F + \frac{160}{9}$; $\frac{260}{9}^{\circ}\text{C}$ B) $C = \frac{5}{9}F - \frac{160}{9}$; $-\frac{20}{3}^{\circ}\text{C}$
 C) $C = \frac{5}{9}F - 10$; $\frac{10}{9}^{\circ}\text{C}$ D) $C = \frac{9}{5}F - 80$; -44°C

153) A school has just purchased new computer equipment for \$19,000.00. The graph shows the depreciation of the equipment over 5 years. The point (0, 19,000) represents the purchase price and the point (5, 0) represents when the equipment will be replaced. Write a linear equation in slope-intercept form that relates the value of the equipment, y, to years after purchase x. Use the equation to predict the value of the equipment after 1 years.

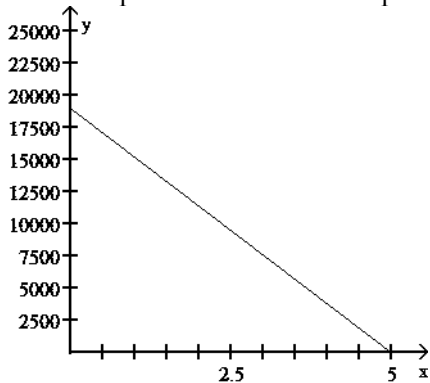

153) _____

- A) $y = -3800x + 19,000$;
 value after 1 years is \$15,200.00; B) $y = 3800x - 19,000$;
 value after 1 years is \$15,200.00
 C) $y = 19,000x + 5$;
 value after 1 years is \$15,200.00 D) $y = -19,000x + 19,000$;
 value after 1 years is \$0.00

154) The average value of a certain type of automobile was \$13,980 in 1995 and depreciated to \$4500 in 2000. Let y be the average value of the automobile in the year x, where x = 0 represents 1995. Write a linear equation that relates the average value of the automobile, y, to the year x. 154) _____

- A) $y = -1896x - 4980$ B) $y = -\frac{1}{1896}x - 4500$
 C) $y = -1896x + 13,980$ D) $y = -1896x + 4500$

155) An investment is worth \$3765 in 1994. By 1997 it has grown to \$4338. Let y be the value of the investment in the year x, where x = 0 represents 1994. Write a linear equation that relates the value of the investment, y, to the year x. 155) _____

- A) $y = -191x + 3765$ B) $y = -191x + 4911$

C) $y = 191x + 3765$ D) $y = \frac{1}{191}x + 3765$

156) A faucet is used to add water to a large bottle that already contained some water. After it has been filling for 3 seconds, the gauge on the bottle indicates that it contains 11 ounces of water. After it has been filling for 11 seconds, the gauge indicates the bottle contains 27 ounces of water. Let y be the amount of water in the bottle x seconds after the faucet was turned on. Write a linear equation that relates the amount of water in the bottle, y , to the time x . 156)

A) $y = \frac{1}{2}x + \frac{19}{2}$ B) $y = 2x + 5$ C) $y = -2x + 17$ D) $y = 2x + 16$

157) When making a telephone call using a calling card, a call lasting 5 minutes cost \$0.95. A call lasting 14 minutes cost \$1.85. Let y be the cost of making a call lasting x minutes using a calling card. Write a linear equation that relates the cost of a making a call, y , to the time x . 157) _____

A) $y = -0.1x + 1.45$ B) $y = 0.1x - 12.15$ C) $y = 10x - \frac{981}{20}$ D) $y = 0.1x + 0.45$

158) A vendor has learned that, by pricing hot dogs at \$1.25, sales will reach 107 hot dogs per day. Raising the price to \$2.00 will cause the sales to fall to 68 hot dogs per day. Let y be the number of hot dogs the vendor sells at x dollars each. Write a linear equation that relates the number of hot dogs sold per day, y , to the price x . 158) _____

A) $y = -52x - 172$ B) $y = -52x + 172$
 C) $y = -\frac{1}{52}x + \frac{22251}{208}$ D) $y = 52x + 42$

159) A vendor has learned that, by pricing caramel apples at \$1.50, sales will reach 112 caramel apples per day. Raising the price to \$2.25 will cause the sales to fall to 73 caramel apples per day. Let y be the number of caramel apples the vendor sells at x dollars each. Write a linear equation that relates the number of caramel apples sold per day to the price x . 159) _____

A) $y = 52x + 34$ B) $y = -52x + 190$
 C) $y = -\frac{1}{52}x + \frac{11645}{104}$ D) $y = -52x - 190$

Find the slope-intercept form of the equation of the line with the given properties.

160) Slope = 5; containing the point (-2, -5) 160) _____

A) $y = 5x - 5$ B) $y = -5x + 5$ C) $y = -5x - 5$ D) $y = 5x + 5$

161) Slope = 0; containing the point (-6, -3) 161) _____

A) $x = -3$ B) $x = -6$ C) $y = -3$ D) $y = -6$

162) Slope = 2; y-intercept = -8 162) _____

A) $y = 2x + 8$ B) $y = 2x - 8$ C) $y = -8x - 2$ D) $y = -8x + 2$

163) x-intercept = 3; y-intercept = 5 163) _____

A) $y = -\frac{3}{5}x + 3$ B) $y = \frac{5}{3}x + 5$ C) $y = -\frac{5}{3}x + 3$ D) $y = -\frac{5}{3}x + 5$

Write the equation in slope-intercept form.

164) $11x + 2y = 17$ 164) _____
A) $y = \frac{11}{2}x - \frac{17}{2}$ B) $y = -\frac{11}{2}x + \frac{17}{2}$ C) $y = 11x - 17$ D) $y = \frac{11}{2}x + \frac{17}{2}$

165) $6x + 7y = 3$ 165) _____
A) $y = 6x + 10$ B) $y = \frac{10}{7}x + \frac{3}{7}$ C) $y = \frac{7}{6}x - \frac{3}{6}$ D) $y = \frac{6}{7}x + \frac{3}{7}$

166) $3x - 5y = 9$ 166) _____
A) $y = \frac{3}{5}x + \frac{9}{5}$ B) $y = \frac{5}{3}x + \frac{9}{3}$ C) $y = \frac{3}{5}x - \frac{9}{5}$ D) $y = 3x - 9$

167) $x = 7y + 6$ 167) _____
A) $y = 7x - 6$ B) $y = x - \frac{6}{7}$ C) $y = \frac{1}{7}x - 6$ D) $y = \frac{1}{7}x - \frac{6}{7}$

Solve.

168) A truck rental company rents a moving truck one day by charging \$31 plus \$0.09 per mile. Write a linear equation that relates the cost C , in dollars, of renting the truck to the number x of miles driven. What is the cost of renting the truck if the truck is driven 210 miles? 168) _____

A) $C = 31x + 0.09$; \$6510.09 B) $C = 0.09x + 31$; \$49.90
C) $C = 0.09x - 31$; \$12.10 D) $C = 0.09x + 31$; \$32.89

169) Each week a soft drink machine sells x cans of soda for \$0.75/soda. The cost to the owner of the soda machine for each soda is \$0.10. The weekly fixed cost for maintaining the soda machine is \$25/week. Write an equation that relates the weekly profit, P , in dollars to the number of cans sold each week. Then use the equation to find the weekly profit when 92 cans of soda are sold in a week. 169) _____

A) $P = 0.75x - 25$; \$44.00 B) $P = 0.65x + 25$; \$84.80
C) $P = 0.75x + 25$; \$94.00 D) $P = 0.65x - 25$; \$34.80

170) Each day the commuter train transports x passengers to or from the city at \$1.75/passenger. The daily fixed cost for running the train is \$1200. Write an equation that relates the daily profit, P , in dollars to the number of passengers each day. Then use the equation to find the daily profit when the train has 920 passengers in a day. 170) _____

A) $P = 1.75x + 1200$; \$2810 B) $P = 1.75x$; \$1610
C) $P = 1200 - 1.75x$; \$410 D) $P = 1.75x - 1200$; \$410

171) Each month a beauty salon gives x manicures for \$12.00/manicure. The cost to the owner of the beauty salon for each manicure is \$7.35. The monthly fixed cost to maintain a manicure station is \$120.00. Write an equation that relates the monthly profit, in dollars, to the number of manicures given each month. Then use the equation to find the monthly profit when 200 manicures are given in a month. 171) _____

A) $P = 7.35x - 120$; \$1350 B) $P = 4.65x$; \$930
C) $P = 4.65x - 120$; \$810 D) $P = 12x - 120$; \$2280

172) Each month a gas station sells x gallons of gas at \$1.92/gallon. The cost to the owner of the gas station for each gallon of gas is \$1.32. The monthly fixed cost for running the gas station is \$37,000. Write an equation that relates the monthly profit, in dollars, to the number of gallons of gasoline sold. Then use the equation to find the monthly profit when 75,000

gallons of gas are sold in a month. 172) _____

- A) $P = 1.32x - 37,000$; \$62,000 B) $P = 1.92x - 37,000$; \$107,000
C) $P = 0.60x - 37,000$; \$8000 D) $P = 0.60x + 37,000$; \$82,000

Find the slope and y-intercept of the line.

173) $y = \frac{7}{4}x - 4$ 173) _____

- A) slope = -4; y-intercept = $\frac{7}{4}$ B) slope = $-\frac{7}{4}$; y-intercept = 4
C) slope = $\frac{4}{7}$; y-intercept = 4 D) slope = $\frac{7}{4}$; y-intercept = -4

174) $x + y = -6$ 174) _____

- A) slope = 0; y-intercept = -6 B) slope = 1; y-intercept = -6
C) slope = -1; y-intercept = 6 D) slope = -1; y-intercept = -6

175) $5x + y = 8$ 175) _____

- A) slope = $-\frac{1}{5}$; y-intercept = $\frac{8}{5}$ B) slope = $\frac{5}{8}$; y-intercept = $\frac{1}{8}$
C) slope = 5; y-intercept = 8 D) slope = -5; y-intercept = 8

176) $-6x + 7y = 10$ 176) _____

- A) slope = $\frac{12}{7}$; y-intercept = $\frac{10}{7}$ B) slope = $\frac{7}{6}$; y-intercept = $-\frac{10}{6}$
C) slope = 6; y-intercept = 12 D) slope = $\frac{6}{7}$; y-intercept = $\frac{10}{7}$

177) $2x + 9y = 19$ 177) _____

- A) slope = $-\frac{2}{9}$; y-intercept = $\frac{19}{9}$ B) slope = $\frac{2}{9}$; y-intercept = $\frac{19}{9}$
C) slope = $\frac{2}{9}$; y-intercept = $-\frac{19}{9}$ D) slope = 2; y-intercept = 19

178) $7x - 6y = 5$ 178) _____

- A) slope = $\frac{6}{7}$; y-intercept = $\frac{5}{7}$ B) slope = 7; y-intercept = 5
C) slope = $\frac{7}{6}$; y-intercept = $-\frac{5}{6}$ D) slope = $\frac{7}{6}$; y-intercept = $\frac{5}{6}$

179) $12x - 3y = 36$ 179) _____

- A) slope = $\frac{1}{4}$; y-intercept = 3 B) slope = 4; y-intercept = -12
C) slope = -4; y-intercept = 12 D) slope = 12; y-intercept = 36

180) $x + 11y = 1$ 180) _____

- A) slope = 1; y-intercept = 1 B) slope = -11; y-intercept = 11

C) slope = $\frac{1}{11}$; y-intercept = $\frac{1}{11}$ D) slope = $-\frac{1}{11}$; y-intercept = $\frac{1}{11}$

181) $-x + 7y = 84$ 181) _____

A) slope = $-\frac{1}{7}$; y-intercept = 12 B) slope = $\frac{1}{7}$; y-intercept = 12
 C) slope = -1; y-intercept = 84 D) slope = 7; y-intercept = -84

182) $y = -5$ 182) _____

A) slope = 1; y-intercept = -5 B) slope = 0; no y-intercept
 C) slope = -5; y-intercept = 0 D) slope = 0; y-intercept = -5

183) $x = -1$ 183) _____

A) slope undefined; y-intercept = -1 B) slope = -1; y-intercept = 0
 C) slope = 0; y-intercept = -1 D) slope undefined; no y-intercept

184) $y = 4x$ 184) _____

A) slope = 0; y-intercept = 4 B) slope = -4; y-intercept = 0
 C) slope = $\frac{1}{4}$; y-intercept = 0 D) slope = 4; y-intercept = 0

Find the general form of the equation for the line with the given properties.

185) Slope = $\frac{3}{5}$; y-intercept = $\frac{4}{5}$ 185) _____

A) $y = \frac{3}{5}x - \frac{4}{5}$ B) $3x - 5y = -4$ C) $3x + 5y = -4$
 D) $y = \frac{3}{5}x + \frac{4}{5}$

186) Slope = $-\frac{3}{5}$; containing the point (5, 2) 186) _____

A) $5x + 3y = -25$ B) $3x + 5y = 25$ C) $3x - 5y = 25$ D) $3x + 5y = -25$

187) Slope = $-\frac{5}{9}$; containing the point (0, 3) 187) _____

A) $5x + 9y = -27$ B) $5x - 9y = 27$ C) $5x + 9y = 27$ D) $9x + 5y = -27$

188) Slope = $\frac{2}{9}$; containing (0, 2) 188) _____

A) $-2x + 9y = 18$ B) $-2x + 9y = -18$ C) $9x - 2y = -18$ D) $-2x - 9y = 18$

Find the slope of the line and sketch its graph.

189) $3x + 4y = 25$

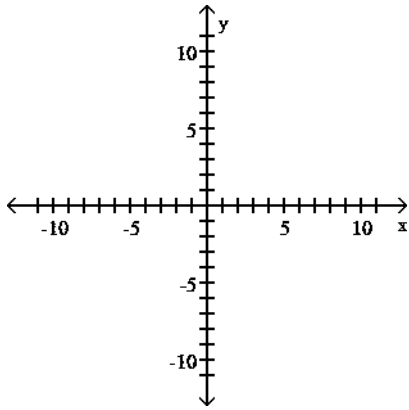

189) _____

A) slope = - $\frac{4}{3}$

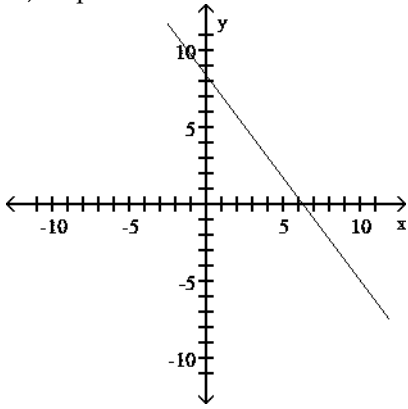

B) slope = $\frac{4}{3}$

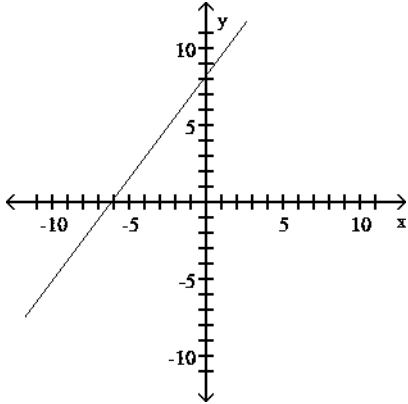

C) slope = - $\frac{3}{4}$

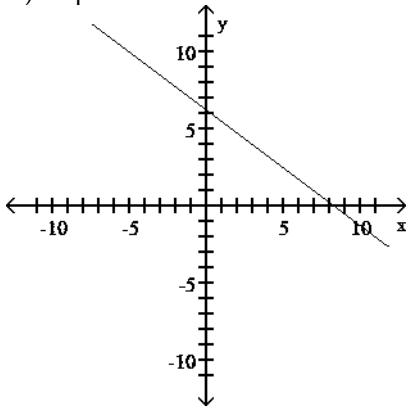

D) slope = $\frac{3}{4}$

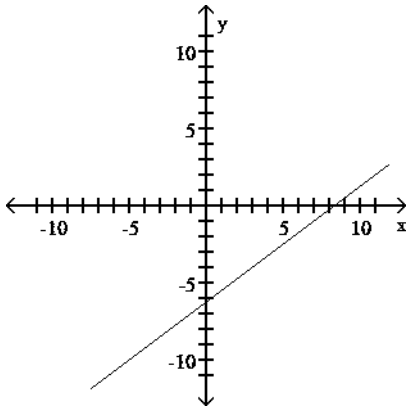

190) $4x - 5y = 2$

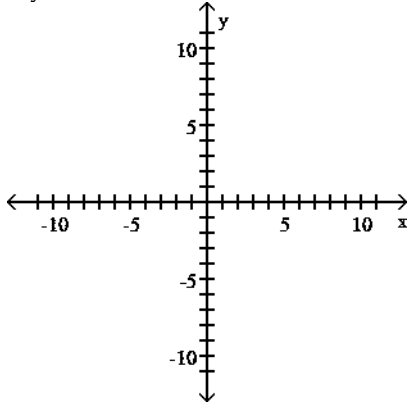

190) _____

A) slope = $-\frac{5}{4}$

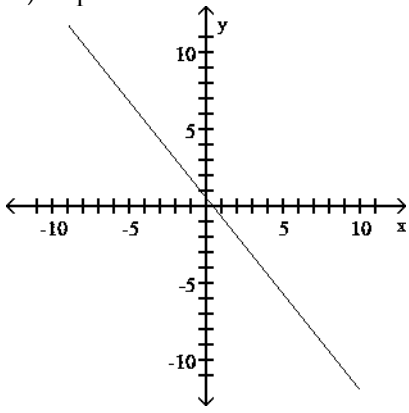

B) slope = $\frac{5}{4}$

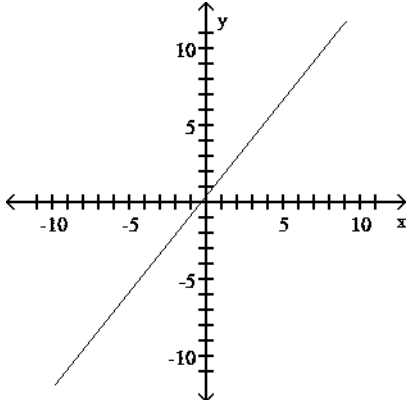

C) slope = $-\frac{4}{5}$

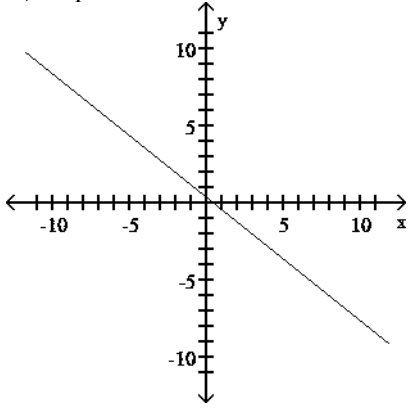

D) slope = $\frac{4}{5}$

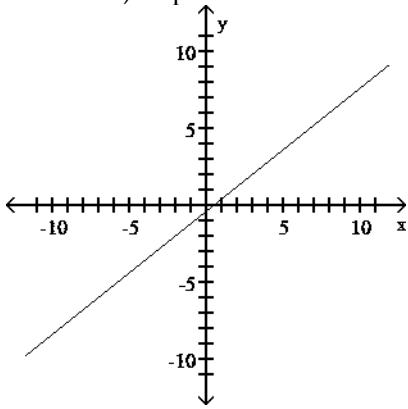

Solve the problem.

191) Find an equation in general form for the line graphed on a graphing utility.

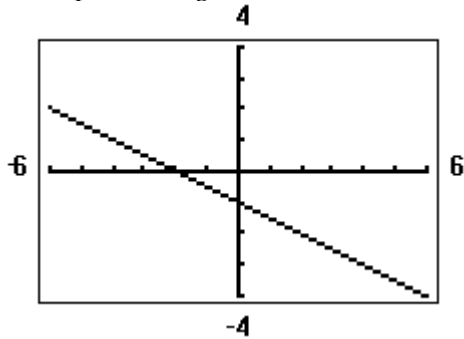

191) _____

- A) $y = -2x - 1$ B) $y = -\frac{1}{2}x - 1$ C) $2x + y = -1$ D) $x + 2y = -2$

Find an equation for the line with the given properties.

192) The solid line L contains the point (2, 1) and is parallel to the dotted line whose equation is $y = 2x$. Give the equation for the line L in slope-intercept form.

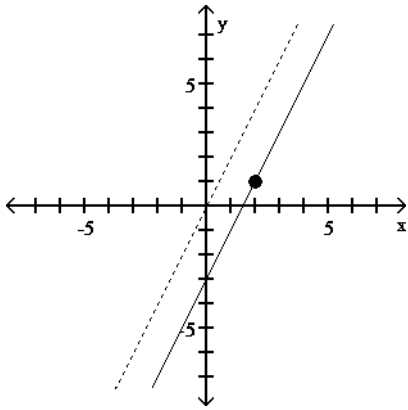

192) _____

- A) $y - 1 = 2(x - 2)$ B) $y = 2x + b$ C) $y = 2x - 1$ D) $y = 2x - 3$

193) Parallel to the line $y = -4x$; containing the point $(2, 3)$ 193) _____

- A) $y = -4x - 11$ B) $y - 3 = -4x - 2$ C) $y = -4x + 11$ D) $y = -4x$

194) Parallel to the line $x + 5y = 3$; containing the point $(0, 0)$ 194) _____

- A) $y = \frac{1}{5}x$ B) $y = \frac{2}{5}$ C) $y = -\frac{1}{5}x + 3$ D) $y = -\frac{1}{5}x$

195) Parallel to the line $-2x - y = 4$; containing the point $(0, 0)$ 195) _____

- A) $y = \frac{1}{2}x$ B) $y = -2x$ C) $y = -\frac{1}{2}x$ D) $y = \frac{1}{2}x + 4$

196) Parallel to the line $y = -6$; containing the point $(8, 2)$ 196) _____

- A) $y = 2$ B) $y = 8$ C) $y = -6$ D) $y = -2$

197) Parallel to the line $x = -6$; containing the point $(4, 3)$ 197) _____

- A) $x = 3$ B) $x = 4$ C) $y = 3$ D) $y = -6$

198) Parallel to the line $2x + 7y = 35$; containing the point $(7, 12)$ 198) _____

- A) $7x + 7y = 35$ B) $2x + 7y = 98$ C) $2x - 7y = 98$ D) $7x + 2y = 12$

199) Parallel to the line $-3x - 5y = -5$; x-intercept = 2 199) _____

- A) $-3x - 5y = -10$ B) $-5x + 3y = 6$ C) $-3x - 5y = -6$ D) $-5x + 3y = -10$

200) The solid line L contains the point $(3, 2)$ and is perpendicular to the dotted line whose equation is $y = 2x$. Give the equation of line L in slope-intercept form.

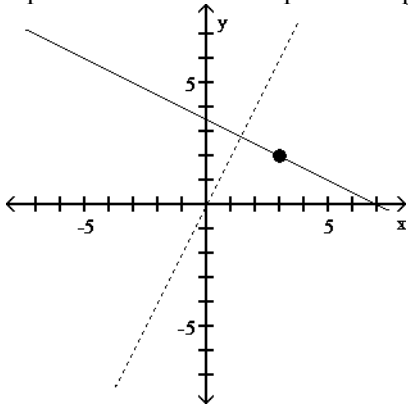

200) _____

A) $y = -\frac{1}{2}x + \frac{7}{2}$ B) $y = \frac{1}{2}x + \frac{7}{2}$

C) $y - 2 = -\frac{1}{2}(x - 3)$ D) $y - 2 = 2(x - 3)$

201) Perpendicular to the line $y = 2x + 1$; containing the point $(-4, -1)$ 201) _____

A) $y = -\frac{1}{2}x - 3$ B) $y = \frac{1}{2}x - 3$ C) $y = 2x - 3$ D) $y = -2x - 3$

202) Perpendicular to the line $y = \frac{1}{7}x + 8$; containing the point $(3, -2)$ 202) _____

A) $y = 7x - 19$ B) $y = -7x - 19$ C) $y = -7x + 19$ D) $y = -\frac{1}{7}x - \frac{19}{7}$

203) Perpendicular to the line $-2x - y = 6$; containing the point $(0, -3)$ 203) _____

A) $y = -\frac{5}{2}$ B) $y = -\frac{1}{2}x - 3$ C) $y = \frac{1}{2}x + 6$ D) $y = \frac{1}{2}x - 3$

204) Perpendicular to the line $x - 7y = 6$; containing the point $(4, 4)$ 204) _____

A) $y = -7x + 32$ B) $y = -7x - 32$ C) $y = 7x - 32$ D) $y = -\frac{1}{7}x - \frac{32}{7}$

205) Perpendicular to the line $y = 8$; containing the point $(2, 3)$ 205) _____

A) $y = 2$ B) $y = 3$ C) $x = 3$ D) $x = 2$

206) Perpendicular to the line $x = -4$; containing the point $(3, 8)$ 206) _____

A) $y = 8$ B) $y = 3$ C) $x = 3$ D) $x = 8$

207) Perpendicular to the line $-9x - 7y = -82$; containing the point $(6, -4)$ 207) _____

A) $7x + 9y = 78$ B) $6x + 7y = -82$ C) $7x - 9y = 78$ D) $-9x + 7 = -9$

208) Perpendicular to the line $-7x + 4y = -15$; containing the point $(5, 6)$ 208) _____

A) $4x - 7y = 62$ B) $4x - 7y = -15$ C) $-7x - 4y = 62$ D) $4x + 7y = 62$

209) Perpendicular to the line $-2x - 3y = -6$; y -intercept = -4 209) _____

A) $-3x + 2y = 12$ B) $-2x - 3y = 12$ C) $-2x - 3y = 8$ D) $-3x + 2y = -8$

Decide whether the pair of lines is parallel, perpendicular, or neither.

210) $3x - 4y = -4$
 $8x + 6y = -11$ 210) _____

A) parallel B) perpendicular C) neither

211) $3x - 4y = 16$
 $8x + 6y = -4$ 211) _____

A) parallel B) perpendicular C) neither

212) $12x + 4y = 16$

$18x + 6y = 26$ 212) _____

- A) parallel B) perpendicular C) neither

Write the standard form of the equation of the circle.

213)

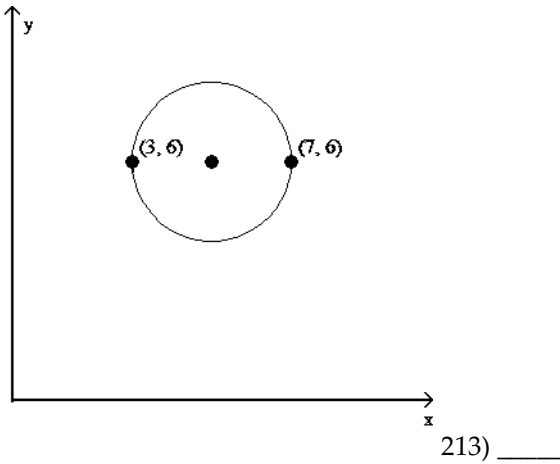

- A) $(x - 5)^2 + (y - 6)^2 = 2$ B) $(x + 5)^2 + (y + 6)^2 = 2$
 C) $(x - 5)^2 + (y - 6)^2 = 4$ D) $(x + 5)^2 + (y + 6)^2 = 4$

214)

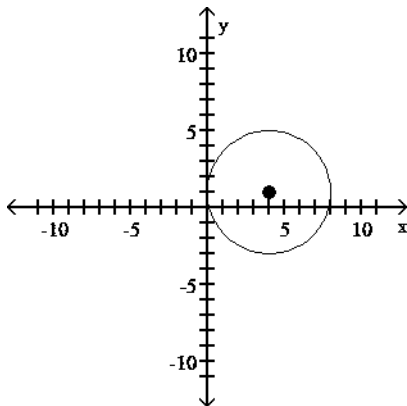

- A) $(x - 1)^2 + (y - 4)^2 = 16$ B) $(x - 4)^2 + (y - 1)^2 = 16$
 C) $(x + 4)^2 + (y + 1)^2 = 16$ D) $(x + 1)^2 + (y + 4)^2 = 16$

Write the standard form of the equation of the circle with radius r and center (h, k).

215) $r = 4$; $(h, k) = (0, 0)$ 215) _____

- A) $(x - 4)^2 + (y - 4)^2 = 16$ B) $x^2 + y^2 = 4$
 C) $x^2 + y^2 = 16$ D) $(x - 4)^2 + (y - 4)^2 = 4$

216) $r = 4$; $(h, k) = (3, -5)$ 216) _____

- A) $(x + 3)^2 + (y - 5)^2 = 16$ B) $(x + 3)^2 + (y - 5)^2 = 4$
 C) $(x - 3)^2 + (y + 5)^2 = 16$ D) $(x - 3)^2 + (y + 5)^2 = 4$

217) $r = 6$; $(h, k) = (6, 0)$ 217) _____

A) $(x - 6)^2 + y^2 = 36$ B) $(x + 6)^2 + y^2 = 36$
 C) $x^2 + (y + 6)^2 = 6$ D) $x^2 + (y - 6)^2 = 6$

218) $r = 6$; $(h, k) = (0, 10)$ 218) _____
 A) $x^2 + (y - 10)^2 = 36$ B) $(x - 10)^2 + y^2 = 36$
 C) $x^2 + (y + 10)^2 = 6$ D) $(x + 10)^2 + y^2 = 36$

219) $r = \sqrt{19}$; $(h, k) = (8, -8)$ 219) _____
 A) $(x - 8)^2 + (y + 8)^2 = 19$ B) $(x + 8)^2 + (y - 8)^2 = 361$
 C) $(x + 8)^2 + (y - 8)^2 = 19$ D) $(x - 8)^2 + (y + 8)^2 = 361$

220) $r = \sqrt{7}$; $(h, k) = (0, -9)$ 220) _____
 A) $x^2 + (y + 9)^2 = 7$ B) $(x - 9)^2 + y^2 = 49$
 C) $(x + 9)^2 + y^2 = 49$ D) $x^2 + (y - 9)^2 = 7$

Solve the problem.

221) Find the equation of a circle in standard form where C(6, -2) and D(-4, 4) are endpoints of a diameter. 221) _____

A) $(x + 1)^2 + (y + 1)^2 = 136$ B) $(x - 1)^2 + (y - 1)^2 = 136$
 C) $(x - 1)^2 + (y - 1)^2 = 34$ D) $(x + 1)^2 + (y + 1)^2 = 34$

222) Find the equation of a circle in standard form with center at the point (-3, 2) and tangent to the line $y = 4$. 222) _____

A) $(x + 3)^2 + (y - 2)^2 = 16$ B) $(x - 3)^2 + (y + 2)^2 = 4$
 C) $(x + 3)^2 + (y - 2)^2 = 4$ D) $(x - 3)^2 + (y + 2)^2 = 16$

223) Find the equation of a circle in standard form that is tangent to the line $x = -3$ at (-3, 5) and also tangent to the line $x = 9$. 223) _____

A) $(x - 3)^2 + (y + 5)^2 = 36$ B) $(x + 3)^2 + (y + 5)^2 = 36$
 C) $(x - 3)^2 + (y - 5)^2 = 36$ D) $(x + 3)^2 + (y - 5)^2 = 36$

Find the center (h, k) and radius r of the circle with the given equation.

224) $x^2 + y^2 = 16$ 224) _____
 A) $(h, k) = (4, 4)$; $r = 4$ B) $(h, k) = (4, 4)$; $r = 16$
 C) $(h, k) = (0, 0)$; $r = 4$ D) $(h, k) = (0, 0)$; $r = 16$

225) $(x - 4)^2 + (y - 2)^2 = 64$ 225) _____
 A) $(h, k) = (4, 2)$; $r = 8$ B) $(h, k) = (2, 4)$; $r = 8$
 C) $(h, k) = (2, 4)$; $r = 64$ D) $(h, k) = (4, 2)$; $r = 64$

226) $(x - 3)^2 + y^2 = 100$ 226) _____
 A) $(h, k) = (0, 3)$; $r = 10$ B) $(h, k) = (3, 0)$; $r = 10$
 C) $(h, k) = (0, 3)$; $r = 100$ D) $(h, k) = (3, 0)$; $r = 100$

227) $x^2 + (y + 2)^2 = 4$ 227) _____
 A) $(h, k) = (0, -2)$; $r = 2$ B) $(h, k) = (0, -2)$; $r = 4$

C) $(h, k) = (-2, 0)$; $r = 4$ D) $(h, k) = (-2, 0)$; $r = 2$

228) $2(x+6)^2 + 2(y+3)^2 = 18$ 228) _____

A) $(h, k) = (6, 3)$; $r = 3$ B) $(h, k) = (-6, -3)$; $r = 3$

C) $(h, k) = (-6, -3)$; $r = 6$ D) $(h, k) = (6, 3)$; $r = 6$

Solve the problem.

229) Find the standard form of the equation of the circle. Assume that the center has integer coordinates and the radius is an integer.

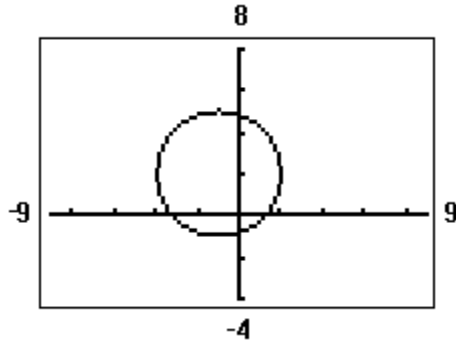

229) _____

A) $x^2 + y^2 + 2x - 4y - 4 = 0$ B) $(x+1)^2 + (y-2)^2 = 9$

C) $x^2 + y^2 - 2x + 4y - 4 = 0$ D) $(x-1)^2 + (y+2)^2 = 9$

Graph the circle with radius r and center (h, k) .

230) $r = 3$; $(h, k) = (0, 0)$

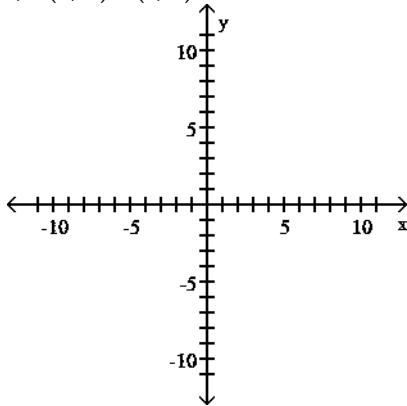

230) _____

A)

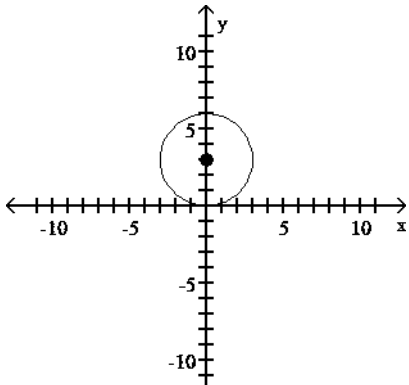

B)

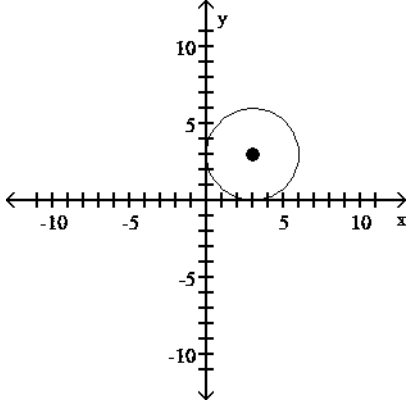

C)

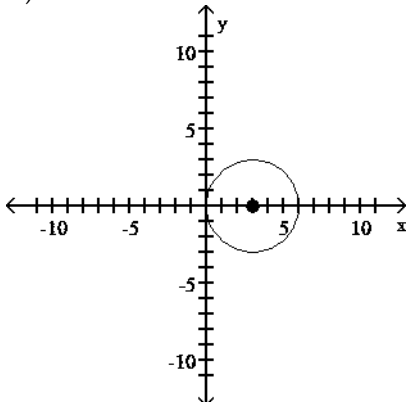

D)

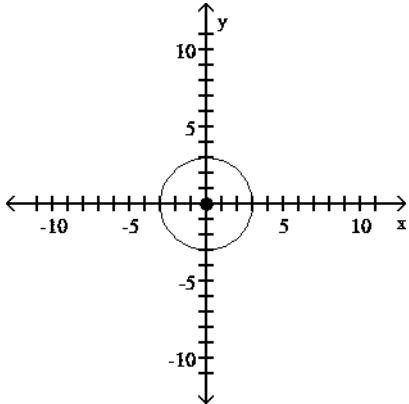

231) $r = 4$; $(h, k) = (0, 2)$

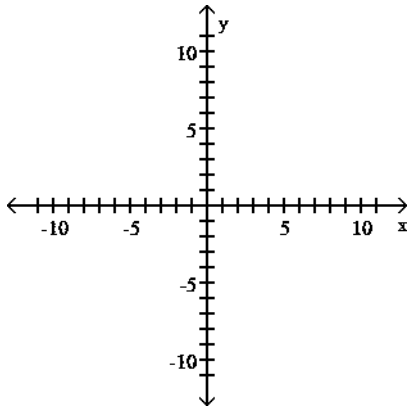

231) _____

A)

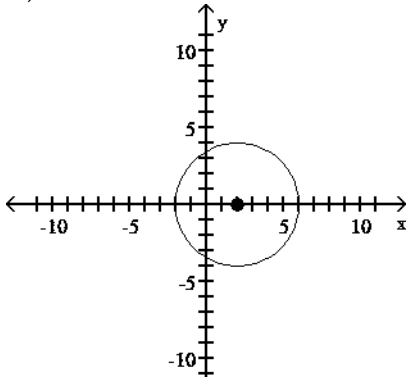

B)

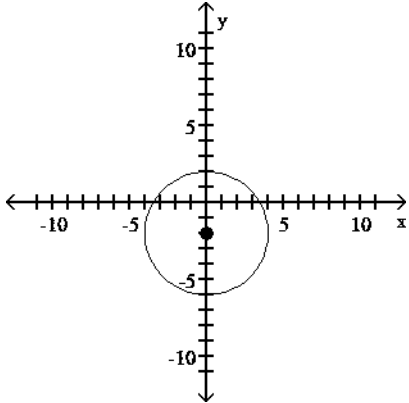

C)

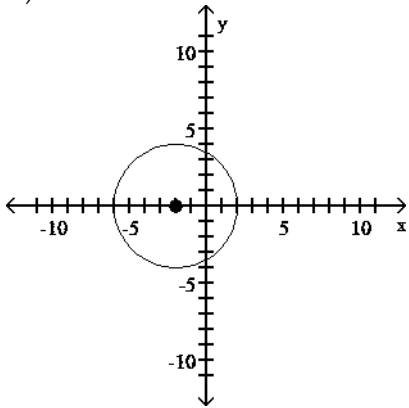

D)

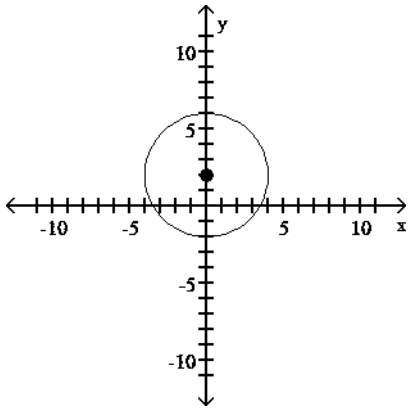

232) $r = 5$; $(h, k) = (1, 0)$

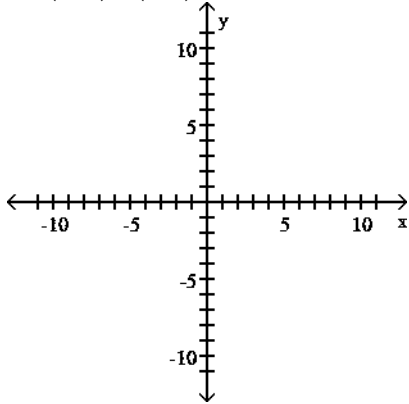

232) _____

A)

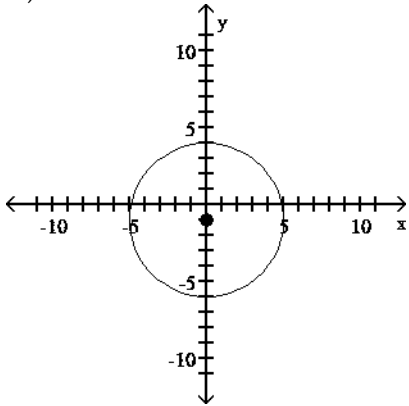

B)

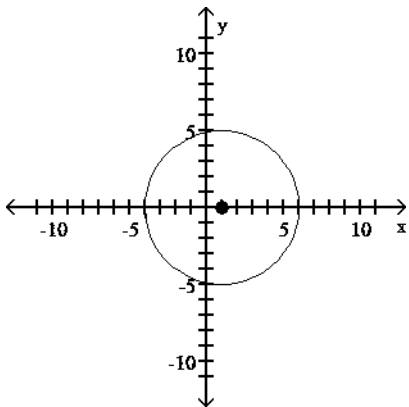

C)

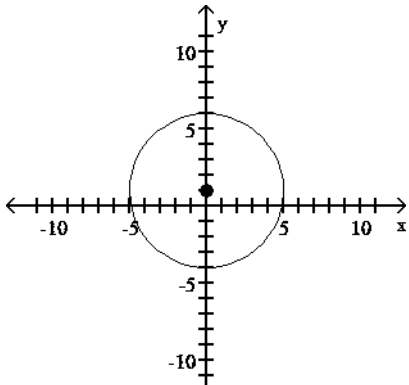

D)

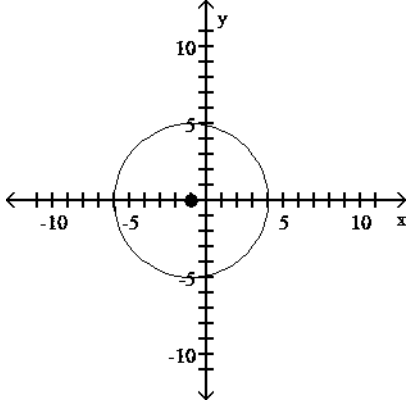

233) $r = 3$; $(h, k) = (-1, 3)$

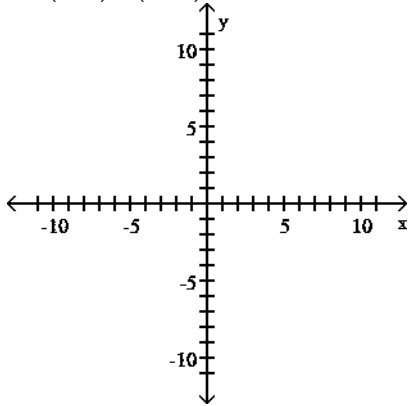

233) _____

A)

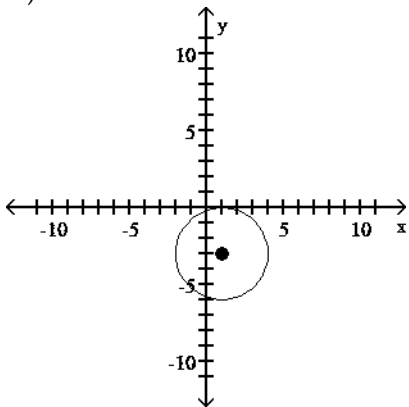

B)

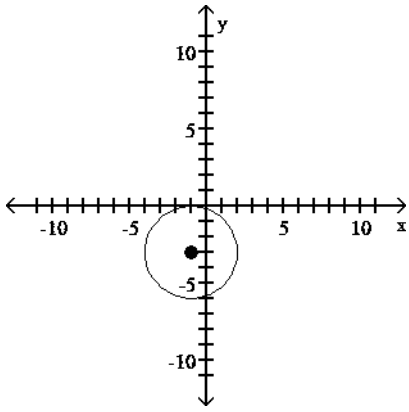

C)

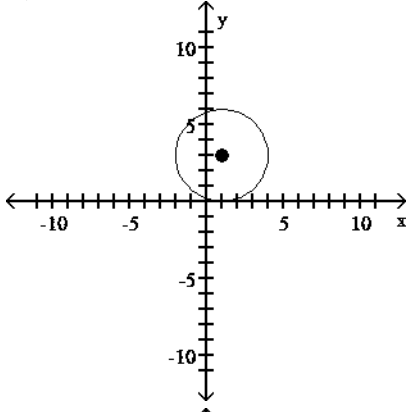

D)

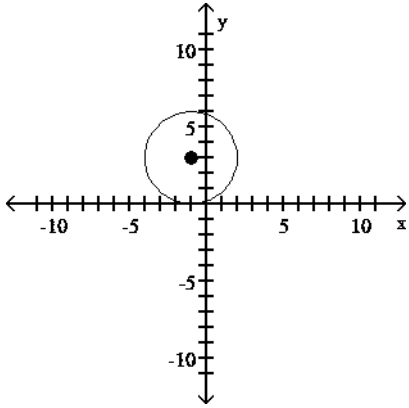

Graph the equation.

234) $x^2 + y^2 = 4$

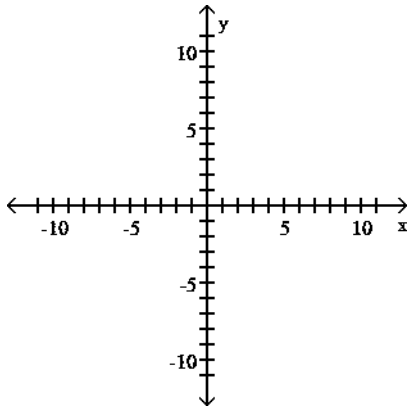

234) _____

A)

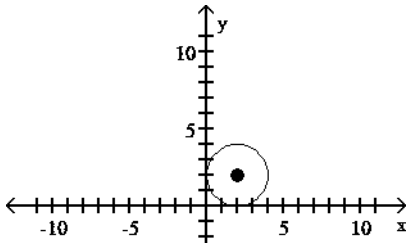

B)

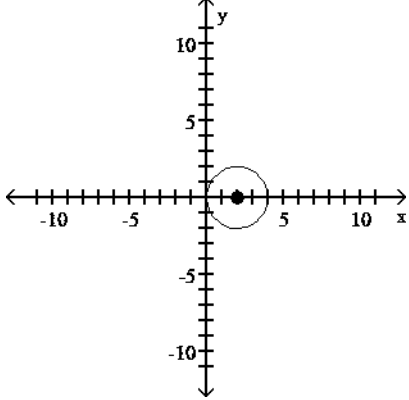

C)

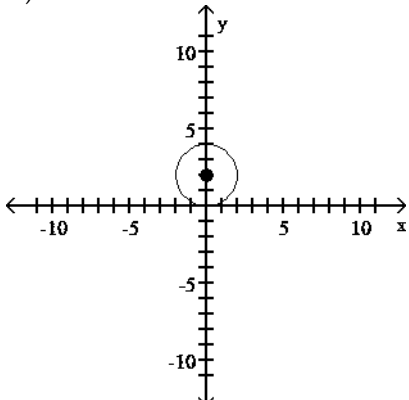

D)

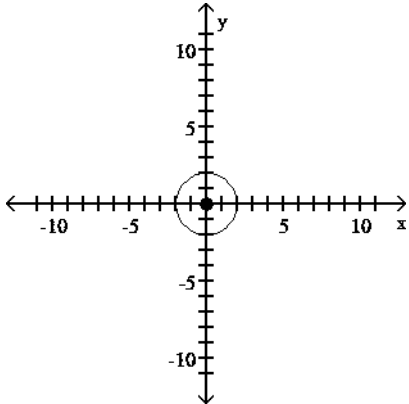

235) $(x-4)^2 + (y+3)^2 = 4$

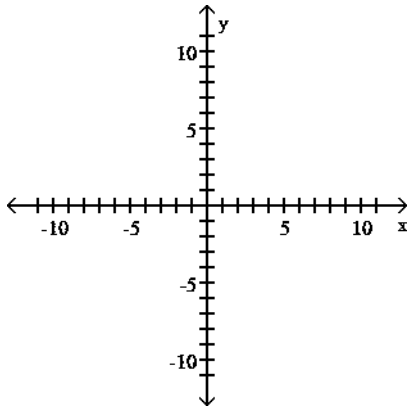

235) _____

A)

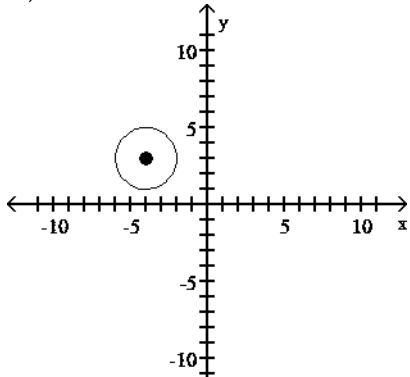

B)

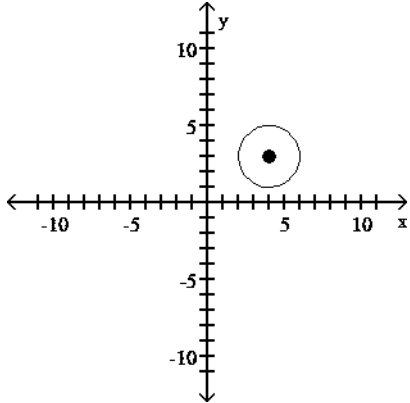

C)

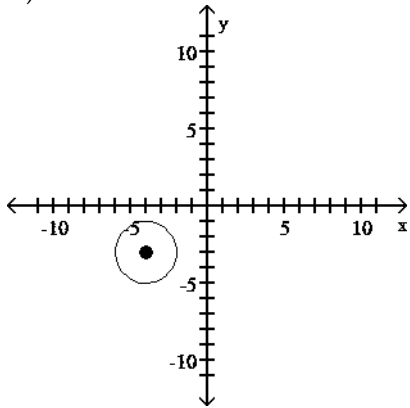

D)

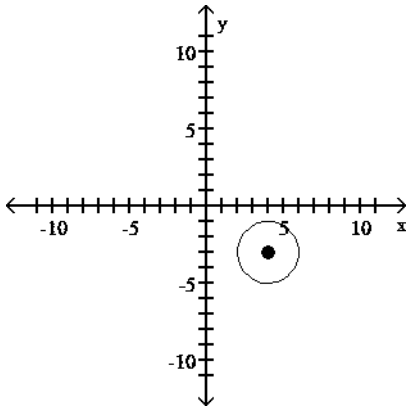

236) $x^2 + (y - 1)^2 = 25$

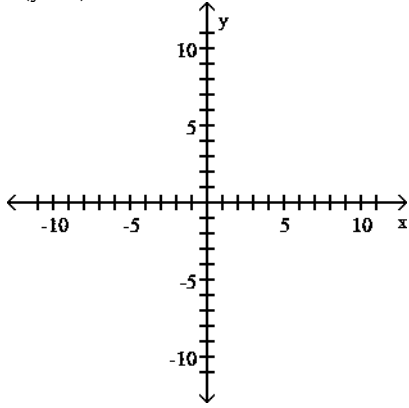

236) _____

A)

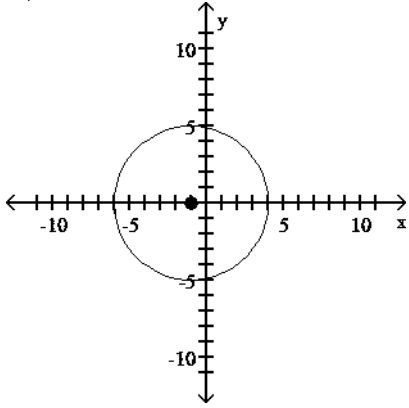

B)

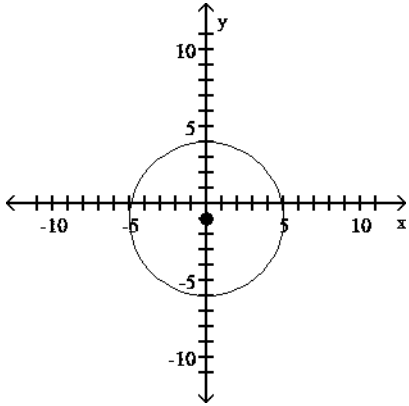

C)

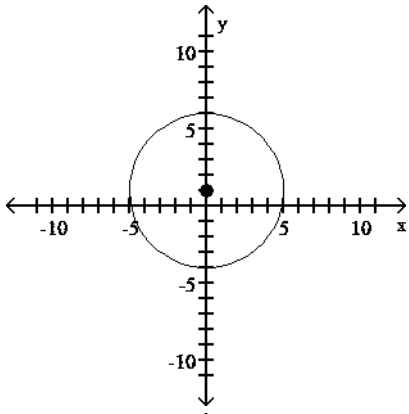

D)

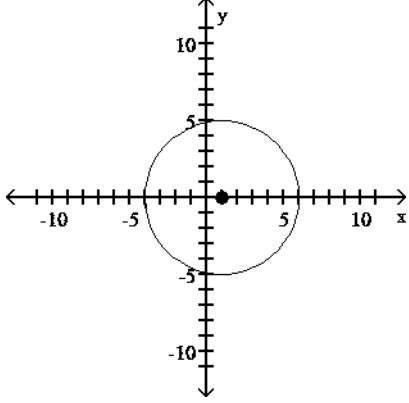

237) $(x - 4)^2 + y^2 = 4$

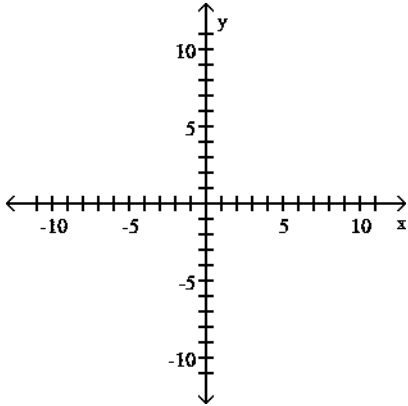

237) _____

A)

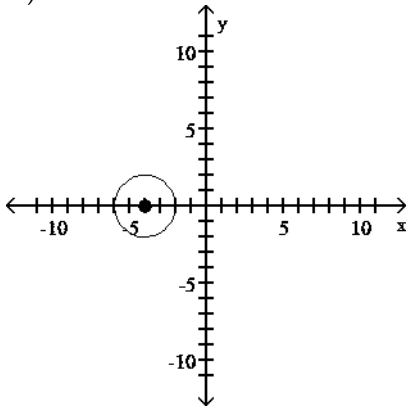

B)

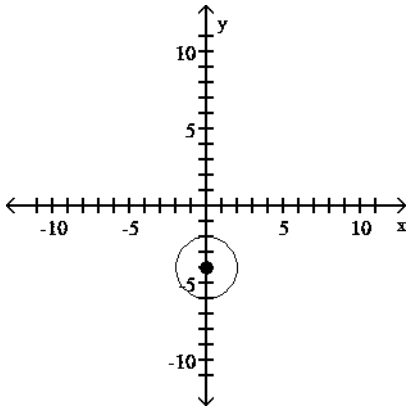

C)

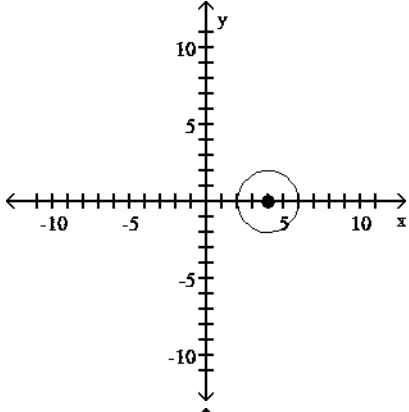

D)

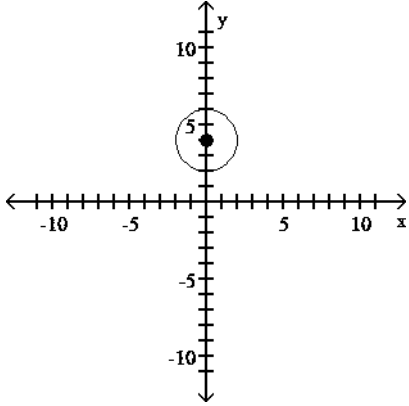

Find the center (h, k) and radius r of the circle. Graph the circle.

238) $x^2 + y^2 - 2x - 12y + 28 = 0$

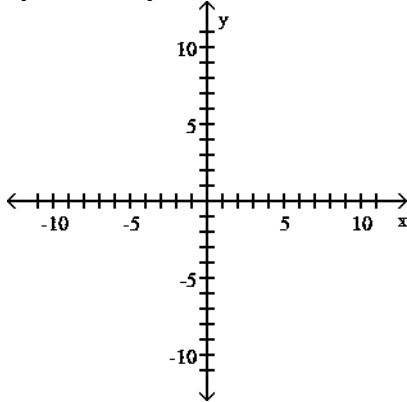

238) _____

A) $(h, k) = (-1, -6); r = 3$

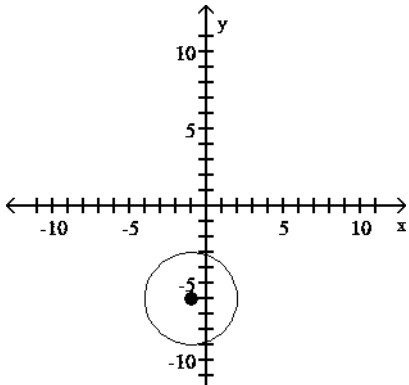

B) $(h, k) = (1, 6); r = 3$

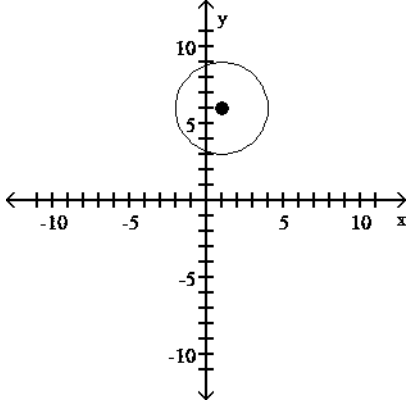

C) $(h, k) = (-1, 6); r = 3$

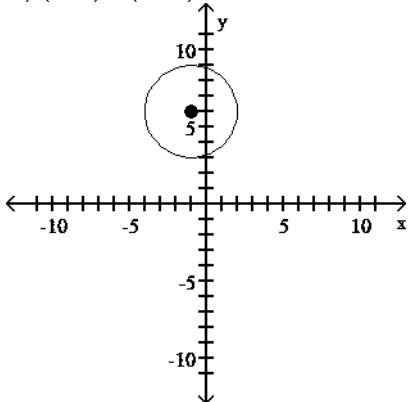

D) $(h, k) = (1, -6); r = 3$

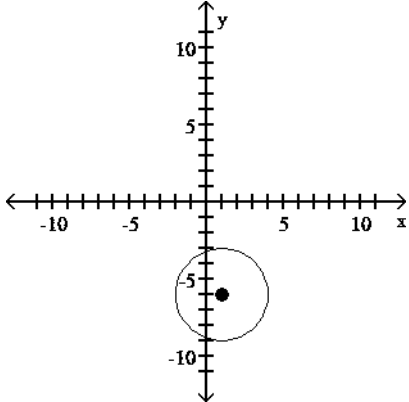

239) $x^2 + y^2 + 6x + 12y + 36 = 0$

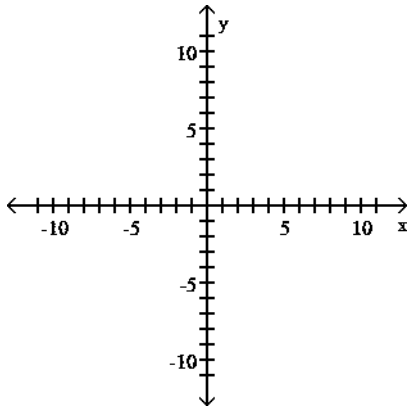

239) _____

A) $(h, k) = (3, 6); r = 3$

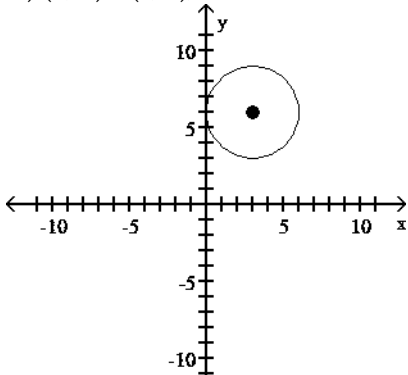

B) $(h, k) = (-3, -6); r = 3$

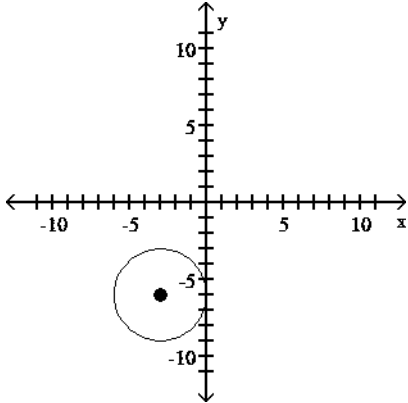

C) $(h, k) = (-3, 6); r = 3$

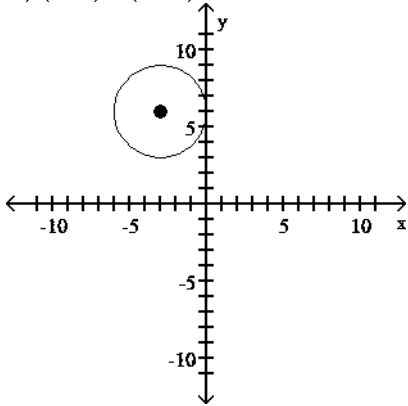

D) $(h, k) = (3, -6); r = 3$

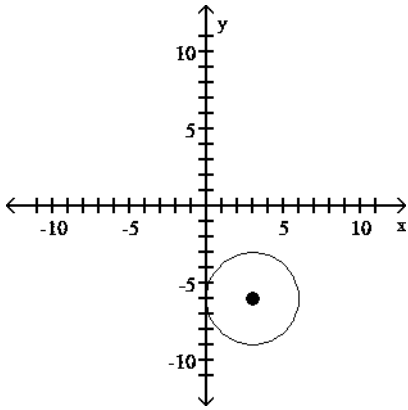

Find the center (h, k) and radius r of the circle with the given equation.

240) $x^2 + 18x + 81 + (y - 6)^2 = 64$ 240) _____

- A) $(h, k) = (9, -6)$; $r = 64$ B) $(h, k) = (6, -9)$; $r = 8$
 C) $(h, k) = (-9, 6)$; $r = 8$ D) $(h, k) = (-6, 9)$; $r = 64$

241) $x^2 - 14x + 49 + y^2 - 6y + 9 = 64$ 241) _____

- A) $(h, k) = (-7, -3)$; $r = 64$ B) $(h, k) = (-3, -7)$; $r = 64$
 C) $(h, k) = (3, 7)$; $r = 8$ D) $(h, k) = (7, 3)$; $r = 8$

242) $x^2 + y^2 + 12x - 18y + 117 = 36$ 242) _____

- A) $(h, k) = (9, -6)$; $r = 6$ B) $(h, k) = (6, -9)$; $r = 36$
 C) $(h, k) = (-6, 9)$; $r = 6$ D) $(h, k) = (-9, 6)$; $r = 36$

243) $x^2 + y^2 - 10x + 8y = 40$ 243) _____

- A) $(h, k) = (-4, 5)$; $r = 9$ B) $(h, k) = (5, -4)$; $r = 9$
 C) $(h, k) = (4, -5)$; $r = 81$ D) $(h, k) = (-5, 4)$; $r = 81$

244) $4x^2 + 4y^2 - 12x + 16y - 5 = 0$ 244) _____

- A) $(h, k) = (-\frac{3}{2}, 2)$; $r = \frac{\sqrt{30}}{2}$ B) $(h, k) = (\frac{3}{2}, -2)$; $r = \frac{\sqrt{30}}{2}$
 C) $(h, k) = (\frac{3}{2}, -2)$; $r = \frac{3\sqrt{5}}{2}$ D) $(h, k) = (-\frac{3}{2}, 2)$; $r = \frac{3\sqrt{5}}{2}$

Find the general form of the equation of the circle.

245) Center at the point $(-4, -3)$; containing the point $(-3, 3)$ 245) _____

- A) $x^2 + y^2 + 6x - 6y - 17 = 0$ B) $x^2 + y^2 - 6x + 6y - 12 = 0$
 C) $x^2 + y^2 + 6x + 8y - 17 = 0$ D) $x^2 + y^2 + 8x + 6y - 12 = 0$

246) Center at the point $(2, -3)$; containing the point $(5, -3)$ 246) _____

- A) $x^2 + y^2 - 4x + 6y + 22 = 0$ B) $x^2 + y^2 - 4x + 6y + 4 = 0$
 C) $x^2 + y^2 + 4x - 6y + 22 = 0$ D) $x^2 + y^2 + 4x - 6y + 4 = 0$

247) Center at the point $(7, 9)$; tangent to x-axis 247) _____

- A) $x^2 + y^2 - 14x - 18y + 211 = 0$ B) $x^2 + y^2 + 14x + 18y + 49 = 0$
 C) $x^2 + y^2 - 14x - 18y + 49 = 0$ D) $x^2 + y^2 - 14x - 18y + 81 = 0$

Solve the problem.

248) If a circle of radius 5 is made to roll along the x-axis, what is the equation for the path of the center of the circle?

248) _____

- A) $x = 5$ B) $y = 10$ C) $y = 5$ D) $y = 0$

249) Earth is represented on a map of the solar system so that its surface is a circle with the equation

$x^2 + y^2 + 10x + 2y - 4070 = 0$. A weather satellite circles 0.8 units above the Earth with the center of its circular orbit at the center of the Earth. Find the general form of the equation for the orbit of the satellite on this map. 249) _____

- A) $x^2 + y^2 + 10x + 2y - 4173.04 = 0$ B) $x^2 + y^2 - 10x - 2y - 4173.04 = 0$
C) $x^2 + y^2 + 10x + 2y - 37.36 = 0$ D) $x^2 + y^2 + 10x + 2y + 25.36 = 0$

250) Find an equation of the line containing the centers of the two circles

$x^2 + y^2 - 8x - 2y + 16 = 0$ and
 $x^2 + y^2 + 2x - 8y + 13 = 0$ 250) _____

- A) $3x - 5y + 17 = 0$ B) $-3x + 5y + 17 = 0$
C) $5x - 3y + 17 = 0$ D) $-3x - 5y + 17 = 0$

251) A wildlife researcher is monitoring a black bear that has a radio telemetry collar with a transmitting range of 15 miles. The researcher is in a research station with her receiver and tracking the bear's movements. If we put the origin of a coordinate system at the research station, what is the equation of all possible locations of the bear where the transmitter would be at its maximum range? 251) _____

- A) $x^2 + y^2 = 225$ B) $x^2 + y^2 = 15$ C) $x^2 + y^2 = 30$ D) $x^2 - y^2 = 15$

252) If a satellite is placed in a circular orbit of 450 kilometers above the Earth, what is the equation of the path of the satellite if the origin is placed at the center of the Earth (the diameter of the Earth is approximately 12,740 kilometers)?

252) _____

- A) $x^2 + y^2 = 173,976,100$ B) $x^2 + y^2 = 40,576,900$
C) $x^2 + y^2 = 202,500$ D) $x^2 + y^2 = 46,512,400$

253) A power outage affected all homes and businesses within a 10 mi radius of the power station. If the power station is located 11 mi north of the center of town, find an equation of the circle consisting of the furthest points from the station affected by the power outage. 253) _____

- A) $x^2 + (y - 11)^2 = 10$ B) $x^2 + y^2 = 100$
C) $x^2 + (y + 11)^2 = 100$ D) $x^2 + (y - 11)^2 = 100$

254) A power outage affected all homes and businesses within a 3 mi radius of the power station. If the power station is located 4 mi west and 4 mi north of the center of town, find an equation of the circle consisting of the furthest points from the station affected by the power outage. 254) _____

- A) $(x + 4)^2 + (y - 4)^2 = 9$ B) $(x - 4)^2 + (y + 4)^2 = 9$
C) $(x - 4)^2 + (y - 4)^2 = 9$ D) $(x + 4)^2 + (y + 4)^2 = 9$

255) A Ferris wheel has a diameter of 280 feet and the bottom of the Ferris wheel is 9 feet above the ground. Find the

equation of the wheel if the origin is placed on the ground directly below the center of the wheel, as illustrated.

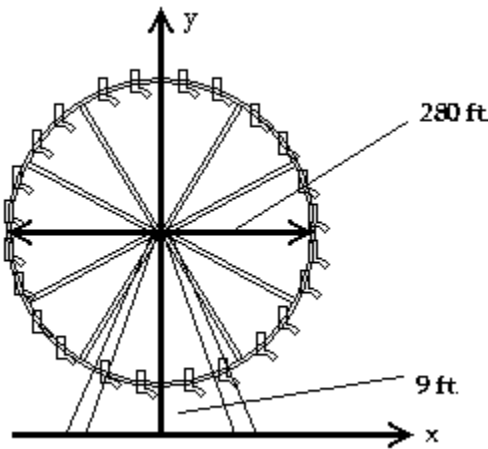

255) _____

- A) $x^2 + (y - 140)^2 = 78,400$ B) $x^2 + (y - 140)^2 = 19,600$
 C) $x^2 + (y - 149)^2 = 19,600$ D) $x^2 + y^2 = 19,600$

Write a general formula to describe the variation.

256) v varies directly with t ; $v = 10$ when $t = 4$ 256) _____

- A) $v = \frac{5}{2}t$ B) $v = \frac{10}{4t}$ C) $v = \frac{2}{5}t$ D) $v = \frac{4}{10t}$

257) A varies directly with t^2 ; $A = 12$ when $t = 2$ 257) _____

- A) $A = 6t^2$ B) $A = 3t^2$ C) $A = \frac{3}{t^2}$ D) $A = \frac{6}{t^2}$

258) z varies directly with the sum of the squares of x and y ; $z = 10$ when $x = 6$ and $y = 8$ 258) _____

- A) $z^2 = x^2 + y^2$ B) $z = \frac{1}{20}(x^2 + y^2)$
 C) $z = \frac{1}{100}(x^2 + y^2)$ D) $z = \frac{1}{10}(x^2 + y^2)$

If y varies directly as x , write a general formula to describe the variation.

259) $y = 6$ when $x = 30$ 259) _____

- A) $y = \frac{1}{6}x$ B) $y = 5x$ C) $y = x + 24$ D) $y = \frac{1}{5}x$

260) $y = 18$ when $x = 4$ 260) _____

- A) $y = x + 14$ B) $y = \frac{9}{2}x$ C) $y = 2x$ D) $y = \frac{2}{9}x$

261) $y = 5$ when $x = \frac{1}{7}$ 261) _____

- A) $y = \frac{1}{35}x$ B) $y = \frac{1}{5}x$ C) $y = x + \frac{34}{7}$ D) $y = 35x$

262) $y = 1.6$ when $x = 0.8$ 262) _____
A) $y = 0.8x$ B) $y = 0.5x$ C) $y = x + 0.8$ D) $y = 2x$

263) $y = 0.4$ when $x = 1.6$ 263) _____
A) $y = 0.4x$ B) $y = x - 1.2$ C) $y = 4x$ D) $y = 0.25x$

Write a general formula to describe the variation.

264) The volume V of a right circular cone varies directly with the square of its base radius r and its height h . The constant of proportionality is $\frac{1}{3}\pi$. 264) _____

A) $V = \frac{1}{3}\pi r^2 h$ B) $V = \frac{1}{3r^2}h$ C) $V = \frac{1}{3}\pi r h$ D) $V = \frac{1}{3}\pi r^2 h^2$

265) The surface area S of a right circular cone varies directly as the radius r times the square root of the sum of the squares of the base radius r and the height h . The constant of proportionality is π . 265) _____

A) $S = \pi r \sqrt{r^2 h^2}$ B) $S = \pi r \sqrt{r^2 + h^2}$ C) $S = \pi \sqrt{r^2 + h^2}$ D) $S = \pi r \sqrt{r^2 h}$

Solve the problem.

266) In simplified form, the period of vibration P for a pendulum varies directly as the square root of its length L . If P is 2 sec. when L is 16 in., what is the period when the length is 4 in.? 266) _____

A) 8 sec B) 4 sec C) 1 sec D) 2 sec

267) The amount of water used to take a shower is directly proportional to the amount of time that the shower is in use. A shower lasting 22 minutes requires 8.8 gallons of water. Find the amount of water used in a shower lasting 4 minutes. 267) _____

A) 10 gal B) 1.6 gal C) 48.4 gal D) 2.2 gal

268) If the resistance in an electrical circuit is held constant, the amount of current flowing through the circuit is directly proportional to the amount of voltage applied to the circuit. When 7 volts are applied to a circuit, 70 milliamperes (mA) of current flow through the circuit. Find the new current if the voltage is increased to 11 volts. 268) _____

A) 110 mA B) 120 mA C) 77 mA D) 99 mA

269) The amount of gas that a helicopter uses is directly proportional to the number of hours spent flying. The helicopter flies for 3 hours and uses 21 gallons of fuel. Find the number of gallons of fuel that the helicopter uses to fly for 5 hours. 269) _____

A) 35 gal B) 15 gal C) 42 gal D) 40 gal

270) The distance that an object falls when it is dropped is directly proportional to the square of the amount of time since it was dropped. An object falls 39.2 meters in 2 seconds. Find the distance the object falls in 5 seconds. 270) _____

A) 98 m B) 245 m C) 49 m D) 10 m

Write a general formula to describe the variation.

271) A varies inversely with x^2 ; $A = 4$ when $x = 2$ 271) _____

A) $A = \frac{8}{x^2}$ B) $A = 1x^2$ C) $A = 8x^2$ D) $A = \frac{16}{x^2}$

Write an equation that expresses the relationship. Use k as the constant of variation.

272) r varies inversely as t. 272) _____
 A) $r = \frac{t}{k}$ B) $kr = t$ C) $r = kt$ D) $r = \frac{k}{t}$

273) w varies inversely as the square of z. 273) _____
 A) $w = \frac{k}{z^2}$ B) $w = \frac{z^2}{k}$ C) $w = \frac{\sqrt{z}}{k}$ D) $w = \frac{k}{\sqrt{z}}$

If y varies inversely as x, write a general formula to describe the variation.

274) $y = 8$ when $x = 6$ 274) _____
 A) $y = \frac{4}{3}x$ B) $y = \frac{x}{48}$ C) $y = \frac{1}{48x}$ D) $y = \frac{48}{x}$

275) $y = 60$ when $x = 7$ 275) _____
 A) $y = \frac{x}{420}$ B) $y = \frac{60}{7}x$ C) $y = \frac{1}{420x}$ D) $y = \frac{420}{x}$

276) $y = 12$ when $x = \frac{1}{4}$ 276) _____
 A) $y = \frac{x}{3}$ B) $y = \frac{1}{3x}$ C) $y = \frac{3}{x}$ D) $y = 48x$

277) $y = \frac{1}{5}$ when $x = 25$ 277) _____
 A) $y = \frac{5}{x}$ B) $y = \frac{1}{5x}$ C) $y = \frac{1}{125}x$ D) $y = \frac{x}{5}$

278) $y = 0.2$ when $x = 0.5$ 278) _____
 A) $y = \frac{0.1}{x}$ B) $y = \frac{10}{x}$ C) $y = 0.4x$ D) $y = 10x$

Solve the problem.

279) x varies inversely as v, and $x = 72$ when $v = 4$. Find x when $v = 32$. 279) _____
 A) $x = 36$ B) $x = 8$ C) $x = 9$ D) $x = 16$

280) x varies inversely as y^2 , and $x = 4$ when $y = 15$. Find x when $y = 5$. 280) _____
 A) $x = 3$ B) $x = 48$ C) $x = 36$ D) $x = 100$

281) When the temperature stays the same, the volume of a gas is inversely proportional to the pressure of the gas. If a balloon is filled with 180 cubic inches of a gas at a pressure of 14 pounds per square inch, find the new pressure of the gas if the volume is decreased to 36 cubic inches. 281) _____

- A) 56 psi B) $\frac{18}{7}$ psi C) 65 psi D) 70 psi

282) The amount of time it takes a swimmer to swim a race is inversely proportional to the average speed of the swimmer. A swimmer finishes a race in 30 seconds with an average speed of 5 feet per second. Find the average speed of the swimmer if it takes 50 seconds to finish the race. 282) _____

- A) 5 ft/sec B) 3 ft/sec C) 4 ft/sec D) 2 ft/sec

283) If the force acting on an object stays the same, then the acceleration of the object is inversely proportional to its mass. If an object with a mass of 35 kilograms accelerates at a rate of 3 meters per second per second (m/sec^2) by a force, find the rate of acceleration of an object with a mass of 7 kilograms that is pulled by the same force. 283) _____

- A) $12 m/sec^2$ B) $15 m/sec^2$ C) $10 m/sec^2$ D) $\frac{3}{5} m/sec^2$

284) If the voltage, V, in an electric circuit is held constant, the current, I, is inversely proportional to the resistance, R. If the current is 240 milliamperes (mA) when the resistance is 2 ohms, find the current when the resistance is 12 ohms. 284) _____

- A) 80 mA B) 1434 mA C) 1440 mA D) 40 mA

285) While traveling at a constant speed in a car, the centrifugal acceleration passengers feel while the car is turning is inversely proportional to the radius of the turn. If the passengers feel an acceleration of 12 feet per second per second (ft/sec^2) when the radius of the turn is 70 feet, find the acceleration the passengers feel when the radius of the turn is 280 feet. 285) _____

- A) $5 ft/sec^2$ B) $4 ft/sec^2$ C) $3 ft/sec^2$ D) $6 ft/sec^2$

Write a general formula to describe the variation.

286) The square of G varies directly with the cube of x and inversely with the square of y; $G=2$ when $x=4$ and $y=3$
286) _____

- A) $G^2 = \frac{9}{16} \frac{x^3}{y^2}$ B) $G^2 = \frac{1}{144} (x^3 + y^2)$
C) $G^2 = \frac{3}{2} \frac{x^3}{y^2}$ D) $G^2 = \frac{256}{9} \frac{y^3}{x^2}$

287) R varies directly with g and inversely with the square of h; $R=3$ when $g=3$ and $h=5$. 287) _____

- A) $R = 5 \frac{g}{h^2}$ B) $R = 5 \frac{h^2}{g}$ C) $R = 25 \frac{g}{h^2}$ D) $R = 25g h^2$

288) z varies jointly as the cube root of x and the square of y; $z=75$ when $x=125$ and $y=3$. 288) _____

- A) $z = \frac{1}{135} \frac{3\sqrt{x}}{y^2}$ B) $z = 135 \frac{3\sqrt{x}}{y^2}$ C) $z = \frac{3}{5} \frac{3\sqrt{xy^2}}{y^2}$ D) $z = \frac{5}{3} \frac{3\sqrt{xy^2}}{y^2}$

289) The centrifugal force F of an object speeding around a circular course varies directly as the product of the object's

mass m and the square of its velocity v and inversely as the radius of the turn r . 289) _____

A) $F = \frac{kmv^2}{r}$ B) $F = \frac{km^2v}{r}$ C) $F = \frac{kmv}{r}$ D) $F = \frac{kmr}{v^2}$

290) The safety load λ of a beam with a rectangular cross section that is supported at each end varies directly as the product of the width W and the square of the depth D and inversely as the length L of the beam between the supports. 290) _____

A) $\lambda = \frac{kWD}{L}$ B) $\lambda = \frac{kL}{WD^2}$ C) $\lambda = \frac{kWD^2}{L}$ D) $\lambda = \frac{k(W+D^2)}{L}$

291) The illumination I produced on a surface by a source of light varies directly as the candlepower c of the source and inversely as the square of the distance d between the source and the surface. 291) _____

A) $I = \frac{kd^2}{c}$ B) $I = kc d^2$ C) $I = \frac{kc}{d^2}$ D) $I = \frac{kc^2}{d^2}$

Solve the problem.

292) The volume V of a given mass of gas varies directly as the temperature T and inversely as the pressure P . A measuring device is calibrated to give $V = 319.2 \text{ in}^3$ when $T = 570^\circ$ and $P = 251 \text{ lb/in}^2$. What is the volume on this device when the temperature is 160° and the pressure is 201 lb/in^2 ? 292) _____

A) $V = 132 \text{ in}^3$ B) $V = 92 \text{ in}^3$ C) $V = 112 \text{ in}^3$ D) $V = 8 \text{ in}^3$

293) The time in hours it takes a satellite to complete an orbit around the earth varies directly as the radius of the orbit (from the center of the earth) and inversely as the orbital velocity. If a satellite completes an orbit 840 miles above the earth in 9 hours at a velocity of $25,000 \text{ mph}$, how long would it take a satellite to complete an orbit if it is at 1600 miles above the earth at a velocity of $24,000 \text{ mph}$? (Use 3960 miles as the radius of the earth.) 293) _____

A) 17.86 hr B) 3.13 hr C) 10.86 hr D) 108.59 hr

294) The pressure of a gas varies jointly as the amount of the gas (measured in moles) and the temperature and inversely as the volume of the gas. If the pressure is 1131 kiloPascals (kPa) when the number of moles is 8, the temperature is 290° Kelvin , and the volume is 960 cc , find the pressure when the number of moles is 6, the temperature is 330° K , and the volume is 720 cc . 294) _____

A) 1248 kPa B) 2652 kPa C) 1287 kPa D) 2574 kPa

295) Body-mass index, or BMI, takes both weight and height into account when assessing whether an individual is underweight or overweight. BMI varies directly as one's weight, in pounds, and inversely as the square of one's height, in inches. In adults, normal values for the BMI are between 20 and 25. A person who weighs 161 pounds and is 67 inches tall has a BMI of 25.21. What is the BMI, to the nearest tenth, for a person who weighs 128 pounds and who is 66 inches tall? 295) _____

A) 20.7 B) 21 C) 20 D) 20.3

296) The amount of paint needed to cover the walls of a room varies jointly as the perimeter of the room and the height of the wall. If a room with a perimeter of 40 feet and 10-foot walls requires 4 quarts of paint, find the amount of paint

needed to cover the walls of a room with a perimeter of 70 feet and 6-foot walls. 296) _____

- A) 8.4 qt B) 420 qt C) 42 qt D) 4.2 qt

297) The power that a resistor must dissipate is jointly proportional to the square of the current flowing through the resistor and the resistance of the resistor. If a resistor needs to dissipate 27 watts of power when 3 amperes of current is flowing through the resistor whose resistance is 3 ohms, find the power that a resistor needs to dissipate when 4 amperes of current are flowing through a resistor whose resistance is 6 ohms. 297) _____

- A) 144 watts B) 72 watts C) 24 watts D) 96 watts

298) While traveling in a car, the centrifugal force a passenger experiences as the car drives in a circle varies jointly as the mass of the passenger and the square of the speed of the car. If a passenger experiences a force of 403.2 newtons (N) when the car is moving at a speed of 80 kilometers per hour and the passenger has a mass of 70 kilograms, find the force a passenger experiences when the car is moving at 20 kilometers per hour and the passenger has a mass of 50 kilograms. 298) _____

- A) 18 N B) 16 N C) 24 N D) 20 N

299) The amount of simple interest earned on an investment over a fixed amount of time is jointly proportional to the principle invested and the interest rate. A principle investment of \$4800.00 with an interest rate of 5% earned \$480.00 in simple interest. Find the amount of simple interest earned if the principle is \$4700.00 and the interest rate is 1%. 299) _____

- A) \$9400.00 B) \$96.00 C) \$94.00 D) \$470.00

300) The voltage across a resistor is jointly proportional to the resistance of the resistor and the current flowing through the resistor. If the voltage across a resistor is 15 volts (V) for a resistor whose resistance is 5 ohms and when the current flowing through the resistor is 3 amperes, find the voltage across a resistor whose resistance is 6 ohms and when the current flowing through the resistor is 4 amperes. 300) _____

- A) 24 V B) 18 V C) 12 V D) 20 V

- 1) A
- 2) B
- 3) C
- 4) D
- 5) C
- 6) B
- 7) C
- 8) D
- 9) B
- 10) D
- 11) A
- 12) D
- 13) B
- 14) D
- 15) D
- 16) B
- 17) D
- 18) C
- 19) B
- 20) C
- 21) A
- 22) D
- 23) C
- 24) D
- 25) B
- 26) A
- 27) D
- 28) C
- 29) B
- 30) D
- 31) A
- 32) A
- 33) B
- 34) B
- 35) D
- 36) B
- 37) C
- 38) C
- 39) A
- 40) B
- 41) C
- 42) C
- 43) B
- 44) C
- 45) D
- 46) A
- 47) A
- 48) B
- 49) C
- 50) B
- 51) A

- 52) D
- 53) A
- 54) B
- 55) C
- 56) B
- 57) B
- 58) D
- 59) B
- 60) D
- 61) D
- 62) B
- 63) D
- 64) C
- 65) D
- 66) B
- 67) A
- 68) D
- 69) D
- 70) C
- 71) A
- 72) D
- 73) A
- 74) D
- 75) A
- 76) A
- 77) D
- 78) B
- 79) D
- 80) A
- 81) A
- 82) B
- 83) B
- 84) A
- 85) D
- 86) B
- 87) D
- 88) C
- 89) B
- 90) D
- 91) B
- 92) B
- 93) B
- 94) C
- 95) D
- 96) D
- 97) E
- 98) C
- 99) C
- 100) B
- 101) D
- 102) D
- 103) E

104) C
105) B
106) B
107) E
108) C
109) E
110) C
111) A
112) A
113) C
114) D
115) A
116) C
117) C
118) C
119) B
120) C
121) D
122) D
123) D
124) D
125) B
126) A
127) D
128) D
129) A
130) D
131) B
132) D
133) B
134) C
135) C
136) A
137) C
138) A
139) D
140) D
141) D
142) C
143) A
144) B
145) D
146) D
147) C
148) D
149) B
150) C
151) C
152) B
153) A
154) C
155) C

156) B
157) D
158) B
159) B
160) D
161) C
162) B
163) D
164) B
165) D
166) C
167) D
168) B
169) D
170) D
171) C
172) C
173) D
174) D
175) D
176) D
177) A
178) C
179) B
180) D
181) B
182) D
183) D
184) D
185) B
186) B
187) C
188) A
189) C
190) D
191) D
192) D
193) C
194) D
195) B
196) A
197) B
198) B
199) C
200) A
201) A
202) C
203) D
204) A
205) D
206) A
207) C

208) D
209) D
210) B
211) B
212) A
213) C
214) B
215) C
216) C
217) A
218) A
219) A
220) A
221) C
222) C
223) C
224) C
225) A
226) B
227) A
228) B
229) B
230) D
231) D
232) B
233) D
234) D
235) D
236) C
237) C
238) B
239) B
240) C
241) D
242) C
243) B
244) B
245) D
246) B
247) C
248) C
249) A
250) D
251) A
252) D
253) D
254) A
255) C
256) A
257) B
258) D
259) D

260) B
261) D
262) D
263) D
264) A
265) B
266) C
267) B
268) A
269) A
270) B
271) D
272) D
273) A
274) D
275) D
276) C
277) A
278) A
279) C
280) C
281) D
282) B
283) B
284) D
285) C
286) A
287) C
288) D
289) A
290) C
291) C
292) C
293) C
294) C
295) A
296) D
297) D
298) A
299) C
300) A